

PHIESTINA

INSTRUCTION MANUAL

Compressor Beverage Refrigerator

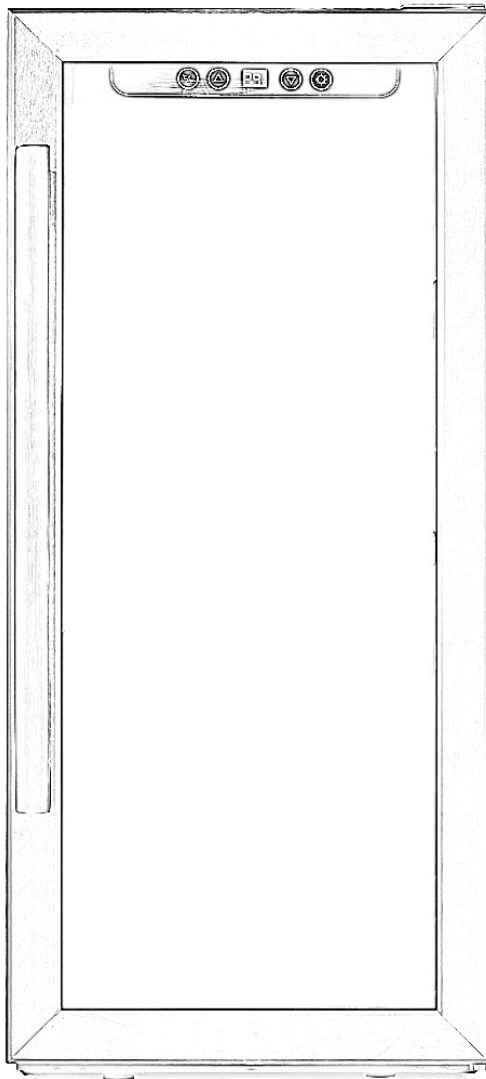

MODEL: PH-CBR100

Please read carefully and follow all safety rules and operating instructions.

- This appliance can't be used by children or persons with reduced physical, sensory or mental capabilities or lack of experience.
- Children shall not play with the appliance. Cleaning and user maintenance shall not be made by children without supervision.
- If the supply cord is damaged, it must be replaced by the manufacturer, its service agent or similarly qualified persons in order to avoid a hazard.
- Keep ventilation openings, in the appliance enclosure or in the built-in structure, clear of obstruction.
- Do not use mechanical devices or other means to accelerate the defrosting process, other than those recommended by the manufacturer.
- Do not damage the refrigerant circuit.
- Do not use electrical appliances inside the wine storage compartments of the appliance, unless they are of the type recommended by the manufacturer.
- Do not store explosive substances such as aerosol cans with a flammable propellant in this appliance
- This appliance is intended to be used in household and similar applications such as kitchen areas in home, offices and other similar environments.

Content

1. Your Beverage Refrigerator.....	4
2. Technical Data.....	4
3. Electrical Circuit Diagram.....	5
4. Safety Precautions.....	5
5. Important Precautions.....	6
6. Installation Instructions.....	6
7. Operating Your Beverage Refrigerator.....	6
8. Care and Maintenance.....	6
9. Trouble Shootings.....	7
10. Warranty.....	8

Your Beverage Refrigerator

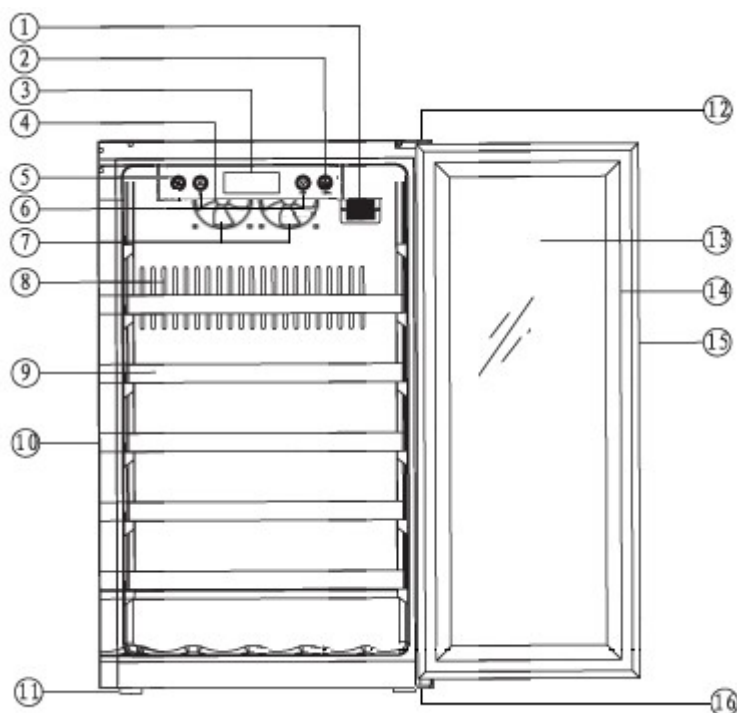

- | | |
|------------------------------|-----------------|
| 1. NTC Point | 9. Shelf |
| 2. Light Switch | 10. Body |
| 3. Temperature Display | 11. Foot |
| 4. Light | 12. Upper hinge |
| 5. Celsius/Fahrenheit Switch | 13. Glass |
| 6. Temperature Setting | 14. Door Seal |
| 7. Fan | 15. Handle |
| 8. Exhaust Window | 16. Lower Hinge |

Technical Data

Model No.	PH-CBR100
Capacity	100L
Voltage	110~120V
Current	1.2 A
Frequency	60Hz
Protection Class	I
Climate Class	T/ST/N/SN
Input Power	90W
Power Consumption(KW.h/24h)	0.51 KW.h/24h
Temperature Control Range	3-10°C(38°F-50°F)
Net Weight	78.2 lbs
Gross Weight	99 lbs
Product Size(W×H×D)	15.5''(W) x 33.1''(H) x 22.8''(D)
Packing Size(W×H×D)	18.7''(W) x 35.4''(H) x 26.0''(D)

Electrical Circuit Diagram

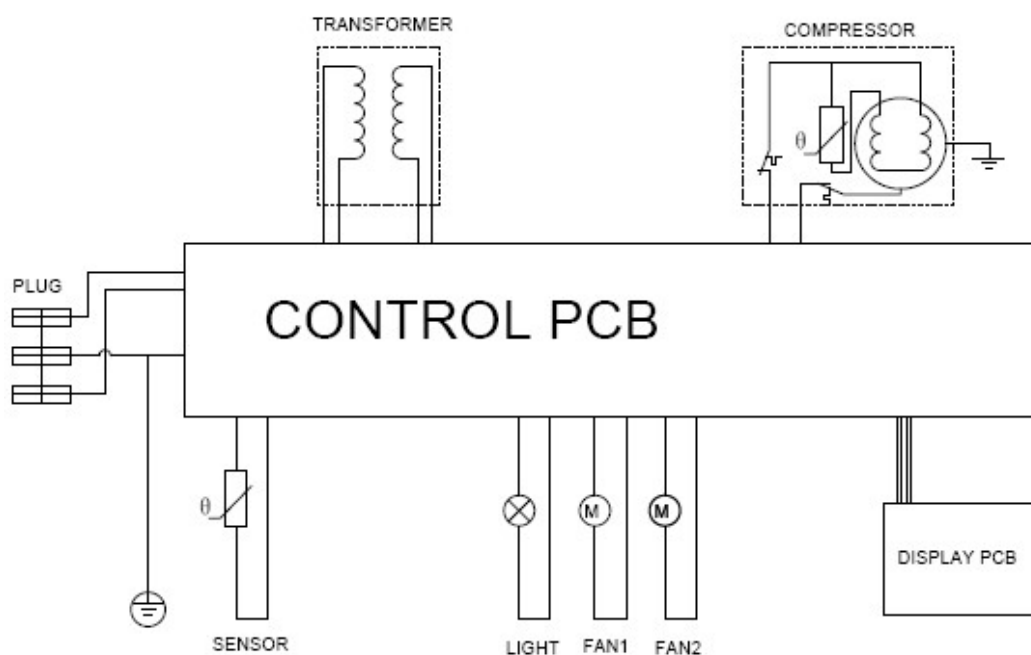

Safety Precautions



WARNING



To reduce the risk of fire, electrical shock, or injury when using your appliance, follow these basic precautions;

- **PLEASE READ** all instructions before installing, operating, and servicing the appliance.
- **Danger and Warning:** Failure to follow this safety statement will result in severe personal injury or death, property or equipment damage.
- **RISK OF CHILD ENTRAPMENT.** Before you throw away your old beverage refrigerator, take off the doors and leave shelves in place so children may not easily climb inside.
- **RISK OF CHILD BE INJURED.** Never allow children to put their fingers through any exhaust window.
- **⚠️ SHOCK HAZARD** - Electrical grounding required.
- Never attempt to repair or perform maintenance on the unit until the electricity has been disconnected.
- Never remove the round grounding prong from the plug and never use a two-prong grounding adaptor.
- Altering, cutting of power cord, removal of power cord, removal of power plug, or direct wiring can cause serious injury, fire or loss of property or life, and will void the warranty.
- Never use an extension cord to connect power to the unit.
- Always keep a dry working area for your refrigerator.

Important Precautions

- Do not lift the unit by door handle.
- Do keep the door closed before installing into the cabinet.
- Allow unit temperature to stabilize for 24 hours before use.
- Do not block any internal fans.
- Use only genuine supplier's replacement parts. Imitation parts can damage the unit, affect its operation or performance and may void the warranty.

Installation Instructions

Before using your beverage refrigerator:

- Remove the exterior and interior packing.
- Clean the interior surface with lukewarm water using a soft cloth.
- Before connecting the appliance to the power outlet, let it stand upright for approximately 2 hours. This will reduce the possibility of a malfunction in the cooling system from handling during transportation.
- Place your beverage refrigerator on a floor that is strong enough to hold the appliance when it is fully loaded.
- To level your appliance, adjust the front legs at the bottom of it.

Operating Your Beverage Refrigerator

How to use the press-buttons on the Display Panel:

You can set the temperature as your desire by pressing the button. There are three press-button on the panel “▲” and “▼” to adjust the temperature by 1°C or 1°F between 3°C -10°C or 38°F-50°F.

You can turn the interior light on or off by pressing the “Light” button.

Care and Maintenance

Cleaning your beverage refrigerator

- Unplug the beverage refrigerator and remove the bottles.
- Wash the inside with a warm water or baking soda solution. The solution should be about 2 tablespoons of baking soda to a quart of water.
- The outside of beverage refrigerator should be cleaned with mild detergent or warm water.
- Draw out the water box at the bottom, and wash.

Moving your beverage refrigerator

- Remove all the bottles.
- Securely tape down all loose items inside your beverage refrigerator.
- Turn the leveling legs up to the base to avoid damage.
- Tape the door.
- Be sure the beverage refrigerator stays in the upright position during transportation.

Trouble Shooting

You can solve many common beverage refrigerator problems easily, saving you the cost of a possible service call. Try the suggestion below to see if you can solve the problem before calling the service center.

PROBLEM	POSSIBLE CAUSE
Beverage refrigerator do not operate.	Not plugged in using different voltage. The circuit breaker tripped or a blown fuse.
Beverage refrigerator is not cold enough.	Check the temperature control setting. The door is open too often. The door is not closed completely. The door seal does not seal properly. The beverage refrigerator does not have the correct clearance.
The light does not work.	Main control board does not work. PCB Problem. There is some problem with the plug.
Vibrations.	Check to assure that the beverage refrigerator is leveled.
The beverage refrigerator seems to make to much noise	The beverage refrigerator is not leveled. Check the fan.
The door will not close properly.	The beverage refrigerator is not leveled. The doors were reversed and not properly installed. The seal is weak. The shaves out of position.
LED could not display.	Main control board does not work. PCB Problem. There is some problem with the plug.
LED display error.	Weak quality of display. Temperature point is out off.
Buttons are not functional.	Temperature controller panel is damaged.

PHIESTINA LIMITED WARRANTY

Full One Year Warranty

Warranty Terms:

The manufacture warrants to the original purchaser of this product that the product will be free from manufacturing defects in workmanship and material for a period of 1 year from the date of original purchase when this major appliance is operated and maintained according to instructions attached to or furnished with the product.

The purchaser must contact the manufacture Customer Service Department and provide a description of the defective part, including digital pictures if requested, with buying channel, serial number, order ID and the original purchase documentation as validation of warranty coverage date.

Once confirmed that your appliance is eligible for the warranty service, Phiestina Customer Service Department will contact you by mail or phone about the maintenance solution. Replacement parts and/or units will be new, re-manufactured or refurbished and is subject to the manufacturer's discretion. Phiestina is not responsible for damage resulting from shipper mishandling or improper packing. Do not return a defective product to the place of purchase. Product received without a return authorization number will be refused.

After receiving the unit, please do not remove, altered original model/serial number, that will influence the after-sale service. Please carefully keep the user manual and warranty card for future reference.

If you need service, first see the "Troubleshooting" section of the User Manual. After checking, you may find additional help by mailing or calling us.

Write down the following information about your product to better help you obtain assistance or service if you ever need. You can find this information on the model and serial number located on the product.

Dealer name _____

Model number _____

Serial number _____

Order number _____

Purchase date _____

Warranty Exclusions:

The warranty will not apply if damage is caused by any of the following:

1. Damage to the product due to misuse, mishandling and abuse.
2. Product not assembled or installed according to manufacturer's instruction.
3. Repairs by unauthorized persons or service centers with unauthorized spare parts.
4. Failure to provide reasonable and necessary maintenance.
5. Improper power supply such as low voltage, defective household wiring or inadequate fuses.
6. Accident, alteration, misuse or abuse of the appliance such as using non-approved accessories, inadequate air circulation in the room or abnormal operating conditions, such as extreme temperatures.
7. Damage in transit or when moving the appliance.
8. Use of force or damage caused by external influences.
9. Store improper things.
10. Normal wear and tear.

11. Cosmetic damage, including scratches, dents, chips, or other damage to the finish of your product, unless such damage results from defects in materials or workmanship and is reported to us within 30 days from the date of purchase.
12. Fire, water damage, theft, war, riot, hostility or acts of God such as hurricanes, floods, etc. In addition consequential damage and incidental damages, such as damage to person or property are not coverable under this warranty.
13. Partially or completely dismantled appliances.

To obtain service or information, please call 866-675-2011 or send email to
service@phiestina.com

Product contents and specifications may change without notice.

Copyright © 2017 Phiestina Products