



# Leigh







## Country

Authentic Country Living

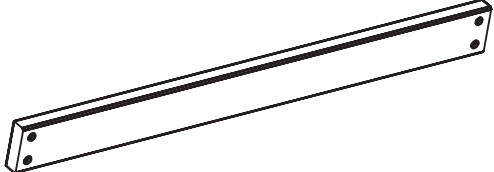
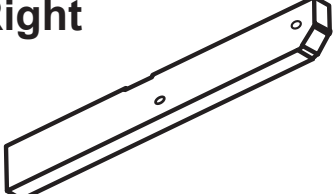
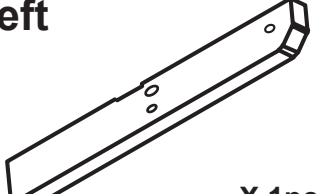
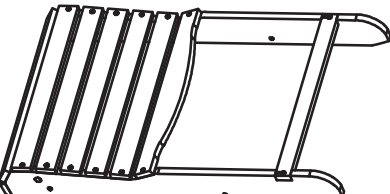
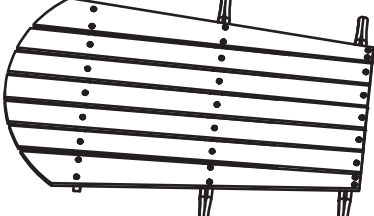
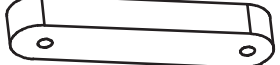
### FOLDING ADIRONDACK CHAIR

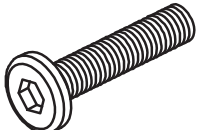
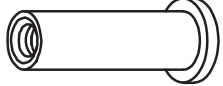
ITEM # TX 36600 & TX 39010

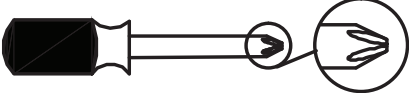
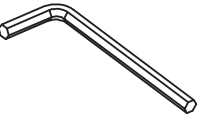
## PARTS AND HARDWARE LIST

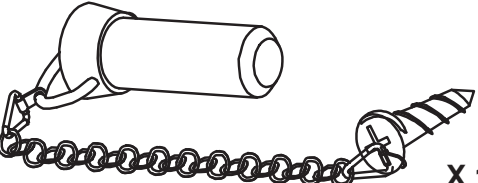
<b>① FRONT SUPPORT BAR</b>	<b>② FRONT LEG</b>	<b>③ FRONT LEG</b>		
 <p style="text-align: right;">X 1pc</p>	Right  <p style="text-align: right;">X 1pc</p>	Left  <p style="text-align: right;">X 1pc</p>		
<b>④ SEAT PANEL</b>	<b>⑤ BACK PANEL</b>	<b>⑥ BRACE</b>		
 <p style="text-align: right;">X 1pc</p>	 <p style="text-align: right;">X 1pc</p>	 <p style="text-align: right;">X 2pcs</p>		
<b>⑦ LEFT ARM</b>	<b>⑧ RIGHT ARM</b>	<b>Ⓐ BOLT: M8x35</b>	<b>Ⓑ NUT: M8x20</b>	<b>Ⓒ WASHER</b>
 <p style="text-align: right;">X 1pc</p>	 <p style="text-align: right;">X 1pc</p>	1.4"  <p style="text-align: right;">X 10pcs</p>	.8"  <p style="text-align: right;">X 6pcs</p>	M8/Ø19x2  <p style="text-align: right;">X 6pcs</p>
<b>Tools Required For Assembly</b>		<b>Tool Included</b>	<b>Ⓓ SCREW: M4x40</b>	<b>Ⓔ WASHER &amp; LOCKING PIN</b>
 <p style="text-align: center;"><b>Phillips Screwdriver</b></p>		 <p style="text-align: right;">X 1pc</p>	 <p style="text-align: right;">X 4pcs</p>	 <p style="text-align: right;">X 1pc</p>
<p style="text-align: center;"><b>Do not use power tools because they may damage the hardware or split the wood.</b></p>				

# STEP 1

Attach Leg Support (1) to the front legs (2&3) with the Screws (D).

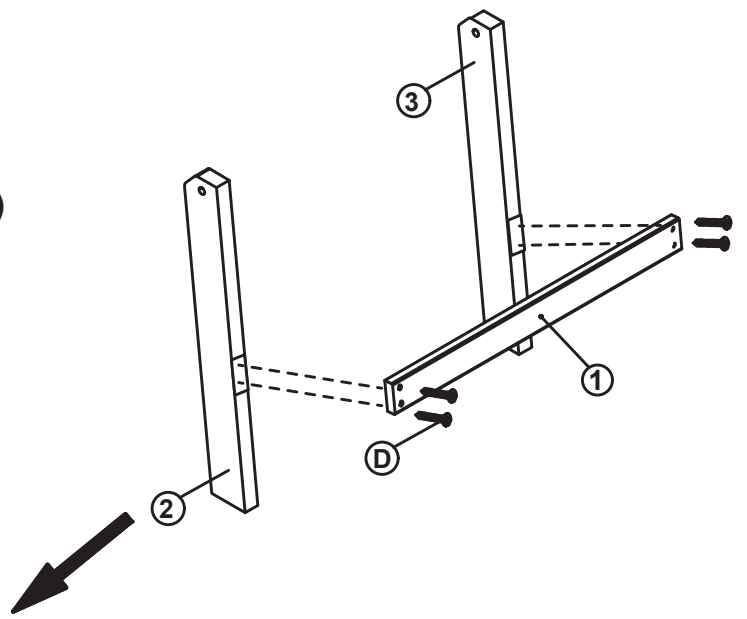

# STEP 2

Attach Seat Panel (4) to the Front Left Leg (3) with Bolt (A), Nut (B) and Washer (C). Repeat for the Right Leg (2). Attach Bolt (A), Nut (B) and Locking Pin & Washer (E) to the left side of the Front Left Leg (3).

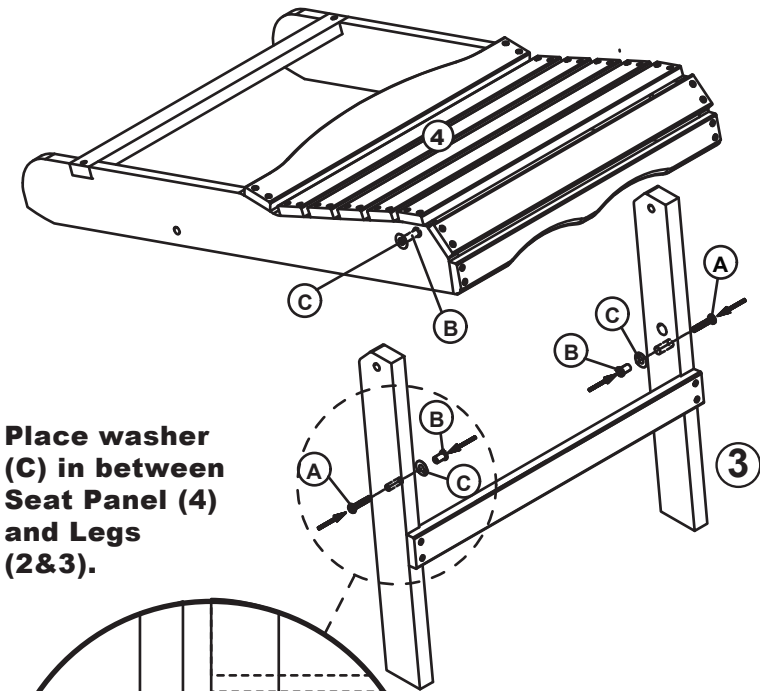

Place washer (C) in between Seat Panel (4) and Legs (2&3).

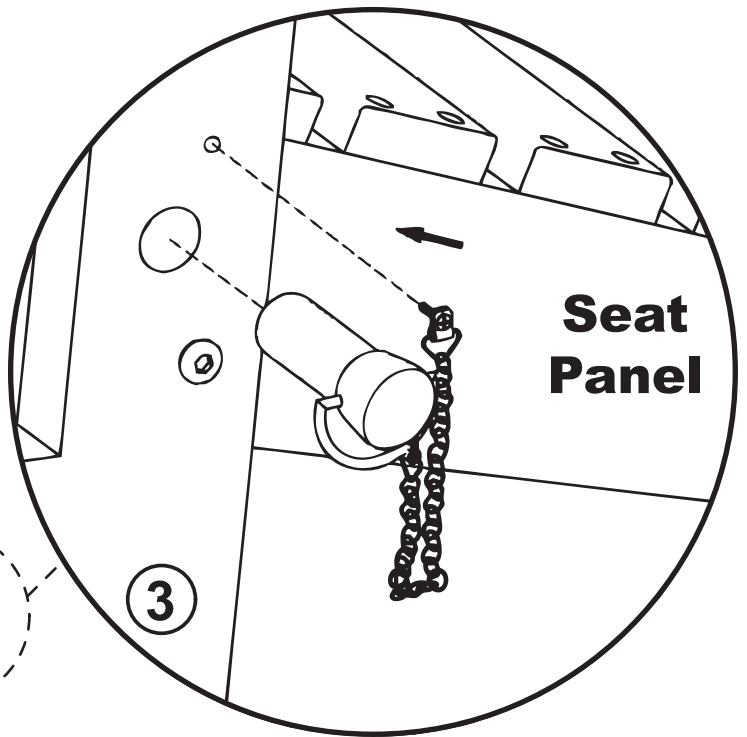
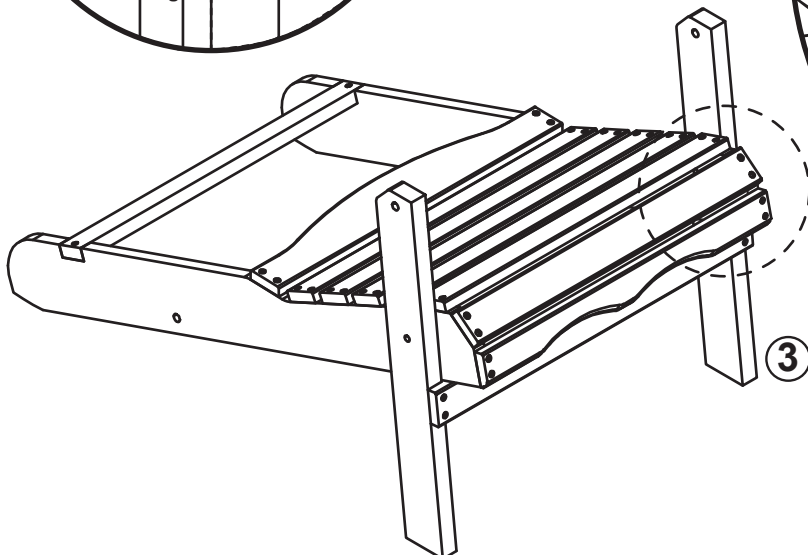
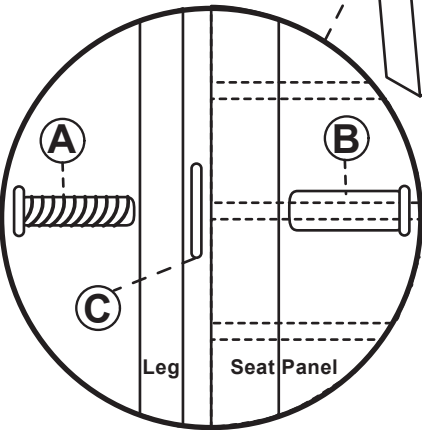

# STEP 3

Attach Back Panel (5) to the Braces (6) with 2 Bolts (A).

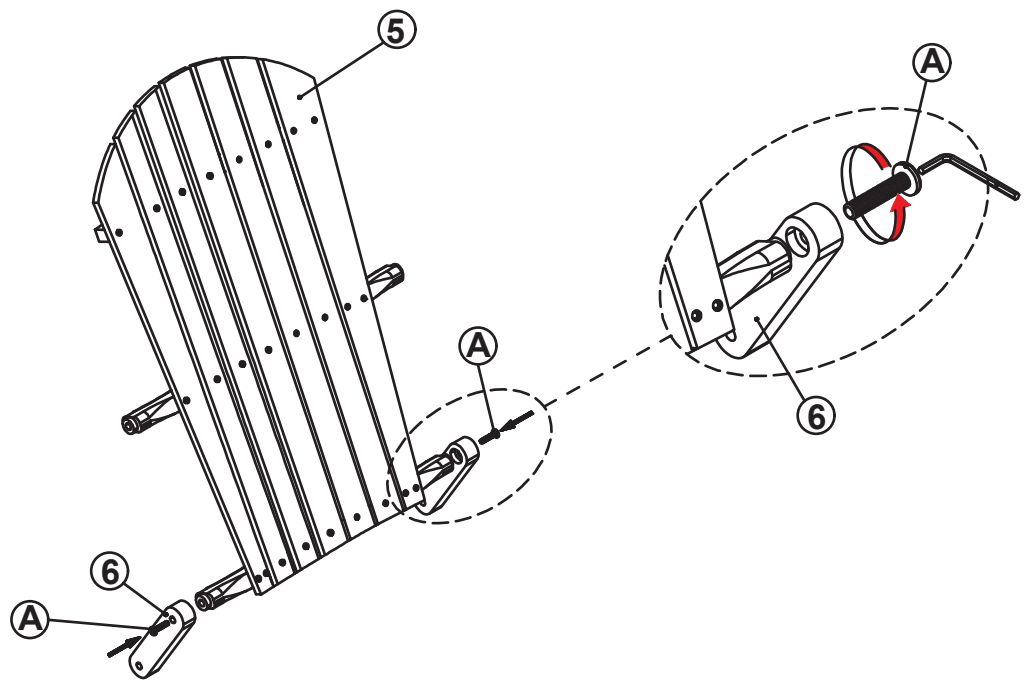

# STEP 4

Attach Braces (6) to the Seat Panel (4) with 2 Bolts (A), Nuts (B) and Washers (C).

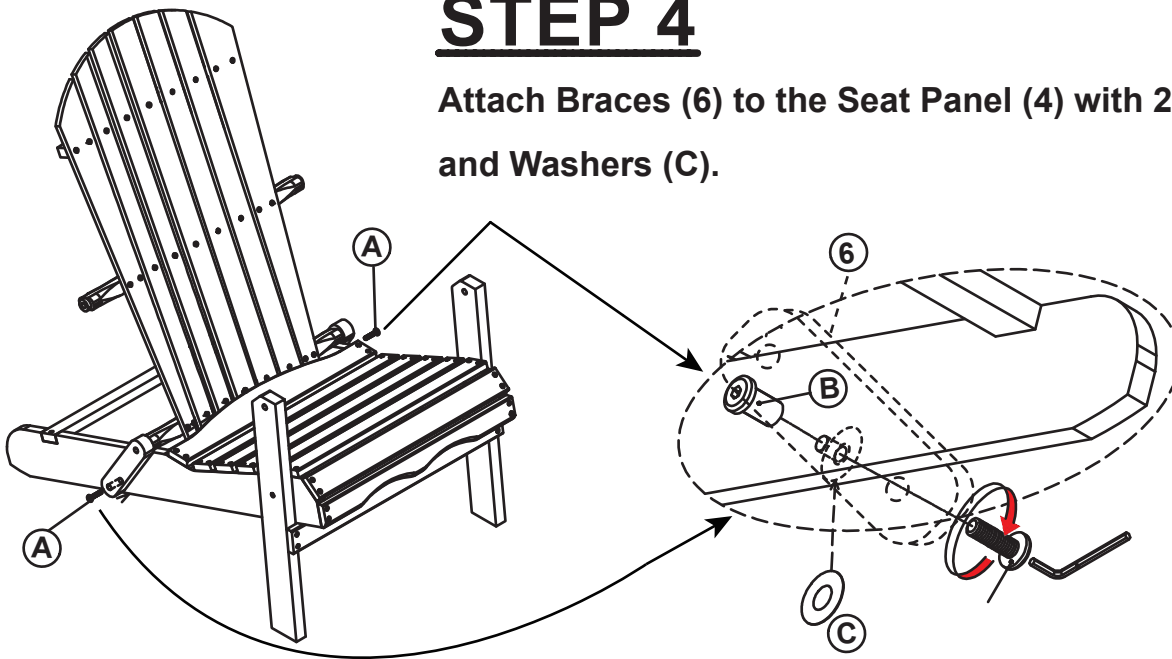

Place Washer (C) in between the Seat Panel (4) and the Bracer (6) pieces.

# STEP 5

Attach the Right Arm (8) and the Left Arm (7) to the Front Legs (2&3) with 2 Bolts (A), Nuts (B) and Washers (C). Then attach the Right Arm (8) and the Left Arm (7) to the Back Panel (5) with 2 Bolts (A).

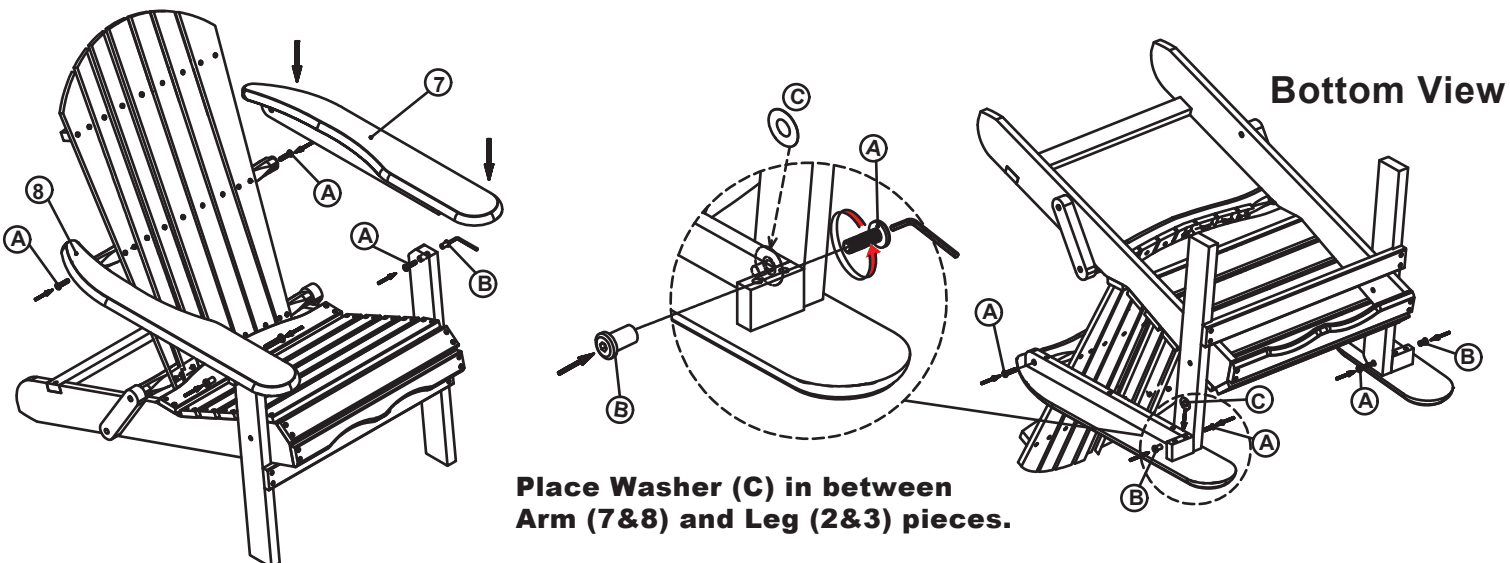

Place Washer (C) in between Arm (7&8) and Leg (2&3) pieces.

# Limited Warranty and Care Instructions

## LIMITED ONE YEAR WARRANTY (NON-TRANSFERABLE)

This product is covered under United General Supply's (UGS) one (1) year limited warranty. To the original purchaser of this piece of furniture, cooler or accessory; UGS warrants that it will be free from defects in material and workmanship for up to one year from the date of purchase under normal use and proper care.

Replacement of defective or missing parts will be sent at no charge to the customer for a period of 30 days from the date of purchase. UGS will no longer be responsible for missing parts or hardware 30 days after date of purchase. Freight, packaging, labor or material charges to and from our customer service center is not covered under the warranty and is therefore the customer's responsibility.

The limited warranty does not cover this piece of furniture, cooler or accessory for commercial purposes, abusive use, damage by modification, freeze damage, rust, fading and issues caused by improper care.

For minor defects or missing parts/hardware, please contact customer service immediately upon purchase. Please do not return product to the store unless you are completely unsatisfied with the product, or if the damage is irreparable. A customer service agent may help determine whether the damage is repairable and will provide further instructions. For returns and refunds, please refer to your local store with proof of purchase for such cases.

**Proof of purchase (dated register receipt) will be required for warranty claims.**

## PROPER CARE INSTRUCTIONS

If left untreated, wood will naturally weather. During long periods of non-use, store furniture or cooler in covered and dry place. For the least maintenance, place your furniture, cooler, or accessory under a covered area.

To preserve and maintain the original finish of this natural furniture piece, a natural tung/linseed/Danish oil (with stain), which can be found at your local hardware store, should be applied. Please note the cooler/furniture has been stained and oiled before being packaged. If the wood is not maintained, the wood will naturally grey in color.

Remove the cooler/furniture completely from sunlight prior to applying oil. Apply generously and remove any excess oil with cloth.

For all painted wood finish products, we recommend that you use a latex based paint the matching color, Before painting, a light sanding with a fine grit sandpaper might be necessary to prep your product for a new paint coating.

Customer Service may be reached Monday through Friday from 9:00a.m. to 5:00p.m. CST.

HELP@UGSCO.COM OR 1-877-87LEIGH (53444)



DISTRIBUTED BY:  
UNITED GENERAL SUPPLY CO., INC.  
HOUSTON, TX 77036

[www.LeighCountry.com](http://www.LeighCountry.com)