

INSTRUCTION MANUAL

DRESSER

Model No:

DL8417-1

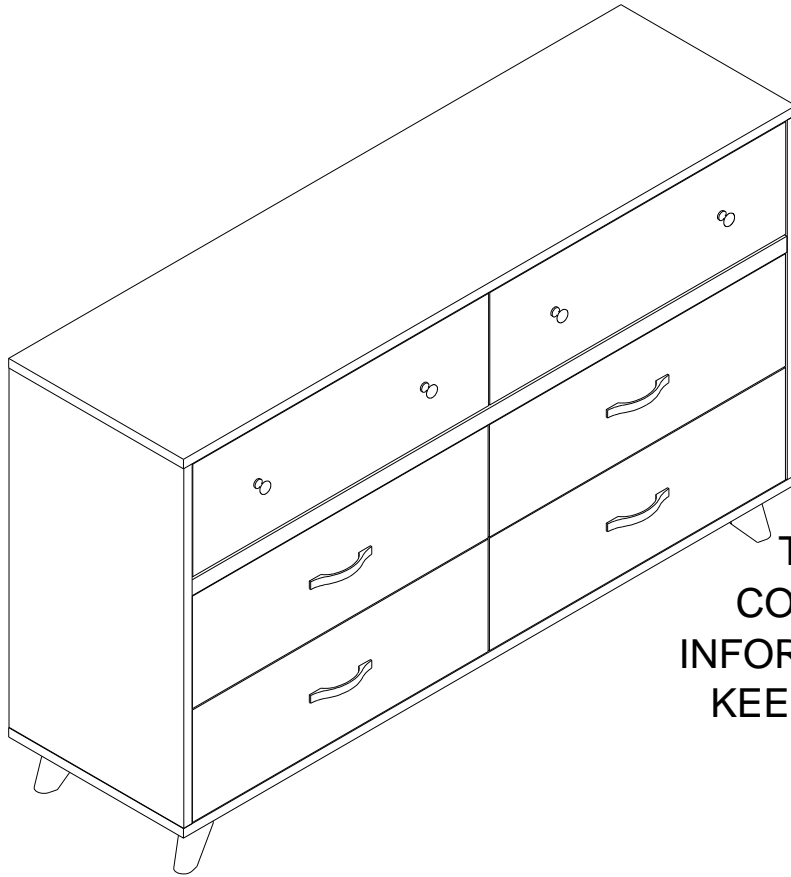

UPC CODE:

0-65857-19826-3

NOTE:

THIS INSTRUCTION BOOKLET
CONTAINS **IMPORTANT** SAFETY
INFORMATION. PLEASE READ AND
KEEP FOR FUTURE REFERENCE.

Lot number:

(TAKEN FROM CARTON)

Date of purchase:

____ / ____ / ____

**NOV
OGR
ATZ**

DO NOT RETURN PRODUCT TO THE RETAILER.
If a part is missing or damaged, contact our customer
service department. We will replace the part **FREE** of
charge.



Tel #: 1-800-295-1980
E-Mail: das@dorel.com

CUSTOMER SERVICE

You can also contact us by writing to the address listed below. Please include the product model number, color and a detailed description of your enquiry.

Dorel Living - Customer Service Department
12345 Albert-Hudon Boulevard, Suite 100
Montreal, Quebec
Canada, H1G 3L1

NOTES AND INSTALLATION

Ensure all parts and components are present before beginning assembly.

Assemble on a soft, smooth surface to prevent damage to the product finish.

Use the wall safety strap provided to secure the unit to the wall.

A Phillips head screw driver is not included.

DO NOT use power tools.

CAUTION: Adult assembly required.

Assembly will require two people.

To avoid unnecessary damage, when levelers have been extended, **DO NOT** drag across surface when moving. Be sure to lift and carry the item to its location.

Estimated assembly time: 60 minutes.

⚠ WARNING	
	Serious or fatal crushing injuries can occur from furniture tip-over. To help prevent tip-over:
	<ul style="list-style-type: none">• Install tip-over restraint provided.• Place heaviest items in the lowest drawers.• Do not set TV's or other heavy objects on top of this product, unless the product is specifically designed to accommodate them.• Never allow children to climb or hang on drawers, doors, or shelves.• Never open more than one drawer at a time.
	Use of tip-over restraints may only reduce, but not eliminate, the risk of tip-over. <i>This is a permanent label. Do not remove!</i>

CARE, CLEANING AND MAINTENANCE

Dust regularly with a soft, lint-free cloth to prevent soil build-up. A damp cloth may be used occasionally to clean surface. Dry immediately. Do not use any abrasives that may damage finish. Excessive exposure to sunlight and extreme changes in temperature and moisture can damage wood furniture.

Check all bolts, screws and fasteners periodically and tighten them if necessary.

1-YEAR LIMITED WARRANTY

Dorel warrants its product to be free from defects in material and workmanship and agrees to remedy any such defect. This warranty covers 1 year from the date of original purchase from authorized retailers. This warranty is valid only upon presentation of proof of purchase. This is solely limited to the repair or replacement of defective furniture components and no assembly labor is included. This warranty does not apply to any product which has been improperly assembled, subjected to misuse or abuse or which has been altered or repaired in any way. The warranty does not cover wearing, tearing, fading or splitting of the fabric (where applicable). This warranty gives you specific legal rights and you may also have other rights which vary from State to State or Province to Province.







WARNING: Should this product become damaged, and/or components are broken or missing, DO NOT USE.

DRESSER

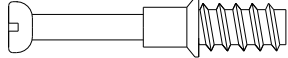
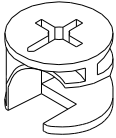
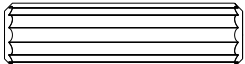
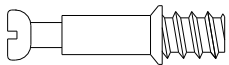
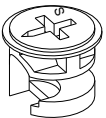
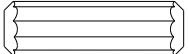
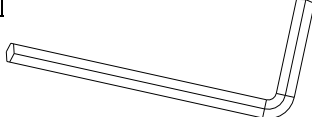
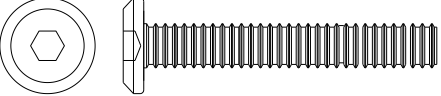
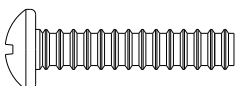
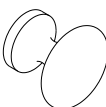
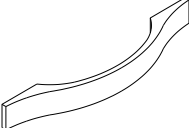
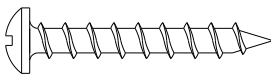
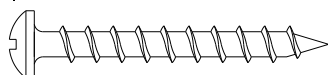
DL8417-1

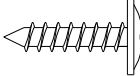
HARDWARE LIST

<p>1</p> 	<p>2</p> 	<p>3</p>  <p>Ø8 X 30mm</p>
<p>CAM BOLT 22 PCS</p>	<p>CAM LOCK 22 PCS</p>	<p>WOOD DOWEL 30 PCS</p>
<p>4</p> 	<p>5</p> 	<p>6</p>  <p>Ø6 X 20mm</p>
<p>CAM BOLT 36 PCS</p>	<p>CAM LOCK 36 PCS</p>	<p>WOOD DOWEL 36 PCS</p>
<p>7</p> 	<p>8</p>  <p>Ø1/4" X 40mm</p>	
<p>ALLEN KEY 1 PC</p>	<p>BOLT 21 PCS</p>	
<p>9</p>  <p>Ø9 X 4 X 20mm</p>	<p>10</p> 	<p>11</p> 
<p>BOLT 12 PCS</p>	<p>KNOB 4 PCS</p>	<p>HANDLE 4 PCS</p>
<p>12</p>  <p>Ø8 X 4 X 30mm</p>	<p>13</p>  <p>Ø8 X 4 X 35mm</p>	<p>14</p>  <p>Ø8 X 8mm</p>
<p>SCREW 4 PCS</p>	<p>SCREW 24 PCS</p>	<p>PLASTIC BARREL NUT 24 PCS</p>
<p>15</p>  <p>M3 X 15mm</p>	<p>16</p> 	
<p>SCREW 20 PCS</p>	<p>SAFETY STRAP 2 PACKS</p>	

DRESSER

DL8417-1

PARTS LIST

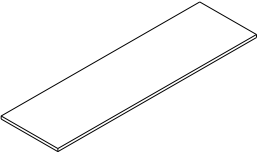
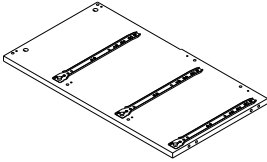
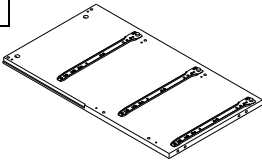
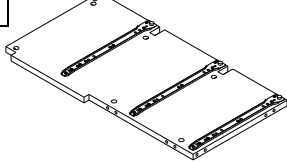
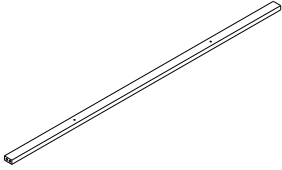
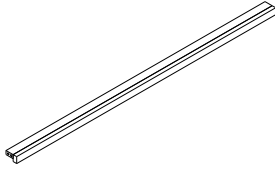
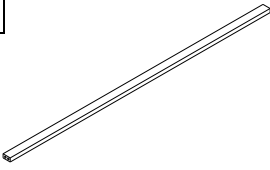
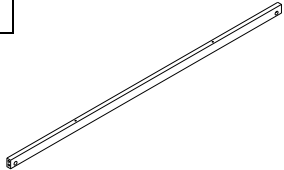
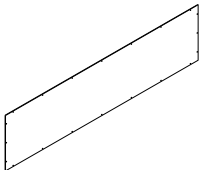
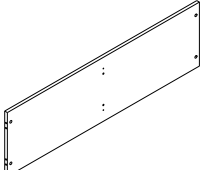
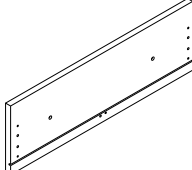
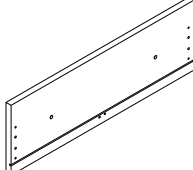
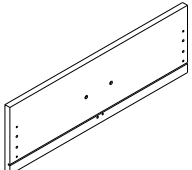
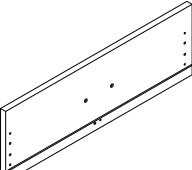
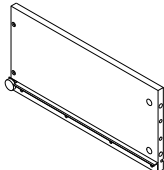
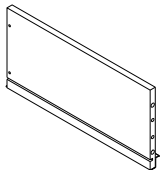
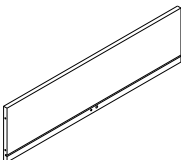
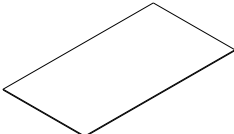
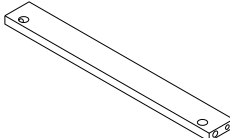
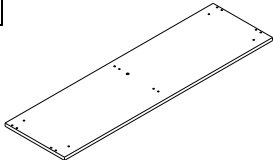
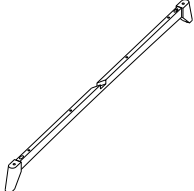
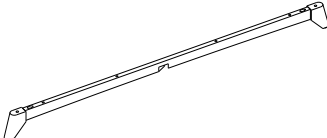
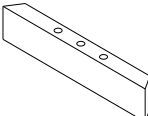
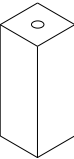
<p>A</p> 	<p>B</p> 	<p>C</p> 	<p>D</p> 
<p>TOP PANEL 1 PC</p>	<p>LEFT SIDE PANEL 1 PC</p>	<p>RIGHT SIDE PANEL 1 PC</p>	<p>MIDDLE PANEL 1 PC</p>
<p>E</p> 	<p>F</p> 	<p>G</p> 	<p>H</p> 
<p>FRONT TOP RAIL 1 PC</p>	<p>FRONT MIDDLE RAIL 1 PC</p>	<p>FRONT BOTTOM RAIL 1 PC</p>	<p>BACK TOP RAIL 1 PC</p>
<p>I</p> 	<p>J</p> 	<p>K</p> 	<p>L</p> 
<p>BACK TOP PANEL 1 PC</p>	<p>BACK BOTTOM PANEL 1 PC</p>	<p>LEFT TOP DRAWER FRONT 1 PC</p>	<p>RIGHT TOP DRAWER FRONT 1 PC</p>
<p>M</p> 	<p>N</p> 	<p>O</p> 	<p>P</p> 
<p>LEFT BOTTOM DRAWER FRONT 2 PCS</p>	<p>RIGHT BOTTOM DRAWER FRONT 2 PCS</p>	<p>DRAWER LEFT SIDE 6 PCS</p>	<p>DRAWER RIGHT SIDE 6 PCS</p>
<p>Q</p> 	<p>R</p> 	<p>S</p> 	<p>T</p> 
<p>DRAWER BACK 6 PCS</p>	<p>DRAWER BOTTOM 6 PCS</p>	<p>DRAWER BOTTOM RAIL 6 PCS</p>	<p>BOTTOM PANEL 1 PC</p>
<p>U</p> 	<p>V</p> 	<p>W</p> 	<p>Y</p> 
<p>BASE BOTTOM RAIL 1 PC</p>	<p>BASE TOP RAIL 1 PC</p>	<p>STRETCHER RAIL 2 PCS</p>	<p>SUPPORT LEG 1 PC</p>

DRESSER DL8417-1

STEP 1

Insert cam bolt (1) into the left and right side panel (B & C) using a Phillips head screwdriver (not included) as shown.

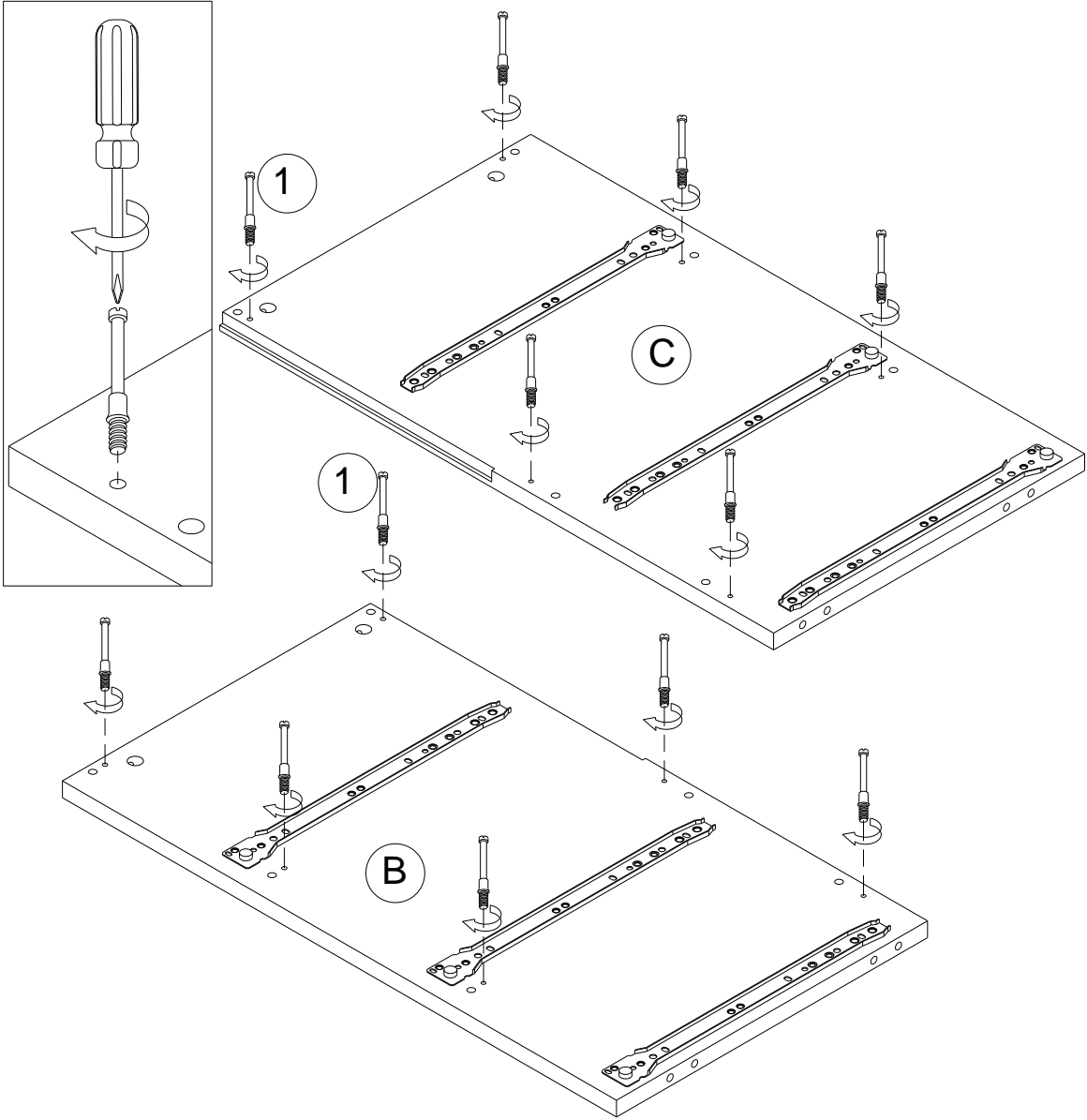

1		12 PCS
---	--	--------

DRESSER DL8417-1

STEP 2

Insert cam bolt (1) into the back bottom panel (J), front middle rail (F) and front bottom rail (G) using a Phillips head screwdriver (not included) as shown.

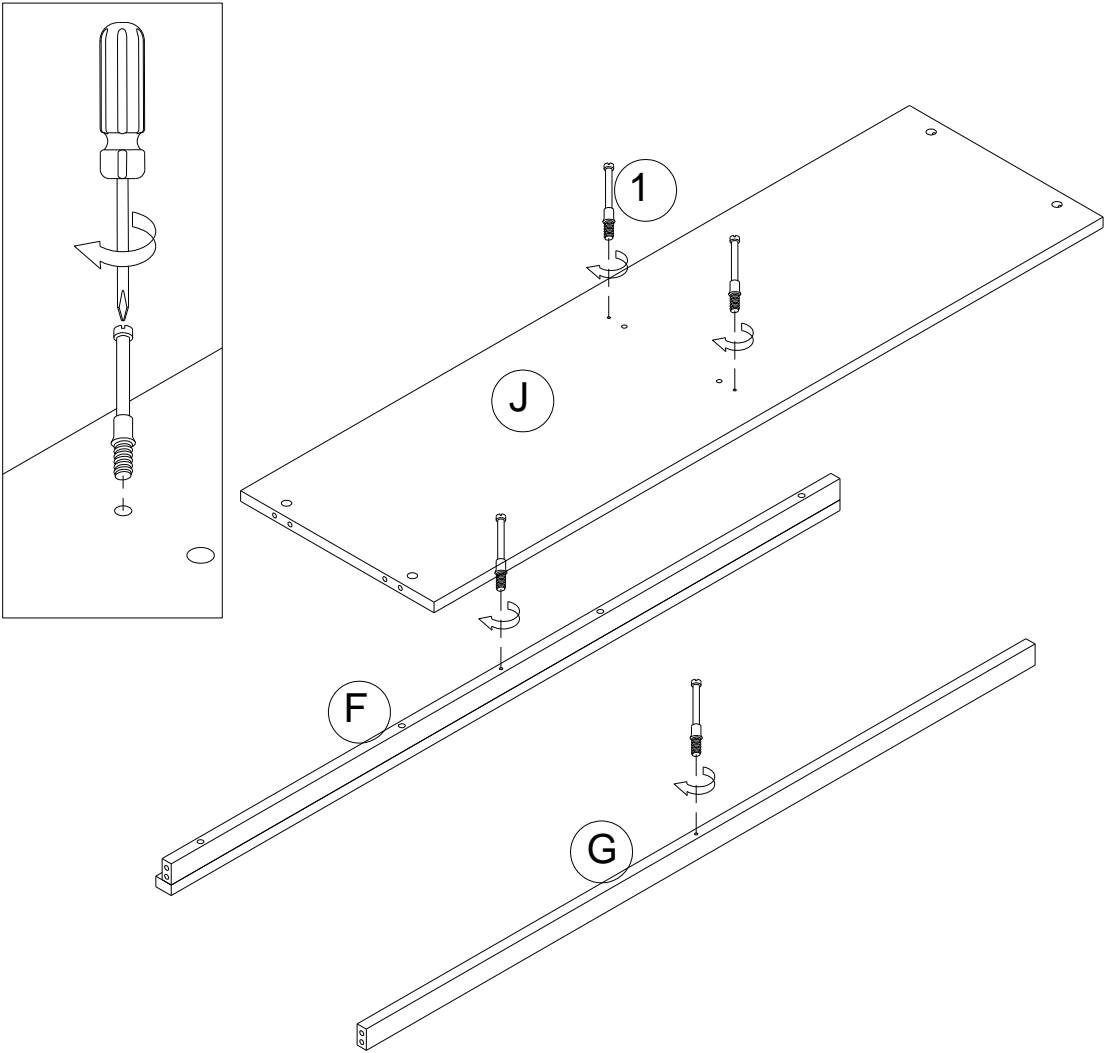

1		4 PCS
---	--	-------

DRESSER DL8417-1

STEP 3

Insert wood dowels (3) and cam locks (2) into middle panel (D) as shown.
Secure middle panel (D) to the back bottom panel (J) by rotating the cam locks 1/2 turn clockwise using a Phillips head screwdriver (not included)

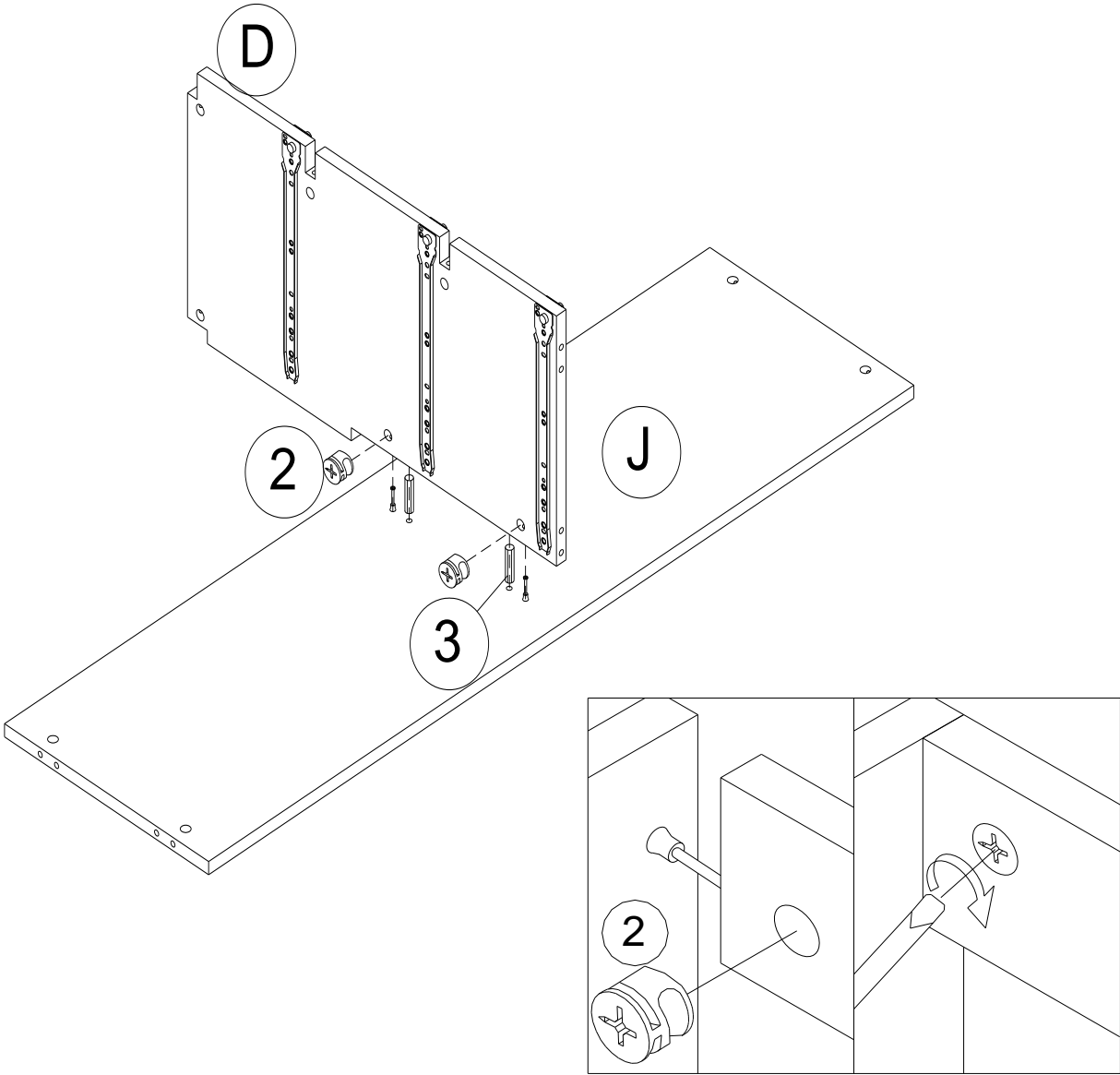

2		2 PCS
3		2 PCS

DRESSER DL8417-1

STEP 4

Insert cam locks (2) and wood dowels (3) to rails (E, F, G & H), back bottom panel (J) and side panels (B & C) as shown.

Connect rails (E, F, G & H) to middle panel (D) as shown.

Secure the rails (E, F, G & H) to middle panel (D) by rotating the cam locks (2) 1/2 turn clockwise using a Philip head screwdriver (not included).

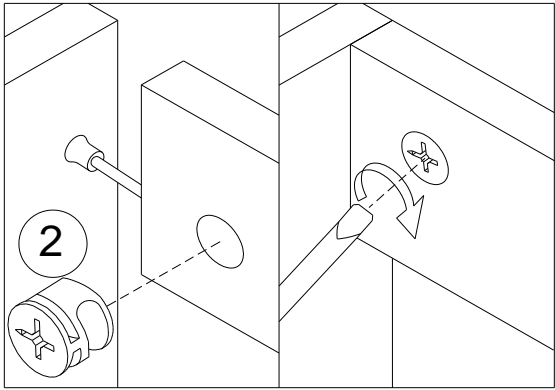
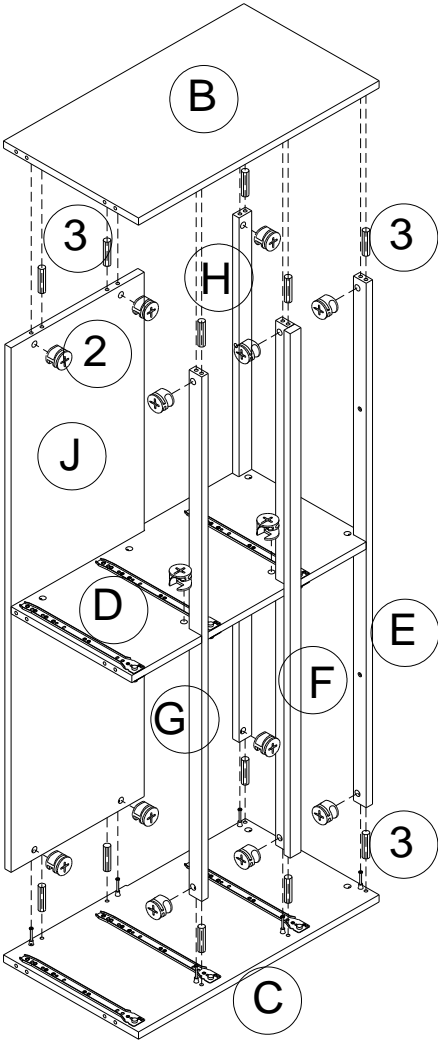

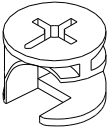
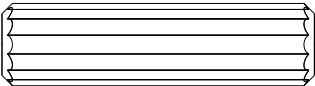
2		14 PCS
3		12 PCS

DRESSER

DL8417-1

STEP 5

Insert wood dowels (3) into the bottom panel (T).
 Attach stretcher rails (W), base bottom rail (U), base top rail (V) and support leg (Y) to the bottom panel (T) with bolts (8). Use Allen key (7) to tighten the bolts.

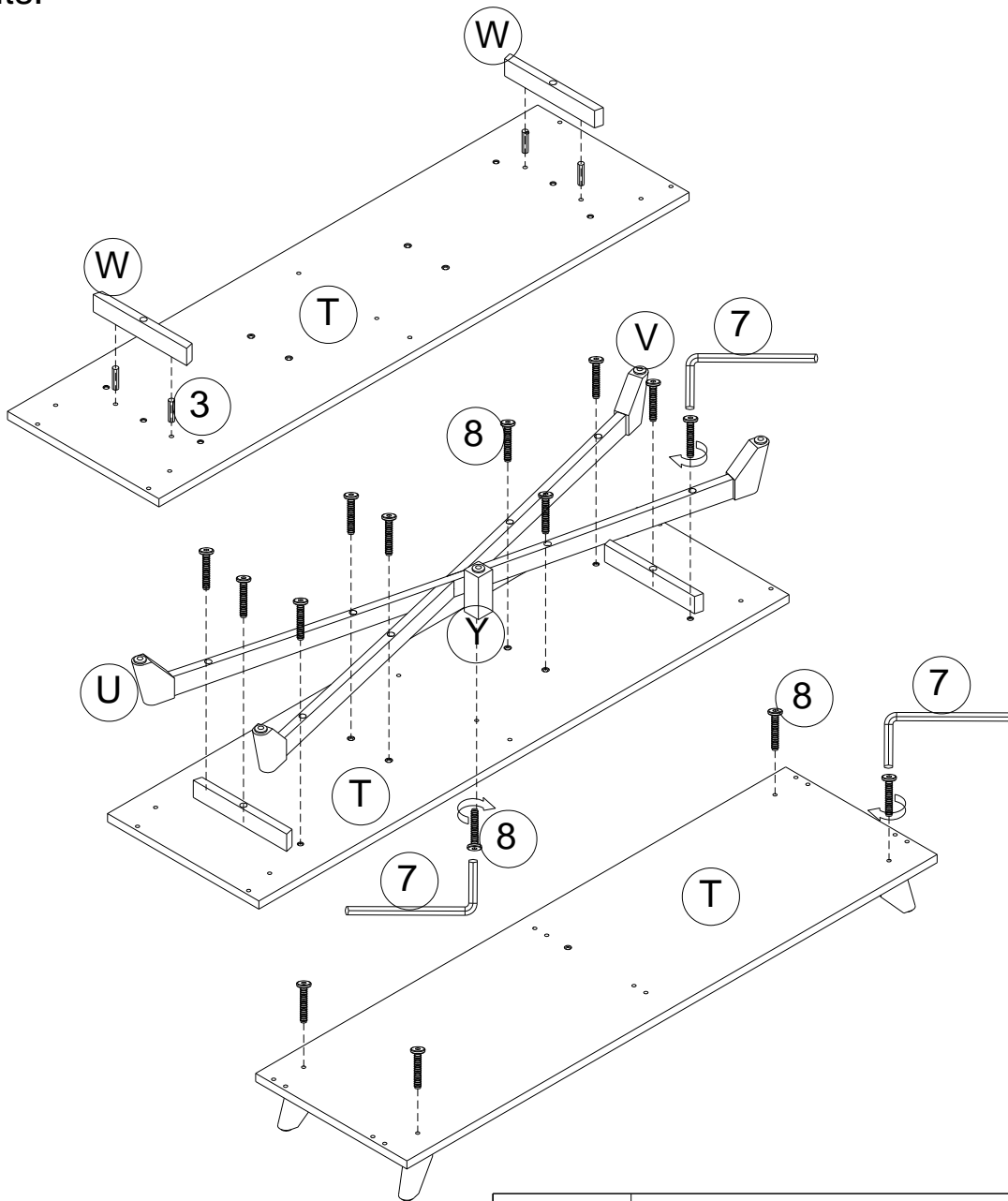

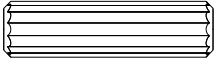
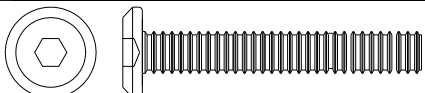
3		4 PCS
8		15 PCS

DRESSER

DL8417-1

STEP 6

Insert wood dowels (3) into bottom panel (T).

Attach bottom panel (T) to the side panels (B & C) and middle panel (D) with bolts (8). Use Allen key (7) to tighten the bolts.

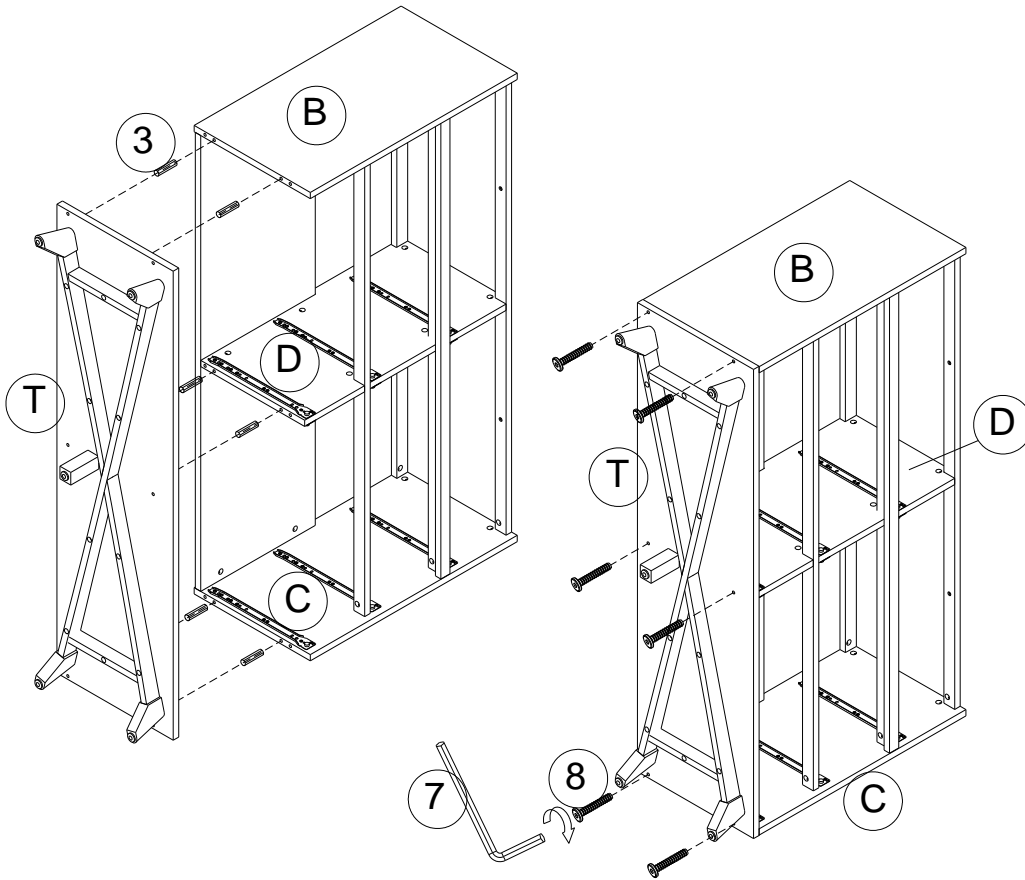

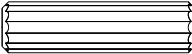
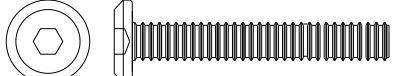
3		6 PCS
8		6 PCS

DRESSER

DL8417-1



STEP 7

Insert cam locks (1) into top panel (A) as shown.

Insert cam locks (2) and wood dowels (3) into side panels (B & C) and middle panel (D) as shown. Attach top panel (A) to the unit and secure by rotating the cam locks (2) 1/2 turn clockwise using a Phillips head screwdriver (not included).

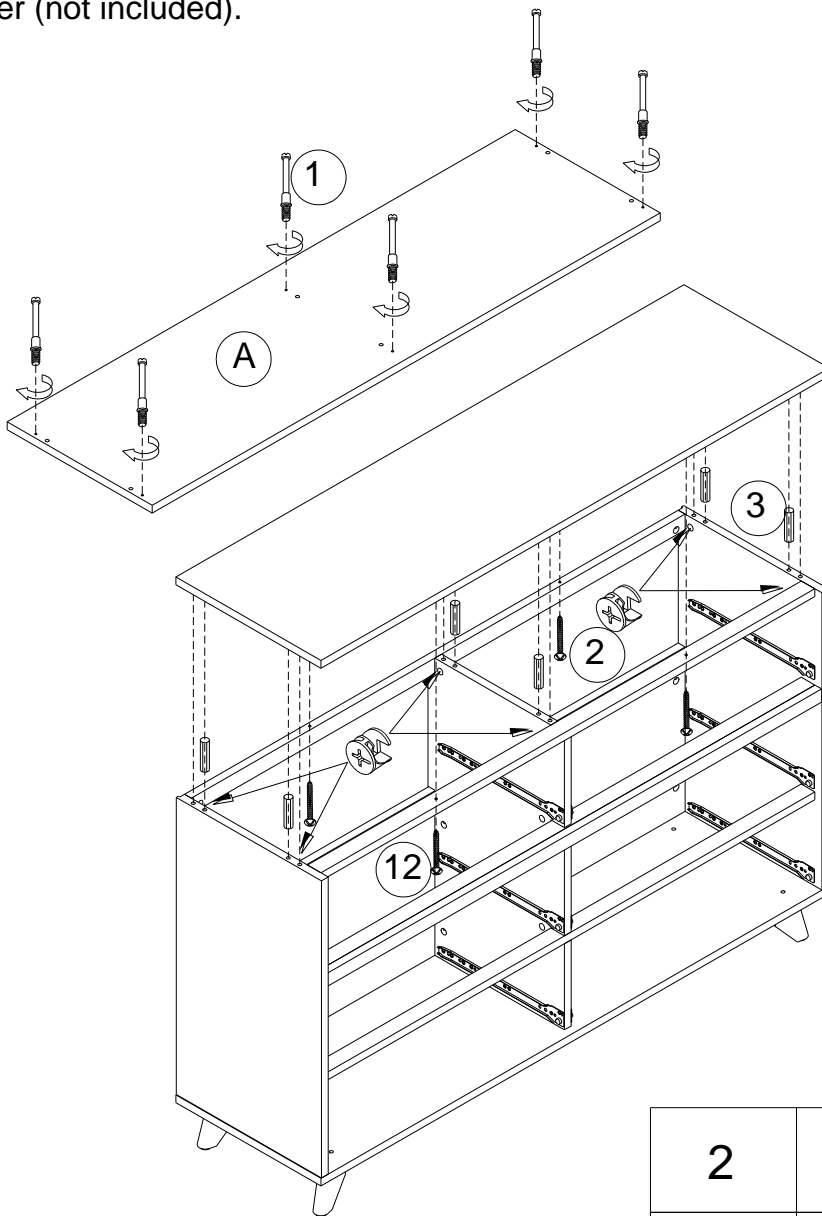
Further secure top panel (A) to the assembled unit with screws (12) using a Phillips head screwdriver (not included).

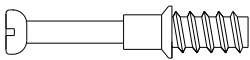

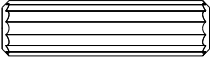
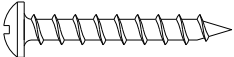
1		6 PCS	2		6 PCS
			3		6 PCS
			12		4 PCS

DRESSER DL8417-1

STEP 8

Attach back top panel (I) to the assembled unit with screws (15) using a Phillips head screwdriver (not included).

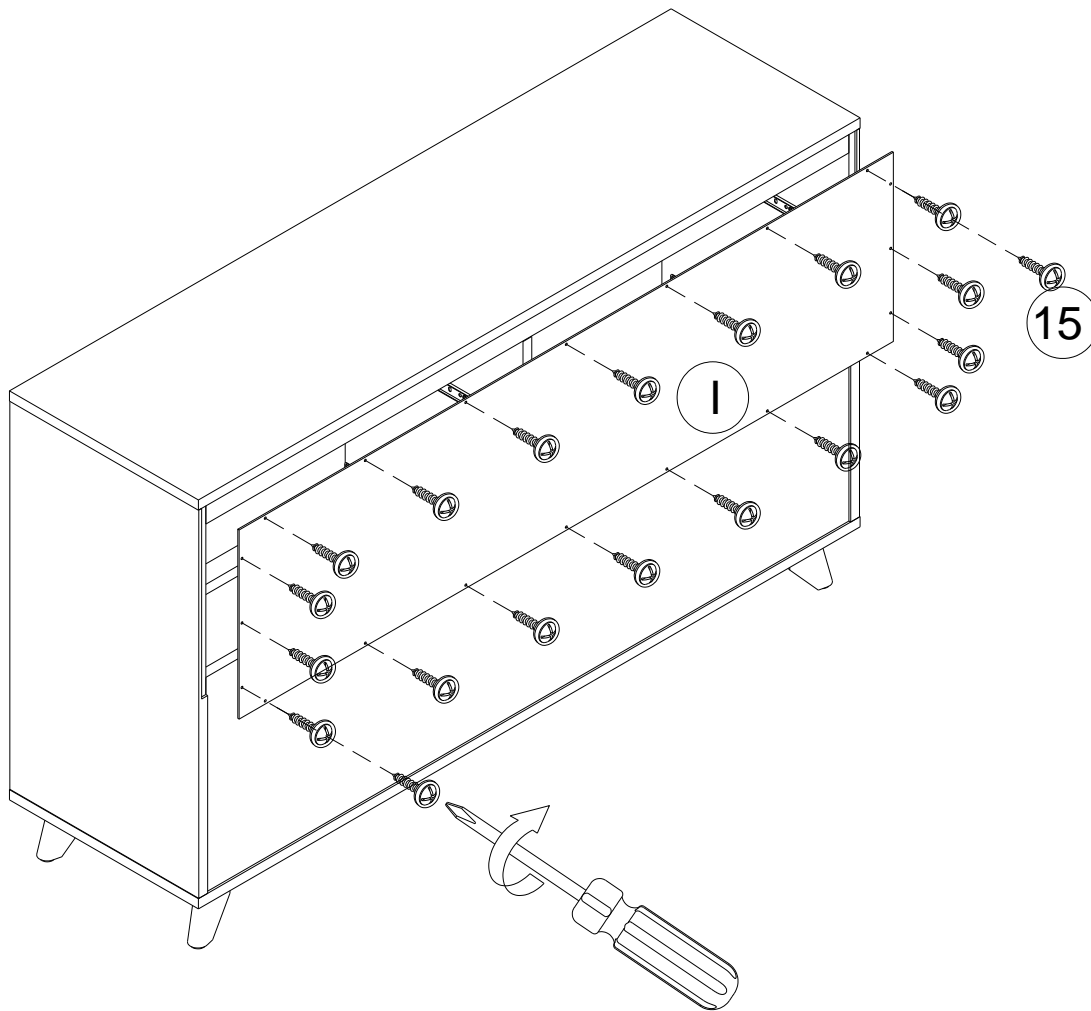

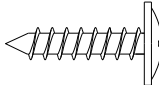
15		20 PCS
----	--	--------

DRESSER

DL8417-1

STEP 9

Insert cam bolts (4) into the drawer fronts (K, L, M & N) as shown.

Insert wood dowels (6) and cam locks (5) into the drawer left and right sides (O & P) as shown. Secure the drawer sides (O & P) to drawer fronts (K, L, M & N) by rotating the cam locks (5) 1/2 turn clockwise using a Phillips head screwdriver (not included).

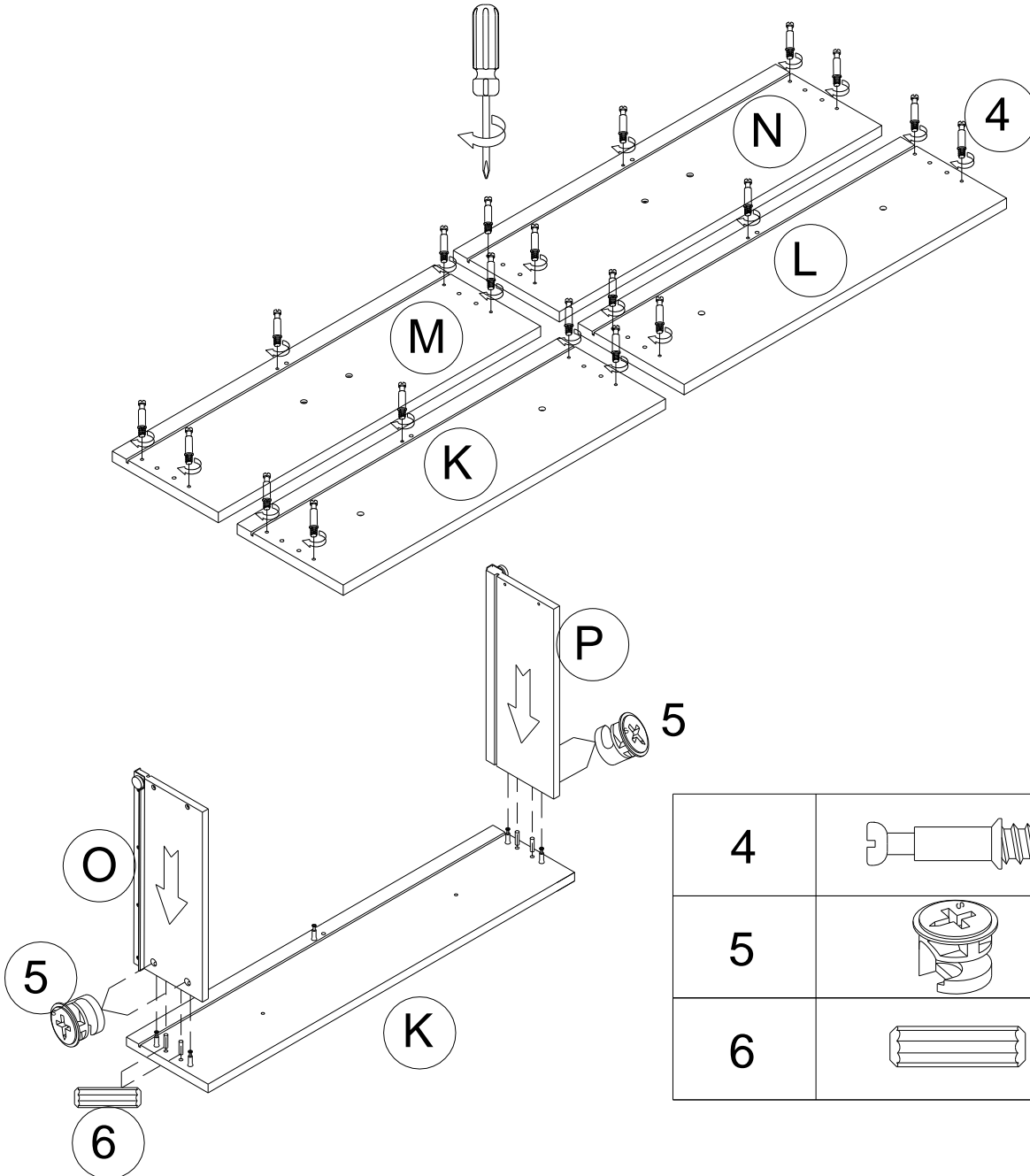

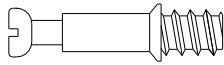
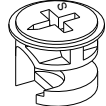
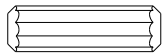
4		30 PCS
5		24 PCS
6		24 PCS



DRESSER DL8417-1

STEP 10

Slide the drawer bottom (R) into the grooves of drawer left & right sides and drawer front.

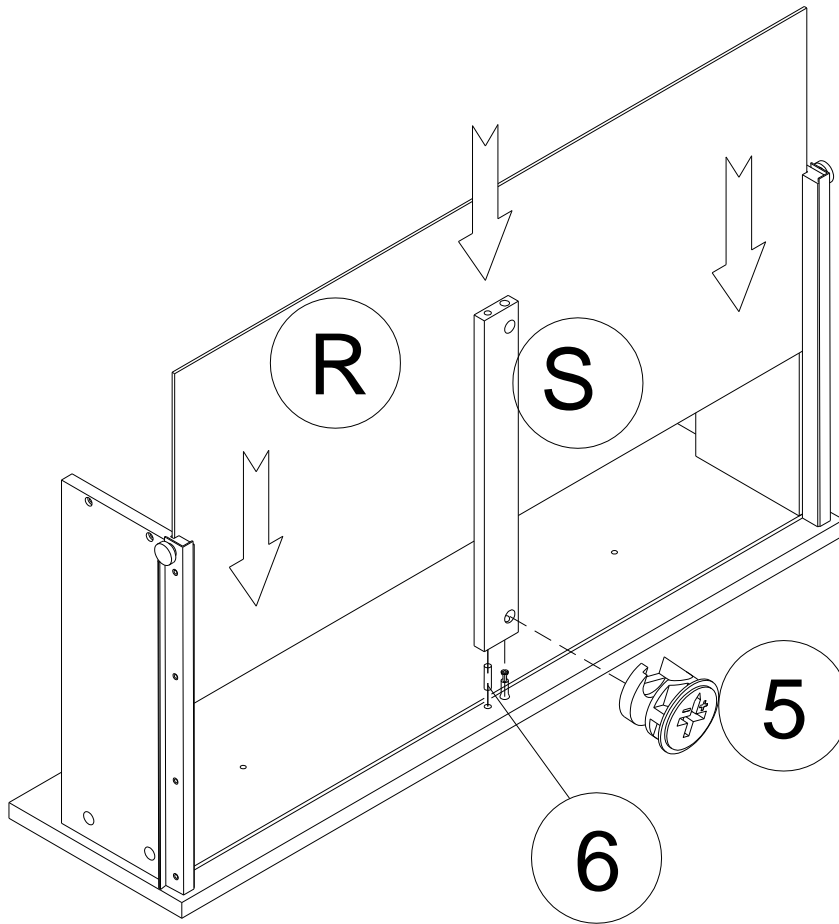
Insert wood dowel (6) and cam lock (5) into the drawer bottom rail (S) as shown. Secure drawer bottom rail (S) to drawer front by rotating the cam lock (5) 1/2 turn clockwise using a Phillips head screwdriver (not included).

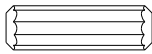

6		6 PCS
5		6 PCS

DRESSER DL8417-1

STEP 11





Insert cam bolt (4) into drawer back (Q) as shown in figure 2.

Insert wood dowel (6) and cam lock (5) into the drawer bottom rail (S) as shown.

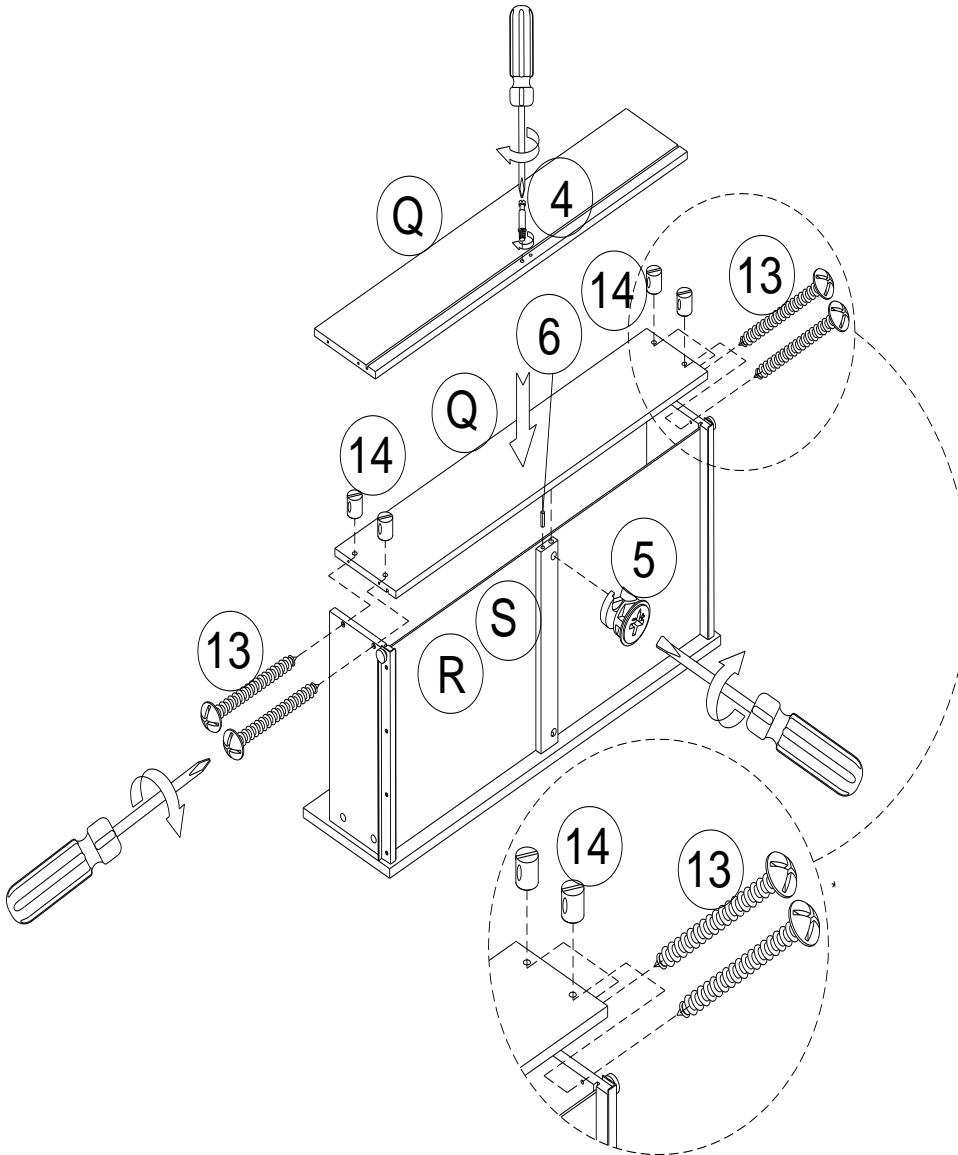
Attach drawer back (Q) to the drawer sides with screws (13) and plastic barrel nuts (14). Secure drawer bottom rail (S) to drawer back (Q) by rotating the cam lock (5) 1/2 turn clockwise using a Phillips head screwdriver (not included).

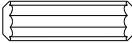
Repeat above steps for other drawers.

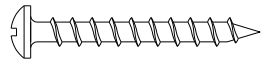

6		6 PCS			
5		6 PCS	14		24 PCS
4		6 PCS	13		24 PCS

DRESSER



DL8417-1

STEP 12

Attach knobs (10) and handles (11) with bolts (9) using a Phillips head screwdriver (not included).

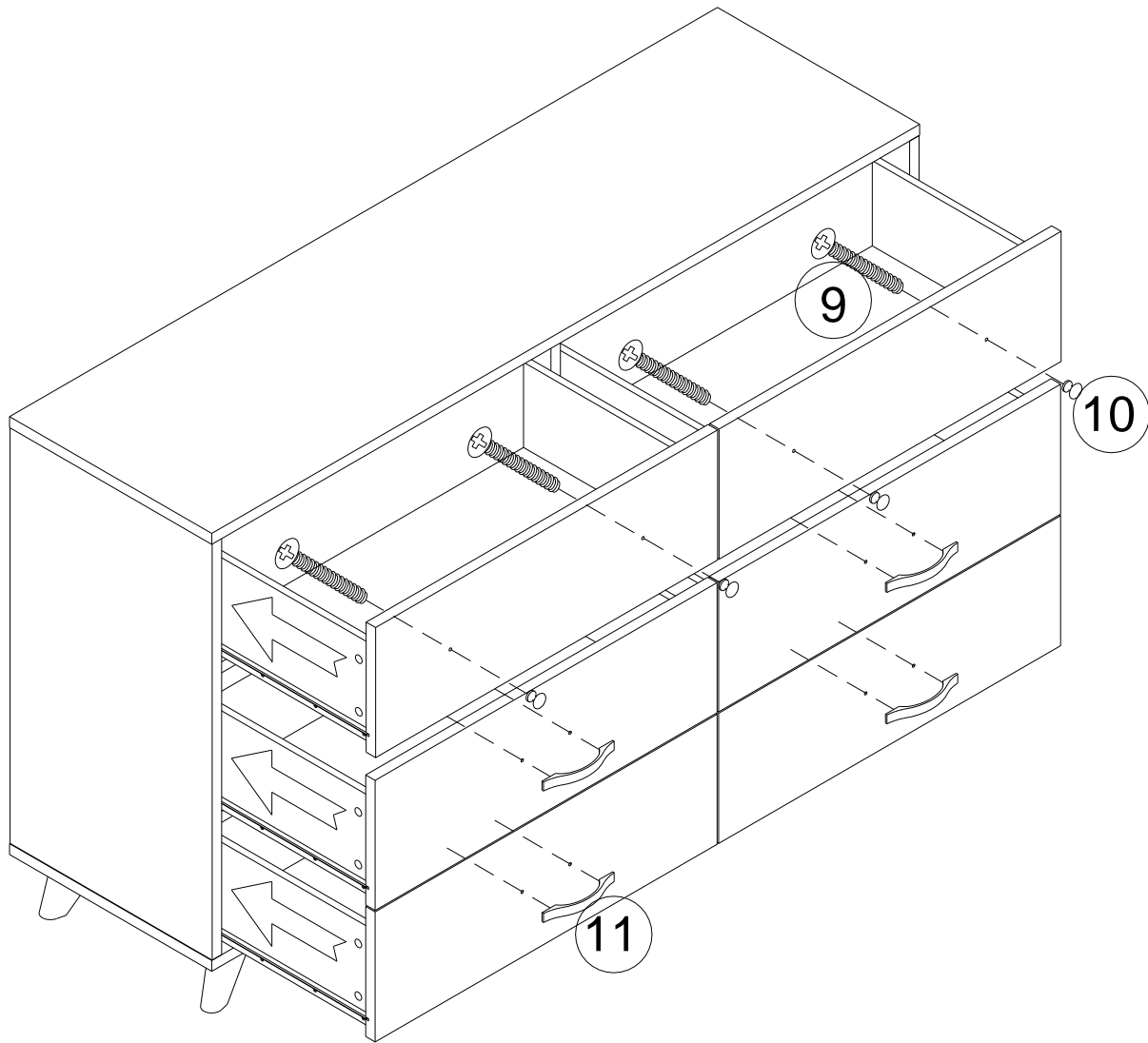
Insert all drawers into the assembled unit.

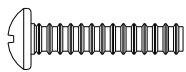

11		4 PCS
10		4 PCS
9		12 PCS

DRESSER

DL8417-1



CAUTION: This unit is intended for use only with the products and/or maximum weights indicated. Use with other products and/or products heavier than the maximum weights indicated may result in instability or cause possible injury.

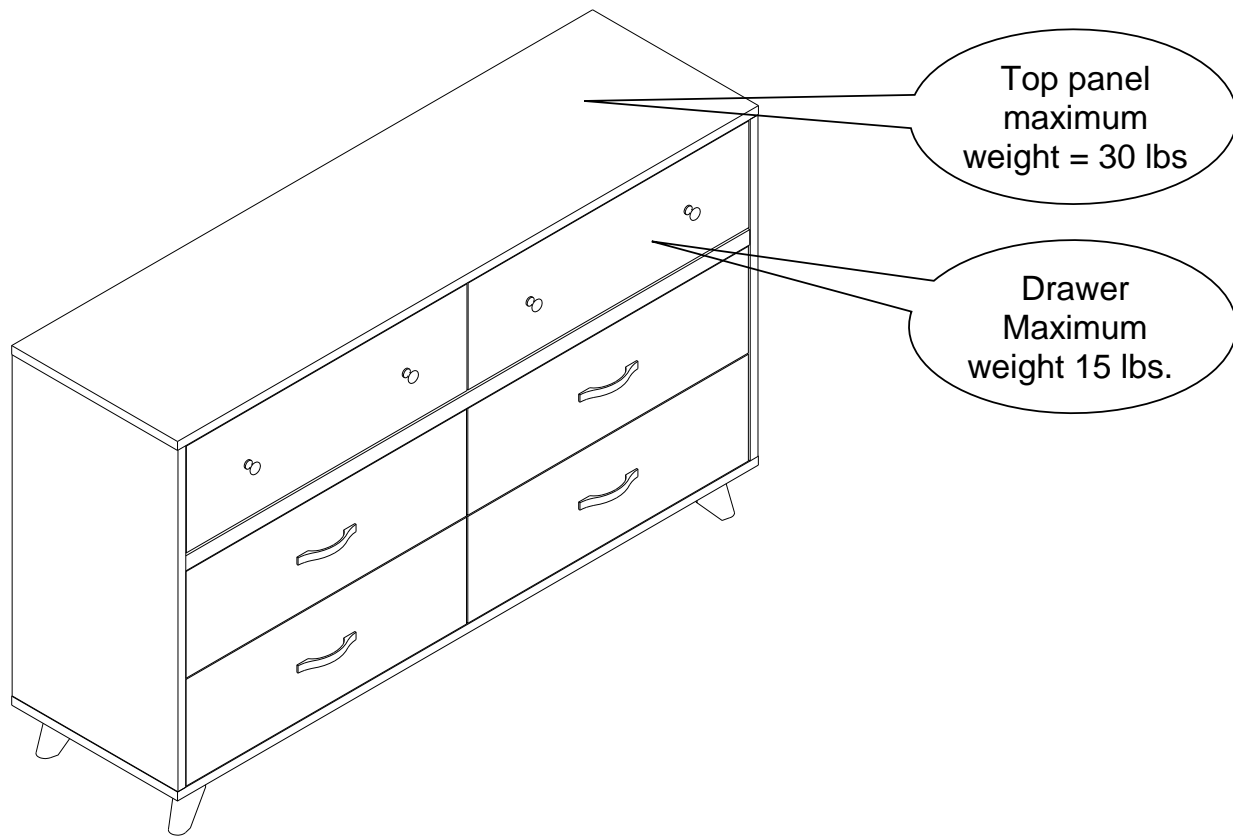

That's it! You've finished assembling your Dresser





DO NOT RETURN PRODUCT TO THE RETAILER

If a part is missing or damaged, contact our customer service department. We will replace the part **FREE** of charge.

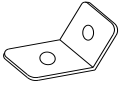

Tel #: 1-800-295-1980
E-Mail: das@dorel.com

Furniture Wall Safety Strap

<p>A</p> 	<p>B</p> 	<p>C</p> 	<p>D</p> 
<p>MOUNTING BRACKET 4 PCS</p>	<p>SAFETY WALL STRAP 2 PCS</p>	<p>LONG SCREW 2 PCS</p>	<p>SHORT SCREW 2 PCS</p>

TOOLS NECESSARY: RUBBER Mallet AND PHILLIPS SCREW DRIVER ARE NOT INCLUDED.

NOTE: 3/8" DRILL BIT AND ELECTRIC DRILL ARE NOT PROVIDED.

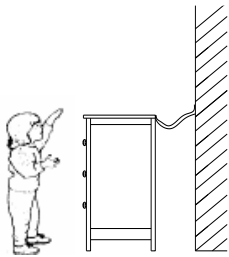

WARNING: WHEN UPRIGHT, IT IS POSSIBLE THAT THE FURNITURE MAY TIP OVER. PLEASE INSTALL THE SAFETY WALL STRAP BEHIND THE FURNITURE TO ENSURE SAFETY.

PLEASE READ ALL INSTRUCTIONS CAREFULLY BEFORE USING THIS PRODUCT AND KEEP THESE INSTRUCTIONS FOR FUTURE REFERENCE. IF YOU HAVE ANY QUESTIONS, PLEASE CALL OUR CUSTOMER SERVICE NUMBER: 1-800-295-1980.

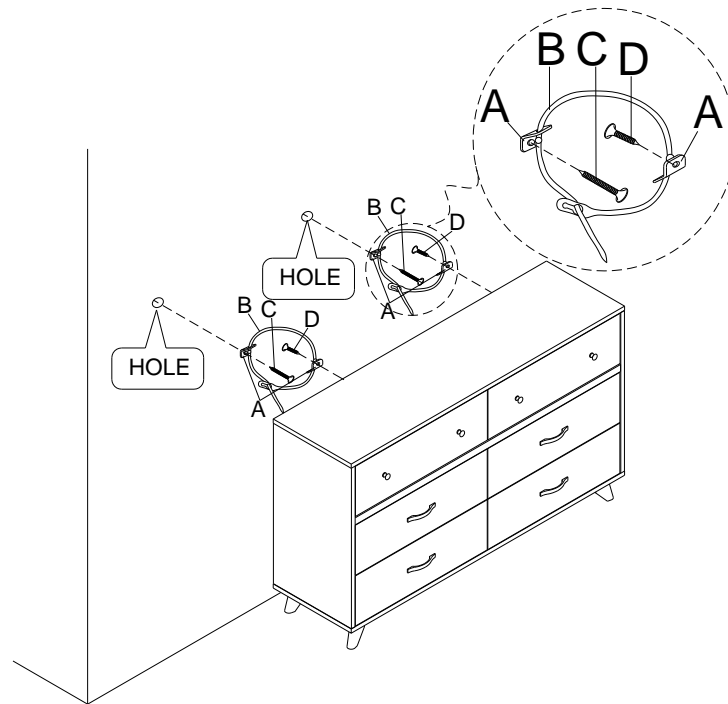

- Step 1:** ATTACH A MOUNTING BRACKET (A) SECURELY TO THE BACK EDGE OF THE FURNITURE USING THE SHORT SCREW (D), THROUGH THE SMALLER HOLE.
- Step 2:** LOCATE THE OTHER MOUNTING BRACKET (A) ON THE WALL OVER A WALL STUD AND 2 INCHES BELOW THE MOUNTING BRACKET SECURED TO THE BACK OF YOUR UNIT. ATTACH TO THE WALL STUD USING THE LONG SCREW (C) PROVIDED, THROUGH THE SMALLER HOLE.
- Step 3:** PLACE THE FURNITURE INTO POSITION SO BOTH MOUNTING BRACKETS ARE VERTICALLY IN LINE. LACE THE END OF THE SAFETY WALL STRAP (B) THROUGH THE LARGER HOLE IN EACH MOUNTING BRACKET (A). BRING BOTH ENDS TOGETHER AND SLIDE THE FLAT END THROUGH THE LOCKING END AND DRAW IT THROUGH UNTIL ALL SLACK IS REMOVED.
- Step 4:** CONFIRM THAT THE STRAP IS SECURELY LACED AND LOCKED.
TO MOVE THE FURNITURE AFTER THE SAFETY WALL STRAP HAS BEEN INSTALLED, SIMPLY REMOVE THE SCREW FROM THE WALL TO LOOSEN THE SAFETY WALL STRAP.

MANUAL DE INSTRUCCIONES

Modelo No:
DL8417-1

CÓMODA

CODIGO UPC
0-65857-19826-3

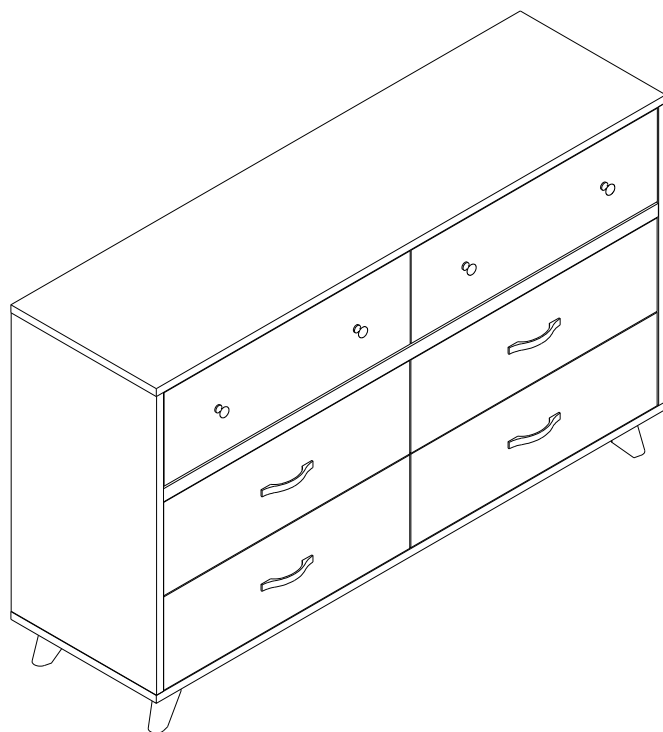

NOTA:
ESTE MANUAL DE INSTRUCCIONES
CONTIENE INFORMACIÓN DE
SEGURIDAD **IMPORTANTE**. POR
FAVOR LÉALA Y CONSÉRVELA
PARA REFERENCIA FUTURA.

Numero de lote:
(TOMADO DEL CARTON)

Fecha de compra:
____ / ____ / ____

**NOV
OGR
ATZ**

NO DEVUELVA EL PRODUCTO A LA TIENDA.
Si falta una pieza o está dañada, contacte nuestro departamento de
servicio a la clientela. Reemplazaremos la pieza SIN cargo.



Tel #: 1-800-295-1980
Correo electrónico: das@dorel.com

SERVICIO AL CLIENTE

También puede contactarnos escribiendo a la dirección que figura a continuación. Por favor incluya el número de modelo del producto, el color y una descripción detallada de su pregunta.

Dorel Living - Customer Service Department
12345 Albert-Hudon Boulevard, Suite 100
Montreal, Quebec
Canada, H1G 3L1

NOTAS E INSTALACIÓN

- * Antes de comenzar a armarla, asegúrese de identificar todas las piezas y componentes
- * Ensamble sobre una superficie suave, lisa para evitar daños en el acabado del producto.
- * Utilice la correa de seguridad provista para fijar el mueble a la pared.
- * El destornillador en cruz no está incluido.
- * **NO USE** herramientas eléctricas.
- * **PRECAUCIÓN:** Requiere ser armado por un adulto.
- * El armado y la manipulación pueden requerir dos personas.
- * Para evitar dañar la superficie, una vez instalados los niveladores, **NO** arrastrar el mueble para desplazarlo. Asegúrese de levantarlo
- * El tiempo de armado se estima en 60 minutos.

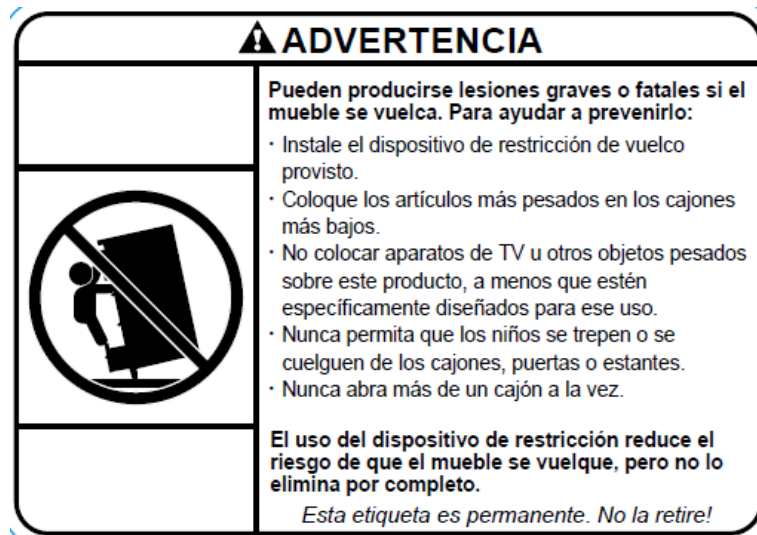

CUIDADO, LIMPIEZA Y MANTENIMIENTO

Límpiala regularmente con un paño suave para evitar la acumulación de suciedad. Ocasionalmente se puede usar un paño húmedo para limpiar la superficie. Séquela inmediatamente. No utilice productos abrasivos que puedan dañar la terminación. Una exposición excesiva a la luz del sol y a cambios extremos de temperatura y humedad puede dañar los muebles de madera. Verifique las arandelas/tornillos periódicamente y ajústelos si es necesario.

GARANTÍA LIMITADA DE 1 AÑO

Dorel garantiza que este producto está libre de defectos de material y mano de obra y se compromete a remediar cualquier defecto de este tipo. Esta garantía cubre 1 año a partir de la fecha de compra original. Esta garantía es válida solamente con presentación de una prueba de compra. Esto se limita a la reparación o reemplazo de componentes defectuosos del mueble y no se incluye ningún trabajo de ensamblaje. Esta garantía no se aplica a ningún producto que haya sido mal ensamblado, sujeto a mal uso o abuso, o que haya sido alterado o reparado de cualquier manera. Cualquier uso, rotura o pérdida de color de la tela no están incluidos en esta garantía (donde corresponda). Esta garantía le da derechos legales específicas y usted puede también tener otros derechos que varían de estado a estado o de provincia a provincia.







ADVERTENCIA: Si este producto está dañado y/o ciertas piezas faltan o están rotas, NO LO USE.

CÓMODA

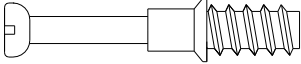
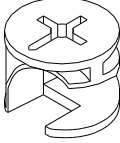
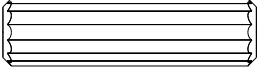
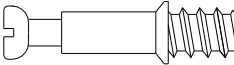
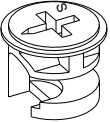
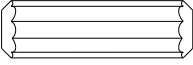
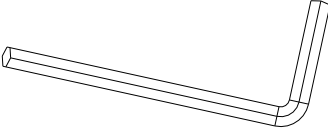
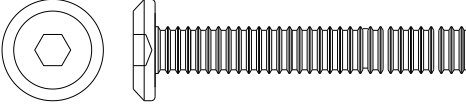
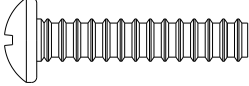
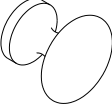
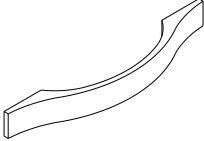
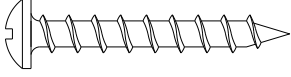
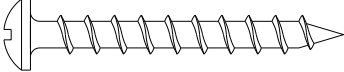
DL8417-1

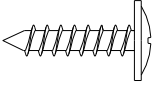
LISTA DE ACCESORIOS

1		2		3	 Ø8 X 30mm
PERNO DE LEVA 22 PCS		SEGURO DE LEVA 22 PCS		CLAVIJA DE MADERA 30 PCS	
4		5		6	 Ø6 X 20mm
PERNO DE LEVA 36 PCS		SEGURO DE LEVA 36 PCS		CLAVIJA DE MADERA 36 PCS	
7		8			
LLAVE ALLEN 1 PC		 Ø1/4" X 40mm			
PERNO 21 PCS					
9	 Ø9 X 4 X 20mm	10		11	
PERNO 12 PCS		POMO 4 PCS		MANIJA 4 PCS	
12	 Ø8 X 4 X 30mm	13	 Ø8 X 4 X 35mm	14	 Ø8 X 8mm
TORNILLO 4 PCS		TORNILLO 24 PCS		TUERCA BARRILETE DE PLÁSTICO 24 PCS	
15	 M3 X 15mm	16			
TORNILLO 20 PCS		CORREA DE SEGURIDAD 2 PAQUETES			

CÓMODA DL8417-1

LISTA DE PIEZAS

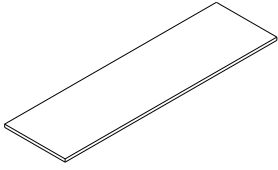
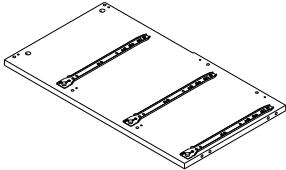
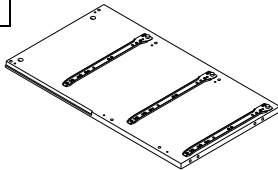
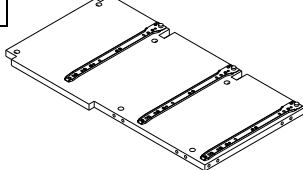
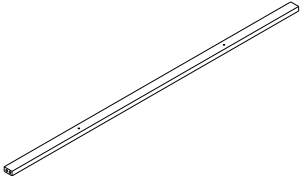
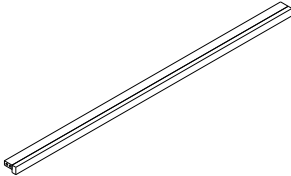
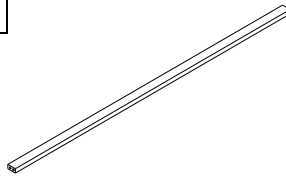
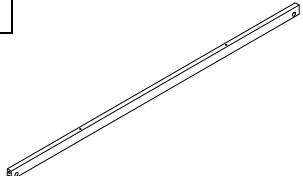
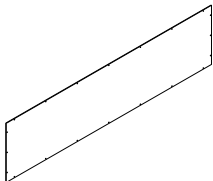
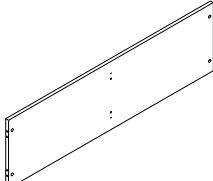
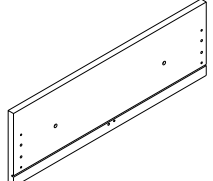
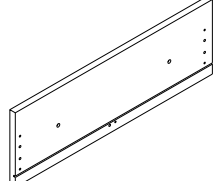
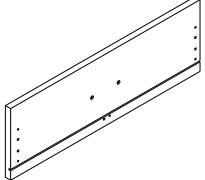
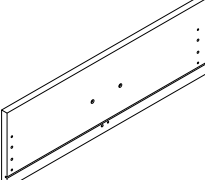
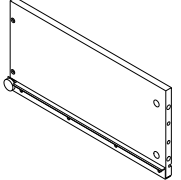
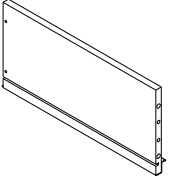
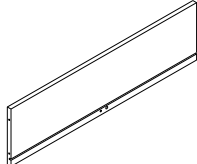
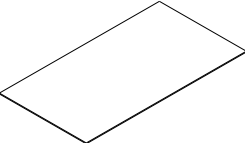
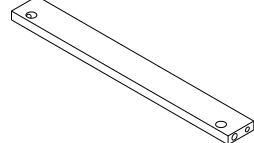
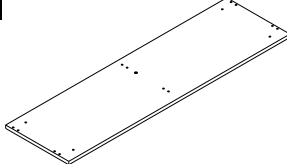
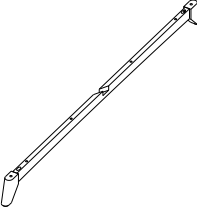
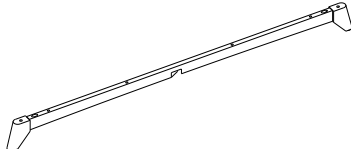
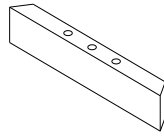
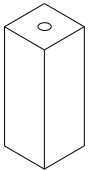
<p>A</p> 	<p>B</p> 	<p>C</p> 	<p>D</p> 
<p>TAPA DE LA CÓMODA 1 PC</p>	<p>PANEL LATERAL IZQUIERDO 1 PC</p>	<p>PANEL LATERAL DERECHO 1 PC</p>	<p>PANEL CENTRAL 1 PC</p>
<p>E</p> 	<p>F</p> 	<p>G</p> 	<p>H</p> 
<p>BARRA SUPERIOR ANTERIOR 1 PC</p>	<p>BARRA CENTRAL ANTERIOR 1 PC</p>	<p>BARRA INFERIOR ANTERIOR 1 PC</p>	<p>BARRA SUPERIOR POSTERIOR 1 PC</p>
<p>I</p> 	<p>J</p> 	<p>K</p> 	<p>L</p> 
<p>PANEL SUPERIOR POSTERIOR 1 PC</p>	<p>PANEL INFERIOR POSTERIOR 1 PC</p>	<p>FRENTE CAJÓN SUPERIOR IZQUIERDO 1 PC</p>	<p>FRENTE CAJÓN SUPERIOR DERECHO 1 PC</p>
<p>M</p> 	<p>N</p> 	<p>O</p> 	<p>P</p> 
<p>FRENTE CAJÓN INFERIOR IZQUIERDO 2 PCS</p>	<p>FRENTE CAJÓN INFERIOR DERECHO 2 PCS</p>	<p>LADO IZQUIERDO CAJÓN 6 PCS</p>	<p>LADO DERECHO CAJÓN 6 PCS</p>
<p>Q</p> 	<p>R</p> 	<p>S</p> 	<p>T</p> 
<p>LADO POSTERIOR CAJÓN 6 PCS</p>	<p>FONDO CAJÓN 6 PCS</p>	<p>BARRA INFERIOR CAJÓN 6 PCS</p>	<p>PANEL INFERIOR 1 PC</p>
<p>U</p> 	<p>V</p> 	<p>W</p> 	<p>Y</p> 
<p>BARRA INFERIOR BASE 1 PC</p>	<p>BARRA SUPERIOR BASE 1 PC</p>	<p>BARRA TRANSVERSAL 2 PCS</p>	<p>PATA DE SOPORTE 1 PC</p>

CÓMODA DL8417-1

ETAPA 1

Inserte pernos de leva (1) en los paneles lateral izquierdo y derecho (B y C) con un destornillador Phillips (no incluido), como ilustrado.

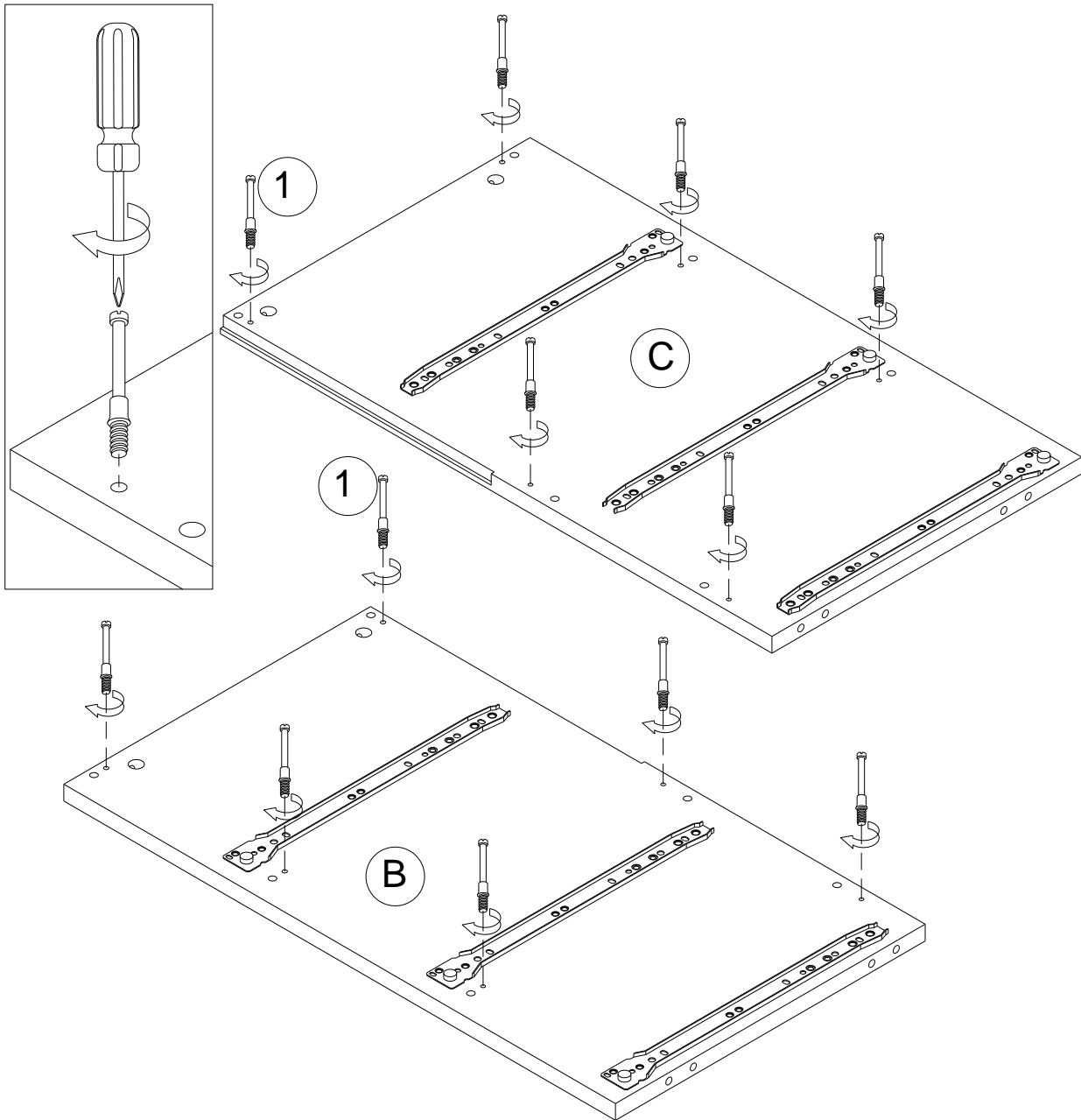

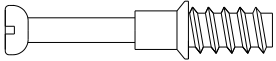
1		12 PCS
---	---	--------

CÓMODA DL8417-1

ETAPA 2

Inserte pernos de leva (1) en el panel inferior posterior (J), en la barra central anterior (F) y en la barra inferior anterior (G) con un destornillador Phillips (no incluido), como ilustrado.

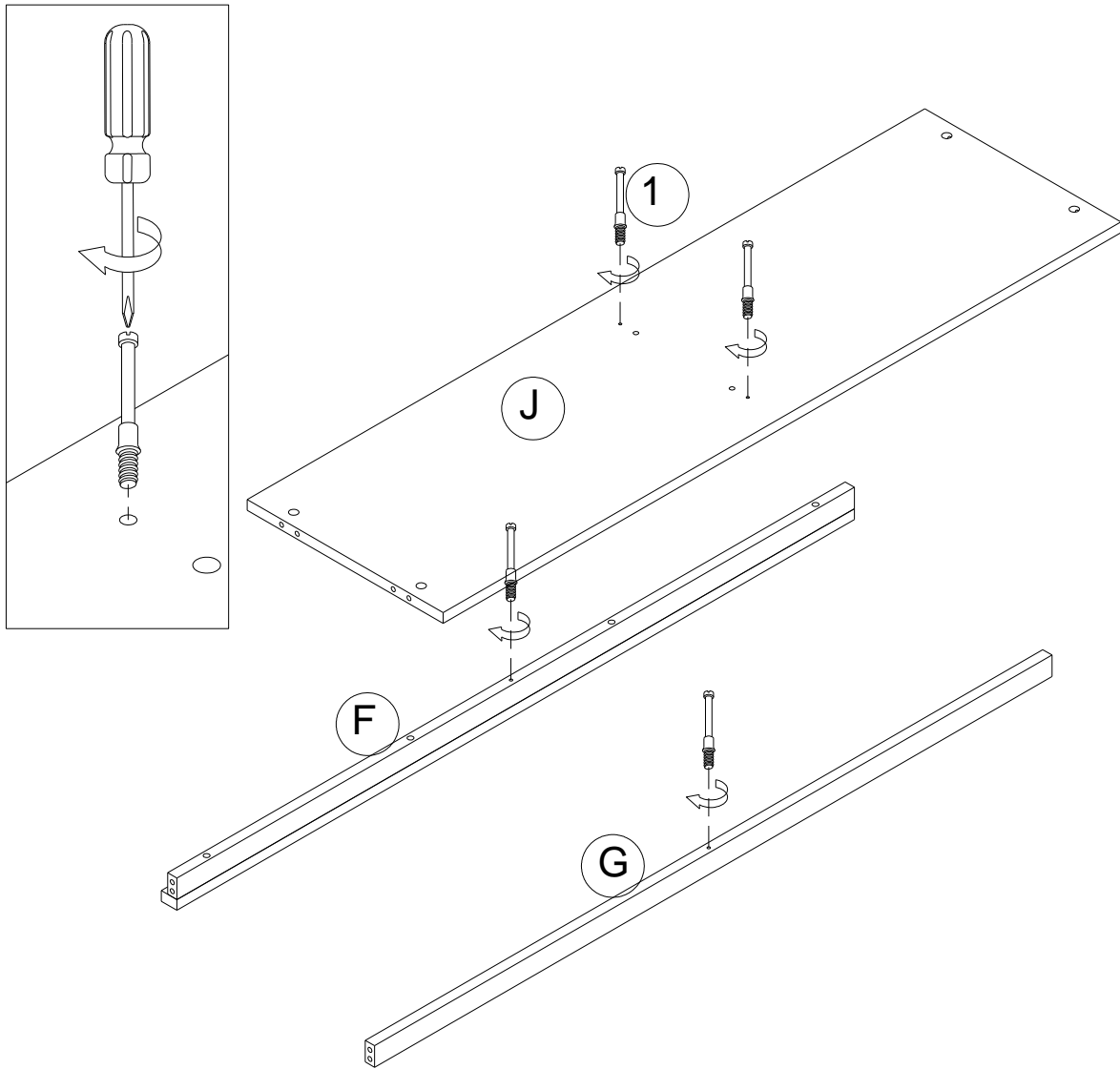

1		4 PCS
---	--	-------

CÓMODA DL8417-1

ETAPA 3

Inserte clavijas de madera (3) y seguros de leva (2) en el panel central (D) como ilustrado.
Fije el panel central (D) al panel inferior posterior (J) girando los seguros de leva 1/2 vuelta en sentido horario con un destornillador Phillips (no incluido).

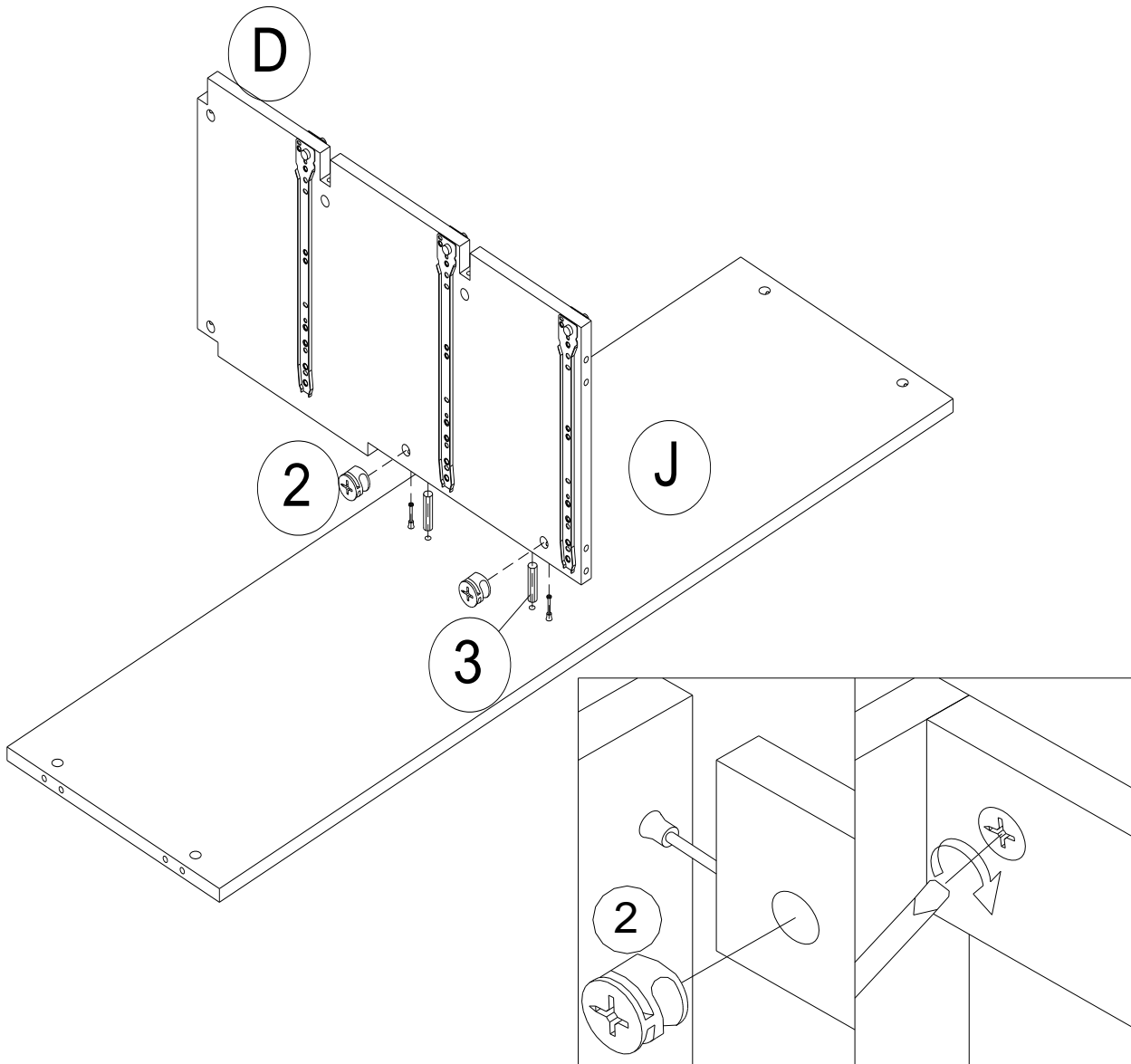

2		2 PCS
3		2 PCS

CÓMODA DL8417-1

ETAPA 4

Inserte seguros de leva (2) y clavijas de madera (3) en las barras (E, F, G y H), en el panel inferior posterior (J) y en los paneles laterales (B y C) como ilustrado.

Conecte las barras (E, F, G y H) al panel central (D) como ilustrado.

Fije las barras (E, F, G y H) al panel central (D) girando los seguros de leva (2) 1/2 vuelta en sentido horario con un destornillador Philip (no incluido).

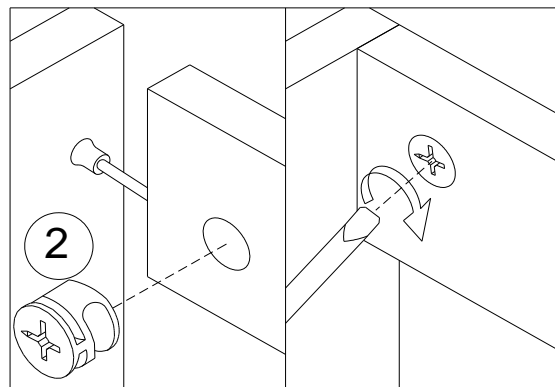
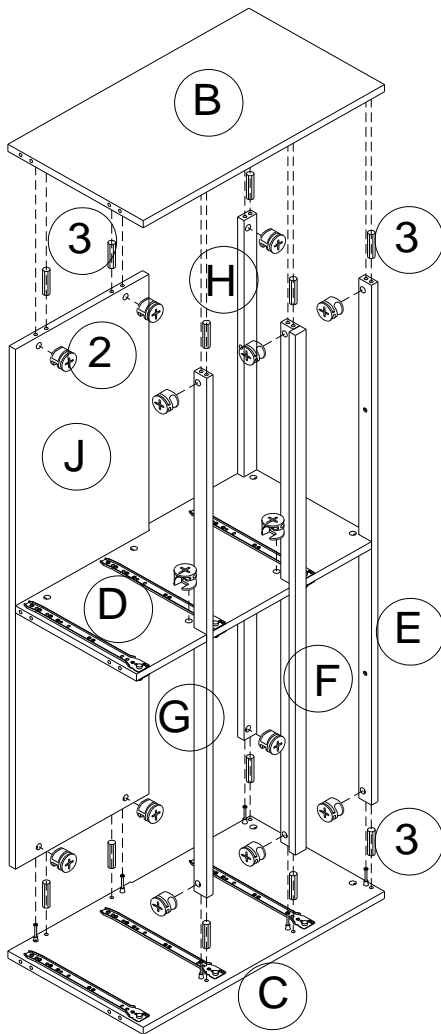

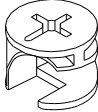
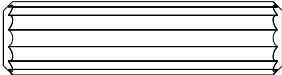
2		14 PCS
3		12 PCS

CÓMODA DL8417-1

ETAPA 5

Inserte clavijas de madera (3) en el panel inferior (T).

Una las barras transversales (W), la barra inferior de base (U), la barra superior de base (V) y la pata de soporte (Y) al panel inferior (T) con pernos (8). Utilice la llave Allen (7) para ajustar los pernos.

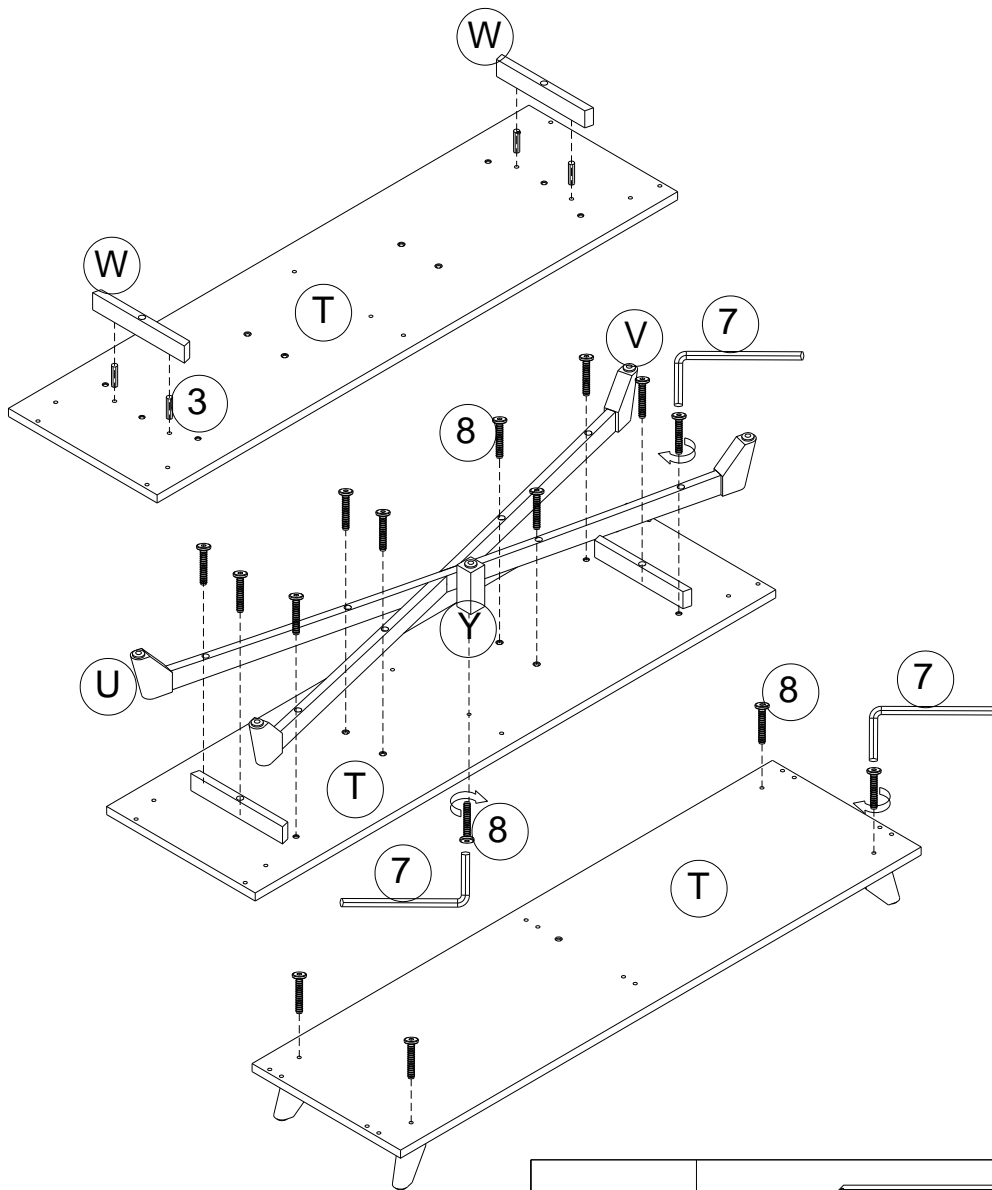

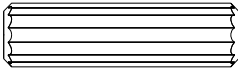
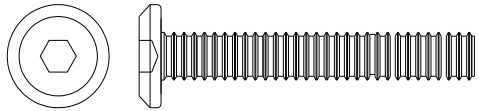
3		4 PCS
8		15 PCS

CÓMODA DL8417-1

ETAPA 6

Inserte clavijas de madera (3) en el panel inferior (T). Una el panel inferior (T) a los paneles laterales (B y C) y al panel central (D) con pernos (8). Utilice la llave Allen (7) para ajustar los pernos.

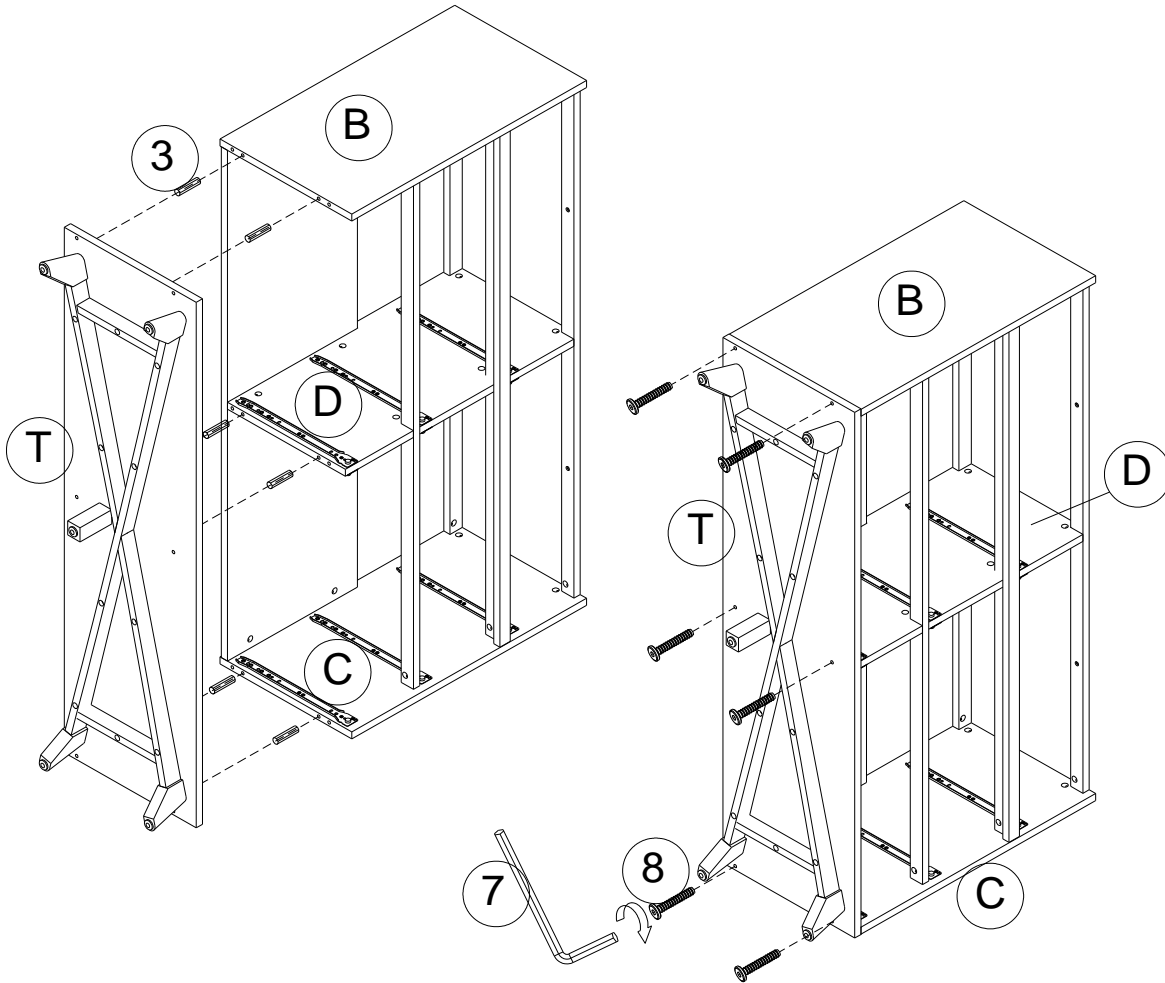

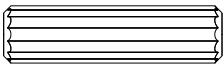
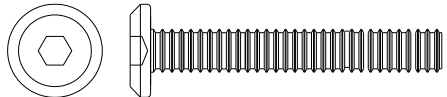
3		6 PCS
8		6 PCS

CÓMODA DL8417-1

ETAPA 7

Inserte pernos de leva (1) en la tapa de cómoda (A).

Inserte seguros de leva (2) y clavijas de madera (3) en los paneles laterales (B y C) y en el panel central (D) como ilustrado.

Una la tapa de la cómoda (A) con la unidad ensamblada y fijela girando los seguros de leva (2) 1/2 vuelta en sentido horario con un destornillador Phillips (no incluido).

Fije bien la tapa de la cómoda (A) con la unidad ensamblada con tornillos (12) y un destornillador Phillips (no incluido).

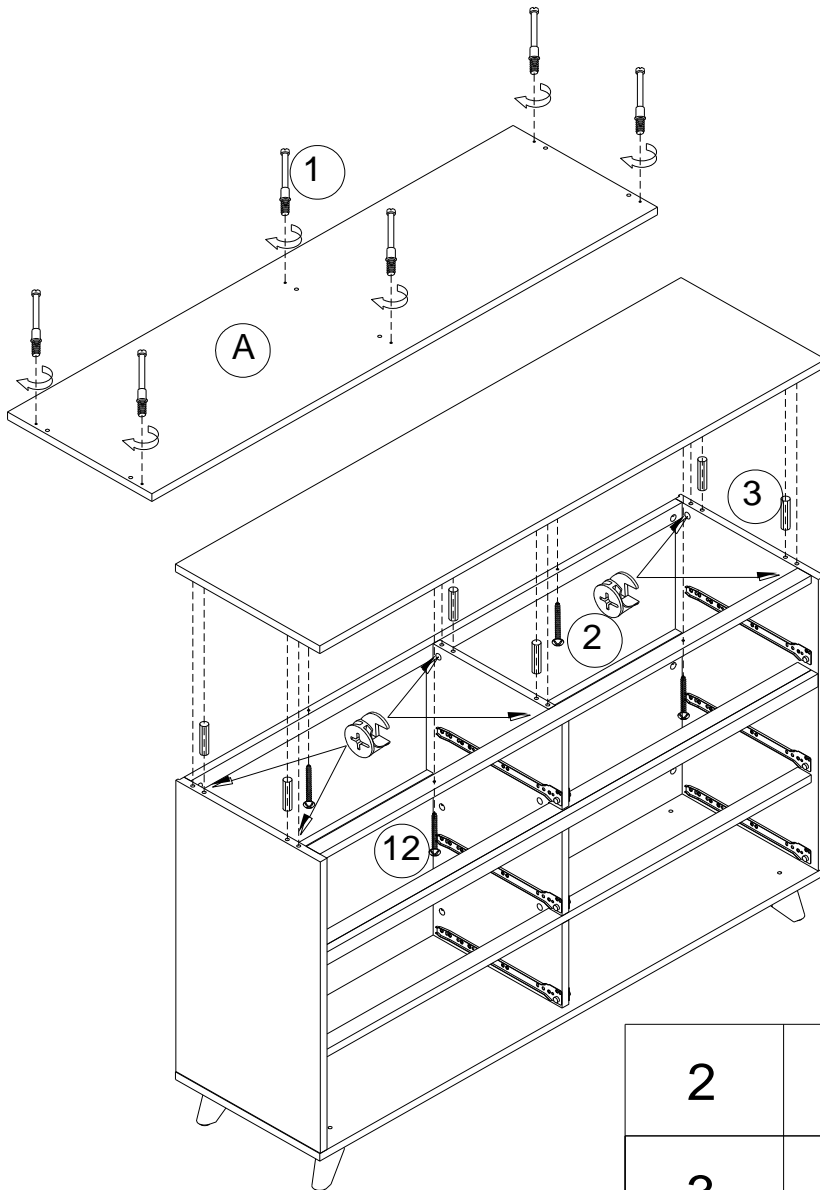

1		6 PCS	2		6 PCS
			3		6 PCS
			12		4 PCS

CÓMODA DL8417-1

ETAPA 8

Una el panel superior posterior (I) a la unidad ensamblada con tornillos (15) y un destornillador Phillips (no incluido).

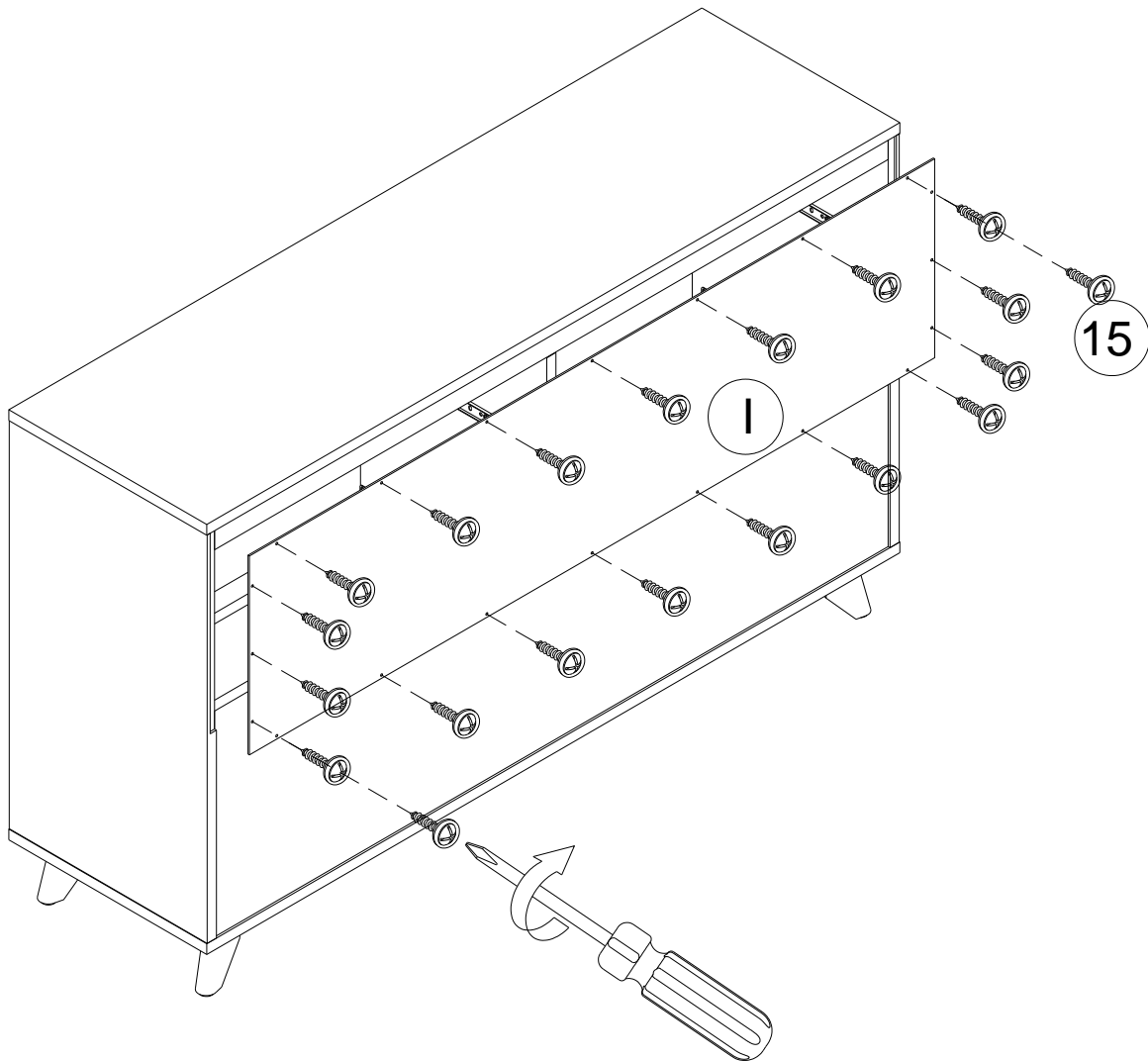

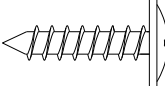
15		20 PCS
----	--	--------

CÓMODA DL8417-1

ETAPA 9

Inserte pernos de leva (4) en los frentes de los cajones (K, L, M y N) como ilustrado.
 Inserte clavijas de madera (6) y seguros de leva (5) en los lados izquierdo y derecho de los cajones (O y P) como ilustrado.
 Fije los lados de los cajones (O y P) a los frentes de los cajones (K, L, M y N) girando los seguros de leva (5) 1/2 vuelta en sentido horario con un destornillador Phillips (no incluido).

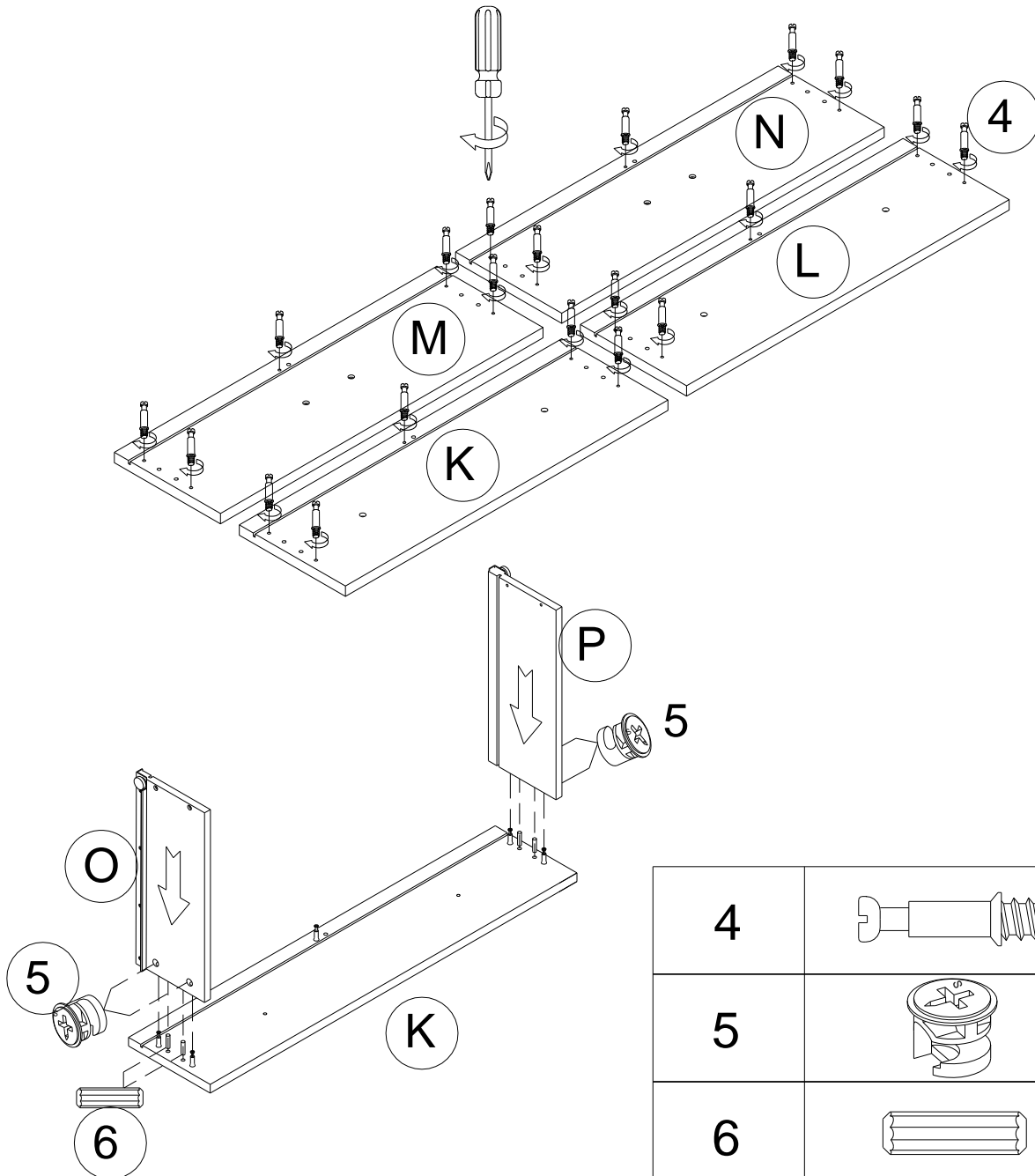

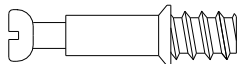
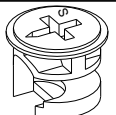
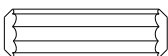
4		30 PCS
5		24 PCS
6		24 PCS

CÓMODA DL8417-1

ETAPA 10

Deslice el fondo del cajón (R) en las ranuras de los lados izquierdo y derecho del cajón y del frente del cajón.

Inserte una clavija de madera (6) y un seguro de leva (5) en la barra inferior del cajón (S) como ilustrado.

Fije la barra inferior del cajón (S) al frente del cajón girando el seguro de leva (5) 1/2 vuelta en sentido horario con un destornillador Phillips (no incluido).

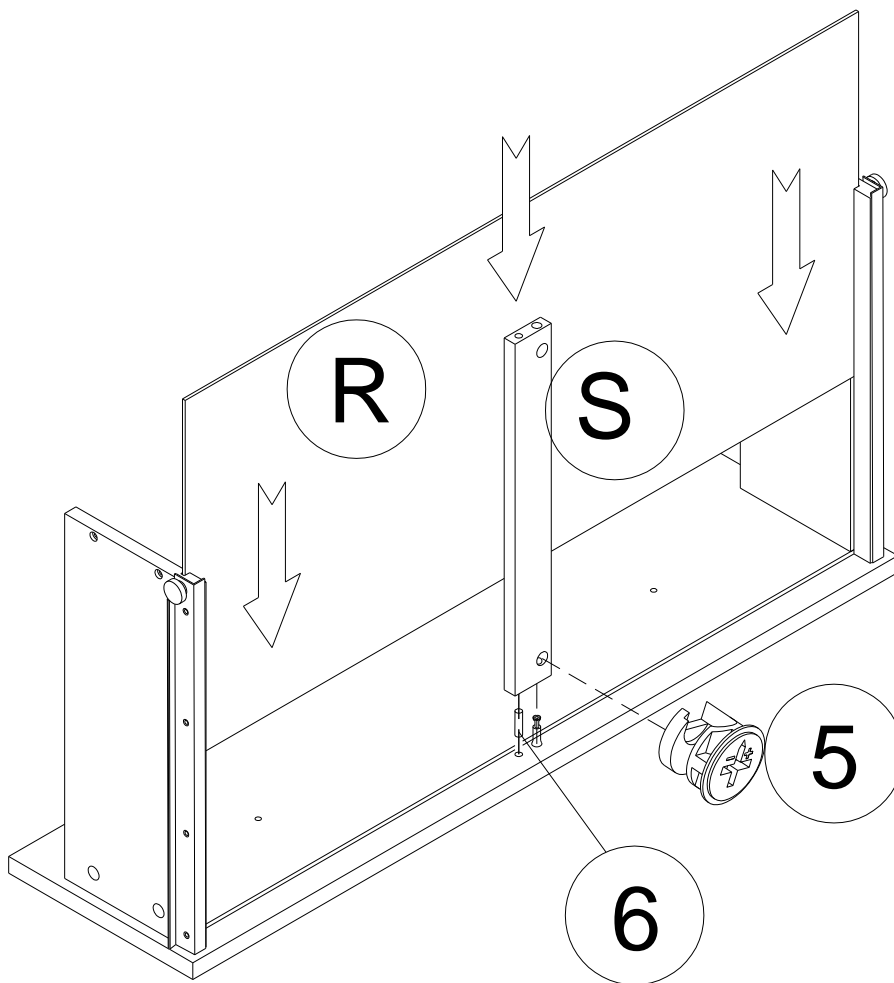

6		6 PCS
5		6 PCS

CÓMODA DL8417-1

ETAPA 11

Inserte un perno de leva (4) en el lado posterior del cajón (Q) como ilustrado en la figura 2. Inserte una clavija de madera (6) y un seguro de leva (5) en la barra inferior del cajón (S) como ilustrado.

Una el lado posterior del cajón (Q) a los lados del cajón con tornillos (13) y tuercas barrilete de plástico (14). Fije la barra inferior del cajón (S) al lado posterior del cajón (Q) girando el seguro de leva (5) 1/2 vuelta en sentido horario con un destornillador Phillips (no incluido).

Repita las etapas anteriores para ensamblar los otros cajones.

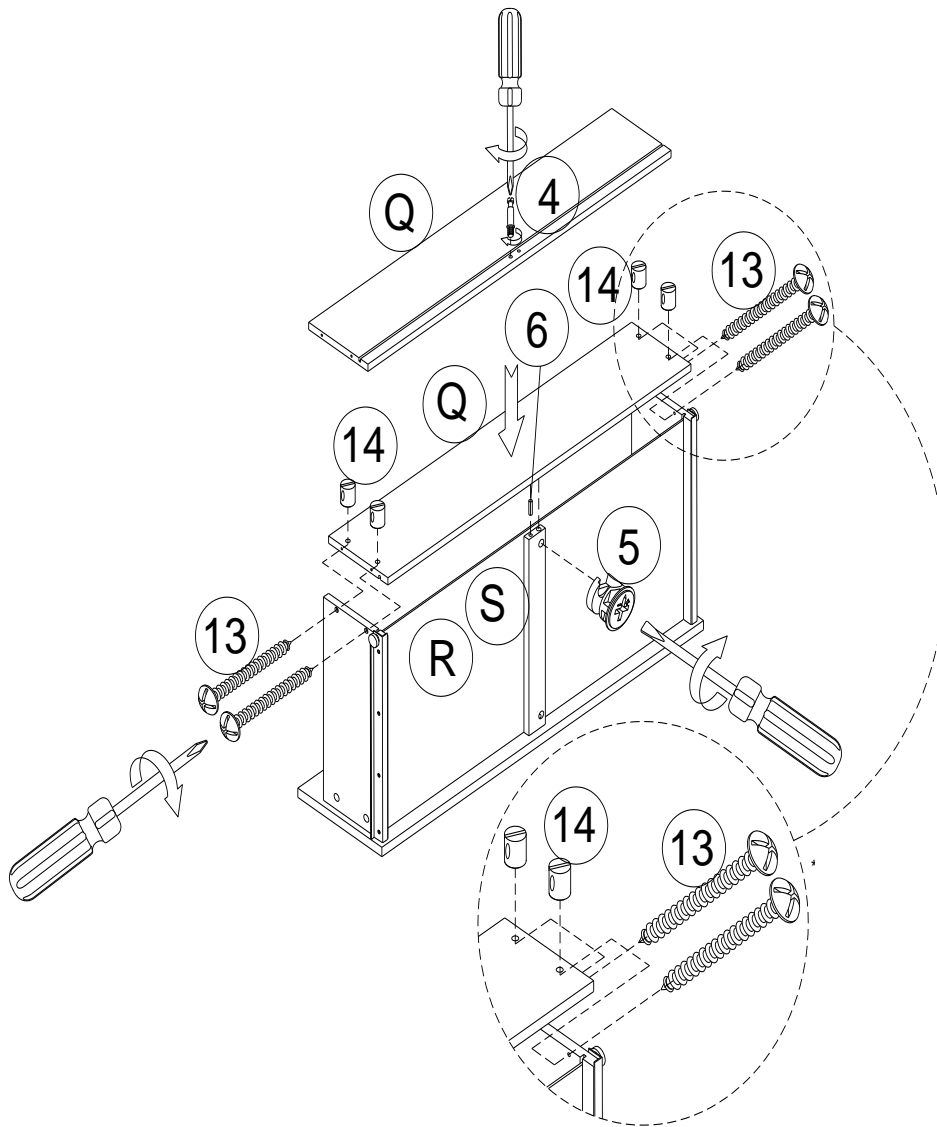

6		6 PCS			
5		6 PCS	14		24 PCS
4		6 PCS	13		24 PCS



CÓMODA DL8417-1

ETAPA 12

Coloque los pomos (10) y las manijas (11) con pernos (9) y un destornillador Phillips (no incluido).

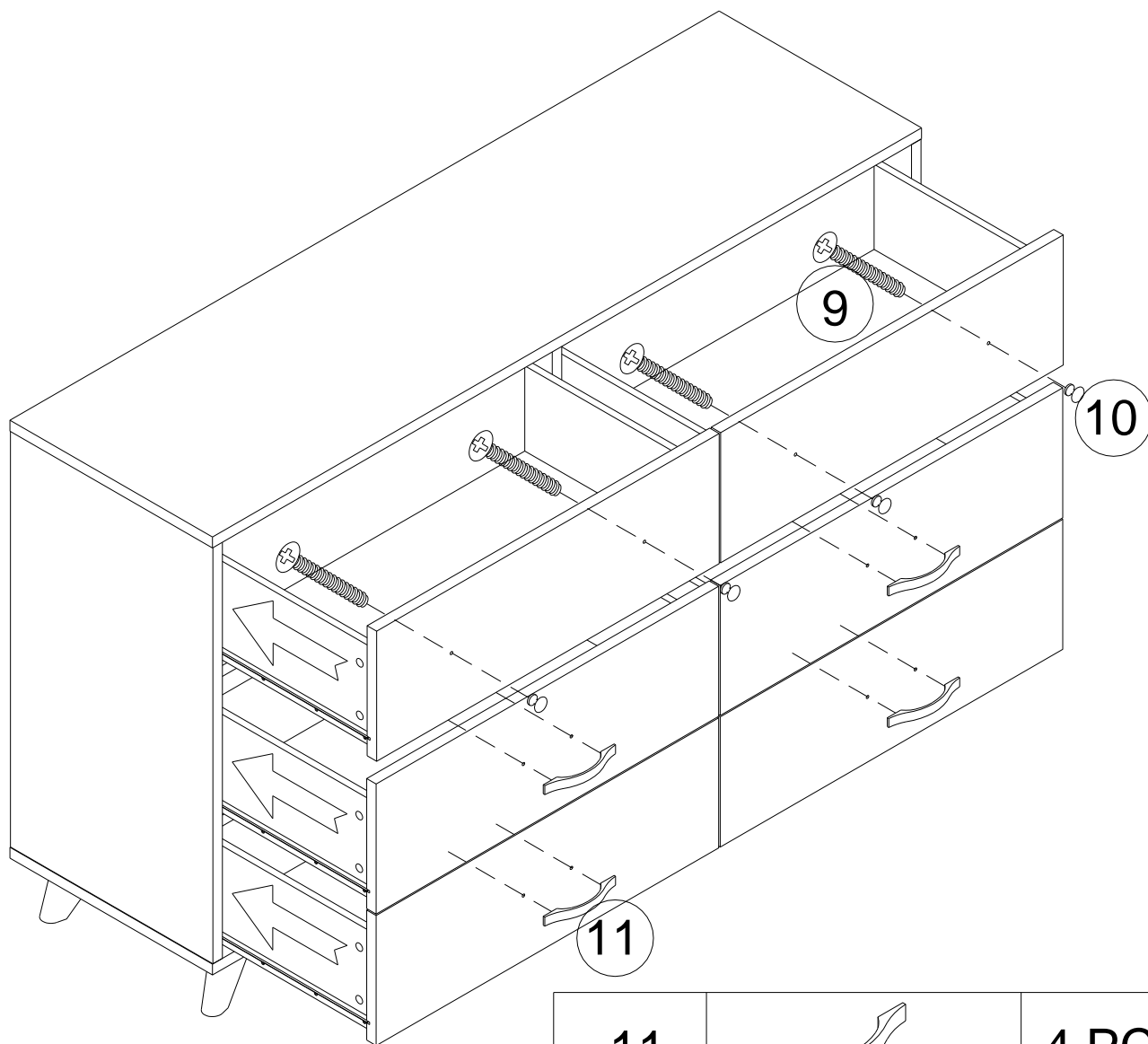
Coloque todos los cajones en la cómoda ensamblada.

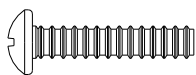

11		4 PCS
10		4 PCS
9		12 PCS

CÓMODA DL8417-1

! **PRECAUCIÓN:** Esta unidad está prevista únicamente para ser usada con los productos y el peso máximo indicados. El usarla con otros productos más pesados que el peso máximo indicado puede provocar inestabilidad y causar heridas.

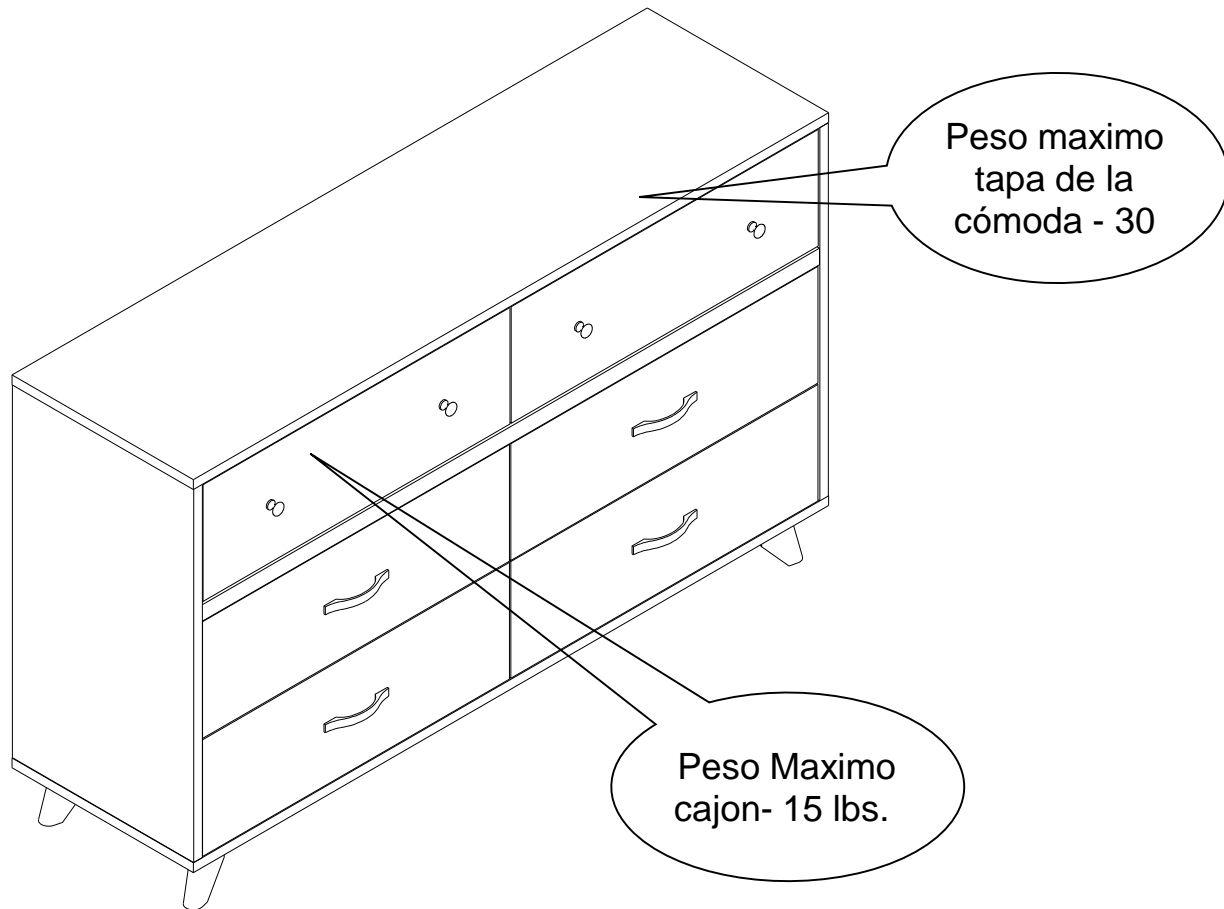

¡Listo! Has terminado de armar su cómoda..

NO DEVUELVA EL PRODUCTO A LA TIENDA

Si falta una pieza o está dañada, contacte nuestro departamento de servicio a la cliente
Reemplazaremos la pieza **SIN NINGÚN** cargo



Tel #: 1-800-295-19
Correo electrónico: das@dorel.com

Correa de seguridad para fijar el mueble a la pared

A	B	C	D
GANCHO DE METAL 4 PZAS	CORREA DE SEGURIDAD PARA LA PARED- 1 PZA	TORNILLO LARGO 2 PZAS	TORNILLO CORTO 2PZAS

HERRAMIENTAS NECESARIAS: LA MASA DE CAUCHO Y EL DESTORNILLADOR PHILLIPS NO ESTÁN

NOTA: LA MECHA DE 5/16" Y EL TALADRO ELÉCTRICO NO ESTÁN INCLUIDOS.

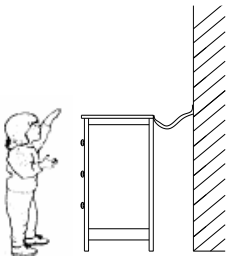

ADVERTENCIA: ES POSIBLE QUE EL MUEBLE PUEDA VOLCARSE AL ESTAR DE PIE. INSTALE LA CORREA DE SEGURIDAD PARA LA PARED DETRÁS DEL MUEBLE PARA ASEGURARSE DE QUE NO SE VUELQUE.

SÍRVASE LEER TODAS LAS INSTRUCCIONES CON ATENCIÓN ANTES DE UTILIZAR ESTE PRODUCTO Y SÍRVASE CONSERVARLAS PARA SU USO FUTURO. SI TIENE PREGUNTAS, POR FAVOR LLAME A NUESTRO NÚMERO DE ATENCIÓN AL CLIENTE:
1-800-295-1980.

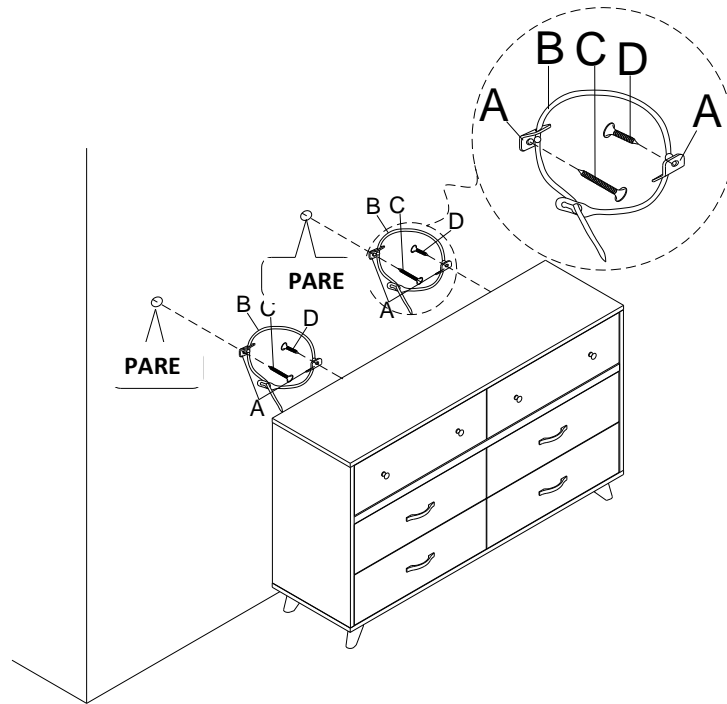

- Etapa 1:** CON EL TORNILLO CORTO (A), FIJE FIRMEMENTE UN GANCHO DE METAL (D) A LA BARRA TRANSVERSAL SUPERIOR POSTERIOR DEL MUEBLE, A TRAVÉS DEL AGUJERO MÁS PEQUEÑO
- Etapa 2:** CON UN ANCLAJE, COLOQUE EL OTRO GANCHO DE METAL (A) SOBRE LA PARED 2 PULGADAS POR DEBAJO DEL GANCHO YA COLOCADO EN LA PARTE POSTERIOR DEL MUEBLE. FÍJELO AL ANCLAJE DE LA PARED CON EL TORNILLO LARGO (C), A TRAVÉS DEL AGUJERO MÁS PEQUEÑO.
- Etapa 3:** COLOQUE EL MUEBLE EN SU POSICIÓN DE MANERA QUE LOS DOS GANCHOS ESTÉN ALINEADOS VERTICALMENTE. PASE EL EXTREMO DE LA CORREA DE SEGURIDAD (B) A TRAVÉS DEL AGUJERO MÁS GRANDE DE CADA GANCHO (A). COLOQUE LOS DOS EXTREMOS JUNTOS Y DESLICE EL EXTREMO PLANO A TRAVÉS DEL EXTREMO DE LA FIJACIÓN HASTA QUE QUEDE BIEN AJUSTADO.
- Etapa 4:** PARA DESPLAZAR EL MUEBLE DESPUÉS DE HABER INSTALADO LA CORREA EN LA PARED, RETIRE EL TORNILLO DE LA PARED PARA AFLOJAR LA CORREA DE SEGURIDAD.

MANUEL D'INSTRUCTIONS

Modèle No:
DL8417-1

COMMODE



CODE CUP:
0-65857-19826-3

NOTE:
CE LIVRE D'INSTRUCTIONS
CONTIENT DES
INFORMATIONS
IMPORTANTES SUR LA
SÉCURITÉ. S.V.P. LIRE ET
CONSERVER POUR
RÉFÉRENCE ULTÉRIEURE.

Numéro de lot
(SITUE SUR LA BOÎTE)

Date d'achat:

____ / ____ / ____

**NOV
OGR
ATZ**

NE PAS RETOURNER LE PRODUIT AU DÉTAILLANT
Si une pièce est manquante ou endommagée, contactez notre Service
la clientèle. Nous remplacerons la pièce **GRATUITEMENT**!



Tél #: 1-800-295-1999
Courriel: das@dorel.com

SERVICE À LA CLIENTÈLE

Vous pouvez également nous contacter en écrivant à l'adresse ci-dessous. S'il vous plaît inclure le numéro de modèle du produit, la couleur et une description détaillée de votre demande.

Dorel Living - Customer Service Département

12345 Albert-Hudon Boulevard, Suite 100

Montreal, Québec

Canada, H1G 3L1

NOTES ET INSTALLATION

- * Veuillez vous assurer d'avoir toutes les pièces et composantes avant de commencer l'assemblage.
- * Monter sur une surface douce, lisse pour éviter d'endommager la finition du produit.
- * Utilisez la courroie de sécurité fournie pour fixer le meuble au mur.
- * Le tournevis à tête cruciforme n'est pas inclus
- * **NE PAS UTILISER** d'outils électriques.
- * **ATTENTION:** Doit être assemblé par un adulte.
- * Deux personnes peuvent être nécessaires pour l'assemblage et la manipulation.
- * Pour éviter des dommages, une fois les niveleurs installés, **NE PAS** traîner le meuble sur la surface pour le déplacer. Assurez-vous de le soulever.
- * Le temps d'assemblage estimé est de 60 minutes.



SOIN, NETTOYAGE ET ENTRETIEN

Époussetez régulièrement avec un chiffon doux, sans peluche pour empêcher la poussière de s'accumuler. Un chiffon humide peut être utilisé à l'occasion pour nettoyer la surface. Séchez immédiatement. Ne pas utiliser de produits abrasifs qui pourraient endommager la finition. Une exposition excessive au soleil et aux changements extrêmes de température et à l'humidité peuvent endommager les mobiliers en bois.

Vérifiez les boulons/vis périodiquement et serrez-les si nécessaire.

GARANTIE LIMITÉE DE 1 AN

Dorel garantit que son produit est exempt de défauts de matériaux et de fabrication et accepte de remédier à un tel défaut. Cette garantie couvre un (1) an à partir de la date d'achat originale. Cette garantie est valable uniquement sur présentation d'une preuve d'achat. Cette garantie se limite exclusivement à la réparation ou au remplacement de pièces défectueuses du mobilier et aucun travail d'assemblage n'est inclus. Cette garantie ne s'applique pas à un produit qui a été assemblé incorrectement, soumis à une mauvaise utilisation ou abus, ou qui a été modifié ou réparé de quelque façon. L'usure, les déchirures ou la décoloration du tissu ne sont pas couverts par cette garantie (le cas échéant). Cette garantie vous donne des droits légaux spécifiques et vous pouvez également avoir d'autres droits qui varient d'un État à l'autre ou d'une province à l'autre.









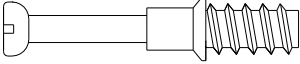
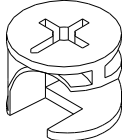
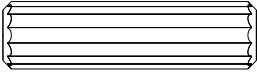
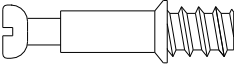

AVERTISSEMENT! Si ce produit est endommagé et/ou des pièces sont brisées ou manquantes, NE PAS UTILISER.

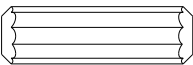
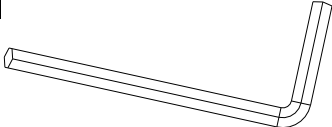
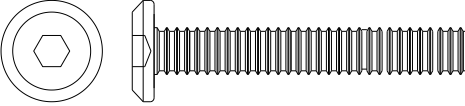
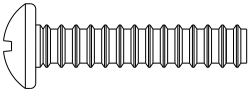
COMMODE

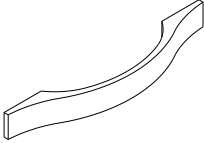
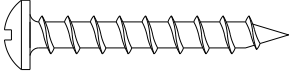
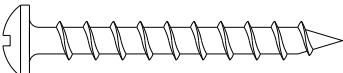
DL8417-1

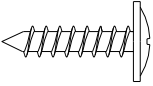
LISTE DE QUINCAILLERIE

<p>1</p> 	<p>2</p> 	<p>3</p>  <p>Ø8 X 30mm</p>
<p>BOULON À CAME 22 PCS</p>	<p>VERROUILLAGE À CAME 22 PCS</p>	<p>GOUJON DE BOIS 30 PCS</p>
<p>4</p> 	<p>5</p> 	<p>6</p>  <p>Ø6 X 20mm</p>
<p>BOULON À CAME 36 PCS</p>	<p>VERROUILLAGE À CAME 36 PCS</p>	<p>GOUJON DE BOIS 36 PCS</p>
<p>7</p> 	<p>8</p>  <p>Ø1/4" X 40mm</p>	
<p>CLÉ ALLEN 1 PC</p>	<p>BOULON 21 PCS</p>	
<p>9</p>  <p>Ø9 X 4 X 20mm</p>	<p>10</p> 	<p>11</p> 
<p>BOULON 12 PCS</p>	<p>BOUTON 4 PCS</p>	<p>POIGNÉE 4 PCS</p>
<p>12</p>  <p>Ø8 X 4 X 30mm</p>	<p>13</p>  <p>Ø8 X 4 X 35mm</p>	<p>14</p>  <p>Ø8 X 8mm</p>
<p>VIS 4 PCS</p>	<p>VIS 24 PCS</p>	<p>ÉCROU TRANSVERSAL DE PLASTIQUE - 24 PCS</p>
<p>15</p>  <p>M3 X 15mm</p>	<p>16</p> 	
<p>VIS 20 PCS</p>	<p>COURROIE DE SÉCURITÉ 2 PAQUETS</p>	

COMMODE

DL8417-1

LISTE DE PIÈCES

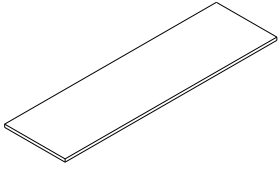
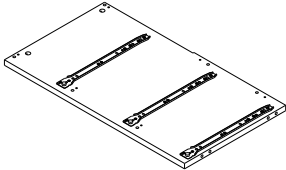
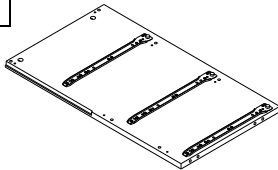
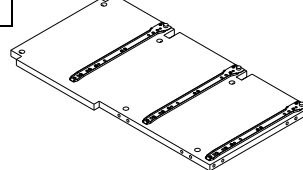
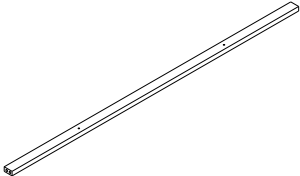
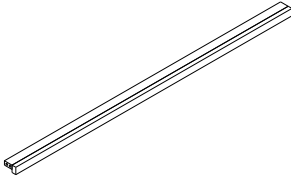
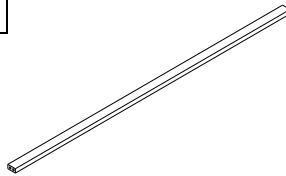
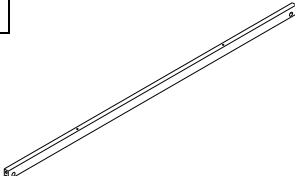
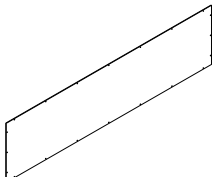
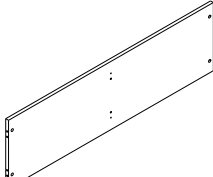
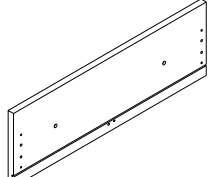
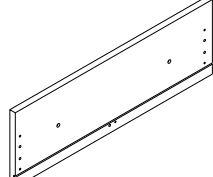
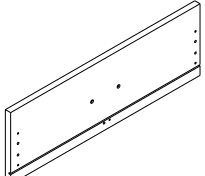
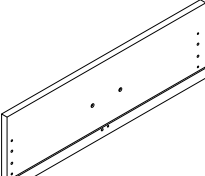
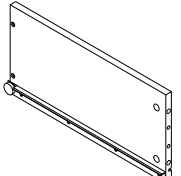
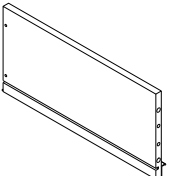
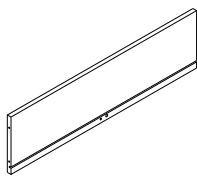
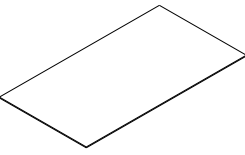
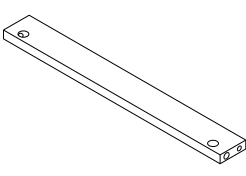
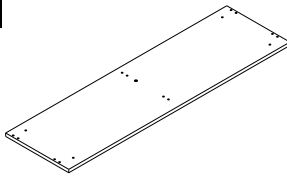
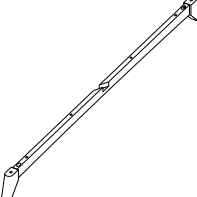
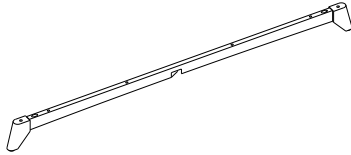
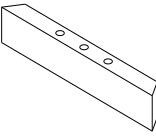
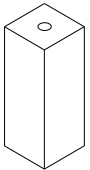
<p>A</p> 	<p>B</p> 	<p>C</p> 	<p>D</p> 
<p>DESSUS DE COMMODE 1 PC</p>	<p>PANNEAU LATÉRAL GAUCHE 1 PC</p>	<p>PANNEAU LATÉRAL DROIT 1 PC</p>	<p>PANNEAU CENTRAL 1 PC</p>
<p>E</p> 	<p>F</p> 	<p>G</p> 	<p>H</p> 
<p>BARRE SUPÉRIEURE AVANT 1 PC</p>	<p>BARRE CENTRALE AVANT 1 PC</p>	<p>BARRE INFÉRIEURE AVANT 1 PC</p>	<p>BARRE SUPÉRIEURE ARRIÈRE 1 PC</p>
<p>I</p> 	<p>J</p> 	<p>K</p> 	<p>L</p> 
<p>PANNEAU SUPÉRIEUR ARRIÈRE 1 PC</p>	<p>PANNEAU INFÉRIEUR ARRIÈRE 1 PC</p>	<p>DEVANT TIROIR SUPÉRIEUR GAUCHE 1 PC</p>	<p>DEVANT TIROIR SUPÉRIEUR DROIT 1 PC</p>
<p>M</p> 	<p>N</p> 	<p>O</p> 	<p>P</p> 
<p>DEVANT TIROIR INFÉRIEUR GAUCHE 2 PCS</p>	<p>DEVANT TIROIR INFÉRIEUR DROIT 2 PCS</p>	<p>CÔTÉ GAUCHE TIROIR 6 PCS</p>	<p>CÔTÉ DROIT TIROIR 6 PCS</p>
<p>Q</p> 	<p>R</p> 	<p>S</p> 	<p>T</p> 
<p>CÔTÉ ARRIÈRE TIROIR 6 PCS</p>	<p>FOND DE TIROIR 6 PCS</p>	<p>BARRE INFÉRIEURE TIROIR 6 PCS</p>	<p>PANNEAU INFÉRIEUR 1 PC</p>
<p>U</p> 	<p>V</p> 	<p>W</p> 	<p>Y</p> 
<p>BARRE INFÉRIEURE BASE 1 PC</p>	<p>BARRE SUPÉRIEURE BASE 1 PC</p>	<p>BARRE TRANSVERSALE 2 PCS</p>	<p>PIED DE SUPPORT 1 PC</p>

COMMODE DL8417-1

ÉTAPE 1

Insérez des boulons à came (1) dans les panneaux latéraux gauche et droit (B et C) à l'aide d'un tournevis cruciforme (non compris) tel qu'illustré.

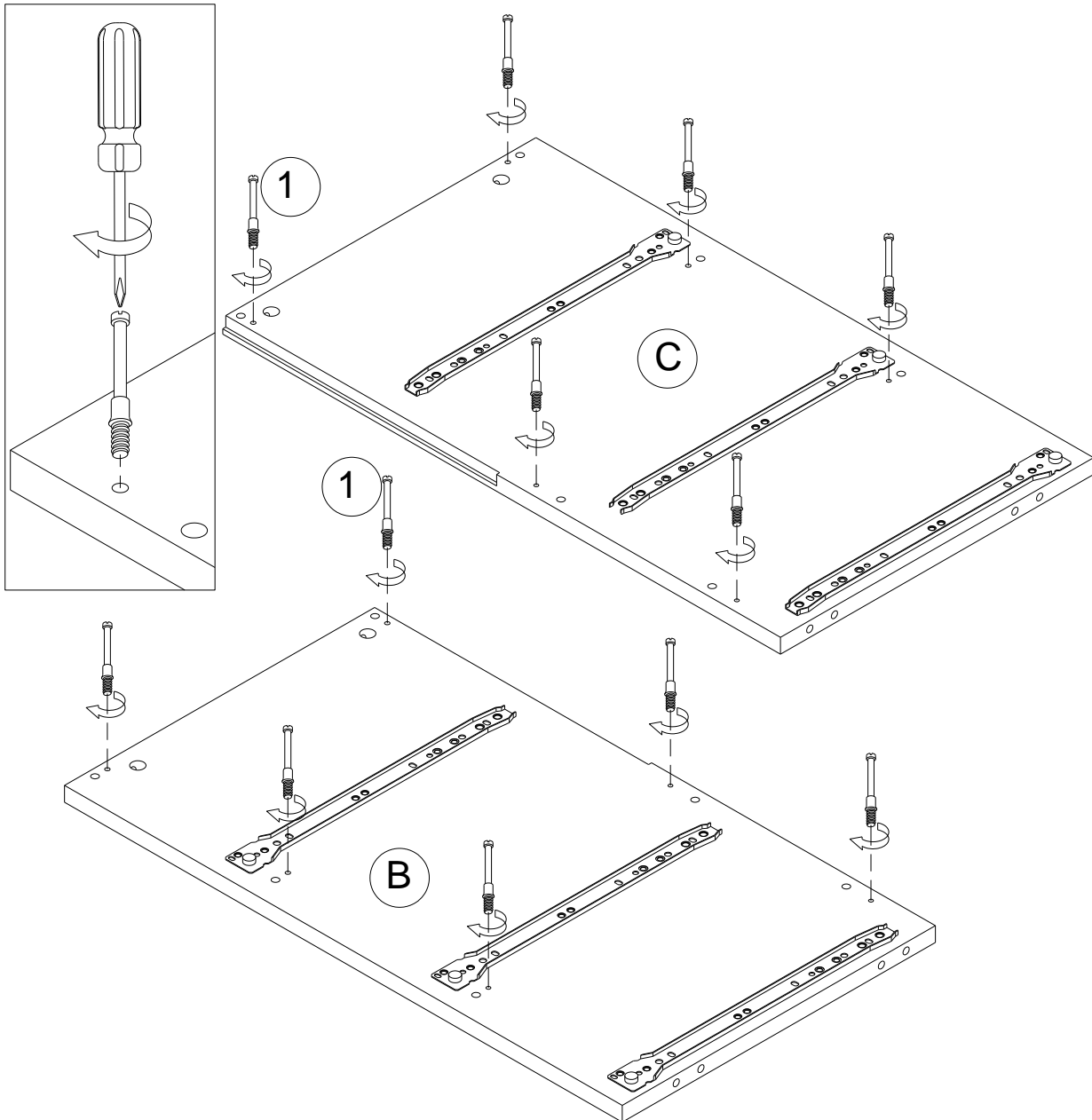

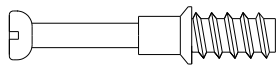
1		12 PCS
---	--	--------

COMMODE

DL8417-1

ÉTAPE 2

Insérez des boulons à came (1) dans le panneau inférieur arrière (J), dans la barre centrale avant (F) et dans la barre inférieure avant (G) à l'aide d'un tournevis cruciforme (non compris) tel qu'illustré.

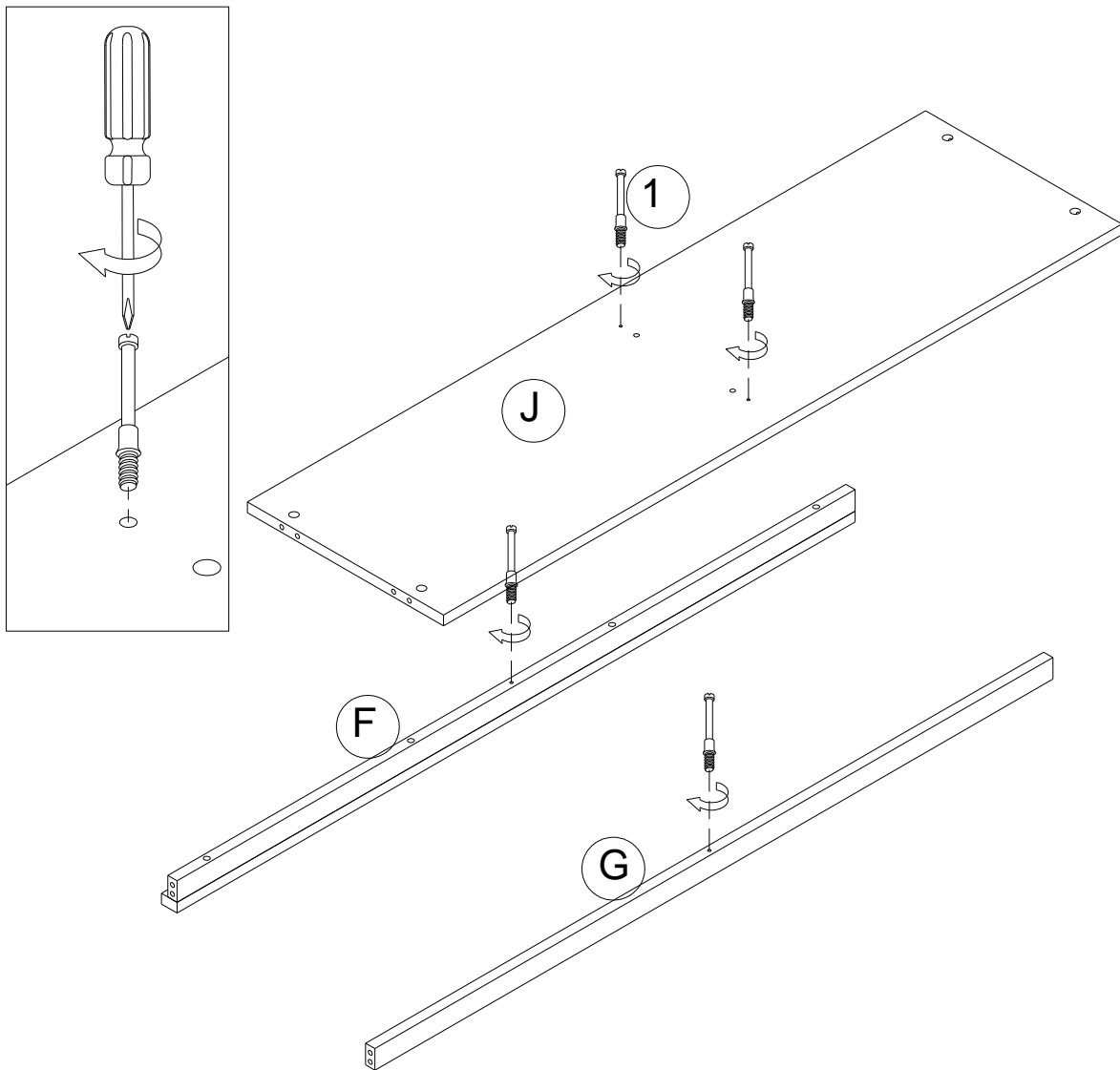

1		4 PCS
---	--	-------

COMMODE

DL8417-1

ÉTAPE 3

Insérez des goujons de bois (3) et des verrouillages à came (2) dans le panneau central (D) tel qu'illustré.

Fixez le panneau central (D) au panneau inférieur arrière (J) en tournant les verrouillages à came 1/2 tour dans le sens horaire à l'aide d'un tournevis cruciforme (non compris)

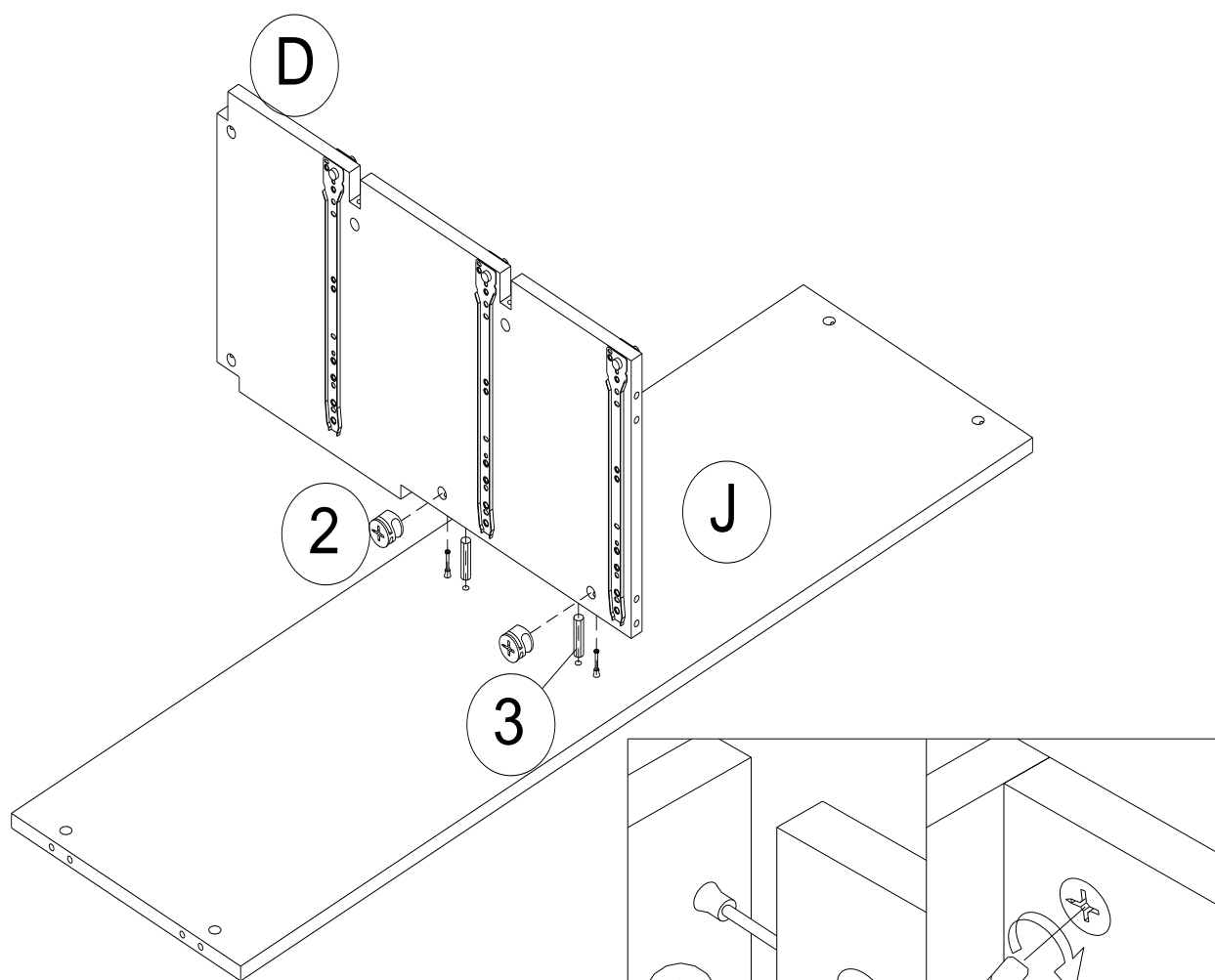

2		2 PCS
3		2 PCS

COMMODE

DL8417-1

ÉTAPE 4

Insérez des verrouillages à came (2) et des goujons de bois (3) dans les barres (E, F, G et H), dans le panneau inférieur arrière (J) et dans les panneaux latéraux (B et C) tel qu'illustré. Raccordez les barres (E, F, G et H) avec le panneau central (D) tel qu'illustré.

Fixez les barres (E, F, G et H) avec le panneau central (D) en tournant les verrouillages à came (2) 1/2 tour dans le sens horaire à l'aide d'un tournevis cruciforme (non compris).

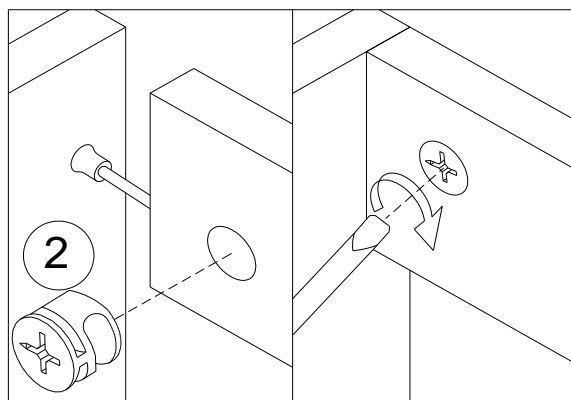
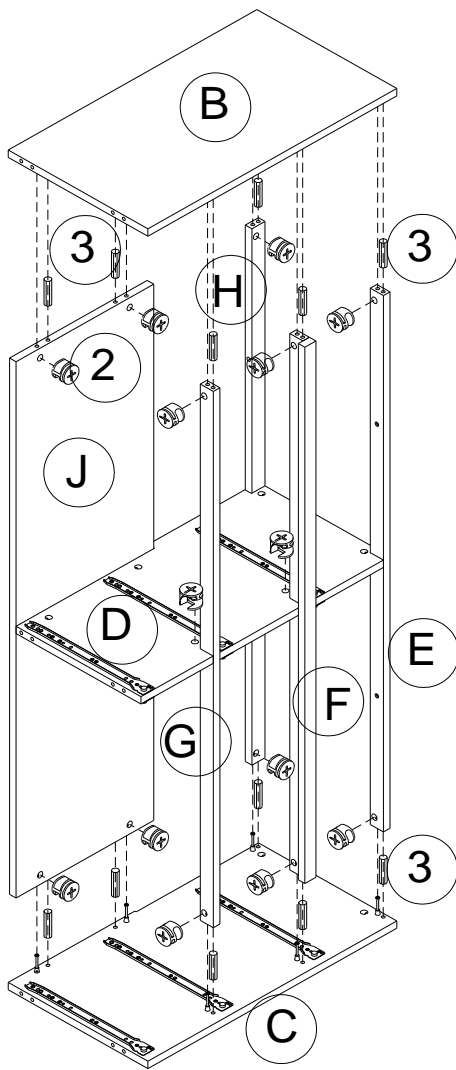

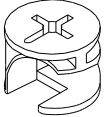
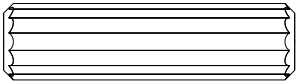
2		14 PCS
3		12 PCS

COMMODE

DL8417-1

ÉTAPE 5

Insérez des goujons de bois (3) dans le panneau inférieur (T).

Attachez les barres transversales (W), la barre inférieure de base (U), la barre supérieure de base (V) et le pied de support (Y) avec le panneau inférieur (T) avec des boulons (8). Servez-vous de la clé Allen (7) pour serrer les boulons.

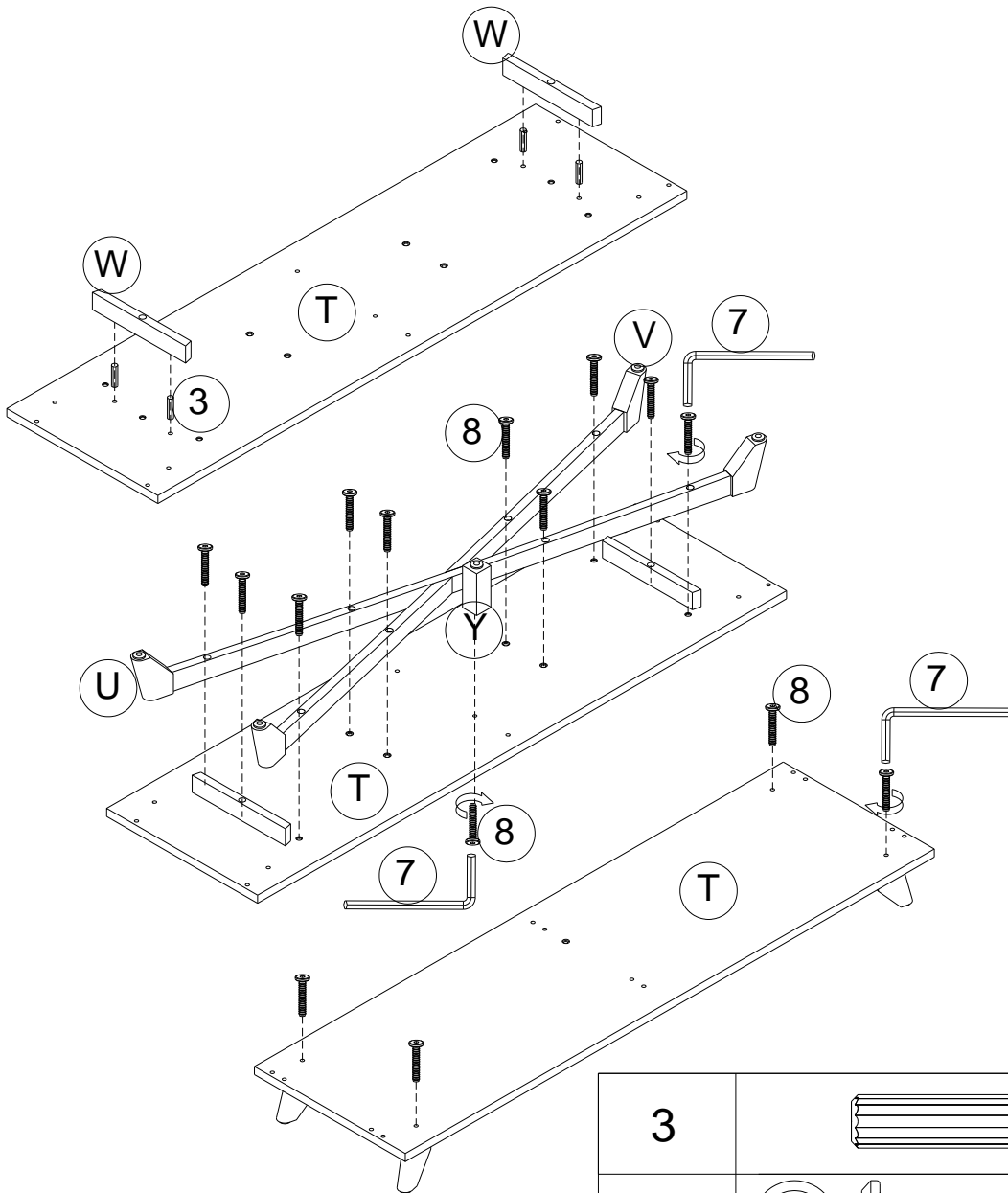

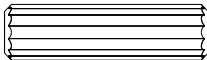
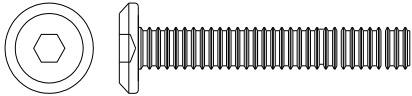
3		4 PCS
8		15 PCS

COMMODE

DL8417-1

ÉTAPE 6

Insérez des goujons de bois (3) dans le panneau inférieur (T). Attachez le panneau inférieur (T) avec les panneaux latéraux (B et C) et le panneau central (D) avec des boulons (8). Servez-vous de la clé Allen (7) pour serrer les boulons.

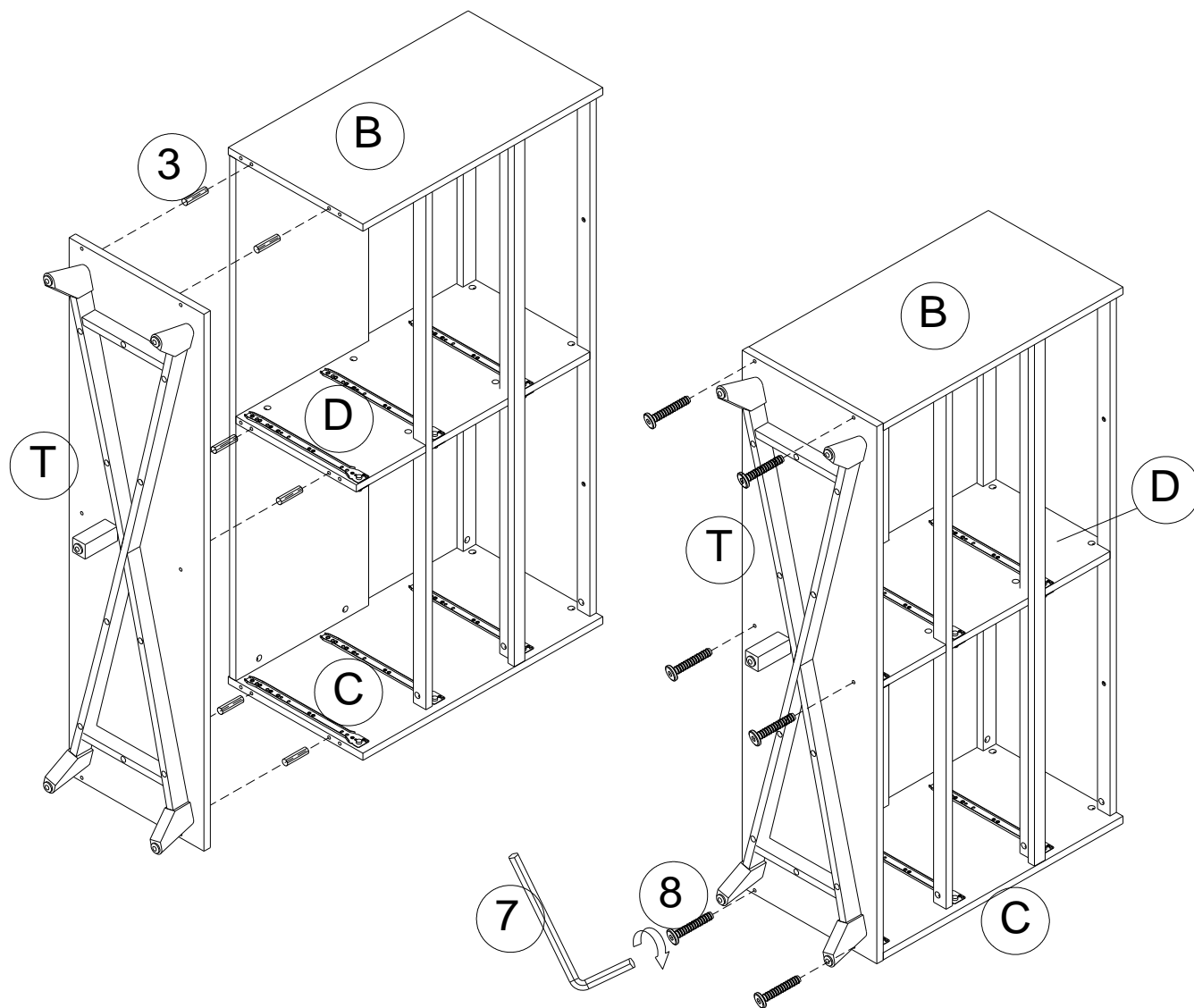

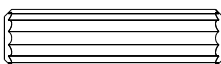
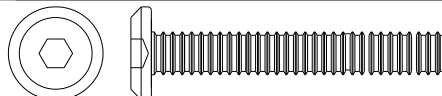
3		6 PCS
8		6 PCS

COMMODE

DL8417-1

ÉTAPE 7

Insérez des verrouillages à came (1) dans le dessus de la commode (A) tel qu'illustré.

Insérez des verrouillages à came (2) et des goujons de bois (3) dans les panneaux latéraux (B et C) et dans le panneau central (D) tel qu'illustré.

Attachez le dessus de commode (A) avec l'unité et fixez-le en tournant les verrouillages à came (2) 1/2 tour dans le sens horaire à l'aide d'un tournevis cruciforme (non compris).

Fixez complètement le dessus de la commode (A) avec l'unité déjà assemblée avec des vis (12) à l'aide d'un tournevis cruciforme (non compris).

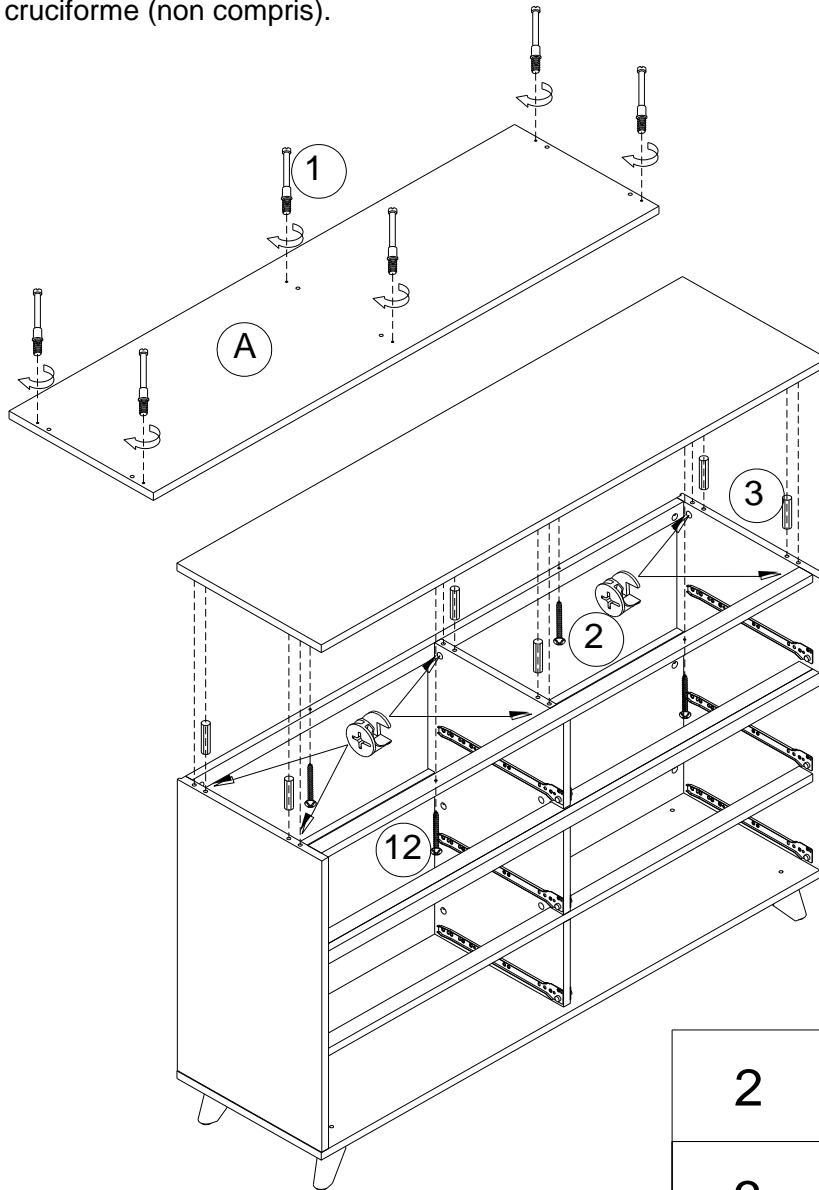

			2		6 PCS
			3		6 PCS
1		6 PCS	12		4 PCS

COMMODE DL8417-1

ÉTAPE 8

Attachez le panneau supérieur arrière (I) avec l'unité déjà assemblée avec des vis (15) à l'aide d'un tournevis cruciforme (non compris).

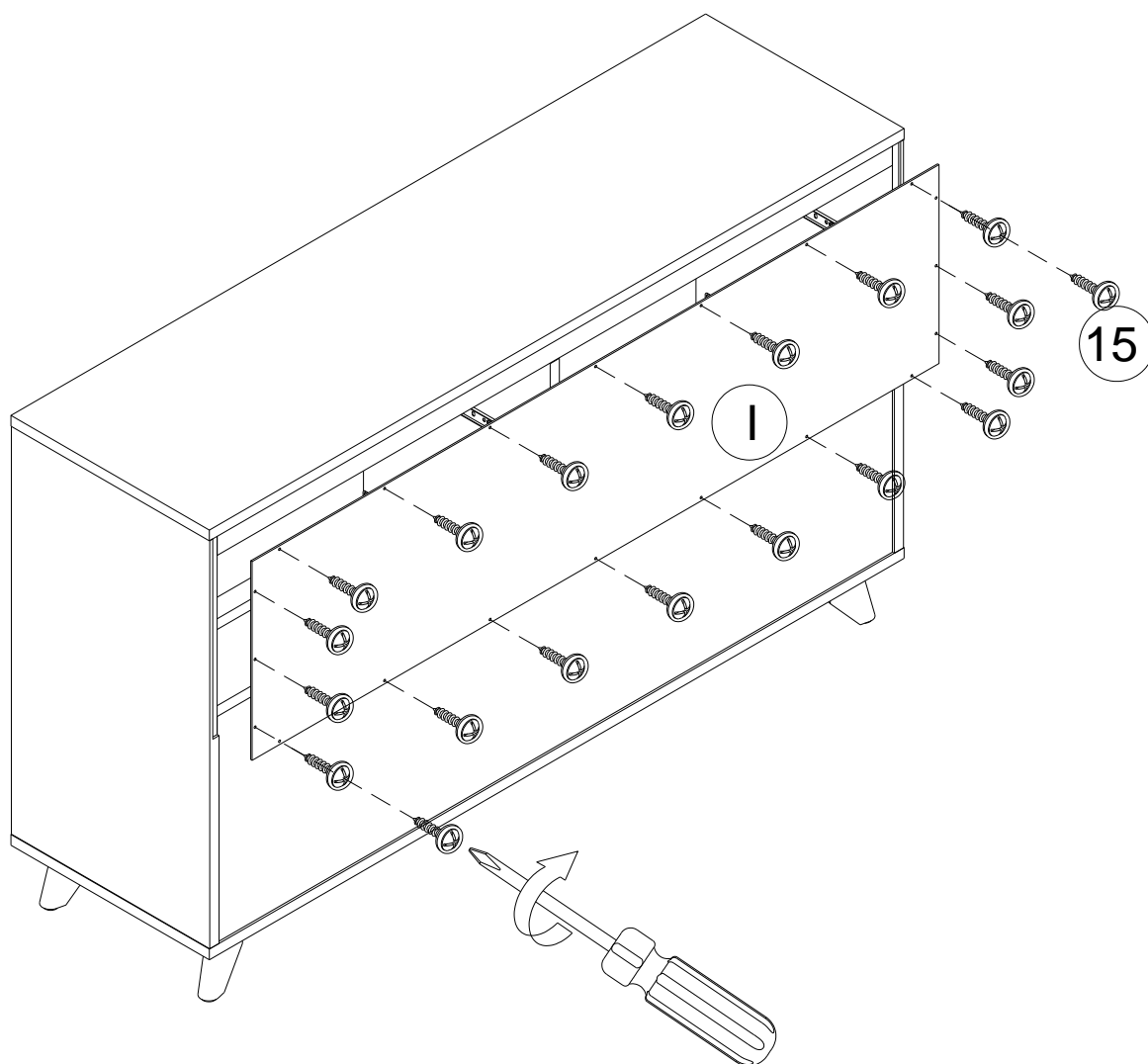

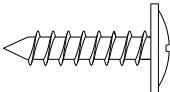
15		20 PCS
----	--	--------

COMMODE

DL8417-1

ÉTAPE 9

Insérez des boulons à came (4) dans les devants des tiroirs (K, L, M et N) tel qu'illustré.

Insérez des goujons de bois (6) et des verrouillages à came (5) dans les côtés gauche et droit (O et P) tel qu'illustré.

Fixez les côtés des tiroirs (O et P) avec les devants des tiroirs (K, L, M et N) en tournant les verrouillages à came (5) 1/2 tour dans le sens horaire à l'aide d'un tournevis cruciforme (non compris).

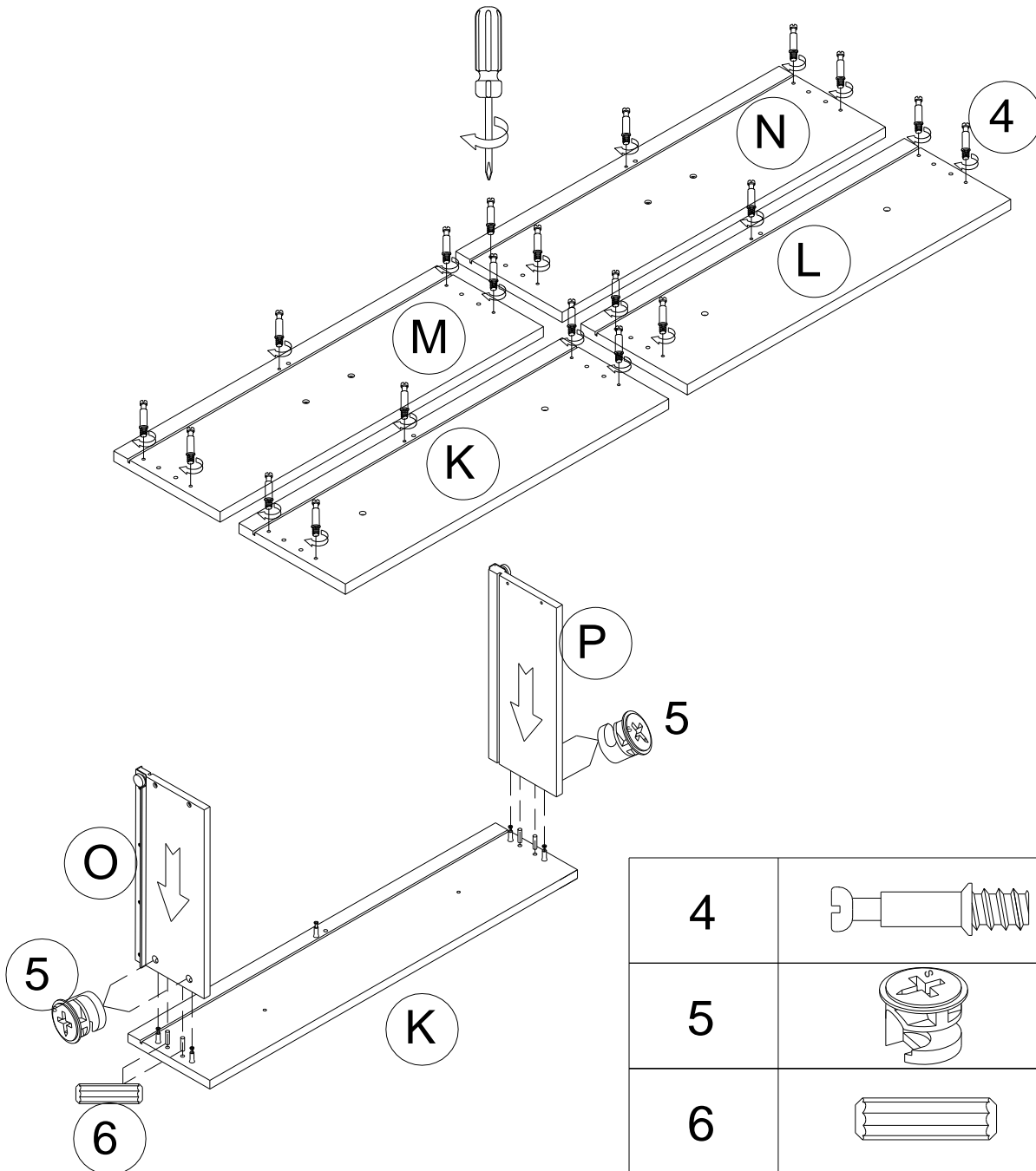

4		30 PCS
5		24 PCS
6		24 PCS

COMMODE DL8417-1

ÉTAPE 10

Glissez le fond du tiroir (R) dans les rainures des côtés gauche et droit et du devant du tiroir.

Insérez un goujon de bois (6) et un verrouillage à came (5) dans la barre inférieure du tiroir (S) tel qu'illustré.

Fixez la barre inférieure du tiroir (S) avec le devant du tiroir en tournant le verrouillage à came (5) 1/2 tour dans le sens horaire à l'aide d'un tournevis cruciforme (non compris).

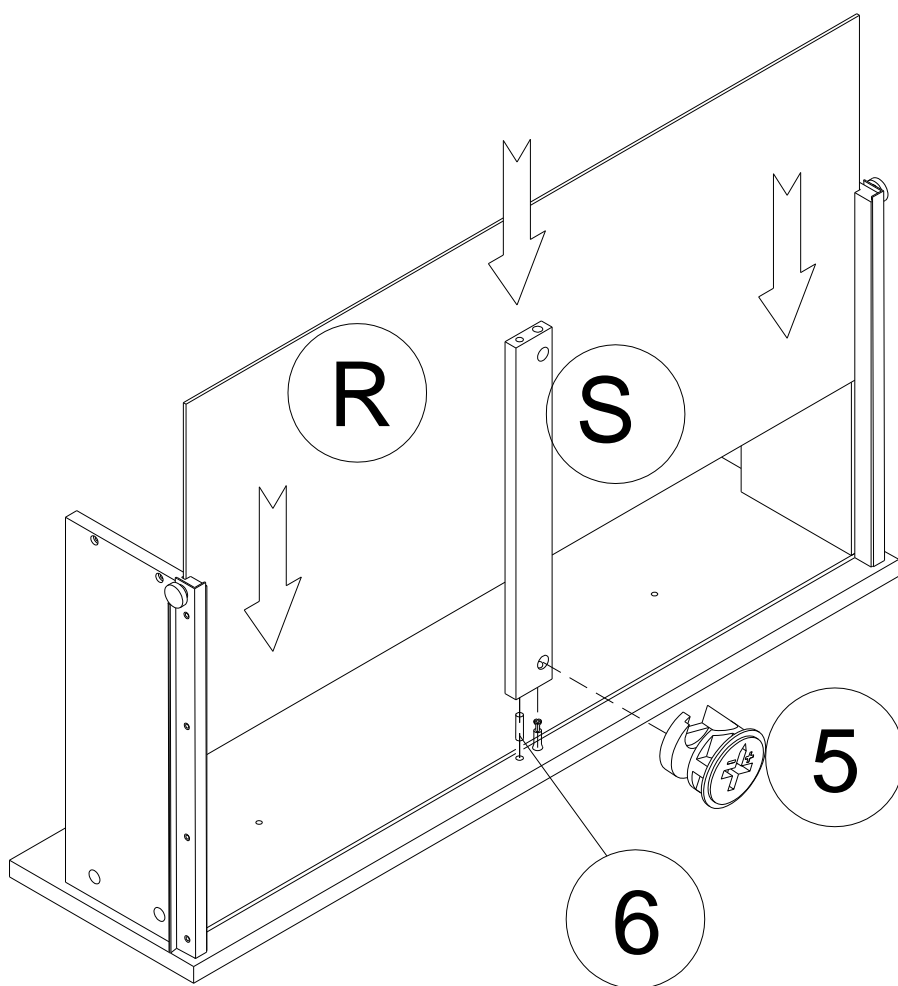

6		6 PCS
5		6 PCS

COMMODE DL8417-1



ÉTAPE 11

Insérez un goujon de bois (6) et un verrouillage à came (5) dans la barre inférieure du tiroir (S) tel qu'illustré.

Attachez le côté arrière du tiroir (Q) avec les côtés des tiroirs avec des vis (13) et des écrous transversaux de plastique (14). Fixez la barre inférieure du tiroir (S) avec le côté arrière du tiroir (Q) en tournant le verrouillage à came (5) 1/2 tour dans le sens horaire à l'aide d'un tournevis cruciforme (non compris).

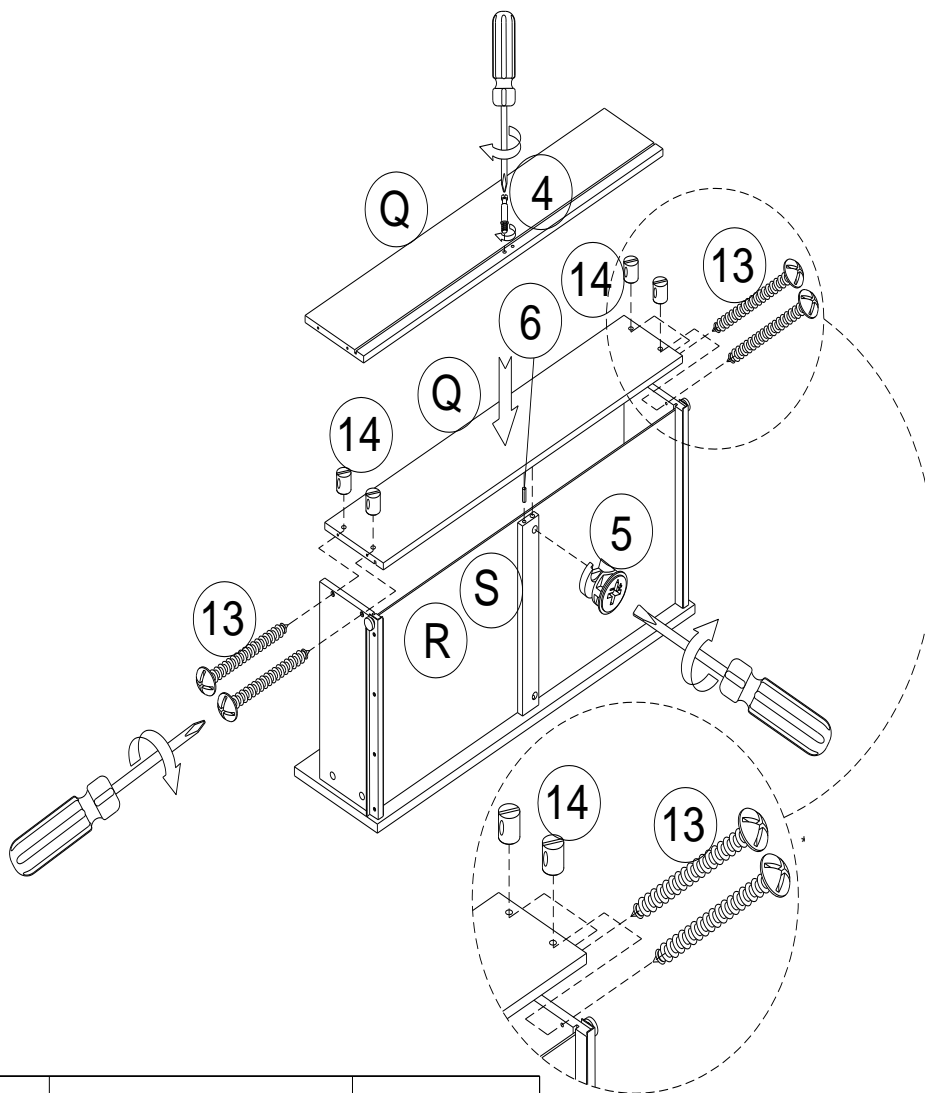
Répétez les étapes précédentes pour assembler les autres tiroirs.

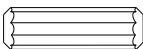

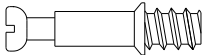
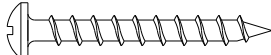
6		6 PCS			
5		6 PCS	14		24 PCS
4		6 PCS	13		24 PCS

COMMODE



DL8417-1

ÉTAPE 12

Fixez les boutons (10) et les poignées (11) avec des boulons (9) à l'aide d'un tournevis cruciforme (non compris).

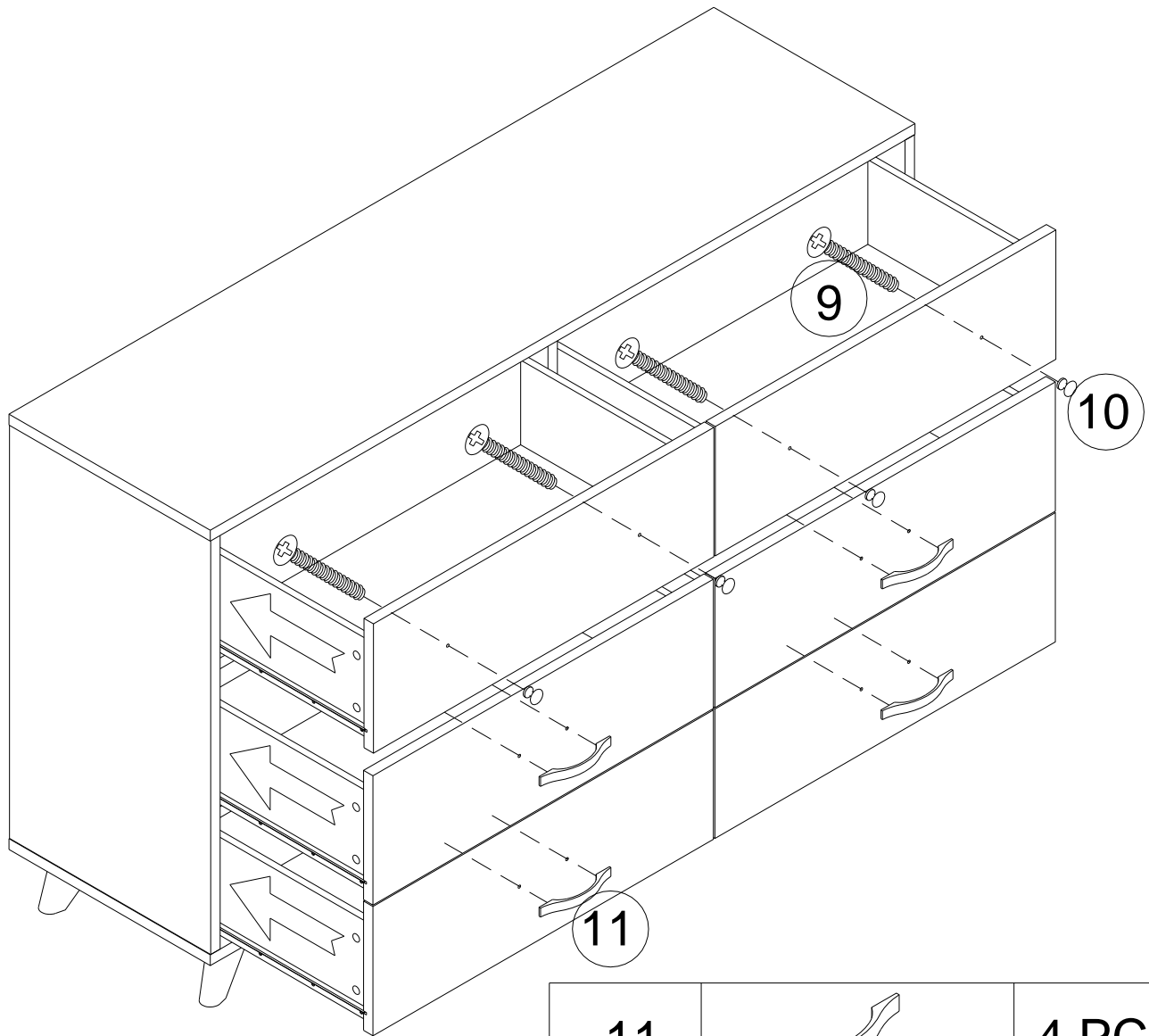
Insérez tous les tiroirs dans la commode assemblée.

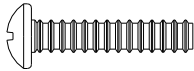

11		4 PCS
10		4 PCS
9		12 PCS

COMMODE DL8417-1

! **ATTENTION:** Cette unité est conçue pour être utilisée uniquement avec les produits et/ou les poids maximum indiqués. L'utilisation avec d'autres produits et/ou des produits plus lourds que les poids maximum indiqués peut causer de l'instabilité ou des blessures.

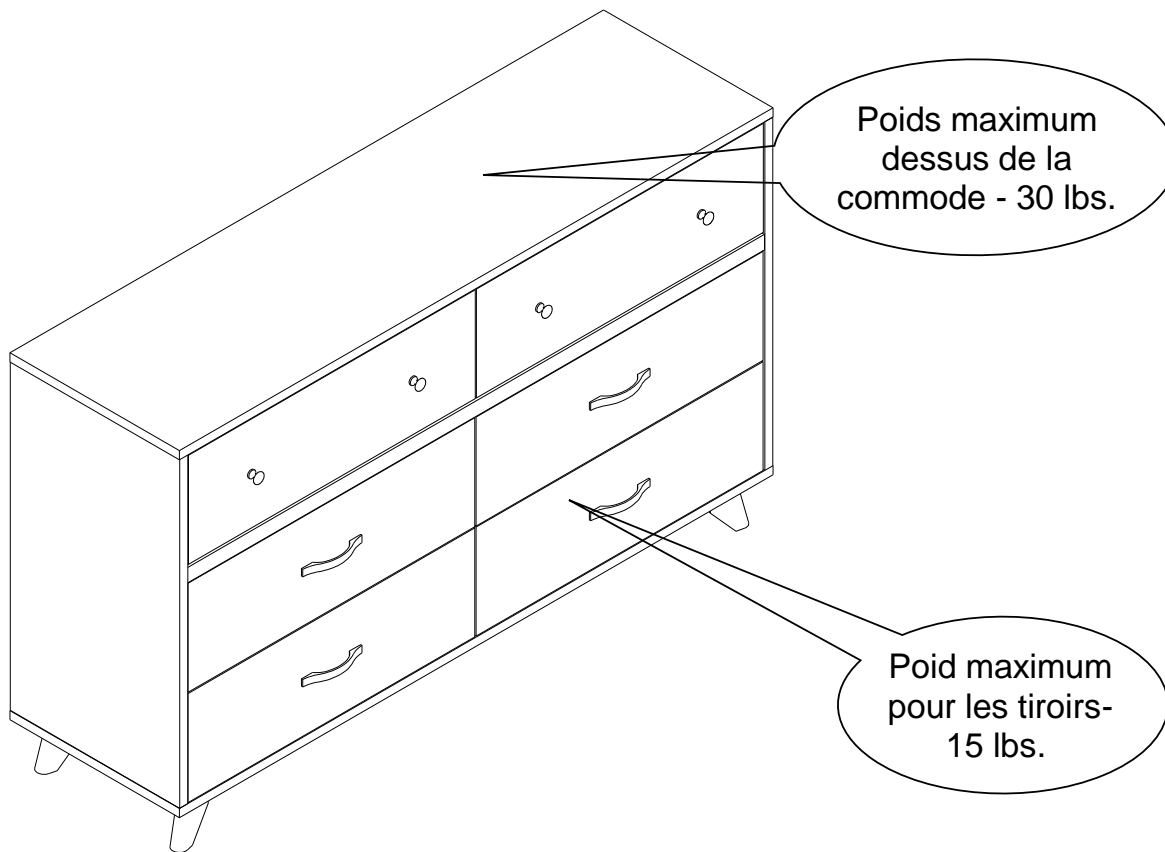

C'est tout! Vous avez fini de monter votre bureau.





NE PAS RETOURNER CE PRODUIT DÉTAILLAN

Si une pièce est manquante ou endommagée, contactez le représentant de notre Service à la clientèle. Nous remplacerons la pièce **GRATUITEMEN**

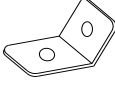

Tél #: 1-800-295-198
Courriel: das@dorel.co

Liste de quincaillerie

A	B	C	D
			
CROCHET DE MÉTAL 4 PCS	SANGLE DE SÉCURITÉ POUR LE MUR - 2 PCS	VIS LONGUE 2 PCS	VIS COURTE 2 PCS

OUTILS NÉCESSAIRES: LE MAILLET EN CAOUTCHOU ET LE TOURNEVIS PHILLIPS NE SONT PAS COMPRIS.

NOTE: LA MÈCHE DE 5/16" ET LA PERCEUSE ÉLECTRIQUE NE SONT PAS FOURNIES.

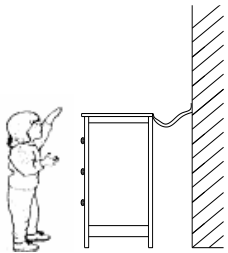

AVERTISSEMENT: LORSQUE DEBOUT, IL EST POSSIBLE QUE LE MEUBLE PUISSE BASCULER. VEUILLEZ INSTALLER LA SANGLE DE SÉCURITÉ POUR LE MUR DERRIÈRE LE MEUBLE POUR EN ASSURER DE LA SÉCURITÉ.

VEUILLEZ LIRE TOUTES LES INSTRUCTIONS AVEC ATTENTION AVANT D'UTILISER CE PRODUIT ET VEUILLEZ LES GARDER POUR RÉFÉRENCE FUTURE. SI VOUS AVEZ DES QUESTIONS, VEUILLEZ APPELER NOTRE NUMÉRO DE SERVICE AUX CLIENTS : 1-800-295-1980.

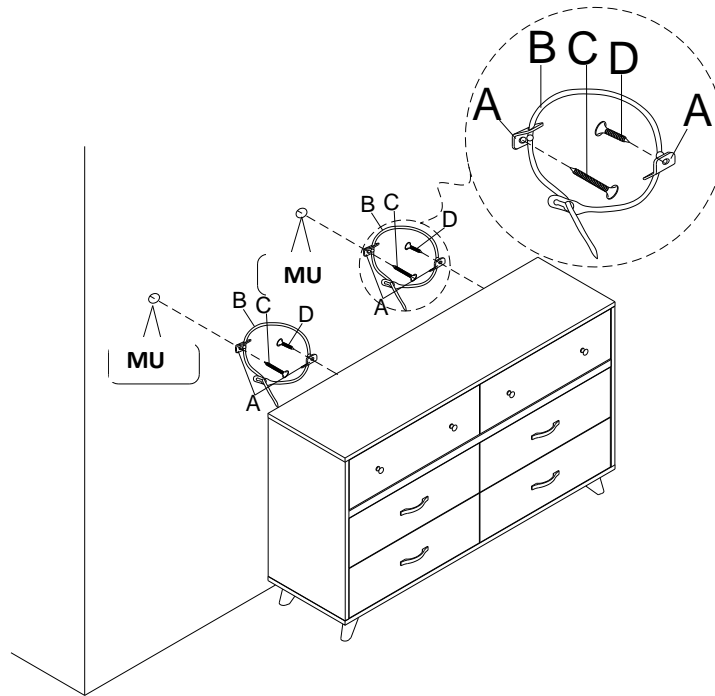

- ÉTAPE 1:** À L'AIDE DE LA VIS COURTE (D), FIXEZ FERMEMENT UN CROCHET DE MÉTAL (A) À LA BARRE TRANSVERSALE SUPÉRIEURE POSTÉRIEURE DU MEUBLE, À TRAVERS LE TROU LE PLUS PETIT
- ÉTAPE 2:** À L'AIDE D'UN ANCRAGE, PLACEZ L'AUTRE CROCHET DE MÉTAL (A) SUR LE MUR 2 POUCE EN-DESSOUS DU CROCHET DÉJÀ FIXÉ À LA PARTIE POSTÉRIEURE DU MEUBLE. FIXEZ À L'ENCRAGE DU MUR À L'AIDE DE LA VIS LONGUE (C), À TRAVERS LE TROU LE PLUS PETIT.
- ÉTAPE 3:** PLACEZ LE MEUBLE DANS SA POSITION DE FAÇON À VOUS ASSURER QUE LES DEUX CROCHETS SOIENT ALIGNÉS VERTICALEMENT. LACEZ LE BOUT DE LA SANGLE DE SÉCURITÉ (B) À TRAVERS DU TROU LE PLUS GRAND DE CHAQUE CROCHET (A). RAMENEZ LES DEUX BOUTS ENSEMBLE ET GLISSEZ LE BOUT PLAT À TRAVERS L'EXTRÉMITÉ DE FIXATION JUSQU'À CE QU'ELLE SOIT BIEN ^{SCÉDÉE} SERRÉE.
- ÉTAPE 4:** ASSUREZ-VOUS QUE LA SANGLE SOIT BIEN LACÉE ET SERRÉE.

POUR DÉPLACER LE MEUBLE APRÈS AVOIR INSTALLÉ LA SANGLE AU MUR, SIMPLEMENT RETIREZ LA VIS DU MUR POUR DESSERRER LE SANGLE DE SÛRETÉ.