

HAWK HART



LED WALLPACK
50W | 5003 LUMENS | REPLACES 150W

ORDER NUMBER: **L-HH50-4UD-P-Z**

KEY BENEFITS

The versatility combines a sleek, low-profile wall pack design and high-output LEDs to provide an energy efficient, low maintenance LED wall pack suitable for outdoor applications such as residential, light commercial, apartments, carports, driveways, parking lots, building perimeters, loading areas, driveways and sign and building flood lighting. With built Level, it easily mounts to recessed junction boxes or flush mounts. The fixture may be wall or ground mounted in downward or upward orientation. The integrated LEDs last for 50,000 hours, so you never have to buy a bulb for the light.

APPLICATIONS

Suitable for outdoor applications such as residential, light commercial, apartments, carports, driveways, parking lots, building perimeters, loading areas, driveways, sign and building flood lighting

CERTIFICATIONS

• DLC 4.1 Premium • cUL-us Listed • Lighting Facts •



* Please refer to the DLC QPL website for the latest and most complete information at www.designlights.org/QPL

PRODUCT PERFORMANCE

SYSTEM WATTAGE	LED WATTAGE	LUMENS	LP/W	CRI	REPLACES (MH)
50W	45W	5003 lm	100 lm/w	≥80	150W

PRODUCT SUMMARY

EFFICACY	100 lm/w
LED CHIP	2835 Mid-Power
CCT	4000K
DRIVER	Dimmable LED power supplies, Current can be adjusted the 120-277V Dimming type is continuous, The product can dim to 10%
DRIVER EFFICIENCY	>85%
INDIVIDUAL CARTON DIMENSIONS	10 x 7 x 5 in
INDIVIDUAL CARTON WEIGHT	5.25 lbs
STANDARD LIFETIME	Design minimum 50,000 + hours
STANDARD WARRANTY	5 Years
WATER PROOFING GRADE	IP65

PRODUCT WEIGHT: 5.25 lbs

PRODUCT DIMENSIONS

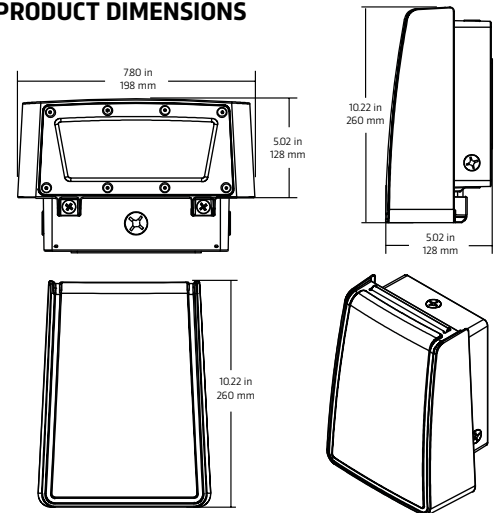

PRODUCT PHOTOMETRY

