

SG SERIES Retractable Awning

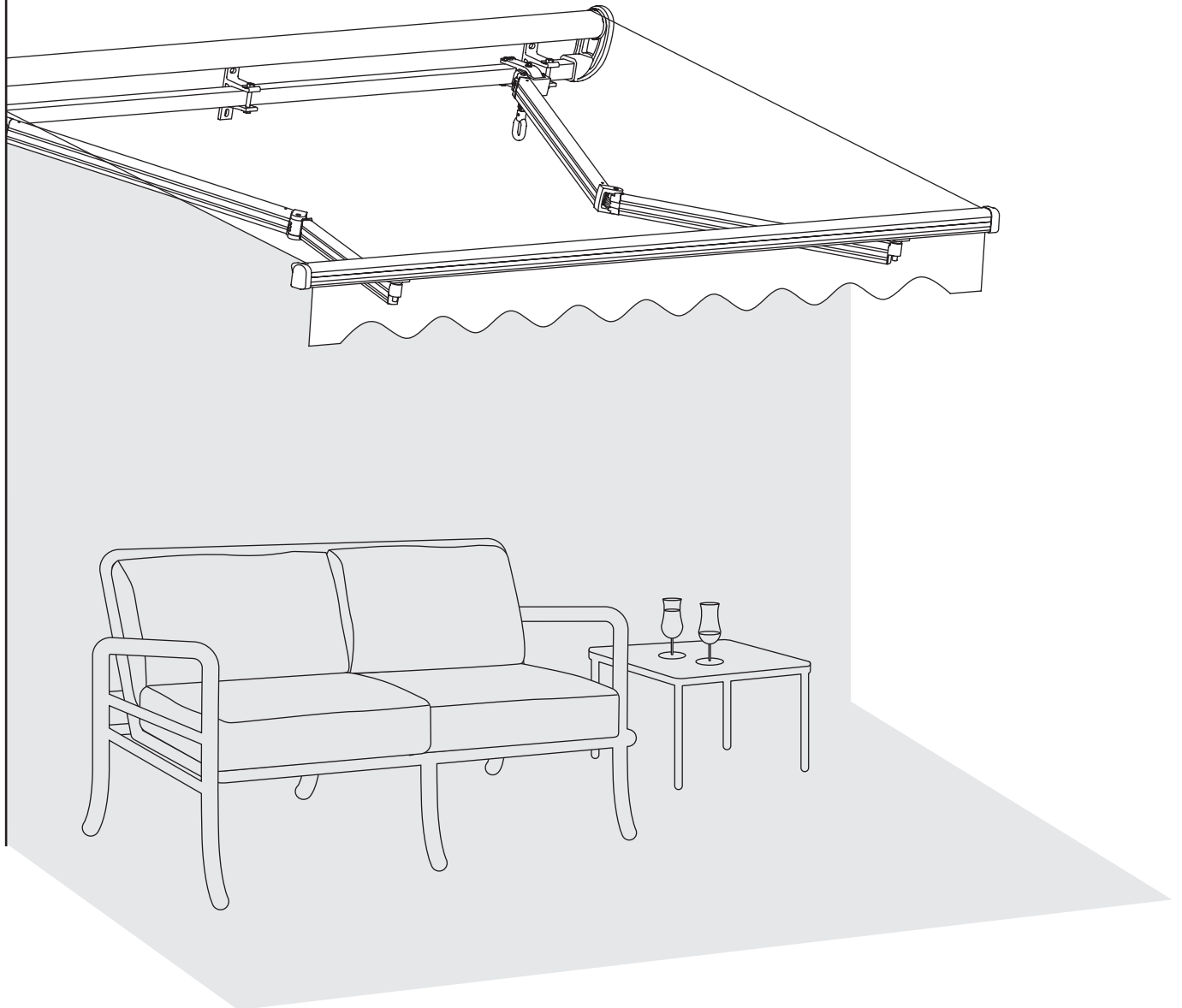

Owner's Manual

For safety reasons, please read the instructions and warnings in this manual carefully before installing the awning.

TABLE OF CONTENTS

Safety instructions and warnings.....	2
Package contents and parts	3
Tool requirements	4
Product features	4
Installation	
Bracket placement reference chart	5
Determine where to install your awning	6
Install wall brackets	
Standard stud installation	7
Masonry installation	8
Install ceiling brackets	11
Install awning onto brackets	12
Ready your awning	13
Operation	
Manual operation	13
Adjust awning pitch	14
Fabric rolling direction	14
Maintenance.....	15
Warranty.....	16

SAFETY INSTRUCTIONS



In order to avoid accidental injury or damage, **DO NOT** remove any awning arm safety restrains until instructed to do so.

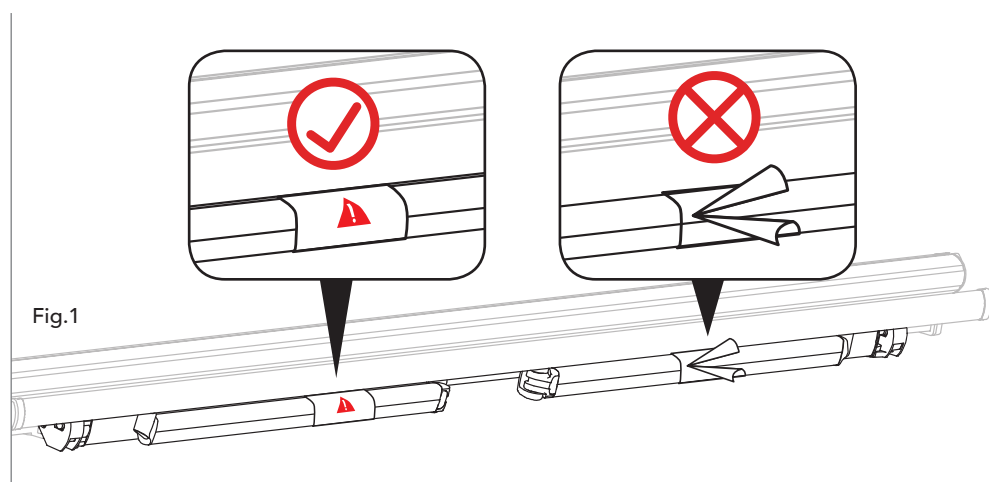

SAFETY INSTRUCTIONS AND WARNINGS

TO REDUCE THE RISK OF FIRE, ELECTRIC SHOCK, OR INJURY

- Pay close attention during installation to ensure that the Advaning awning is installed properly.
- Perform the installation in dry and optimal conditions. Always wear protective gear and gloves when handling sharp metal parts. If you do not feel that you can properly install the awning, please seek professional help.
- The Advaning awning should only be operated by an adult that understands all the functions and operations of the awning. Please keep unsupervised children away from playing with the awning or its parts.
- The product should be used only as described in this Advaning Owner's manual. Do not carry out any maintenance other than what is shown in this manual. For any issues that are not covered in this manual, please seek support from Advaning Customer Service.
- Only use Advaning recommended accessories and original replacement parts.
- Do not place, hang, or stand objects or persons on the awning itself, doing so can damage the awning or cause severe personal injury and in extreme cases death.

DO NOT keep the awning open during:
A: RAIN
B: SNOW
C: STRONG WIND
D: AWAY FROM HOUSE

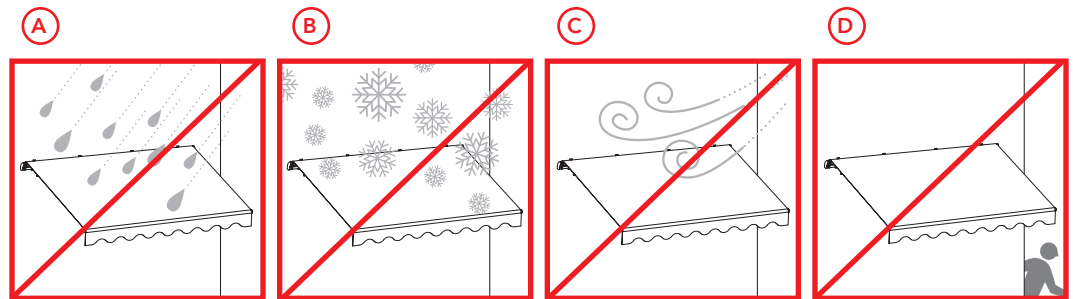
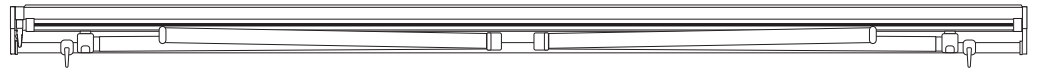

Fig.2

PACKAGE CONTENTS AND PARTS

Check to make sure the package contain all parts shown in the parts list before installation.



Awning unit Qty: 1



Hand crank Qty: 1 (63 Inches Length)

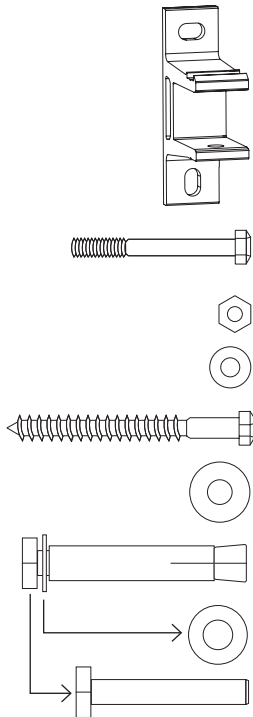

Model		8'~10'	12'~16'
Parts name		Quantity	
Wall bracket set	Wall bracket	2	3
	Retaining hex bolt	2	3
	Retaining nut	2	3
	5/16" washer	2	3
3/8"x4" Lag screw		4	6
3/8" Flat washer		4	6
Expansion bolt set	Expansion bolt	4	6
	Washer	4	6
	Hex bolt	4	6

OPTIONAL CEILING MOUNT PARTS

(Additional parts purchase needed.)

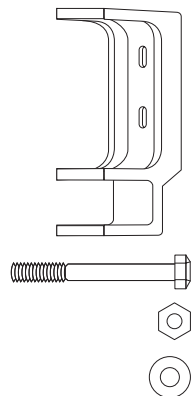

Fig.3

Awning Size (Width)		8'~10'	12'~16'
Parts name		Quantity	
Wall/ceiling dual bracket set	Wall/ceiling bracket	2	3
	Retaining hex bolt	2	3
	Retaining nut	2	3
	3/8" washer	2	3

TOOL REQUIREMENTS



Minimum 2 people to install

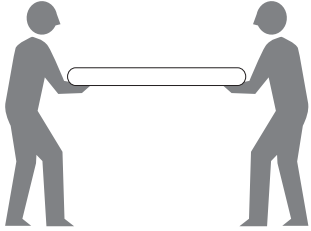

SUGGESTED TOOLS

- ① Marker / pencil
- ② Measuring tape
- ③ Electronic Stud finder
- ④ Chalk line / laser level
- ⑤ Level
- ⑥ 3/8" socket wrench
- ⑦ Drill bit
- ⑧ Masonry drill bit
- ⑨ Drill with bits
- ⑩ Ladders (2)

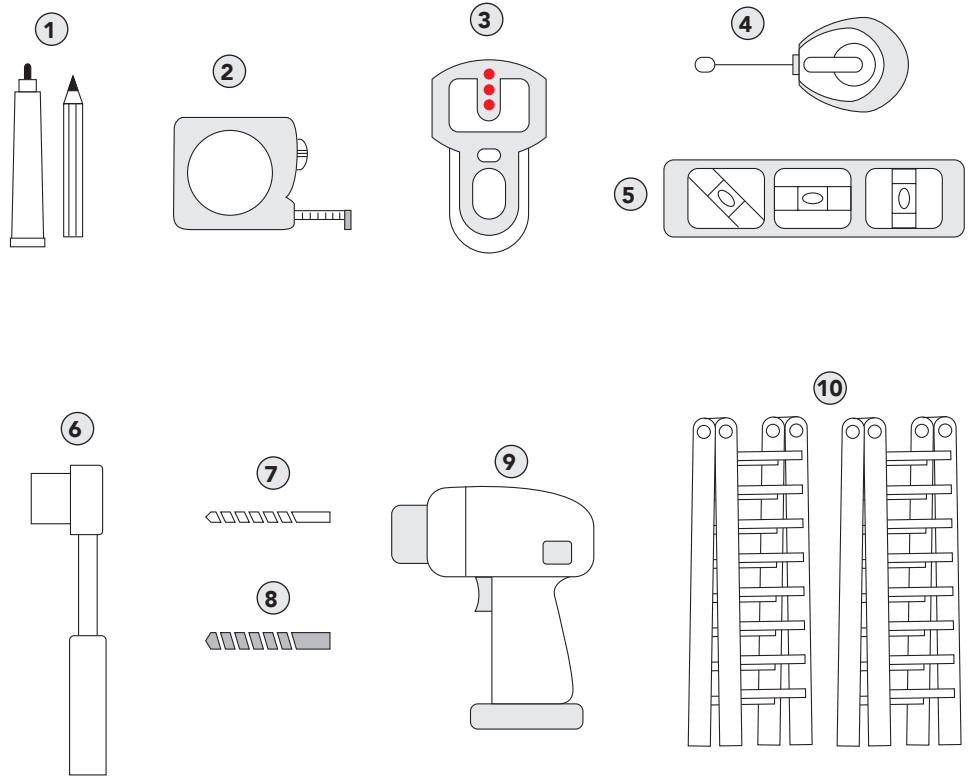

Fig.4

PRODUCT FEATURES

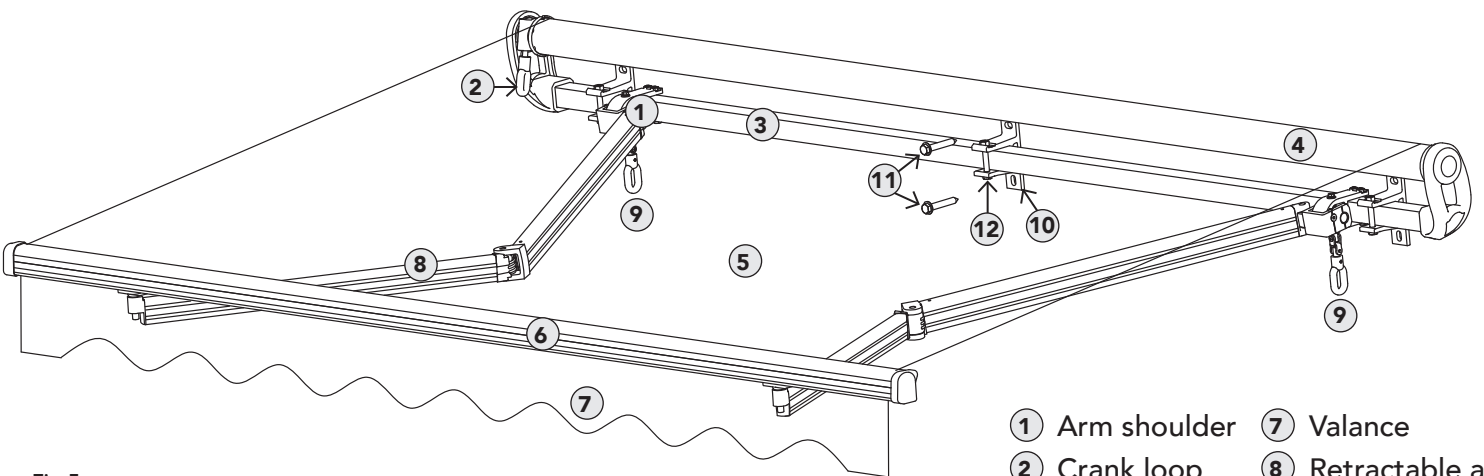

Fig.5

- | | |
|-----------------|--------------------|
| ① Arm shoulder | ⑦ Valance |
| ② Crank loop | ⑧ Retractable arms |
| ③ Torsion bar | ⑨ Easy Pitch™ loop |
| ④ Roller tube | ⑩ Wall bracket |
| ⑤ Awning fabric | ⑪ Lag screw |
| ⑥ Front bar | ⑫ Retaining bolt |

INSTALLATION

BRACKET PLACEMENT REFERENCE CHART

Please use the charts for bracket location reference.

- Ⓐ Left awning shoulder
- Ⓑ Right awning shoulder

NOTE: The left most bracket must be placed on the left side/outside of the left awning shoulder. The right most bracket must be placed on the right side / outside of the right awning shoulder.



ALL brackets must be placed and mounted onto wall studs or other major support structure.

8 ~ 10 feet awning

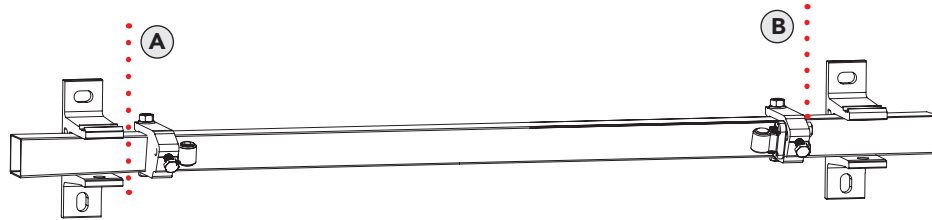

12 ~ 16 feet awning

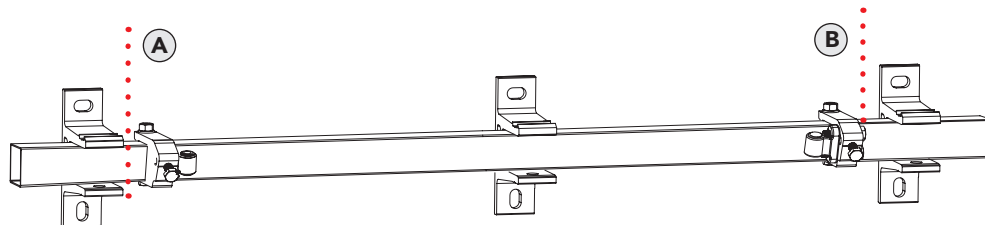

Fig.6

INSTALLATION

DETERMINE WHERE TO INSTALL YOUR AWNING

Locate a position that is

- Ⓐ Recommended 8~10 feet above the ground/floor/deck.
- Ⓑ Minimum 1 inch clearance below the roof/eave/overhang.
- Ⓒ With at least 12 vertical inch of clear space.



The surface should be free and clear of any obstructions along the entirety of the awning.

- Ⓓ Minimum 8 feet width.

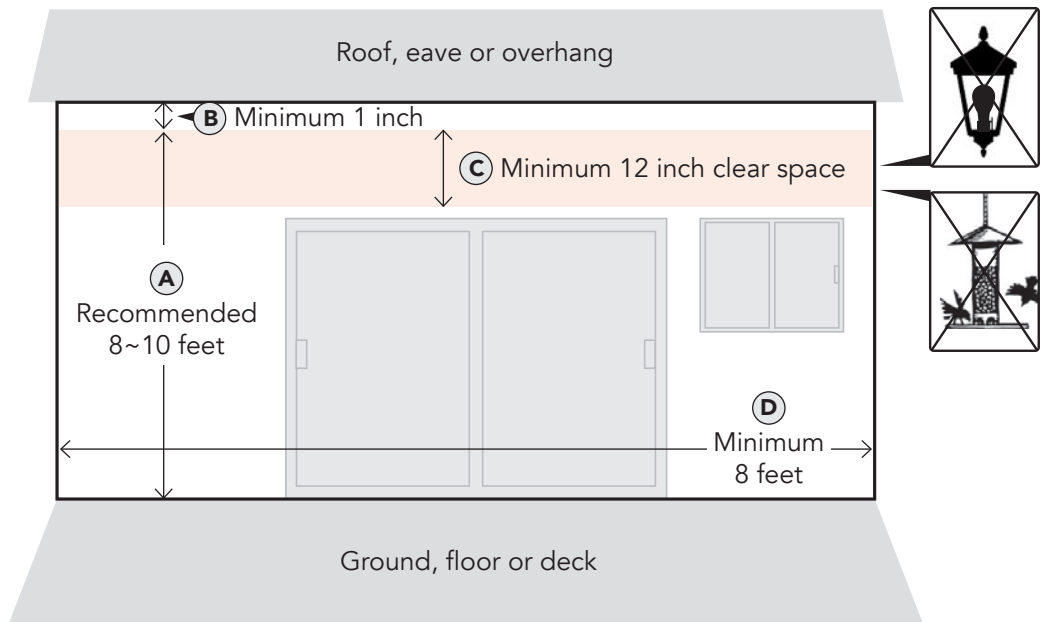

Fig 7

Side view

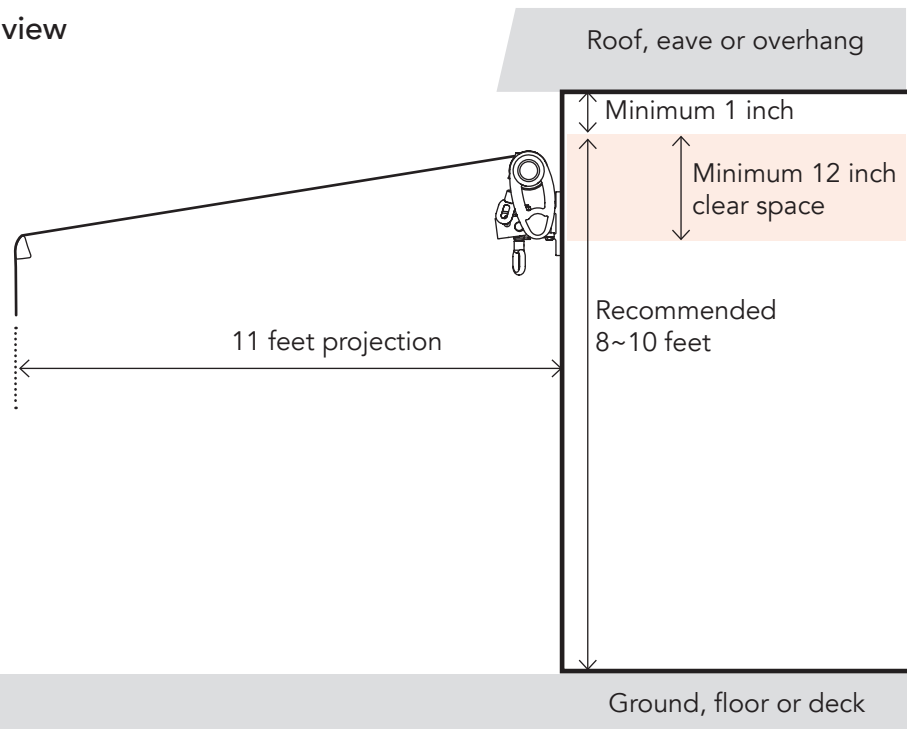

Fig 8

INSTALLATION

INSTALLING WALL BRACKETS

Standard stud installation

- ① Measure and mark where the top of your awning bracket will be placed.
- ② Use a regular level and chalk line or a laser level, mark a straight level line.
- ③ Locate and mark the center of the wall studs along this line using a stud finder. *Please follow the directions of your stud finder as instructed by the manufacturer.

CAUTION: Install the bracket onto wall studs based on the recommended bracket location (see page 5).

- ④ Align the top of the bracket to the chalk line.
- ⑤ Align the center of the bracket mounting holes with the center of the stud.
- ⑥ Use a level to make sure the bracket is straight and mark the center of the mounting holes.
- ⑦ Drill mounting holes using a drill bit.

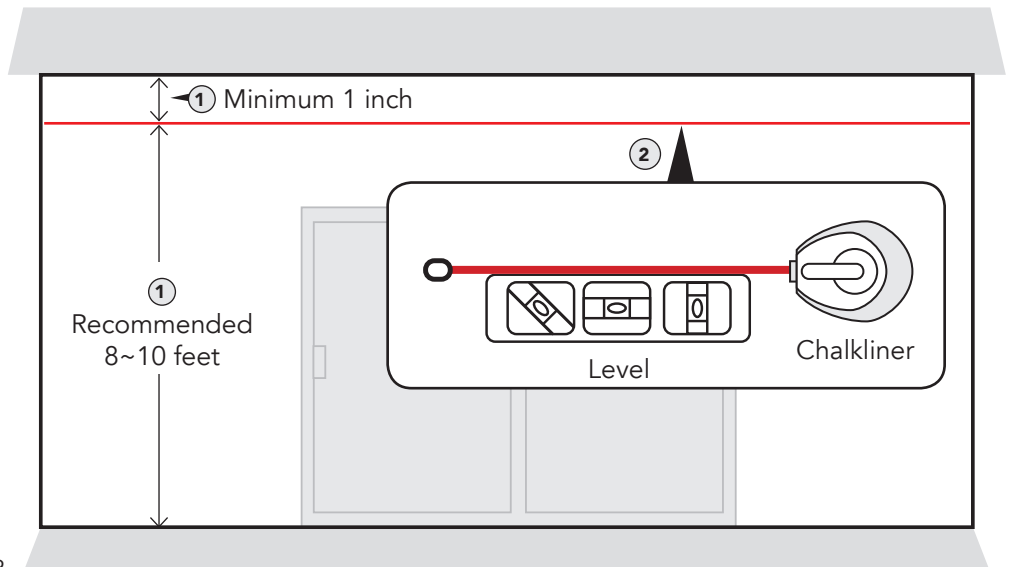

Fig 9

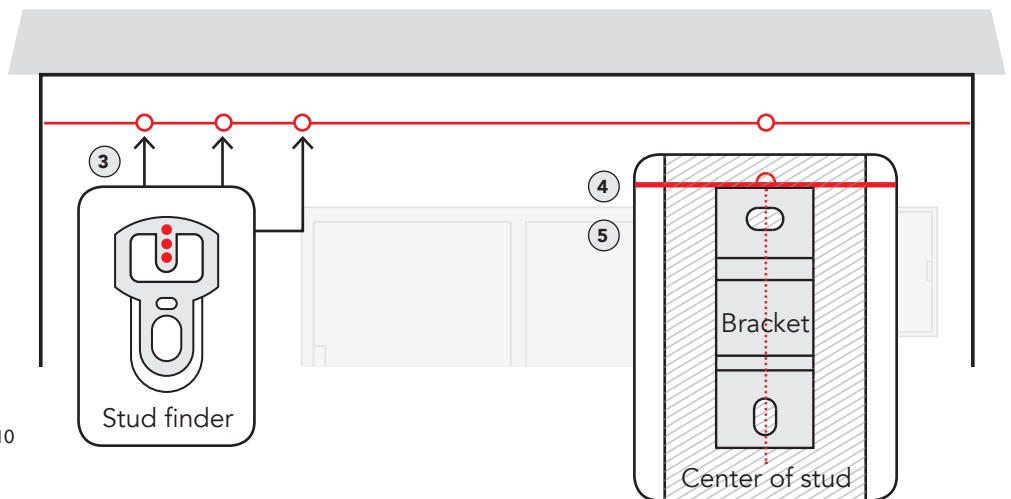

Fig 10

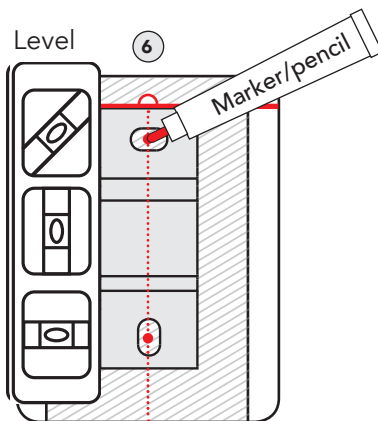

Fig 11

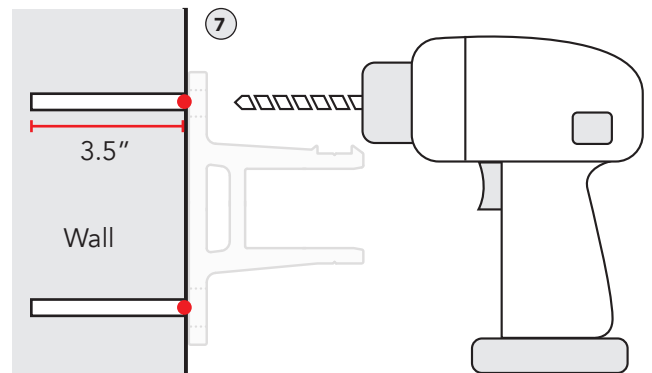

Fig 12

INSTALLATION

⑧ Place brackets over the appropriate holes and use a level to make sure the bracket is leveled and square to the line.

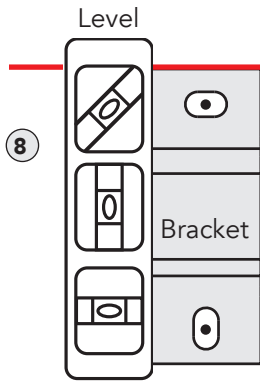

Fig 13

⑨ Use a washer and lag screw to secure all the brackets until snugged against the surface.

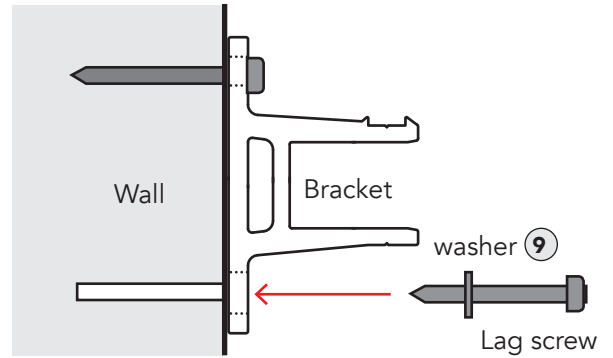

Fig 14

NOTE: For proper installation of brackets on uneven surfaces or siding, use shims or spacers to level the bracket.

Shims and spacers can also be used for vinyl or aluminum siding to provide a more solid surface for mounting.

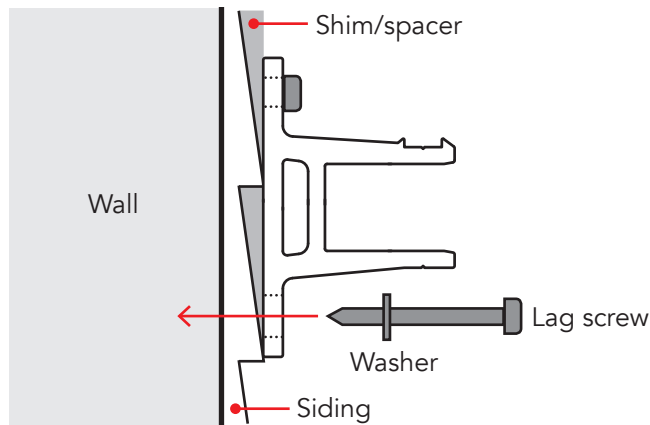

Fig 15

Masonry installation

For installing Advaning awning onto brick or solid concrete wall/surface.

CAUTION: Always install brackets securely to the brick or concrete and not in the grout to avoid collapse and personal injury.

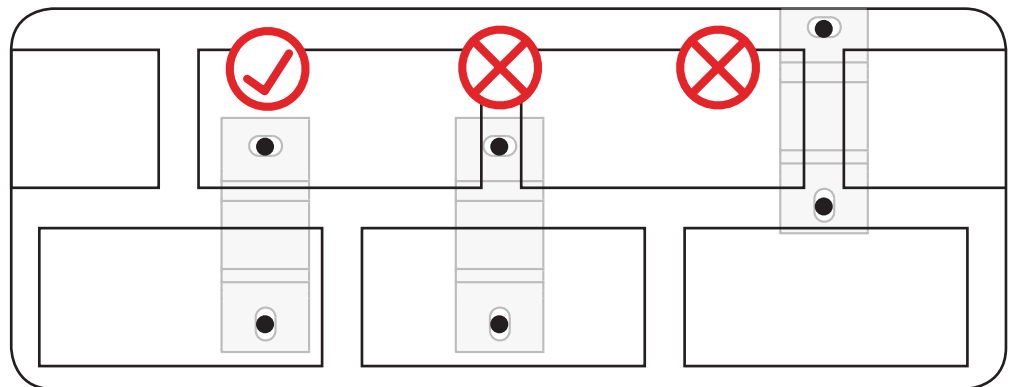

Fig 16

INSTALLATION

- 1 Follow instructions for standard installation step 1 and 2 (page 7).
- 2 Use recommended bracket location chart (page 5) to find bracket location for your awning model along the line.
- 3 Align the top of the bracket to the chalk line and use a level to make sure the bracket is straight.
- 4 Mark the center of the bracket mounting holes.
- 5 Drill mounting holes using a masonry drill bit.

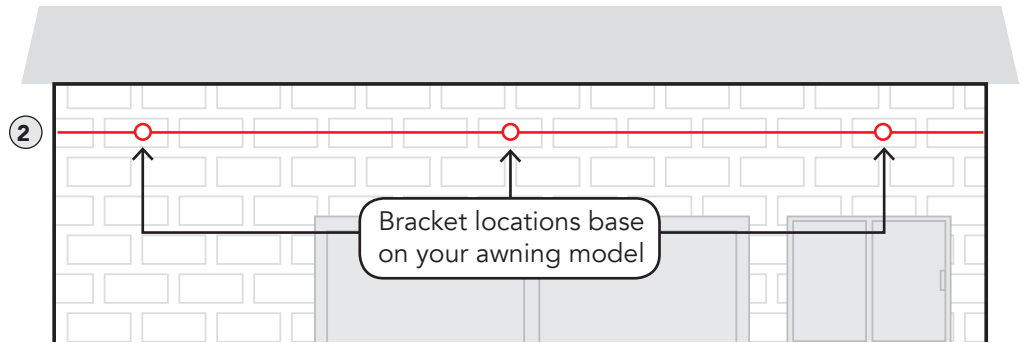

Fig 17

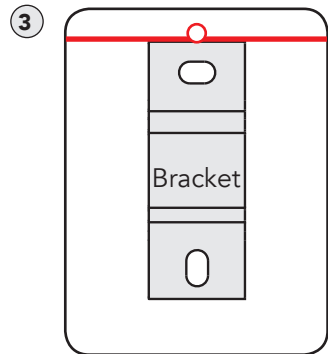

Fig 18

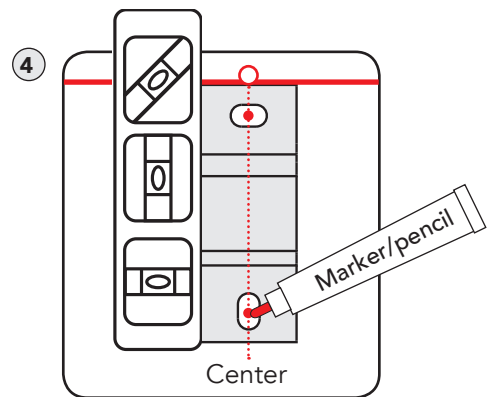

Fig 19

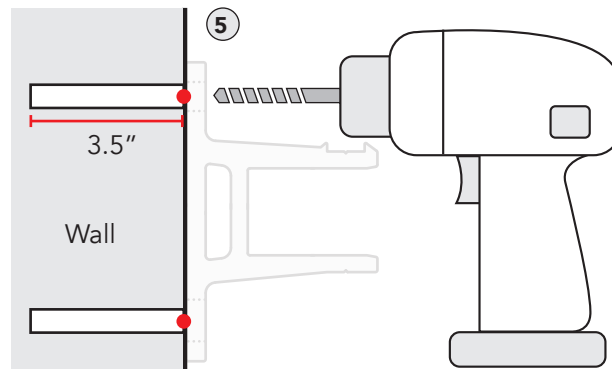

Fig 20

INSTALLATION

- ⑥ Insert an expansion bolt set into each of the drilled bracket holes.
- ⑦ Leave the hex bolt head outside of the hole.
- ⑧ Tighten the hex bolt head.

CAUTION: Do not over tighten.

- ⑨ Unscrew and remove only the hex bolt. Leave the expansion sleeve inside the hole.
- ⑩ Place the wall bracket over the holes and use a level to make sure the bracket is straight.
- ⑪ Re-insert the hex bolts into the holes through the wall bracket.
- ⑫ Tighten the hex bolts to secure wall bracket to surface.

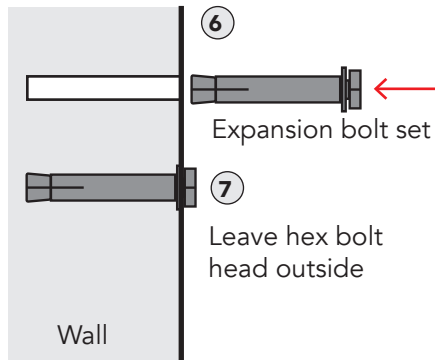

Fig 21

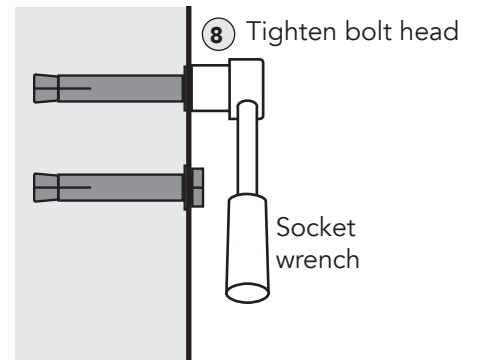

Fig 22

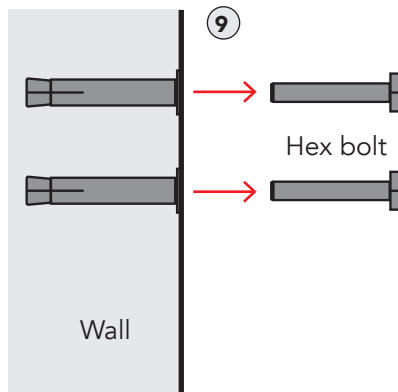

Fig 23

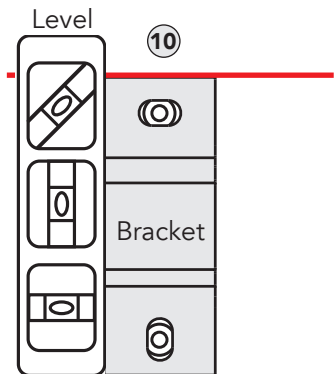

Fig 24

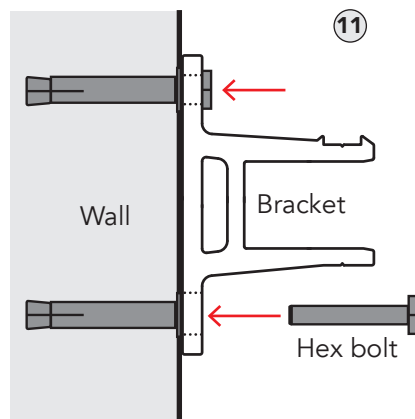

Fig 25

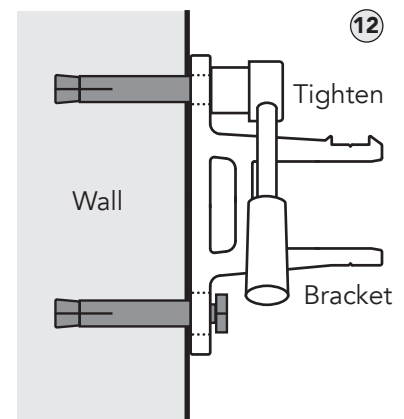

Fig 26

INSTALLATION

INSTALLING BRACKETS

NOTE: Parts not included. Additional purchase needed.

① Locate a straight, flat and leveled edge of your roof, eave or overhang that is clear and free of obstructions.

② Using a chalk line or laser level, mark a line that runs the entire length of your awning.

NOTE: The awning will stand 10" off of this line.

③ Use recommended bracket location chart (page 5) to determine bracket locations for your awning model along the line.

④ Place the brackets in the appropriate locations. Use a level to make sure the bracket is straight and mark the center of the mounting holes.

⑤ Drill mounting holes using a drill bit.

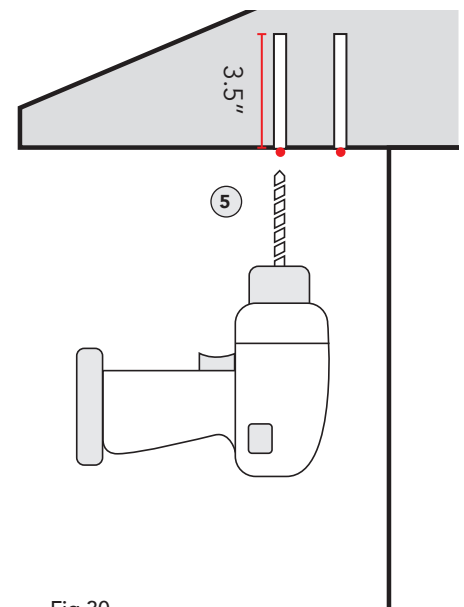
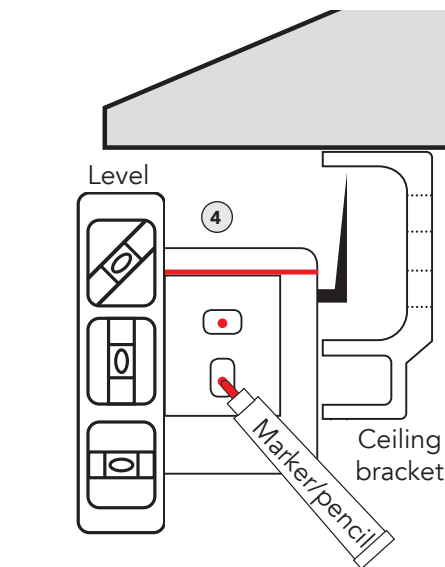
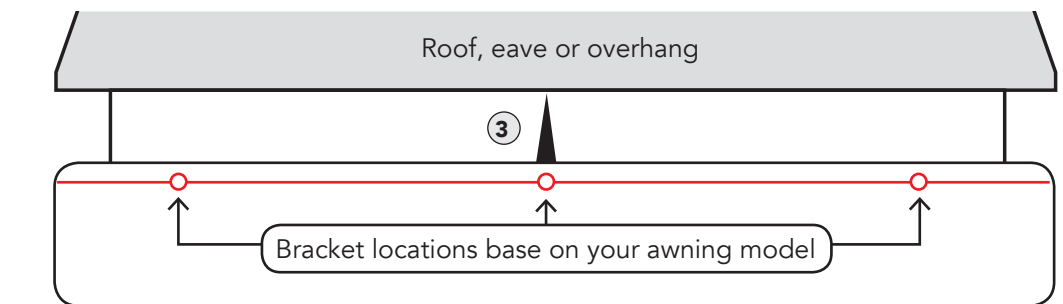
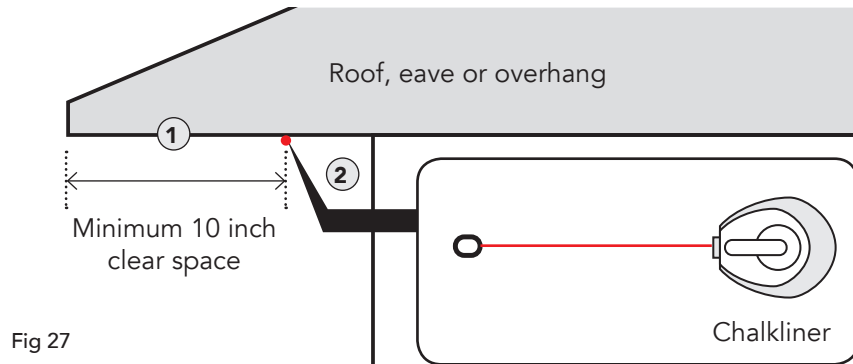

INSTALLATION

- ⑥ Place brackets over the appropriate holes.
- ⑦ Using a washer and a lag screw, secure the brackets to the surface until snug.
- ⑧ Attach wall bracket to the ceiling bracket using the provided bolts, washers and nuts.

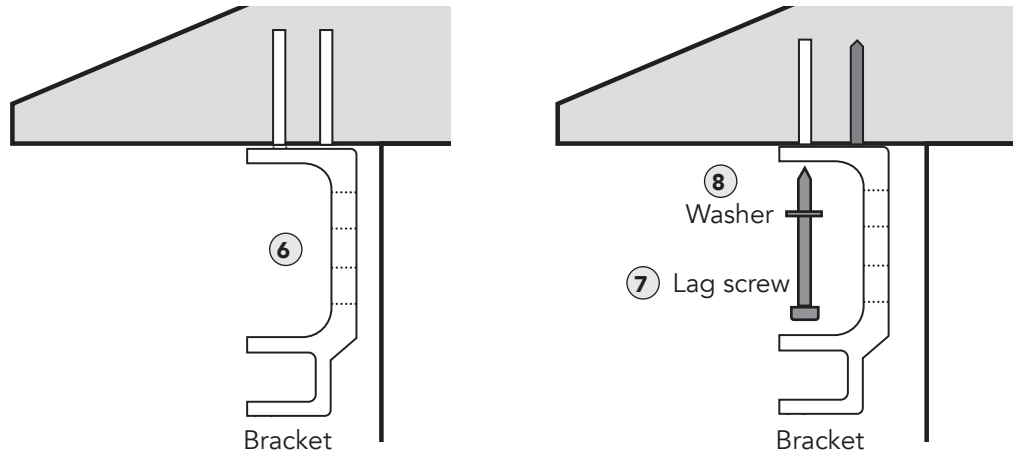

Fig 31

INSTALLING AWNING ONTO BRACKETS

- ① Remove the bolts on the front of the wall brackets.
- ② Slide the torsion bar into the square section of the bracket.
- ③ Place the retaining bolt into the bracket and use the nut and washer to secure the bolt into place.
- ④ Tighten the bolt with a socket wrench.

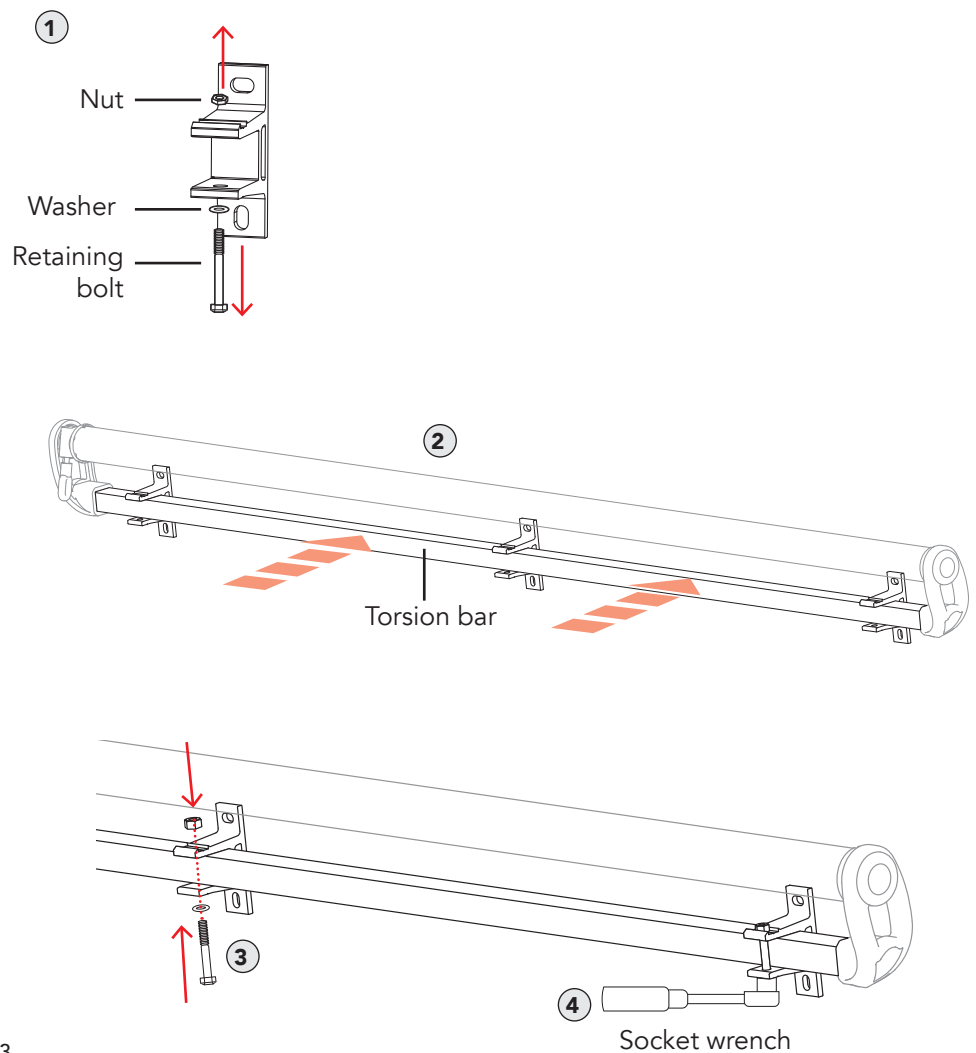

Fig 33

INSTALLATION

READY YOUR AWNING

NOTE: Before removing the safety restrains, make sure no persons or objects are in front of the awning. Failure to do so could result in personal injury.

- ① Position yourself under the awning.
- ② Remove the safety restrains from the arms one at a time. Do not use a knife or blade to cut the restrains.

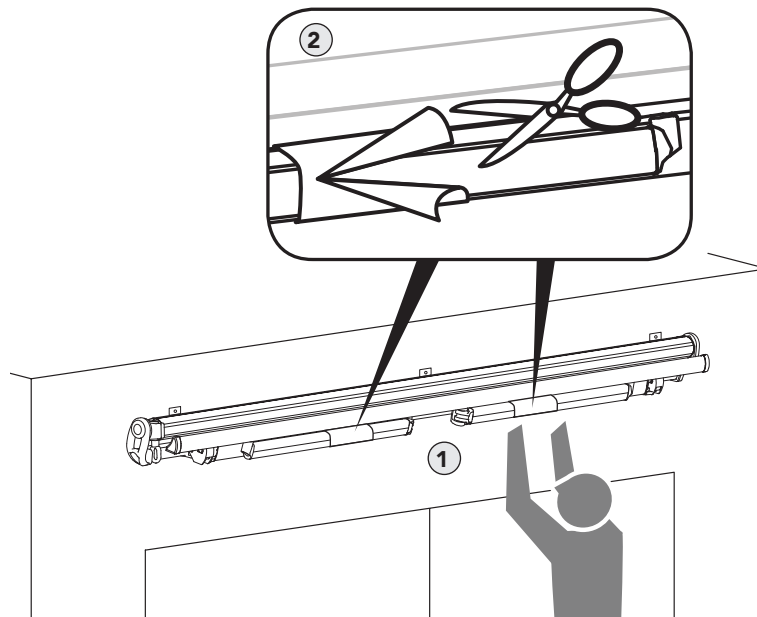

Fig 34

OPERATION

- ① Use the hand crank to open the awning fully then close it completely to test for proper operation.
- ② Use the hand crank and open the awning to desired extension.

CAUTION: To keep the fabric taut, always reserve a small portion of the awning fabric in the roller tube.

NOTE: The arms are not designed to be completely straight in the fully extended position.

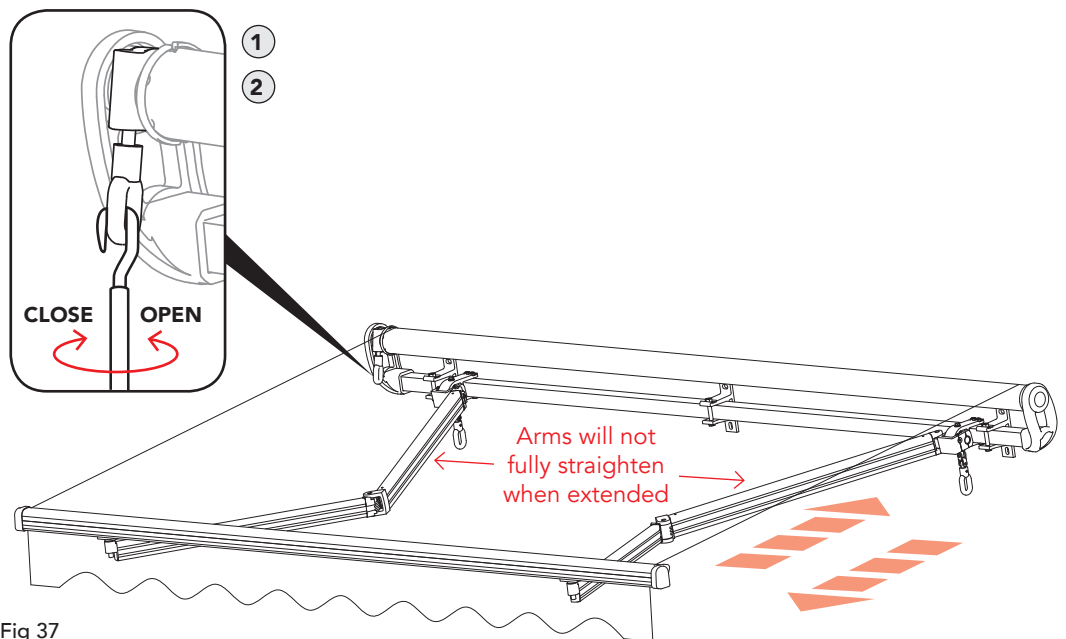

Fig 37

OPERATION

ADJUST AWNING PITCH

NOTE: All Advaning awning models come with the Easy Pitch™ adjustment system. 8-12ft awning models have two (2) Easy Pitch™ loops for adjustment.

- ① Open the awning.
- ② With the aid of a helper, support the front bar of the awning while another person adjusts the pitch of the awning using the hand crank and the Easy Pitch™ System.
- ③ Hook the hand crank through one of the Easy Pitch™ loops.
- ④ Turn the hand crank to adjust the awning pitch up and down.
- ⑤ Repeat the step on all Easy Pitch™ loops.
- ⑥ Use a level to check that the front bar is straight and leveled.

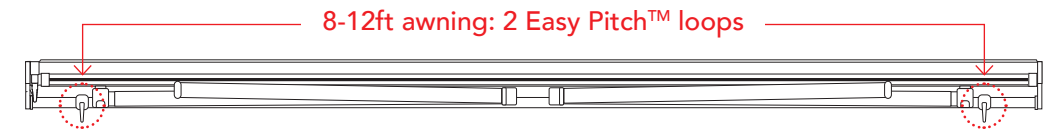

Fig 39

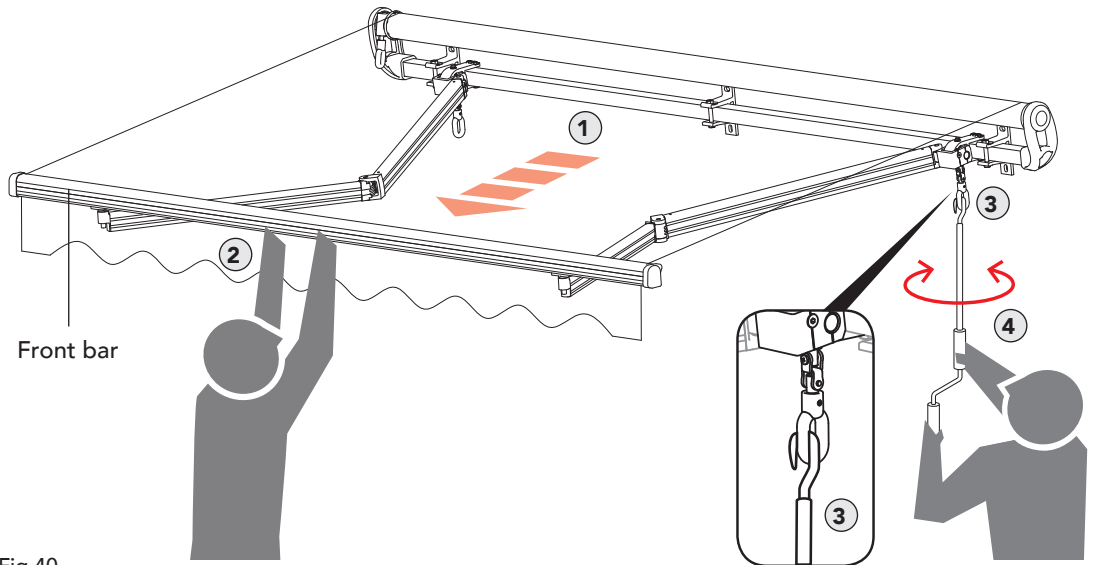

Fig 40

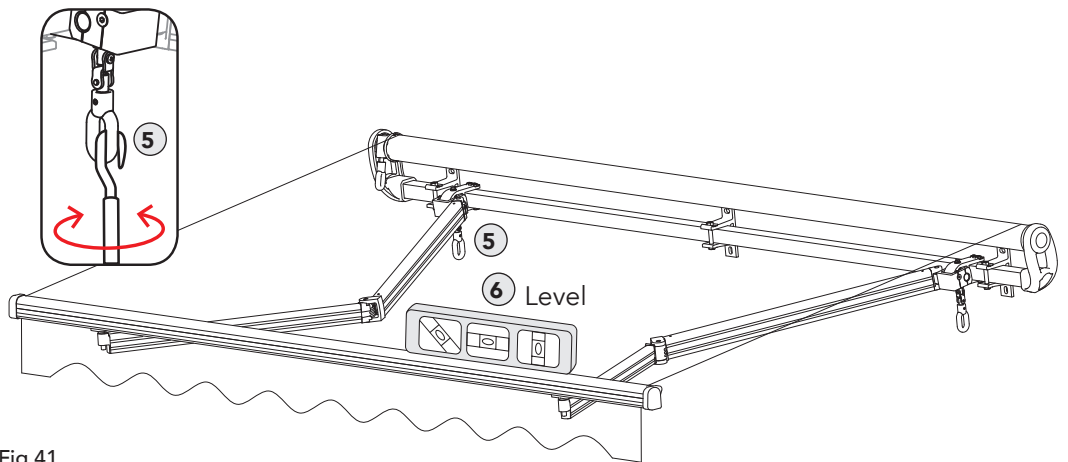
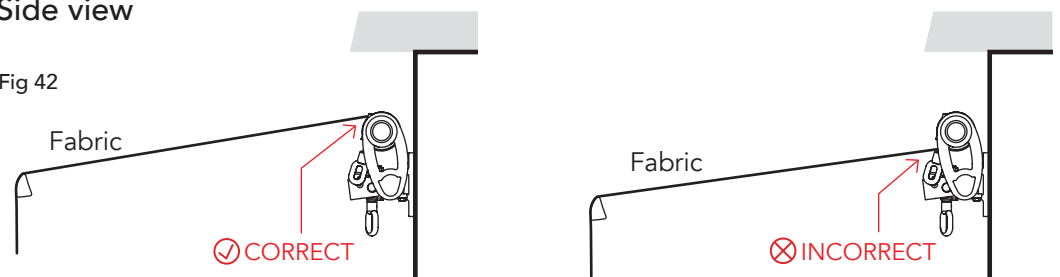

Fig 41

FABRIC ROLLING DIRECTION

Side view

Fig 42



MAINTENANCE

PROTECTING THE FABRIC FROM MILDEW

Allow the awning fabric to fully dry before retracting. Doing so will help prevent mildew from growing and prolong the life of the fabric.
If you must retract the awning while wet, open the awning as soon as the weather permits to allow the fabric to fully dry and remove any dirt deposits to preserve the fabric.

CLEANING THE FABRIC

Cleaning the awning regularly with mild soap and water will extend the life of the fabric and prevent the formation of mildew. It is necessary to prevent stains from becoming embedded into the fabric.
Remove the dust from the dry awning fabric by gently beating or brushing the fabric.

PROTECTING THE FRAME

Your awning contains powder-coating steel or aluminum and can last for many years. It is important to inspect the fasteners, connections and the condition of the metal components.

PROTECTING THE AWNING FROM HARSH WEATHER

The retractable awning is designed to provide protection from the sun and is not intended for rain, snow or extreme wind. Retract the awning to prevent damage from accumulated water, snow or from strong gusts of wind.

The fabric is water repellent and is not intended to protect against the water elements.

WARRANTY

LIMITED WARRANTY AND CUSTOMER SERVICE

LIMITED WARRANTY COVERS

Advaning warrants all Advaning original products, sold and installed within the 50 states of the United States, to be free of defects of materials and workmanship. This warranty only applies to the original owner or purchaser of the product and is only effective on a basis for sixty (60) months or five (5) years from the date of purchase. Any defects or issues presented to Advaning within the warranty period will be handled by Advaning Customer Service within a reasonable time.

Entire awning framework, including extruded and die cast component parts, springs and cables are covered under the limited warranty. Should the purchaser notify Advaning within the twelve (12) months or one (1) year period from the date of the original purchase, defective component will be replaced in full or repaired by Advaning at no charge. All claims submitted after twelve (12) months or one (1) year but within sixty (60) months or five (5) years from the date of the original purchase, the defective component will be replaced upon the purchaser's payment of 1/60th of the full retail cost of the component for each month of use prior to the claim. Powder coated finishes and painted finishes are excluded and are NOT covered under this limited warranty.

ANY MODIFICATIONS OR ALTERATIONS TO THE PRODUCT WILL VOID THIS WARRANTY.

ADVANING, INCLUDING ITS SUBSIDIARIES AND AFFILIATES SHALL NOT BE RESPONSIBLE IN ANY MANNER WHATSOEVER FOR INJURY, DEATH OR DAMAGE TO PROPERTY AS A RESULT OF THE INTENTIONAL OR ACCIDENTAL MISUSED FOR PURPOSES FOR WHICH THE PRODUCT WAS NOT DESIGNED FOR.

WARRANTY LIMITATION AND EXCLUSION

The warranty will be in effect once the awning is fully paid for.

Advaning is not responsible for damages due to faulty modifications, installation, or re-installation.

Advaning assumes no liability for damage to the structure to which the awning is attached, or to the property located underneath the awning. This limited warranty does not cover damage from ice, snow, hail, high winds, vandalism, neglect, improper use, or any natural disasters. This limited warranty does not cover degradation due to salt corrosion, oxidation, and chipping or peeling of the paint.

WARRANTY

LIMITED WARRANTY AND CUSTOMER SERVICE

Problems and Warranty Claims

If you experience a problem with your Advaning product, please contact Advaning Customer Service over the phone **Monday through Friday 8:00AM – 5:00PM Pacific Standard Time at 1-855-574-0158 or email us at service@advaning.com**.

- Prior to contacting Advaning via phone or email for warranty claims, please have your model name/number, serial/lot number, original proof of purchase, and a description of difficulty experience ready for our Customer Service team. Most issues can be resolved over the telephone by our trained Customer Service representatives. If any issues arise that cannot be solved over the phone or email, Advaning will issue a Return Merchandise Authorization (“RMA”) number, and arrange replacement parts for you.

For more information on returning a RMA product, please see Advaning Return Policy or contact Advaning Customer Service Department at (855) 574-0158.

- All Work will be carried out by Advaning or its authorized agents and will not extend the warranty coverage period beyond the sixty (60) months from the original date of purchase. Any work done by a third party or non-authorized Advaning agent will void this warranty.

THIS WARRANTY IS EXCLUSIVE AND IS IN LIEU OF ANY AND ALL OTHER WARRANTIES, EXPRESSED OR IMPLIED. NO IMPLIED WARRANTIES OF MERCHANTABILITY OR FITNESS FOR A PARTICULAR PURPOSE ARE GIVEN, ANY AND ALL LIABILITY FOR BREACH OF ANY IMPLIED WARRANTY OR WARRANTY CREATED BY LAW IS DISCLAIMED.

Some states do not allow limitations on how long an implied warranty lasts, so the above limitation may not apply to you.

UNDER NO CIRCUMSTANCES SHALL ADVANING, INCLUDING ITS SUBSIDIARIES AND AFFILIATES BE LIABLE FOR INCIDENTAL OR CONSEQUENTIAL DAMAGES WITH RESPECT TO ECONOMIC LOSS, INJURY, DEATH OR PROPERTY DAMAGE, WHETHER AS A RESULT OF BREACH OF THIS WARRANTY, NEGLIGENCE OR OTHERWISE.

Some states do not allow the exclusion or limitation of incidental or consequential damages, so the above limitation or exclusion may not apply to you in whole or in part. This warranty gives you specific legal rights. You may also have other rights that vary from state to state.

WARRANTY

LIMITED WARRANTY AND CUSTOMER SERVICE

What is Not Covered by the Advaning Limited Warranty

This warranty is non-transferable and does not cover product purchases from the initial buyer to a third party. This warranty does not cover incidental damages, such as loss of time, loss of use, or installation costs of defective, repaired or replaced product. This warranty does not cover product that has been damaged or rendered defective as a result of:

- (a) Neglect, abuse or misuse.
- (b) Modification of the original product.
- (c) Improper use or installation using products not manufactured by Advaning.
- (d) Service provided by anybody other than Advaning.
- (e) Abnormal mechanical or environmental conditions.
- (f) Unusual physical or electrical stress -including failure or fluctuation of electrical power, lighting, static electricity, fire, tornadoes, or other natural disasters.

Shipping Damage Claim:

On the occasion of a damage claim, the end user must contact Advaning and the delivering freight carrier within 3 days of signing for the delivery in order to make a claim. Failure to report freight damage and missing parts in a timely manner and in accordance to the carrier's guidelines may result in you incurring all costs.

Likewise, there are 7 days to report missing parts to Advaning.

For more information, please contact the corporate office.

Advaning Customer Service Center
Toll Free (US): (855) 574-0158
Email: service@advaning.com
Monday through Friday
8:00 am to 4:00 pm (Pacific Standard Time)

CONTACT INFORMATION

Sales & Technical Questions: techsupport@advaning.com

Warranty Claim: service@advaning.com

Toll Free (US): 855-574-0158

Fax: 877-310-3832

West Coast: 12282 Knott Street, Garden Grove, CA 92841

East Coast: 151 Airport Drive, Westminster, MD 21157

www.advaning.com