

6Ft x 5Ft Palladium

(EN) METAL GARDEN SHED

(ES) COBERTIZO METÁLICO

(FR) ABRI DE JARDIN EN MÉTAL

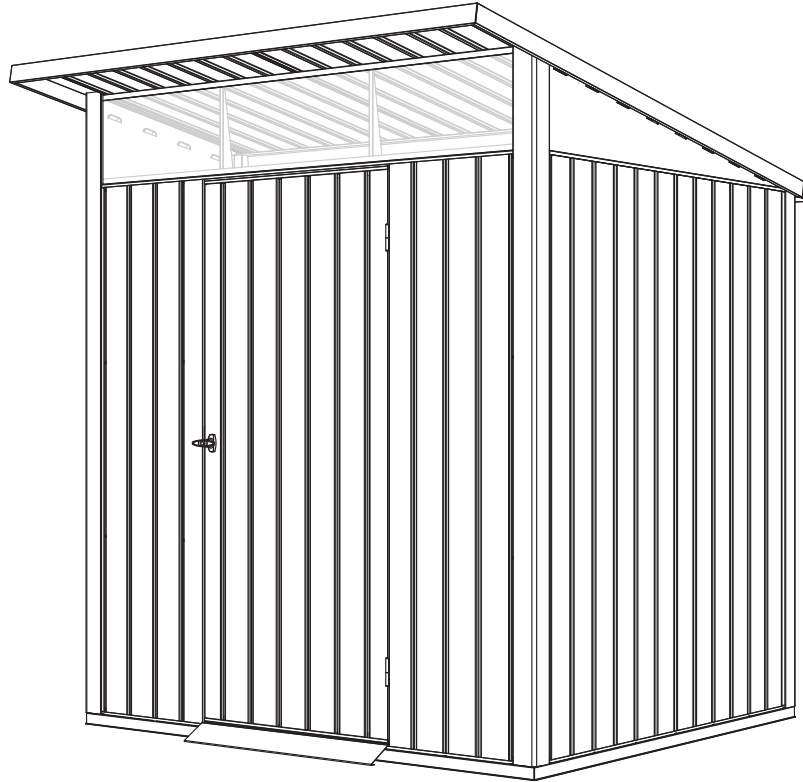

(EN) OWNER'S MANUAL /

Assembly Instructions '6Ft x 5Ft Palladium'

Size 6 Ft x 5 Ft / 1.9 m x 1.7 m (Approx.)

Ver: 0.0

Please thoroughly read the owner's manual before beginning the shed assembly.

Call us for any missing or damaged parts.

Do not return to the store.



You can watch the assembly videos on www.duramaxbp.com

Need Help? Comments or Suggestions

Call Customer Service Hotline.

(800) 483-4674

www.duramaxbp.com

WARRANTY ACTIVATION

Thank you for your purchase of DURAMAX shed. To activate your shed warranty, log on to our website and fill in the form under warranty activation.

www.duramaxbp.com/warranty.php

(ES) MANUAL DEL PROPIETARIO /

Instrucciones de montaje '6Pies x 5Pies Palladium'

Tamaño 6 Pies x 5 Pies / 1.9 Metros x 1.7 Metros (Aproximado.)

Ver: 0.0

Por favor a fondo lea el manual del dueño antes de comenzar la asamblea de cobertizo.

Llámenos para cualquier perder o partes dañadas.

No vuelva a la tienda.



Usted puede ver los videos de montaje en www.duramaxbp.com

necesita ayuda? Comentarios, Sugerencias?

La Línea Directa del Servicio del cliente.

(800) 483-4674

www.duramaxbp.com

ACTIVACIÓN DE GARANTÍA

Gracias por su compra de DURAMAX cobertizo usted. Para activar la garantía cobertizo, ingrese a nuestra página web y rellenar el formulario en la activación de la garantía.

www.duramaxbp.com/warranty.php

(FR) GUIDE D'INSTRUCTIONS /

Instructions de montage '6Pieds x 5Pieds Palladium'

Mesures 6 Pieds x 5 Pieds / 1.9 Mètre x 1.7 Mètre (Approximativ.)

Ver: 0.0

Veillez lire attentivement le mode d'emploi avant de commencer l'assemblage de remise.

Appelez-nous pour toute les pièces manquantes ou endommagées.

Ne pas retourner au magasin.



Vous pouvez regarder les vidéos de montage sur www.duramaxbp.com

a besoin d'aide? Commentaires, suggestions?

Hotline service client.

(800) 483-4674

www.duramaxbp.com

ACTIVATION DE LA GARANTIE

Merci pour votre achat de DURAMAX hangar. Pour activer la garantie de votre hangar, connectez-vous sur notre site et remplir le formulaire sous activation de la garantie.

www.duramaxbp.com/warranty.php

(EN) Your Total Solution To Maintenance Free Storage Sheds.

- Tall Walk in Shed
- Quick & Easy Assembly
- Ridge Reinforced Walls
- Snow load tested max. 20lbs/sq.foot
- Available in Various Sizes

(ES) Su solución total para mantenimiento de cobertizos de almacenamiento gratuito.

- Se puede estar de pie en su interior
- Montaje fácil y rápido
- Paneles corrugados reforzados.
- Carga de nieve probado max. 20LBS/sq.Foot
- Varios tamaños disponibles

(FR) Votre solution pour un abri de jardin sans entretien.

- Promenade debout dans l'abri
- Assemblage rapide & facile
- Murs à arête renforcé
- Charge de neige testé max. 20lbs/sq.Foot
- Disponible en différentes dimensions

(EN) Building Dimensions :

Approximate Size	Storage		Exterior Dimension				Interior Dimension		Door Opening		
	Area	Volume	Base Dimension		Roof Edge to Edge		Wall to Wall				
6 Ft x 5 Ft	34.4Sq.Ft	210 Cu.Ft	inch		cm		inch		cm		
			Width	76 1/2	194.5	78 1/8	198.6	75 1/8	190.9	30 1/2	77.5
1.9 m x 1.7 m	3.2 Sq.m	5.9 Cu.m	inch		cm		inch		cm		
			Depth	66 5/8	169.3	77 3/8	196.5	65 1/4	165.7		
			Height			90 1/8	228.9	74	188	71 5/8	181.9

(ES) Dimensiones del edificio

El Tamaño a aproximado	Área de almacenaje		Dimensión exterior				Dimensión interior		Abertura de la puerta		
	Área	Volume	Dimensión de la base		Borde de la azotea al borde		pared a pared				
6 Pies x 5 Pies	34.4 Pies cuadrados	210 Pies Cúbicos	Pulgada		cm		Pulgada		cm		
			Anchura	76 1/2	194.5	78 1/8	198.6	75 1/8	190.9	30 1/2	77.5
1.9 Metros x 1.7 Metros	3.2 Metros cuadrados	5.9 Metros Cúbicos	Pulgada		cm		Pulgada		cm		
			Profundidad	66 5/8	169.3	77 3/8	196.5	65 1/4	165.7		
						90 1/8	228.9	74	188	71 5/8	181.9

(FR) Dimensions du bâtiment :

Taille approximative	Stockage		Dimension extérieure				Dimension intérieure		Ouverture de porte		
	Secteur	Volume	Dimension de base		Toit de bord au bord		Mur à mur				
6 Pieds x 5 Pieds	34.4 Carré pieds	210 Pieds cube	pouce		cm		pouce		cm		
			Largeur	76 1/2	194.5	78 1/8	198.6	75 1/8	190.9	30 1/2	77.5
1.9 Mètre x 1.7 Mètre	3.2 Mètre carré	5.9 Mètre cube	pouce		cm		pouce		cm		
			Profondeur	66 5/8	169.3	77 3/8	196.5	65 1/4	165.7		
						90 1/8	228.9	74	188	71 5/8	181.9

(EN) Duramax Storage Shed Limited Twenty Five Year Warranty

U.S. Polymer Inc. will send a replacement part free of charge, in the event of material defects and or workmanship for a period of fifteen years from the date of purchase.

This warranty is extended only to the original purchaser. A purchase receipt or other proof of date of original purchase will be required before warranty service is rendered. In no event shall we pay the cost of flooring, labor, installation or any other costs related thereto.

This warranty only covers failures due to defects in material or workmanship which occurs during normal use and does not extend to color change arising due to normal weathering or to damage resulting from misuse or neglect, commercial use, failure to follow assembly instructions and the owner's manual (including proper anchoring of the shed), painting, forces of nature and other causes which is beyond our control.

Claims under this warranty must be made within the warranty period by calling 1-800-483-4674 or mail in a dated sales slip and clear photograph of the part to:

U.S. Polymers Inc. 1057 S. Vail Ave Montebello, CA 90640, United States of America.

We reserve the right to discontinue or change components. If a component has been discontinued or is not available,

U.S. Polymers, Inc. reserves the right to substitute a component of equal quality as may be compatible.

Limits and Exclusions

There are no express warranties except as listed above. The warrantor shall not be liable for incidental or consequential damages resulting from the use of this product, or arising out of any breach of this warranty. All express warranties are limited to the warranty period set forth above. Some states do not allow the exclusion or limitation on how long an implied warranty lasts, so the above limitations may not apply to you.

This warranty gives you specific legal rights and you may also have other rights which vary from state to state or country to country.

(ES) Cobertizo para Herramientas Duramax Garantía Limitada durante a 25 años

U.S. Polymer Inc. enviará una pieza de recambio sin coste alguno en caso de defectos de fábrica o en los materiales durante un periodo de 15 años a partir de la fecha de adquisición.

Esta garantía se aplica únicamente al comprador original. Es necesario presentar un recibo u otra prueba de compra antes de prestar los servicios especificados en esta garantía. En ningún caso se sufragará el coste de la instalación de suelos, mano de obra, instalación o cualquier otro gasto relacionado.

Esta garantía cubre exclusivamente los defectos de fabricación o en los materiales que aparezcan durante el uso habitual y no se aplica a los cambios de color causados por la exposición normal a los elementos o a daños ocasionados por un uso inapropiado o negligente, usos comerciales, no seguir las instrucciones de montaje o el manual del propietario (incluyendo el correcto anclaje del cobertizo), aplicación de pintura, causas naturales o cualquier otra ajena a nuestro control.

Las reclamaciones cubiertas por la presente garantía pueden efectuarse dentro del periodo de garantía llamando al teléfono 1-800- 483-4674 o por correo postal con una prueba de compra fechada y una fotografía nítida de la pieza dañada a:

U.S. Polymers Inc. 1057 S. Vail Ave Montebello, CA 90640, United States of America.

Nos reservamos el derecho a abandonar la fabricación de un componente o cambiarlo. En caso de no continuar fabricando un componente o no estar éste disponible, U.S. Polymers, Inc. se reserva el derecho a sustituirlo por otro componente de idéntica calidad que sea compatible

Límites y Exclusiones

No existe ninguna garantía expresa más allá de las indicadas anteriormente. El garante no aceptará ninguna responsabilidad por daños incidentales o emergentes ocasionados por el uso de este producto o por cualquier infracción de esta garantía. Todas las garantías expresadas se aplican al periodo de garantía anteriormente señalado. Algunos estados no aceptan exclusiones o limitaciones en la duración de las garantías implícitas, por lo que las limitaciones anteriormente expresadas pueden no ser de aplicación para usted.

Esta garantía otorga derechos legales específicos. Usted puede disfrutar también de otros derechos que pueden ser diferentes para cada estado o país.

(FR) Duramax tárolók Garantie Restreinte de Vingt-cinq ans

U.S. Polymer Inc. remplacera sans frais toute pièce en cas de défaut de fabrication ou de matière pour une période de quinze ans (A compter de la date d'achat).

La garantie est seulement étendue à l'acheteur original. Une facture d'achat ou autre preuve confirmant la date de transaction sera exigée avant que le service de garantie vous soit accordée. Nous ne rembourserons aucun frais liés à l'achat des fondations, de main-d'oeuvre, d'installation ou tout autre cout extérieur à la garantie.

La garantie s'applique contre tous défauts de fabrication ou de matière dès lors que l'installation est conforme aux préconisations du fabricant décrites dans la notice d'assemblage, à l'exception d'une mauvaise utilisation, de l'usure, d'une décoloration liée aux intempéries, d'une utilisation commerciale et d'incidents matériels extérieurs concernant le dit produit.

Toutes réclamations doivent être faites durant la période de garantie en téléphonant au 1-800-483-4674 ou en expédiant une facture d'achat datée et une photographie de la pièce à:

U.S. Polymers, Inc. 1057 S. Vail Ave, Montebello, CA 90640, United States of America.

Nous nous réservons le droit d'annuler ou de changer les pièces si l'une des pièces a été arrêtée ou n'est plus disponible. U.S. Polymers Inc. se réserve le droit de changer une pièce de qualité égale à la pièce d'origine.

Limitation et Exclusions

Il n'y a d'autre garantie exceptée celle mentionnée ci-dessus. Le garant n'est pas responsable des dégâts matériels ou des accidents consécutifs à une installation non conforme aux dispositions légales et réglementaires du pays de mise en service. En aucun cas, cette garantie ne donne droit à des indemnités ou à des dommages et intérêts. Toutes garanties sont limitées pour une période mentionnée ci-dessus certains pays ne permettent pas la limitation et l'exclusion concernant la durée de garantie, ceci pourrait donc ne pas s'adresser à vous.

Cette garantie vous donne des droits légaux spécifiques et vous pourriez aussi avoir d'autres droits qui varient d'un pays à l'autre.

(EN) SAFETY & PRECAUTIONS

For your own safety, please read and follow these instructions during the shed assembly.

Before You Begin...

1. Check your local building codes regarding footings, location, etc.
2. Select a site that allows enough working space around the shed.
3. Determine building foundation and anchor system.
4. Read and understand the Owner's manual enclosed in the package.
5. Follow all directions and dimensions thoroughly.
6. Follow the steps given in the manual carefully for correct assembly.
7. Make sure all parts are present before you start assembling.
8. **BE SAFE** : Follow safety instructions and avoid injury.
(See inside page).
9. **GROUND MUST BE EVEN** : Make sure the foundation frame lies flat on the ground. If the earth bed is uneven, remove sod and other debris and level it with a flat shovel.
10. Separate contents of the carton by the part number and review the list. Be sure you have all the necessary parts for your shed. Refer Owner's manual for part list.





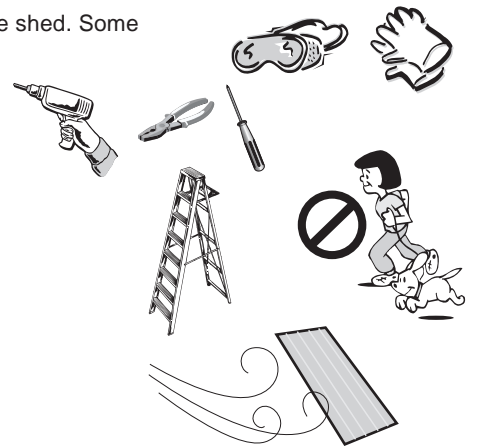

Safety First !

1. Always wear work gloves, long sleeves and eye protection during assembly of the shed. Some pieces of the shed contain sharp edges and can cause injury.
2. Be cautious with the tools used for the assembly of the shed. Familiarize yourself with the operation of all the power tools.
3. Children and pets should be kept away from the assembly site to avoid any distractions and accidents.
4. When using a step ladder, make sure it is on even ground and fully open with the safety latch in place. Never concentrate your full weight on the roof or any part of the shed.
5. Do not attempt to assemble the shed on a windy day. Shed panels can be whipped across by the wind making the worksite difficult and dangerous.



Important

-  Wear eye protection when using any form of power tools. Do not use voltage power tools in a wet or damp environment to avoid electric shock.
-  Do not use any part of the shed as a means of personal support while attaching components during assembly.
-  **The shed must be constructed on a solid base foundation.** A concrete pad or a large size concrete patio stone squares is recommended for suitable floor base. Make sure it is firm and level and will allow drainage away from the site. The base foundation should be at least 4 inches (100mm) larger than the shed dimensions. Please refer to the front page of your owner's manual for the exterior dimensions of the shed. **Manufacturer is not responsible for the choice and construction of the foundation.**
For a concrete pad base, prepare a level bed for a firm footing layer of crushed stone. The concrete pad should then be poured to a thickness of 4 inches (100mm) to 5 inches (125mm). Allow to dry thoroughly for at least 48 hours.
-  Your shed must be firmly anchored to the concrete pad or large concrete patio stone squares, to help protect against damage in high winds.

Care & Maintenance

Although this unit does not require any maintenance, care should be taken to prolong the life of your shed. It is for once time assembling and set up, no purpose of re-using.

ROOF : Keep roof clean of leaves and snow with long handled, soft bristled broom. Heavy amounts of snow on the roof can damage the shed making it unsafe. **"Do not walk on roof surfaces! Risk of falling!"**.

WALLS : Do not rest any object against the wall panels of the shed.

DOORS : Keep doors closed to prevent wind damage.

FASTENERS : Regularly check your shed for loose screws, bolts, nuts, etc. And retighten them as necessary.

MOISTURE : With changing temperatures, condensation will accumulate inside the shed. Good ventilation will help in regulating and avoid moisture.

TIP : A noncorrosive caulking is helpful to seal the shed.



DO NOT store Inflammable, Hazardous and Swimming pool chemicals in your building. Combustibles and corrosive must be stored in air tight containers.
Enforce **NO SMOKING.**



(ES) SEGURIDAD Y PRECAUCIONES

Para su propia seguridad, lea y siga las instrucciones durante el ensamblaje del cobertizo.

Antes de comenzar ...

1. Consulte los códigos de construcción locales relativos a cimentación, localización etc.
2. Seleccione un sitio que permite suficiente espacio para trabajar alrededor de la nave.
3. Determine la fundación de la construcción y sistema de anclaje.
4. Lea y entienda el manual de instrucciones incluido en el paquete.
5. Siga las indicaciones y dimensiones exhaustivamente.
6. Siga los pasos indicados en el manual para un montaje correcto.
7. Asegúrese de que no le falte ninguna pieza antes de empezar el montaje.
8. SEA SEGURA : Para evitar lesiones siga las instrucciones de seguridad.(Véase pagina interior).
9. El SUELO DEBE SER NIVELADO : Asegúrese de que el marco de la base quede plano en el suelo .Si la base del suelo esta desnivelado se recomienda que quite césped y otros escombros y lo nivele con una pala plana.
10. Disponga del contenido de la caja según numeración de las partes , revisando la lista.Asegúrese de que no le falte ninguna pieza para el montaje de su cobertizo. Consulte el manual del propietario para revisar el nombre de las piezas.



Safety Primero !

1. Use siempre guantes de trabajo, mangas largas protección ocular durante el montaje de la nave . Algunas piezas de la nave tienen bordes afilados y pueden causar lesiones.
2. Tenga cuidado con las herramientas utilizadas para el montaje de la nave. Familiarícese con el funcionamiento de todas las herramientas eléctricas.
3. Los niños y los animales domésticos deben mantenerse alejados de las instalaciones de ensamblaje para evitar cualquier distracción o accidente.
4. Cuando se utiliza una escalera de tijera , asegúrese de que este sobre un fondo plano y completamente abierto con el pasador de seguridad en su lugar. Nunca concentre todo su peso sobre el techo o cualquier parte de la nave.
5. No intente montar el cobertizo durante un día ventoso. Los paneles de cobertizo pueden ser azotados a través por el viento que hace las obras difíciles y peligrosas.

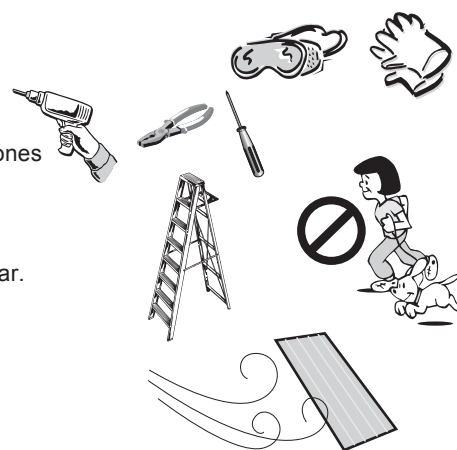

Importante

- Use protección ocular cuando utilice cualquier tipo de herramientas eléctricas. No utilice herramientas de tensión en un ambiente húmedo o mojado para evitar descargas eléctricas.
- No utilice ninguna parte de la nave como un medio de apoyo personal mientras coloca los componentes durante el montaje.
- La vertiente se debe construir en una fundación sólida.** Un cojín concreto o los cuadrados concretos del tamaño grande de una piedra del patio se recomiendan para la base conveniente para el suelo. Asegúrese de que sea firme y llana y que permita drenaje lejos del sitio. La fundación baja debe ser por lo menos de 4 pulgadas (100mm) más grande que las dimensiones de la vertiente. Refiera por favor a la página delantera del manual de su dueño para las dimensiones exteriores de la vertiente. **El fabricante no es responsable de la opción y de la construcción de la fundación.**
Para una base concreta del cojín, prepare una cama llana para una capa de pie firme de la piedra machacada. El cojín concreto se debe entonces verter a un grueso de 4 pulgadas (100mm) a 5 pulgadas (125mm). Permita secarse a fondo por lo menos 48 horas.
- Su cobertizo debe ser firmemente anclado al bloc de concreta o cuadrados(plazas) de piedra de patio g randes concretos, ayudando a proteger contra el daño del viento fuertes.

Cuidado & Mantenimiento

Aunque esta unidad no requiere mantenimiento, se debe tener cuidado para prolongar la vida de su caseta. Es tiempo por una vez ensamblar y configurar, sin propósito de volver a usar.

CUBIERTA: Mantenga el techo limpio de hojas y la nieve con mango largo y cerdas suaves escoba. Grandes cantidades de nieve en el techo pueden dañar el cobertizo y hacer peligrosa. **“No camine sobre superficies de techo! Riesgo de caer”!**

PAREDES: No apoye ningún objeto contra los paneles de la pared del cobertizo.

PUERTAS: Mantenga las puertas cerradas para prevenir daños por el viento.

SUJETADORES: Verifique periódicamente su cobertizo para los tornillos, pernos, tuercas, etc, y volver a apretarlo en caso necesario.

HUMEDAD: Con los cambios de temperatura, la condensación se acumulará en el interior del cobertizo. Una buena ventilación ayudará en la regulación y evitar la humedad.

SUGERENCIA: Un sellador no corrosivo ayudaría a sellar la nave.



No guarde productos químicos inflamables, peligrosos y piscina en el edificio.
Combustibles y corrosivos deben guardarse en recipientes herméticos un aire.
No aplicar el fumar.



(FR) SÉCURITÉ ET PRÉCAUTIONS

Pour votre propre sûreté, svp lisez et suivez ces instructions avant et pendant le montage.

Avant de commencer...

1. Vérifiez vos codes de la construction et de l'habitation concernant la pose, l'emplacement, etc.
2. Choisissez un site qui laisse assez d'espace de travail autour de l'abri.
3. Déterminez la surface de l'abri et fixez les système d'ancrage aux fondations.
4. Lisez et analysez le manuel de l'abri glissez dans le paquet.
5. Suivez scrupuleusement toutes les consignes et les dimensions.
6. Suivez les étapes scrupuleusement les étapes de montage afin de monter correctement votre abri.
7. Assurez-vous que toutes les pièces sont présentes avant de débiter le montage.
8. ATTENTION : Suivez les consignes de sécurité afin d'évitez tous dommages physiques ou corporels.
9. LA SURFACE DE POSE DOIT PLANE ET DE NIVEAU : Assurez-vous que les fondations sont posées sur un sol plan et de niveau. Si le lit de sol est inégal, enlevez le gazon et autres débris et nivelez-la avec une pelle.
10. Classez l'ensemble des pièces par numéro et confrontez -les à la liste de la notice. Soyez sûr que vous avez toutes les pièces nécessaires pour le montage de votre abri.



Safety Premier !

1. Portez toujours des gants de travail, de longues manches et des lunettes de protection des yeux pendant le montage de l'abri. Quelques morceaux de l'abri contiennent des bords agressifs et peuvent causer des dommages.
2. Soyez prudent avec les outils utilisés pour le montage de l'abri. Familiarisez-vous avec le fonctionnement de toutes machines-outils.
3. Ne laissez pas les enfants et les animaux jouer autour de l'abri lors du montage, afin d'éviter tous risques d'accidents.
4. Si vous utilisez une échelle, assurez-vous qu'elle soit posée sur un sol plan et de niveau. Ouvrez-la entièrement et assurez-vous que les verrous de sécurité des charnières sont bien enclenchés. Ne jamais marcher sur le toit ou tout autre partie de l'abri.
5. N'essayez pas d'assembler l'abri en cas de vent fort. Les panneaux de l'abri peuvent s'envoler rendant le montage dangereux.

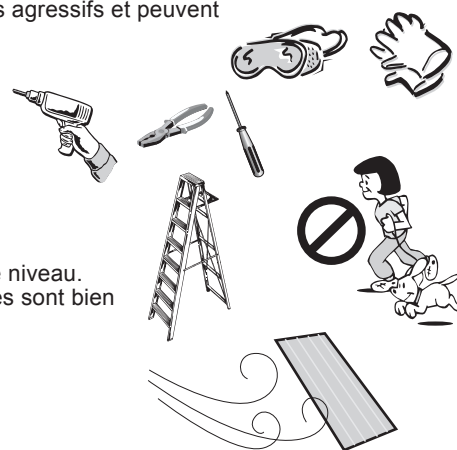

Important

- Portez des lunettes de protection lors de l'utilisation de machine-outils. N'utilisez pas de machine-outils électriques dans un environnement humide afin d'éviter tous chocs électriques.
- N'utilisez pas de composant de l'abri en tant qu'échelle lors du montage de l'abri.
- L'abri doit être construit sur des fondations solides.** Une dalle de béton armé ou de dalles de béton de grandes dimensions (100x100 cm minimum) est recommandé. S'assurer qu'elle est plane et de niveau et permettra le drainage de l'eau. La dalle devra faire 10 cm de plus que les dimensions extérieures de l'abri. Veuillez vous référer à la première page de votre manuel pour les dimensions extérieures de l'abri. **Le fabricant n'est pas responsable du choix et de la construction des fondations.**
Pour une dalle en béton, préparer une couche de graviers de niveau. La dalle doit faire entre 10 et 12.5 cm. Laissez sécher 1cm pour 10 jours.
- Votre abri doit être fermement ancré à la dalle, pour se protéger contre les risques de dommages liés aux vents forts.

Soin et entretien

Bien que cette unité n'exige aucun entretien, le soin devrait être pris afin de prolonger la vie de votre hangar. il est temps pour une fois le montage et mis en place, aucun objectif de réutilisation.

TOIT : Le toit doit être nettoyé avec un balai mou et à long manche afin de le débarrasser des feuilles et de la neige. Une grande quantité de neige sur le toit peuvent endommager le hangar le rendant peu sûr.

"Ne pas marcher sur des surfaces de toit ! Risque de tomber! "

MURS : Ne mettez aucun objet contre les panneaux de mur

PORTES: Assurez-vous que les portes sont fermées afin d'empêcher les risques de dommages liés aux vents forts

PIÈCES DE FIXATION : Examinez régulièrement votre les vis, boulons, écrous, de votre abri. En cas de doute resserez-les

HUMIDITÉ : Avec les températures changeantes, la condensation s'accumulera à l'intérieur de l'abri. La bonne ventilation aidera à l'évacuation de l'humidité.

CONSEIL : Un calfeutrage non corrosif est utile afin de renforcer la durée de vie de l'abri.



NE pas stocker de produits chimiques inflammables, dangereux et piscine dans votre immeuble. Les combustibles et les produits chimiques doivent être stockés dans des armoires étanches et isolées. N'appliquer fumeur.





(EN) Note : Before starting installation, please refer Safety & Precautions.

(ES) Pozor : Antes de comenzar la instalación, consulte Seguridad y Precauciones.

(FR) Note : Avant de commencer l'installation, référez-vous svp au chapitre Sécurité et Précautions.

(EN) Tools You Will Need

Hand Gloves
Cordless Drill - Philips Head
Screw driver
Carpenter's Square
Eye Protector
8' Step Ladder
Box Spanner-8 mm
Level - 3ft.
Tape Measure

(ES) Equipar con herramienta Usted Necesitará

Guantes de la mano
Taladro inalámbrico - cabeza Philips
Destornillador
Carpinteros Plaza
Protector de Ojo
Escalera de 8 '
Llave de tuerca de caja-8mm
Nivelan - 3ft.
Cinta métrica

(FR) Outils dont vous aurez besoin(non fournis)

Gants
Perceuse sans fil – Tête Philips
Tournevis
Equerre
Lunettes de protection
Escabeau
Clé de serrage de boîte-8mm
Niveau - 3ft.
Mètre à ruban

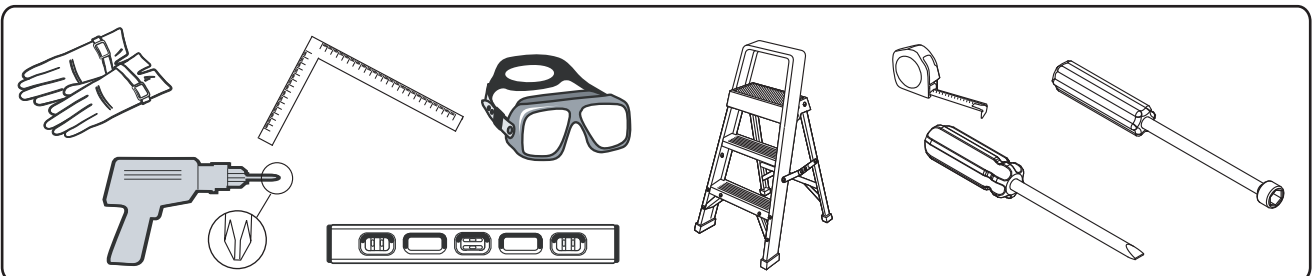

(EN) Parts List
(ES) La Lista de partes
(FR) Liste des pièces



(EN) Check all parts prior to installation.
(ES) Revisar todas las partes antes de la instalación
(FR) Vérifier toutes les pièces avant d'installer.

(EN) PROFILES (ES) PERFILES (FR) PROFILES	(EN)CODE (ES)CODE (FR)CODE	(EN)QTY (ES)QTY (FR)QTÉ
	A001	1
	A002	4
	A003	2
	A004	2
	A005	2
	A006	2
	A007	1
	A008	1
	A009	2
	A010	1
	A011	1
	A012	1
	A013	1
	A014	1
	A015	2
	A016	1
	A017	1
	A018	1
	A019	1
	A020	1
	A021	1
	A022	1
	A023	1

(EN) PROFILES (ES) PERFILES (FR) PROFILES	(EN)CODE (ES)CODE (FR)CODE	(EN)QTY (ES)QTY (FR)QTÉ
	A024	1
	A025	1
	A026	2
	A027	2
	A029	1
	A030	1
	A032	1
	A033	1
	A034	1
	A036	2
	A037	4
	A038	1
	A039	1
	A041	2
	A056	1

(EN) ACCESSORIES (ES) ACCESORIOS (FR) ACCESSOIRES		
(EN) PROFILES (ES) PERFILES (FR) PROFILES	(EN)CODE (ES)CODE (FR)CODE	(EN)QTY (ES)QTY (FR)QTÉ
	A042	1
	A043	1
	A044	1
	A045	1
	A047	1
	A048	1
	A049	1
	A050	1
	A054	119
	A055	14
	F1	14
	S2	46
	S8	14

(EN) Exploded View
(ES) El Panorama estallado
(FR) Vue Explosée

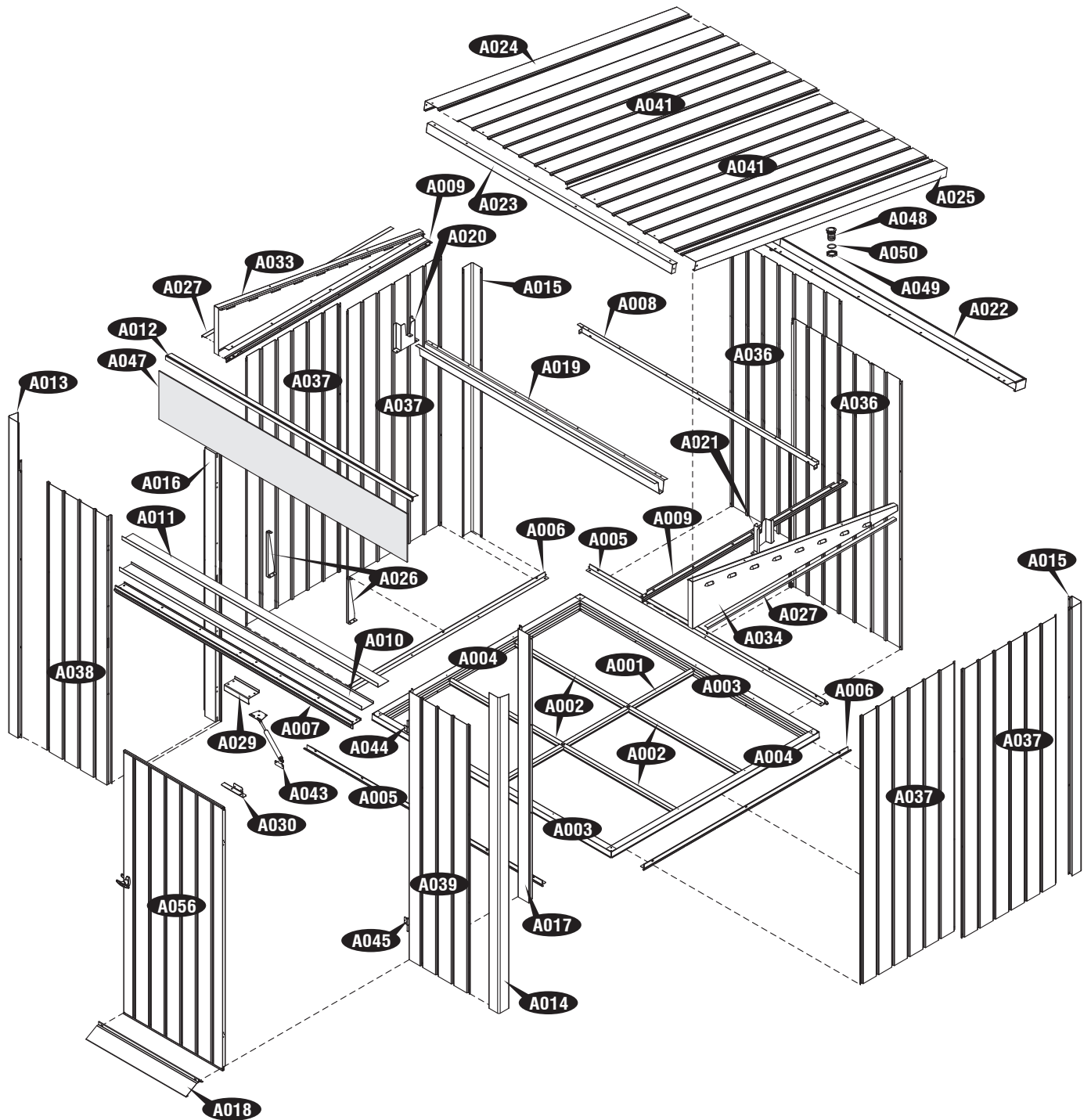
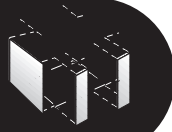

(EN) Quick Start
 (ES) Inicio rápido
 (FR) Démarrage rapide

- 
- 1 → # 9-11
 - 2 → # 12-13
 - 3 → # 14-22
 - 4 → # 23-32
 - 5 → # 35-39

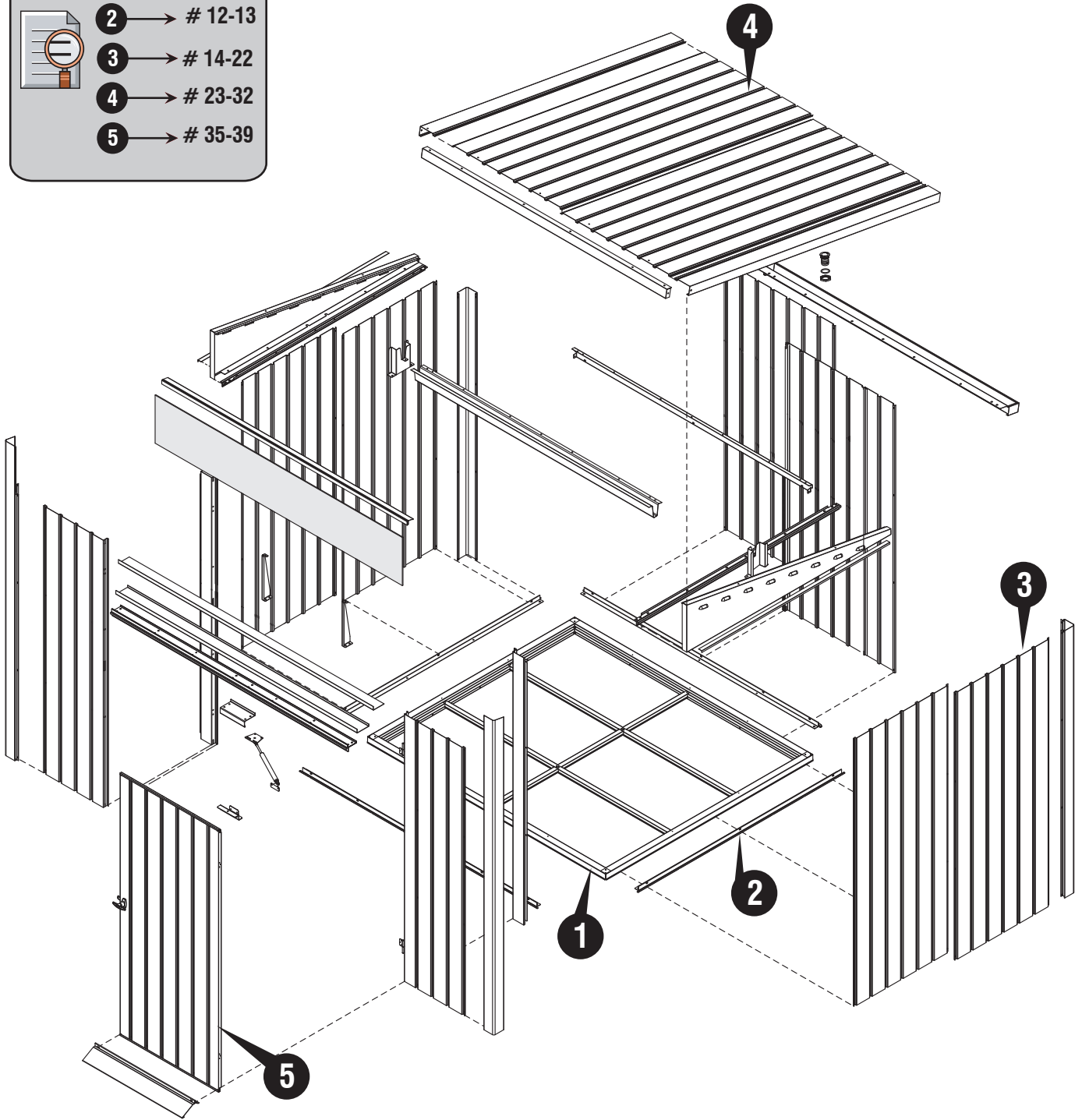



1

(EN) Foundation
(ES) La base
(FR) Fondation



- (EN)** 1. It is important that these instructions are followed step by step.
 2. All parts are clearly marked and care should be taken to use the correct one.
 3. Don't install under windy conditions.
 4. If you are building the shed against a wall, build it 2.5 ft. away then slide it in. (Only for Duramax foundation & Wooden foundation)

(EN) Parts needed
(ES) Las partes necesitaron
(FR) Pièces nécessaires

(EN)CODE (ES)CODE (FR)CODE	(EN)QTY (ES)QTY (FR)QTÉ
A001	1
A002	4
A003	2
A004	2
S2	18

- (ES)** 1. es importante que estas instrucciones se sigan paso a paso.
 2. Todo pone piezas son marcados claramente y cuidan debe ser tomado para usar el corrige uno.
 3. No instale las condiciones abajo de mucho viento.
 4. Si usted está construyendo la cubierta contra una pared, construirlo 2.5 pies de distancia y deslícela hacia dentro. (esto sólo es aplicable para la Fundación de Duramax Fundación madera).

- (FR)** 1. Il est important que ces instructions soient suivies pas à pas.
 2. Toutes les pièces sont clairement identifiées et il faut veiller à utiliser la bonne.
 3. Ne pas installer sous conditions de vent.
 4. Si vous construisez le hangar contre un mur, le construire à un écart de 2,5 pi, puis le glisser. (ceci n'est applicable pour la Fondation Duramax Fondation en bois).



(EN) Levelled Solid Floor Surface Required
(ES) Nivelado piso sólido superficie requerida
(FR) Surface de plancher solide nivelée requise

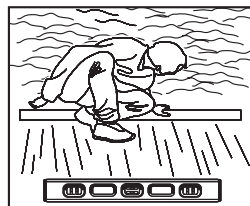

(EN) DuraMax must be installed on a level wooden platform or a level concrete foundation, that has an outside dimension of 72" x 78 1/2"(1828mm x 1995mm).

(ES) DuraMax debe instalarse en una plataforma de madera nivelada o una base de hormigón nivelada, que tenga una dimensión exterior de 72" x 78 1/2"(1828mm x 1995mm).

(FR) DuraMax doit être installé sur une plate-forme en bois de niveau ou une fondation en béton de niveau, qui a une dimension extérieure de 72" x 78 1/2"(1828mm x 1995mm).

(EN) Set the Torque limit of your Screw drill to #3 or #4 to ensure the screws do not strip the Metal reinforcements.

(ES) Establecer el límite de par de su taladro tornillo de # 3 y # 4 para asegurar los tornillos no tira los refuerzos metálicos.

(FR) Réglez la limite de couple de votre perceuse Vis à n # 3 ou n # 4 pour s'assurer que les vis ne supprime pas les renforts métalliques.



(EN) Note : For plywood cut size, refer to page 34.

(ES) Pozor : Para contrachapado cortado tamaño, consulte la página 34.

(FR) Note : Pour le contreplaqué dimensions, reportez-vous à la page 34.

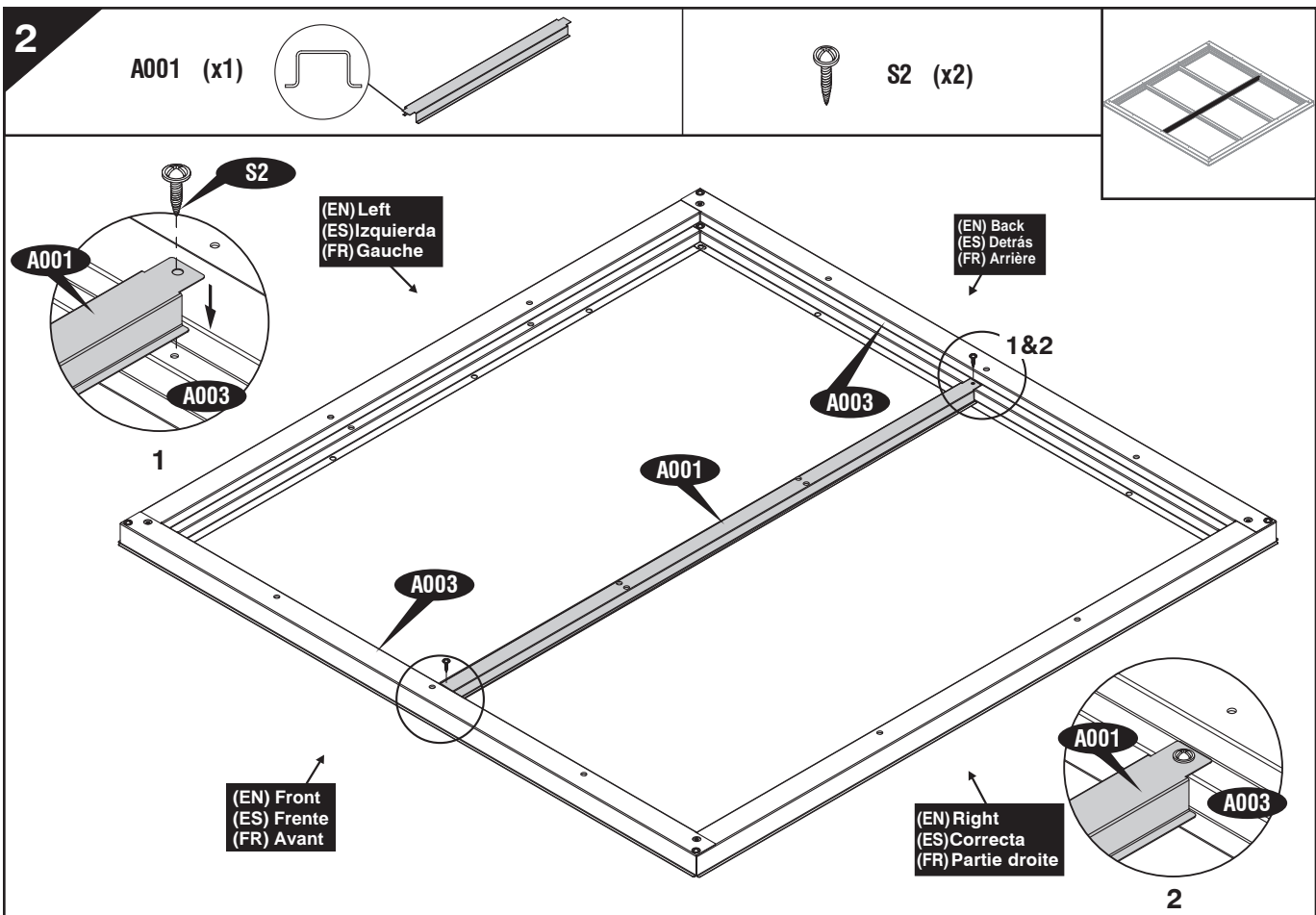
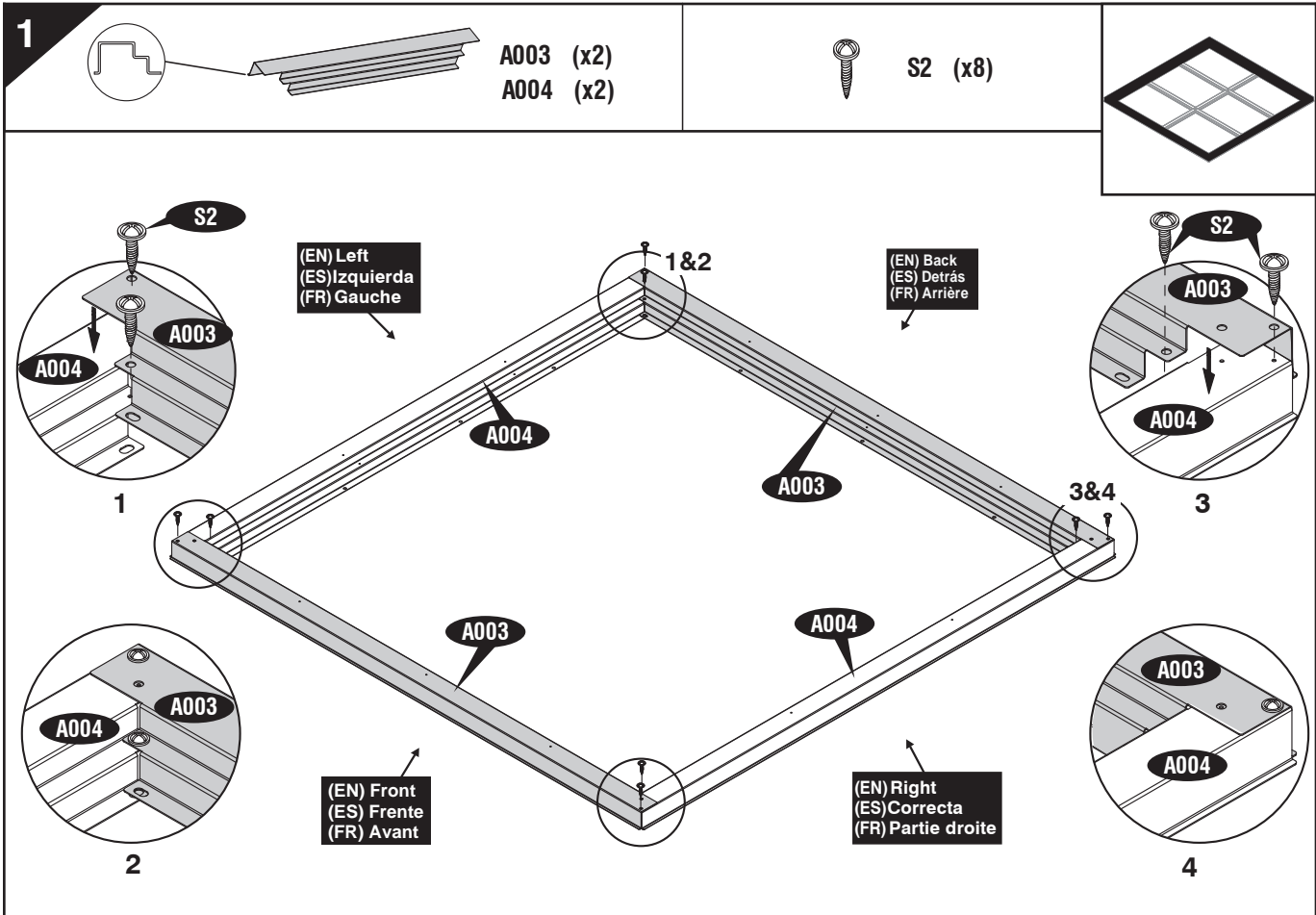

3

A002 (x4)

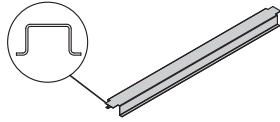

S2 (x8)

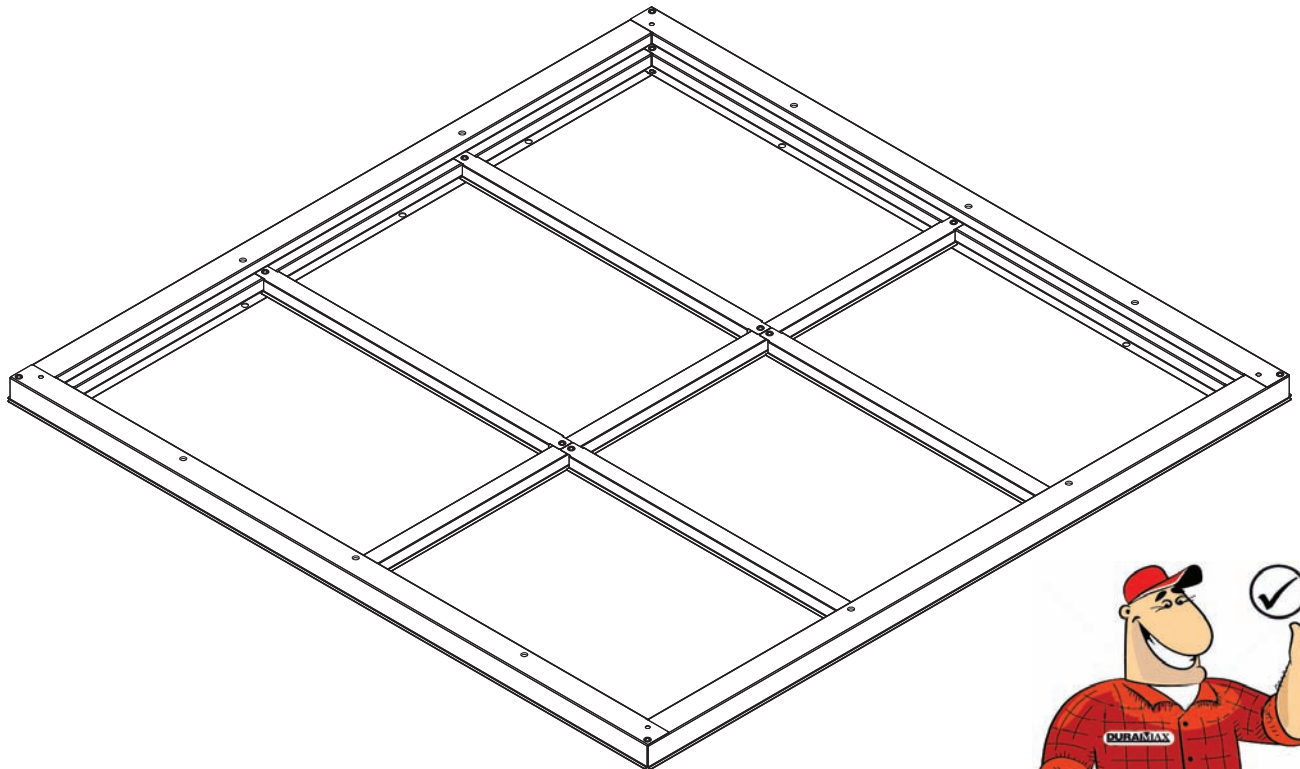
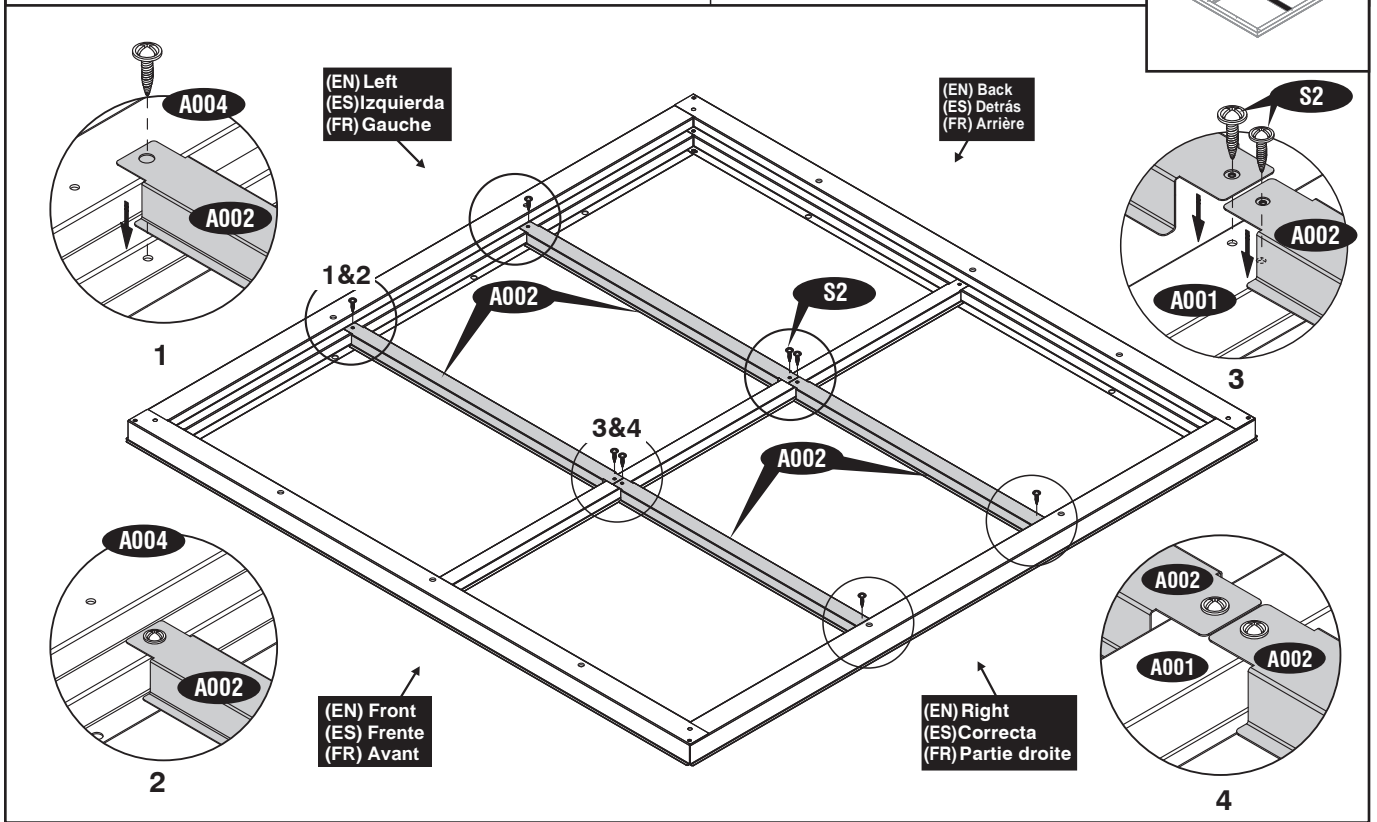
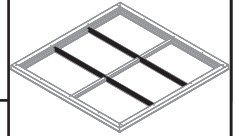



2

(EN) Base Frame
 (ES) Armazón de la base
 (FR) Profiles de base



(EN) Parts needed
 (ES) Las partes necesitaron
 (FR) Pièces nécessaires

(EN)CODE (ES)CODE (FR)CODE	(EN)QTY (ES)QTY (FR)QTÉ
A005	2
A006	2
S2	14



(EN) Note: Take care of sharp edges.
 (ES) Nota: Cuidado de las orillas agudas.
 (FR) Note: Prenez soin des arêtes vives.

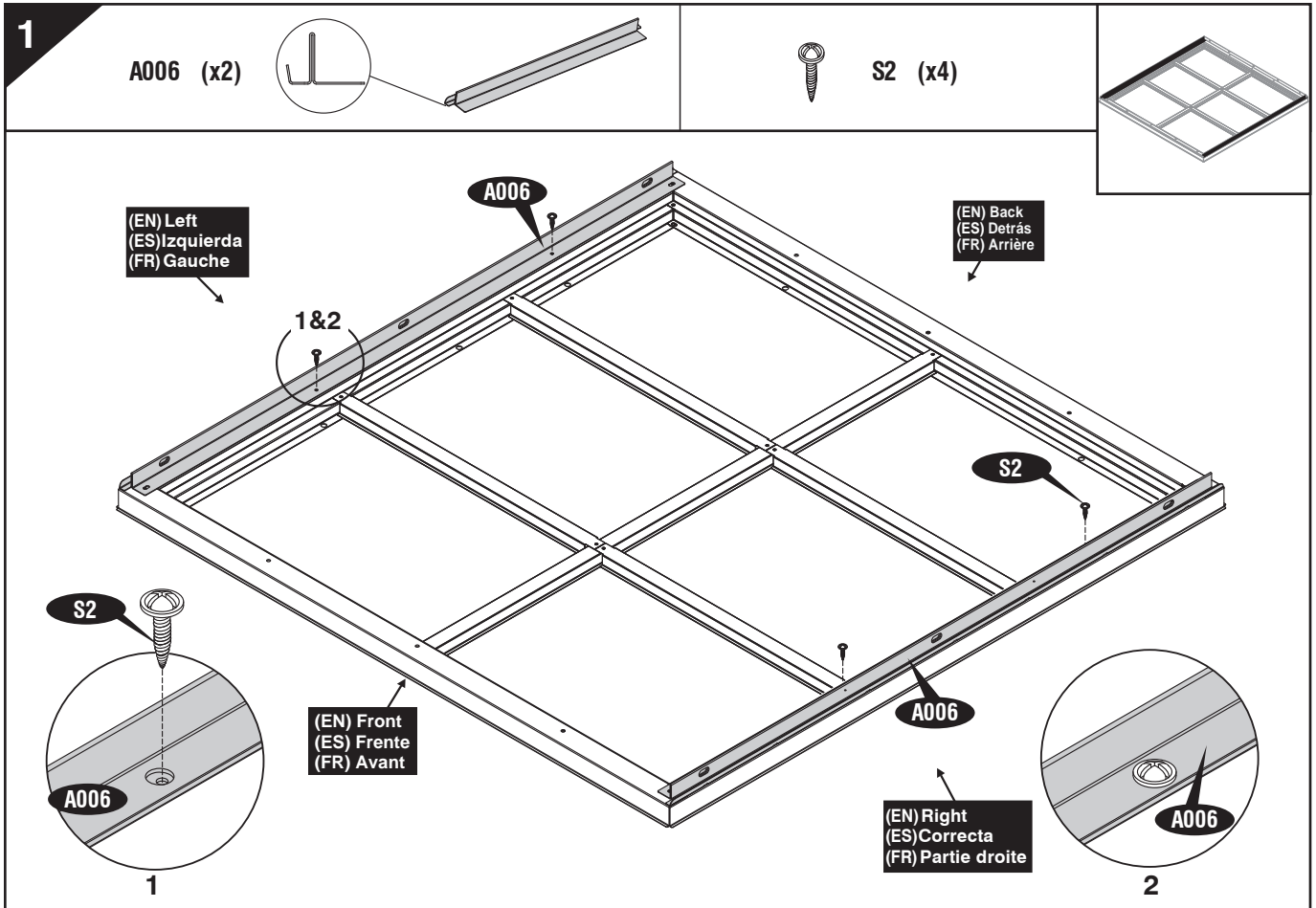

12

(EN) IMPORTANT: USE HAND GLOVES TO PREVENT INJURY.
 (FR) IMPORTANT: UTILISER LES GANTS POUR PREVENIR LES ACCIDENTS.

(ES) IMPORTANTE: GUANTES DE MANO DE USO PARA PREVENIR LA HERIDA.

2

A005 (x2)

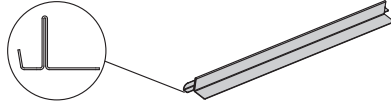

S2 (x10)

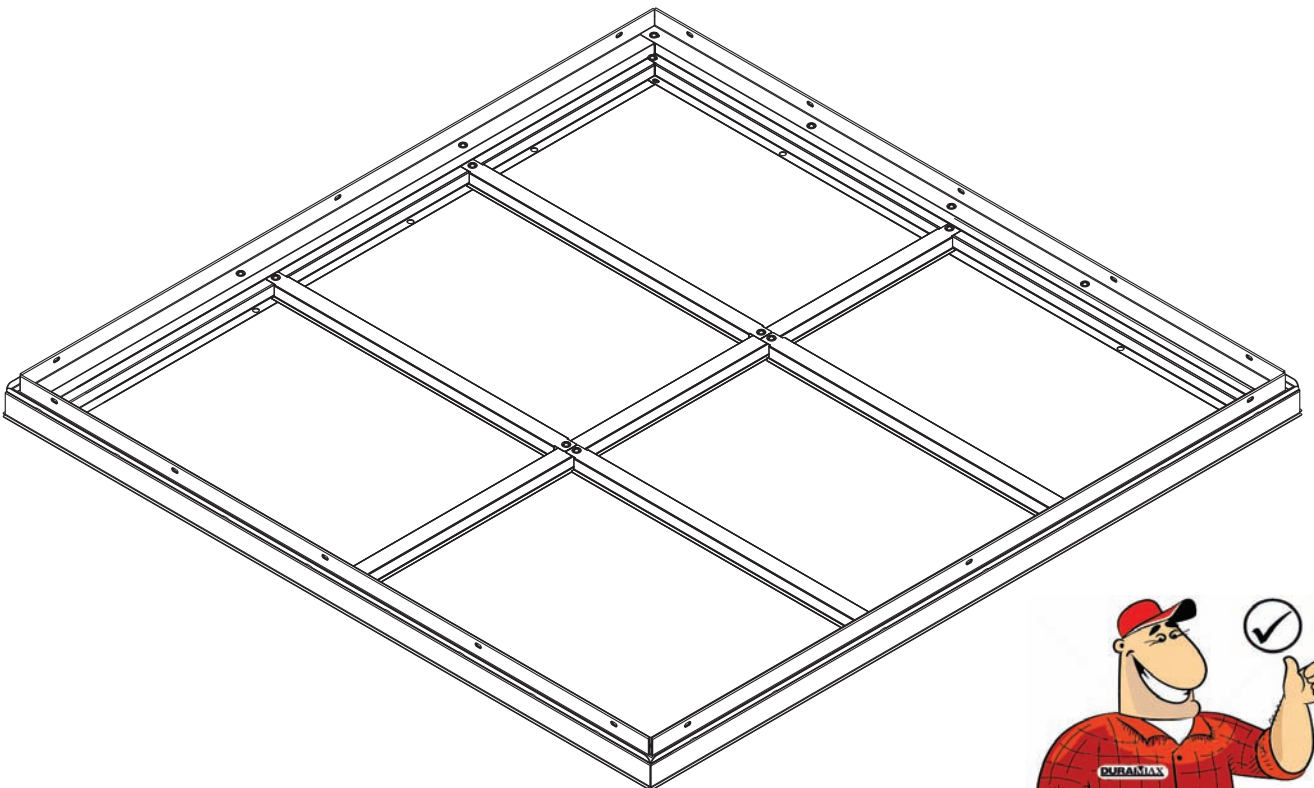
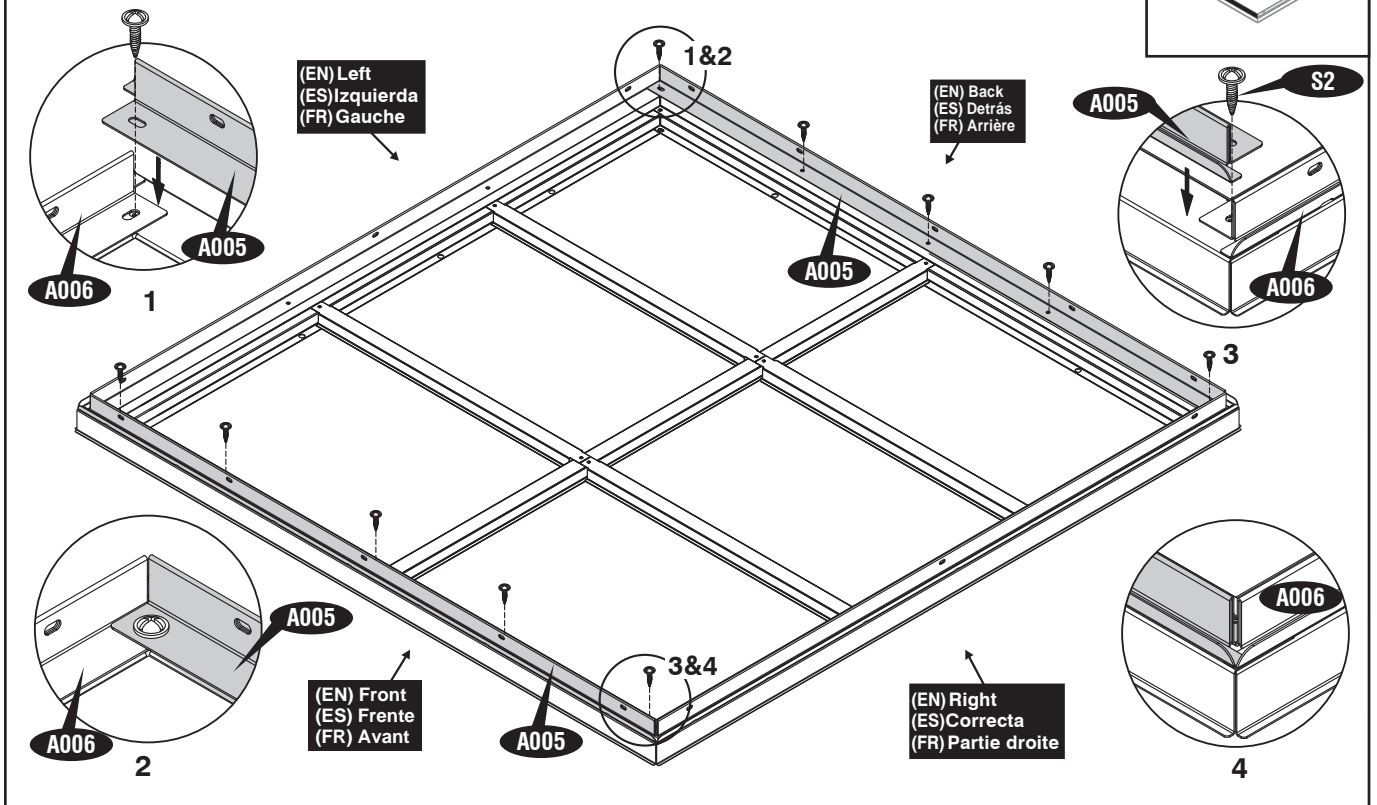

13

(EN) IMPORTANT: USE HAND GLOVES TO PREVENT INJURY.
(FR) IMPORTANT: UTILISER LES GANTS POUR PREVENIR LES ACCIDENTS.

(ES) IMPORTANTE: GUANTES DE MANO DE USO PARA PREVENIR LA HERIDA.



3

(EN) Walls & Columns
(ES) Las paredes & las Columnas
(FR) Murs et montants



(EN) : All parts are clearly marked and care should be taken to use the correct one.
(ES) : Todo pone piezas son marcados claramente y cuidan debe ser tomado para usar el corrige uno.
(FR) : Toutes les pièces sont clairement identifiées et il faut veiller à utiliser la bonne.

(EN) Parts needed
(ES) Las partes necesitaron
(FR) Pièces nécessaires

(EN)CODE (ES)CODE (FR)CODE	(EN)QTY (ES)QTY (FR)QTÉ
A008	1
A009	2
A013	1
A014	1
A015	2
A016	1
A017	1
A036	2
A037	4
A038	1
A039	1
A054	54



(EN) Two people needed.
(ES) Dos personas que se necesitan.
(FR) Deux personnes nécessaires.



(EN) Note: Do not fully tighten the bolts & nuts until complete the assembly.
(ES) Nota: No apriete completamente los pernos & tuercas hasta completan el montaje.
(FR) Note: Ne pas serrer les boulons & écrous jusqu'à compléter l'assemblage.

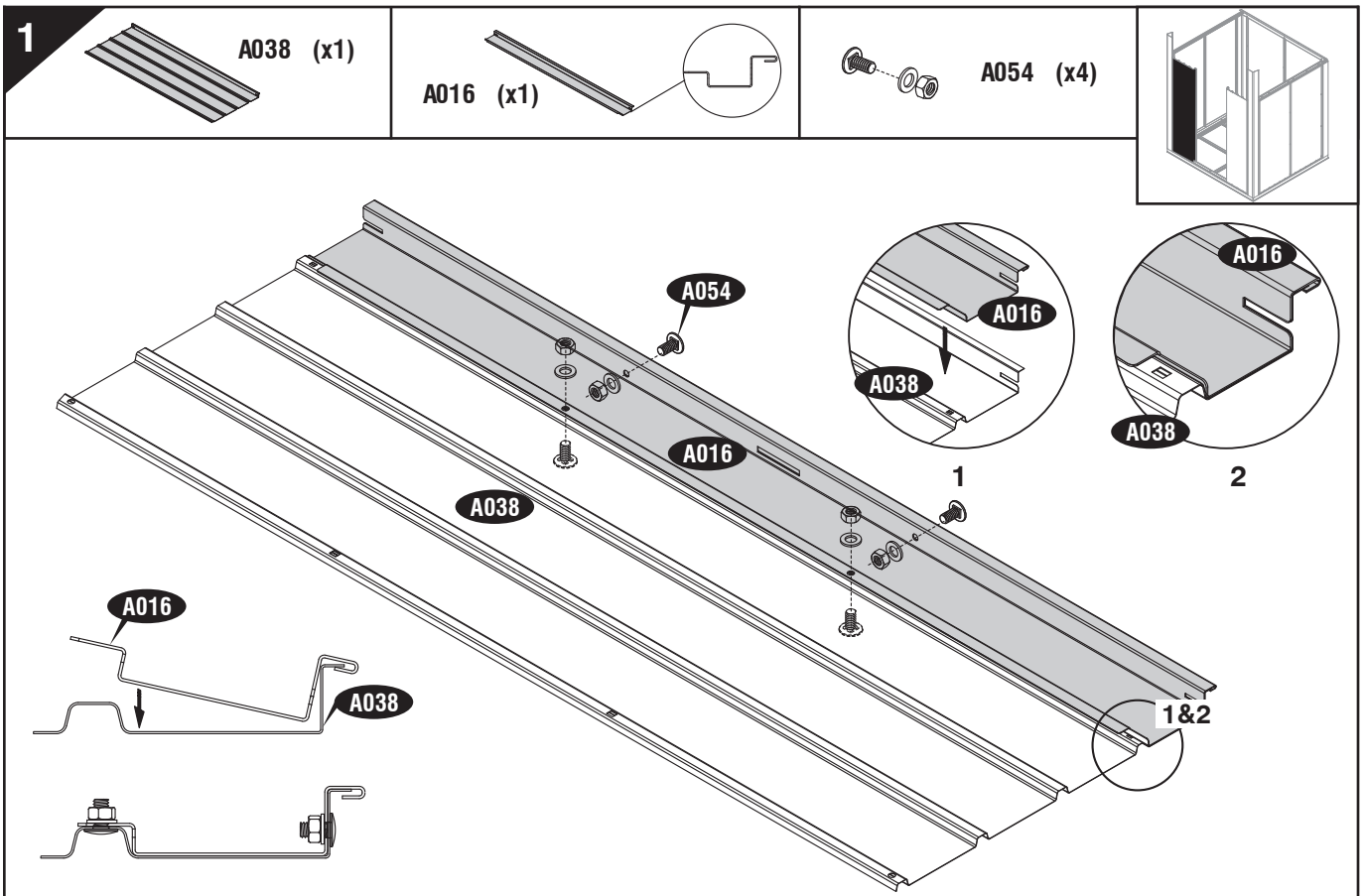

2

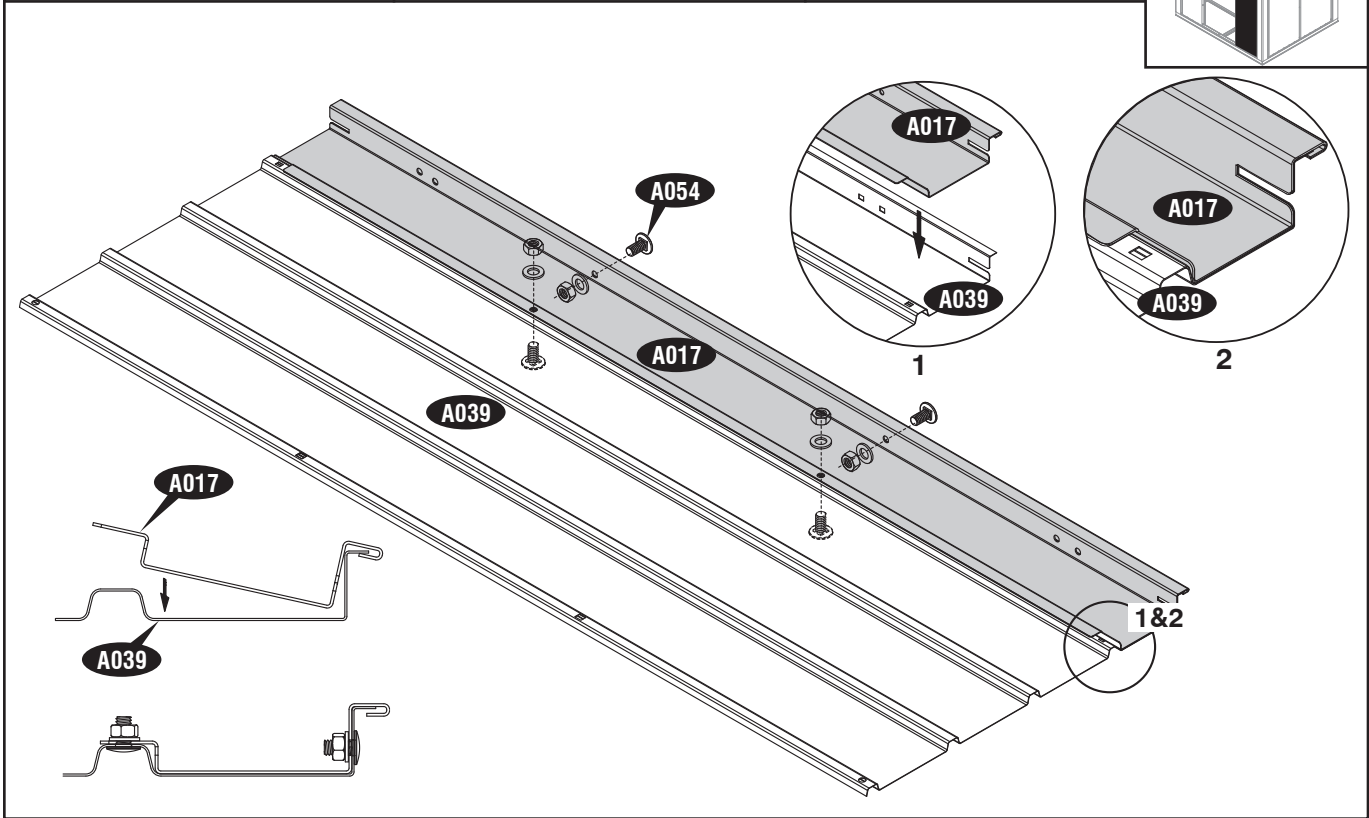
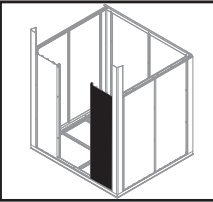
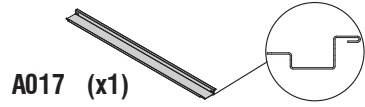
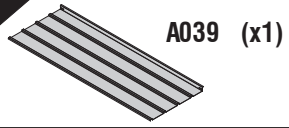

3

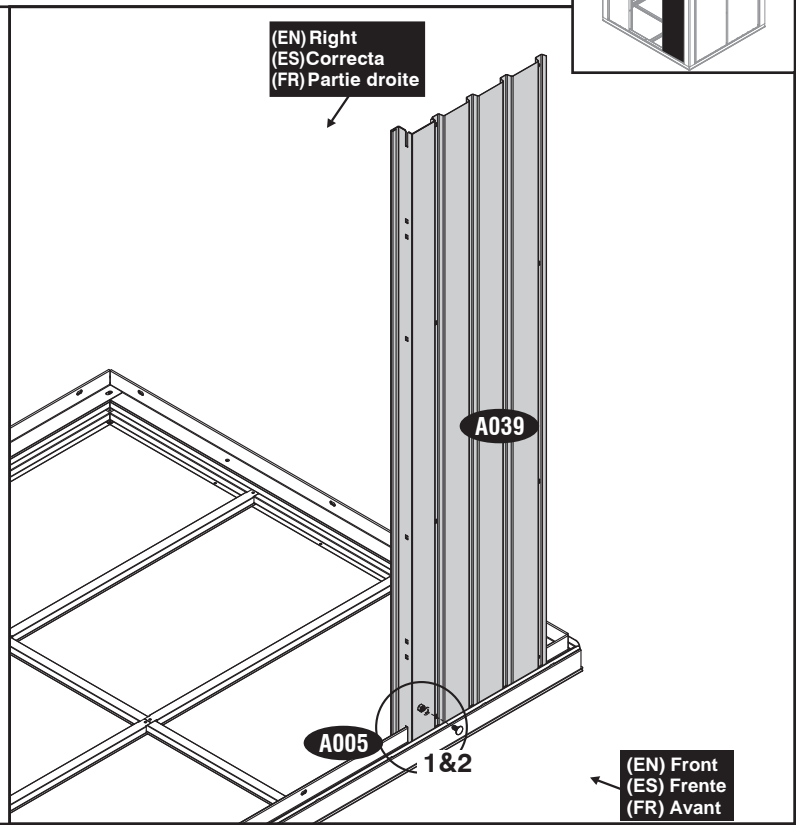
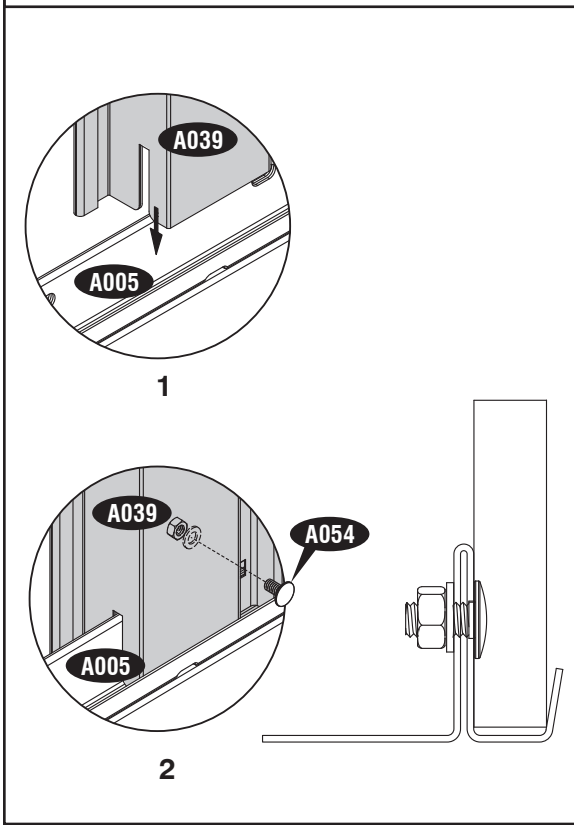
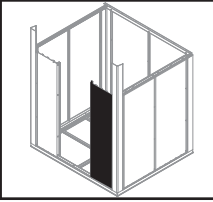

15

4

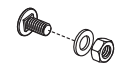
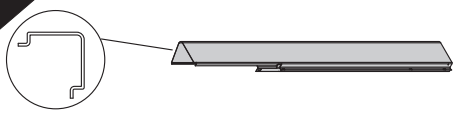

A054 (x3)

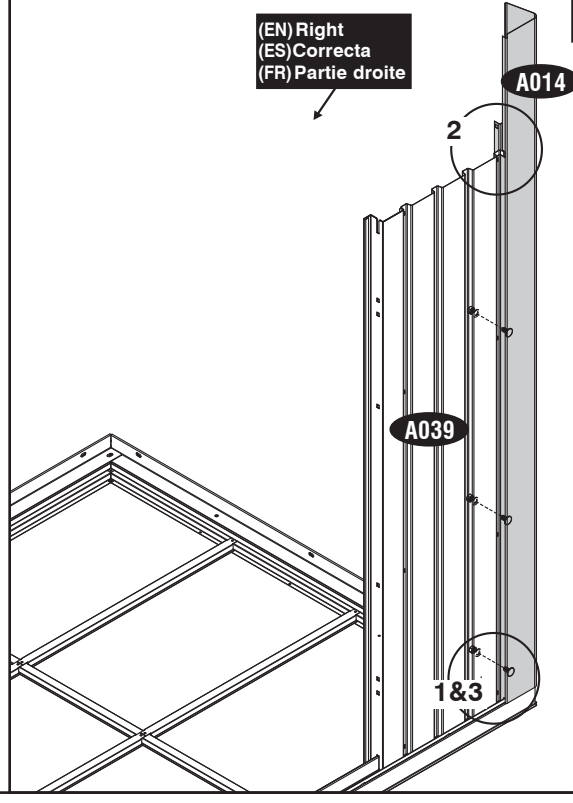
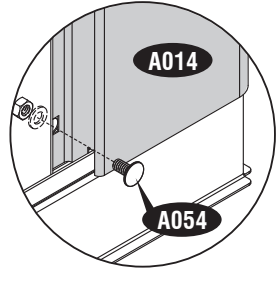
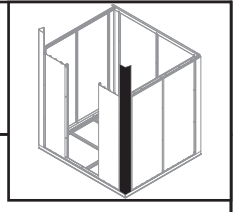

5

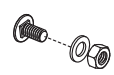
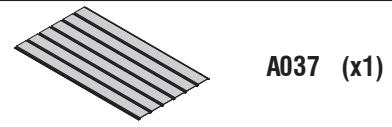

A054 (x3)

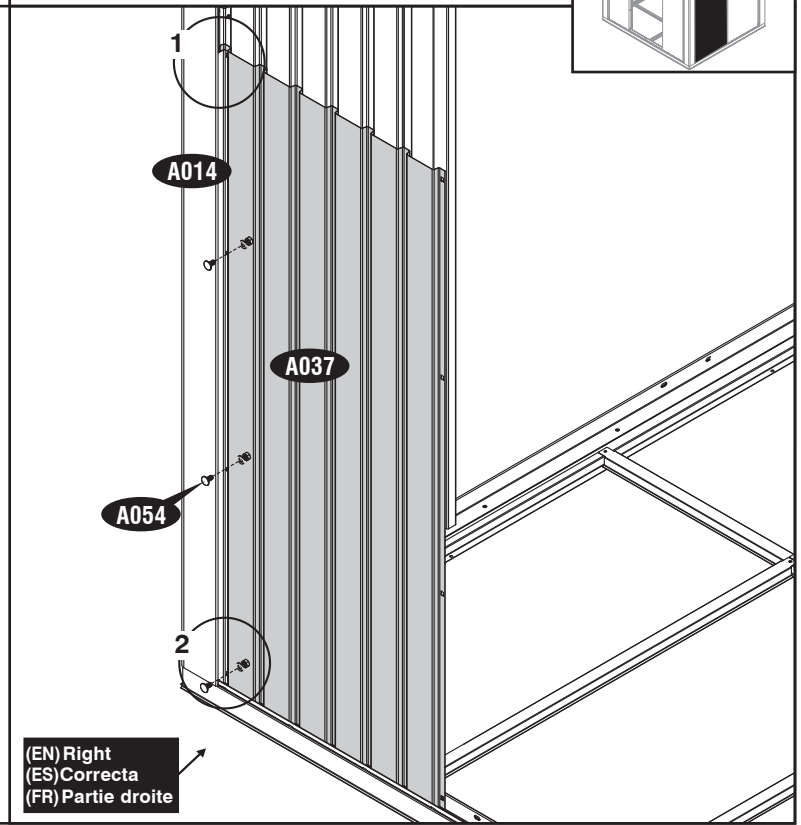
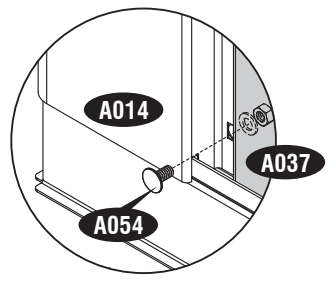
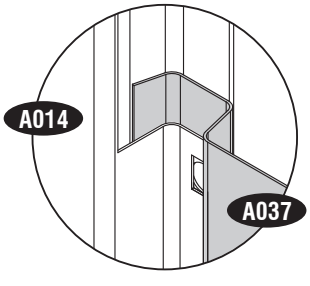
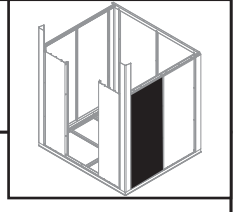

16

(EN) IMPORTANT: USE HAND GLOVES TO PREVENT INJURY.
(FR) IMPORTANT: UTILISER LES GANTS POUR PREVENIR LES ACCIDENTS.

(ES) IMPORTANTE: GUANTES DE MANO DE USO PARA PREVENIR LA HERIDA.

6

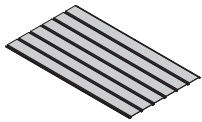

A037 (x1)

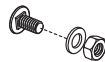

A054 (x3)

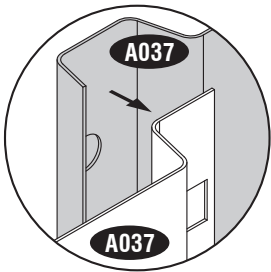
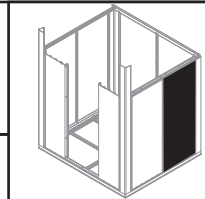

1

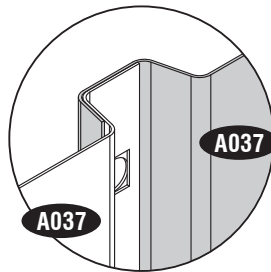

2

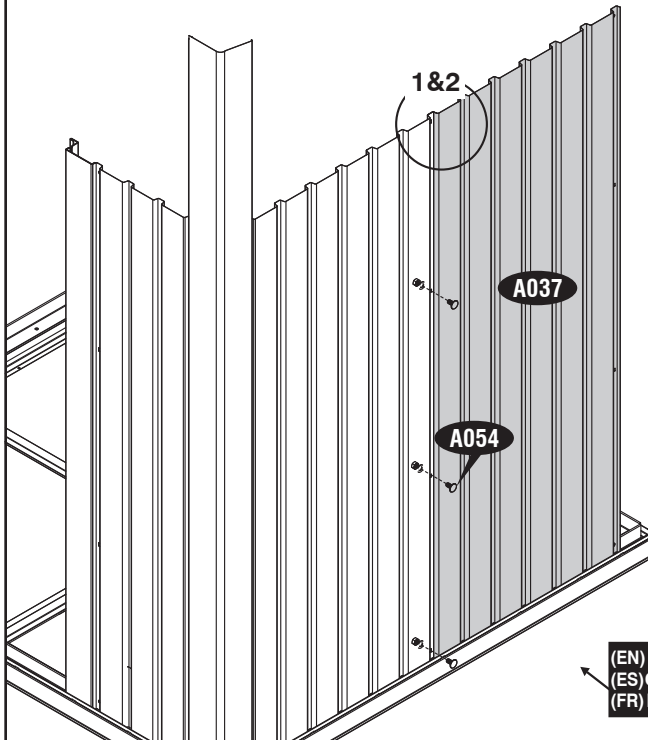

(EN) Right
(ES) Correcta
(FR) Partie droite

7

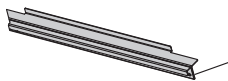

A009 (x1)

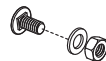

A054 (x2)

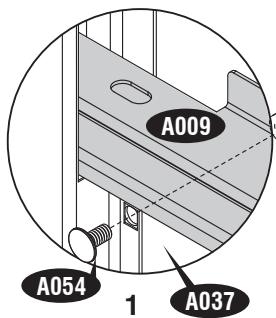
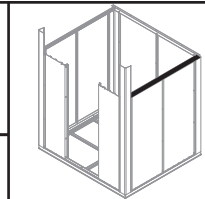

1

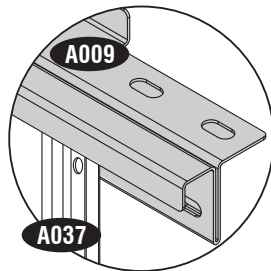

2

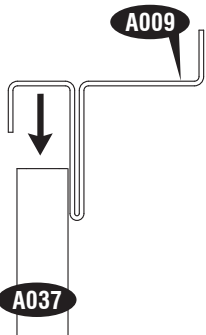

A037

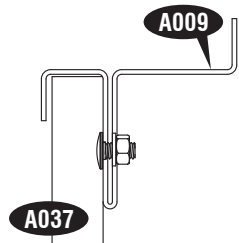

A037

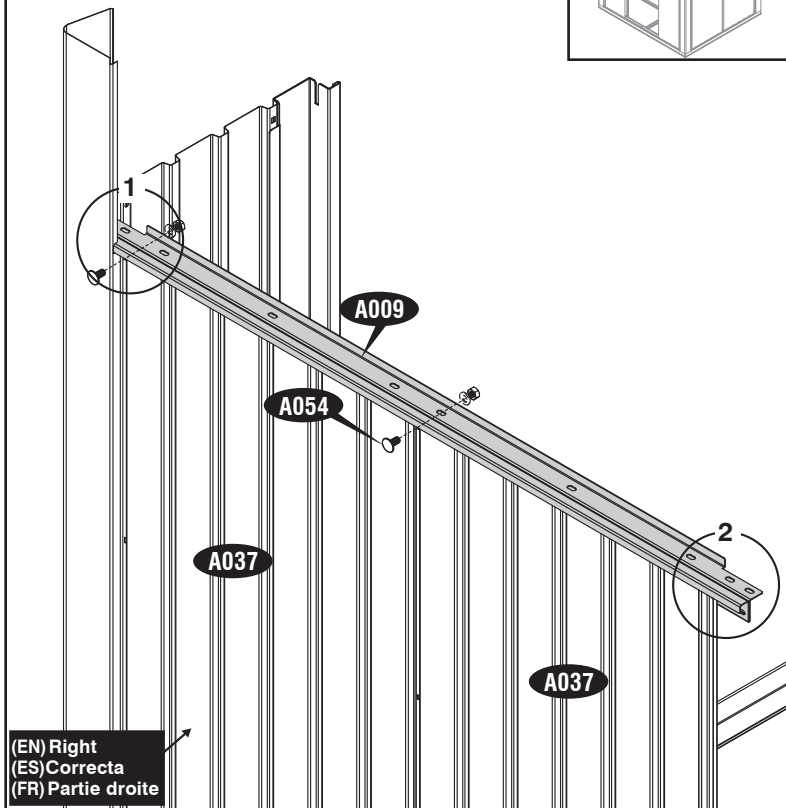

(EN) Right
(ES) Correcta
(FR) Partie droite

17

8



A015 (x1)

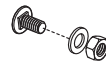

A054 (x4)

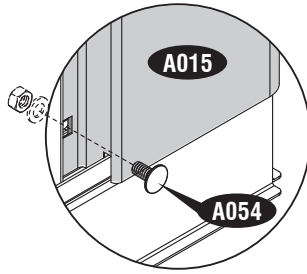
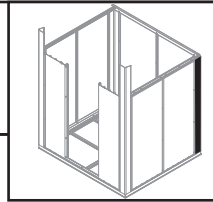

1

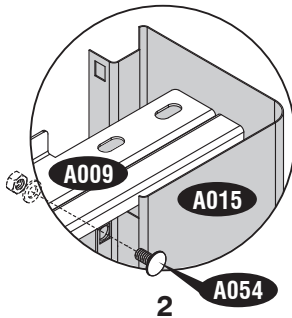

2

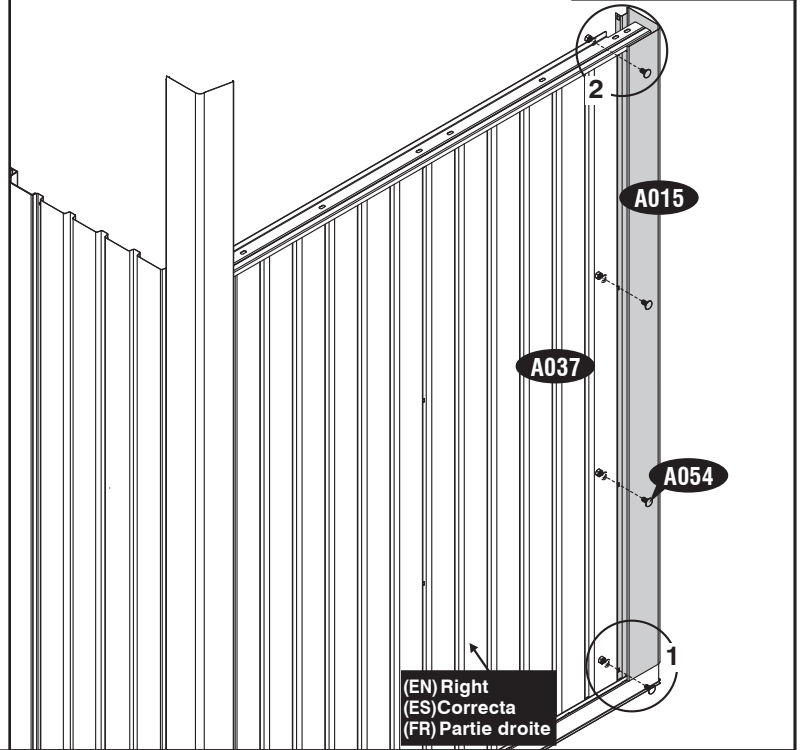

(EN) Right
(ES) Correcta
(FR) Partie droite

9

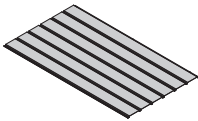

A036 (x1)

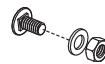

A054 (x3)

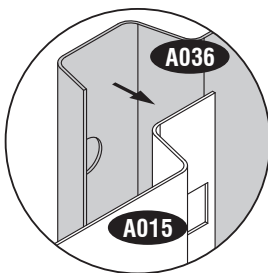
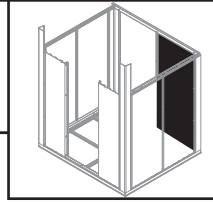

1

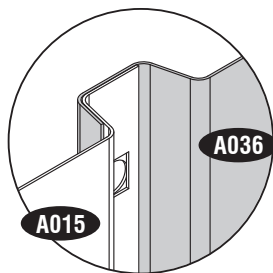

2

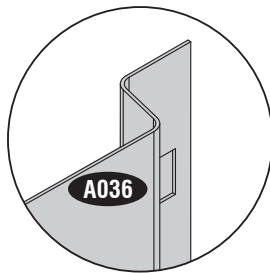

3

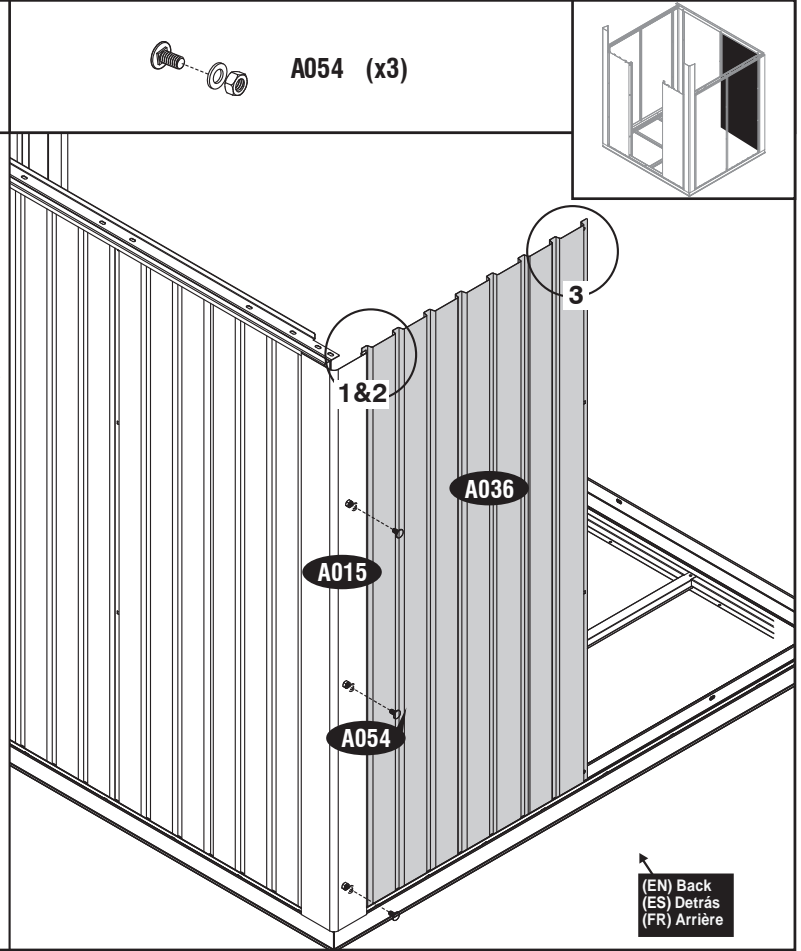

(EN) Back
(ES) Detrás
(FR) Arrière

18

(EN) IMPORTANT: USE HAND GLOVES TO PREVENT INJURY.
(FR) IMPORTANT: UTILISER LES GANTS POUR PREVENIR LES ACCIDENTS.

(ES) IMPORTANTE: GUANTES DE MANO DE USO PARA PREVENIR LA HERIDA.

10

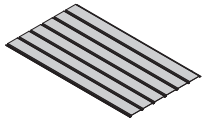

A036 (x1)



A054 (x3)

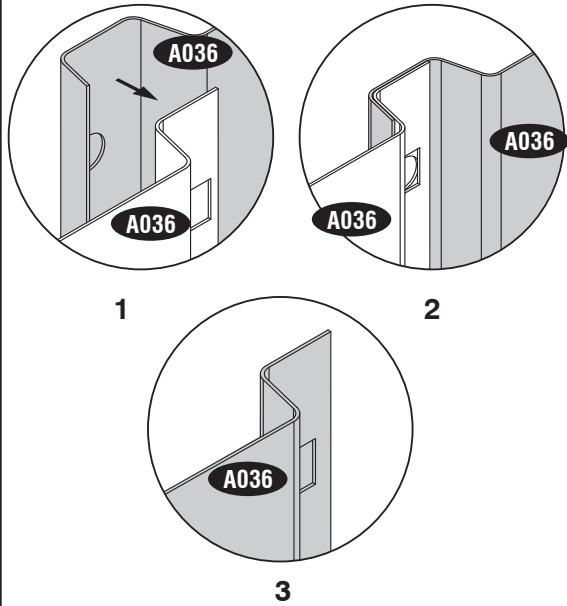
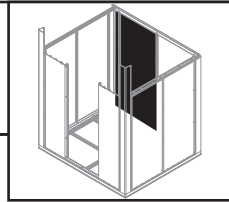

1

2

3

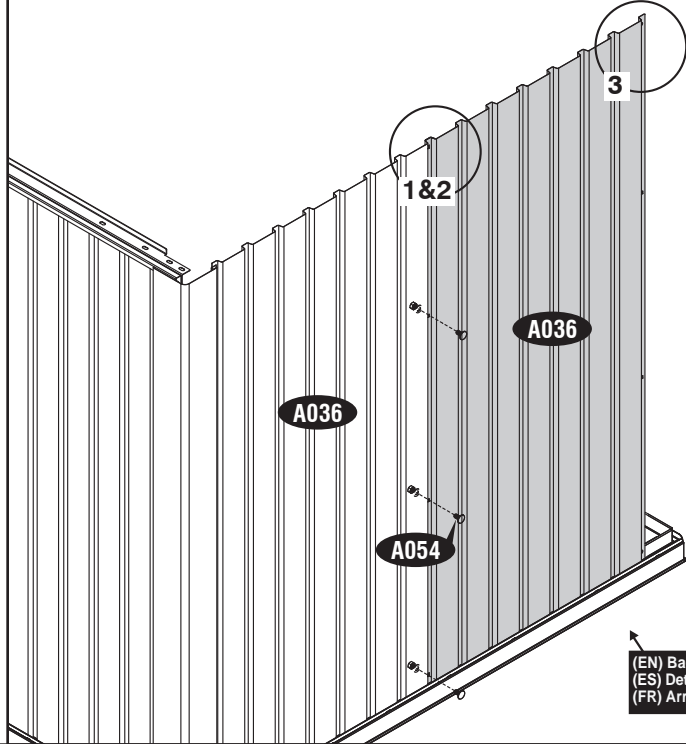

(EN) Back
(ES) Detrás
(FR) Arrière

11



A008 (x1)

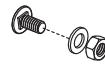

A054 (x3)

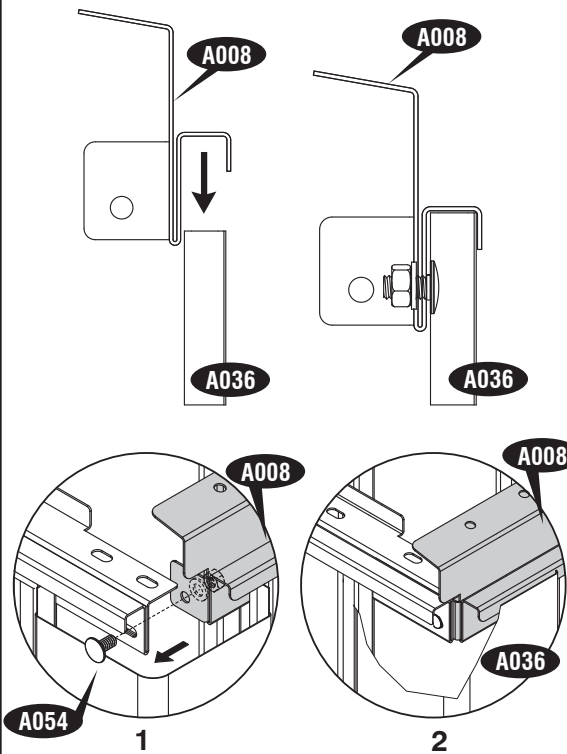
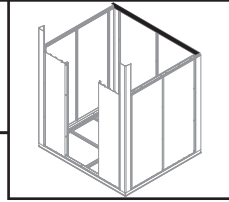

1

2

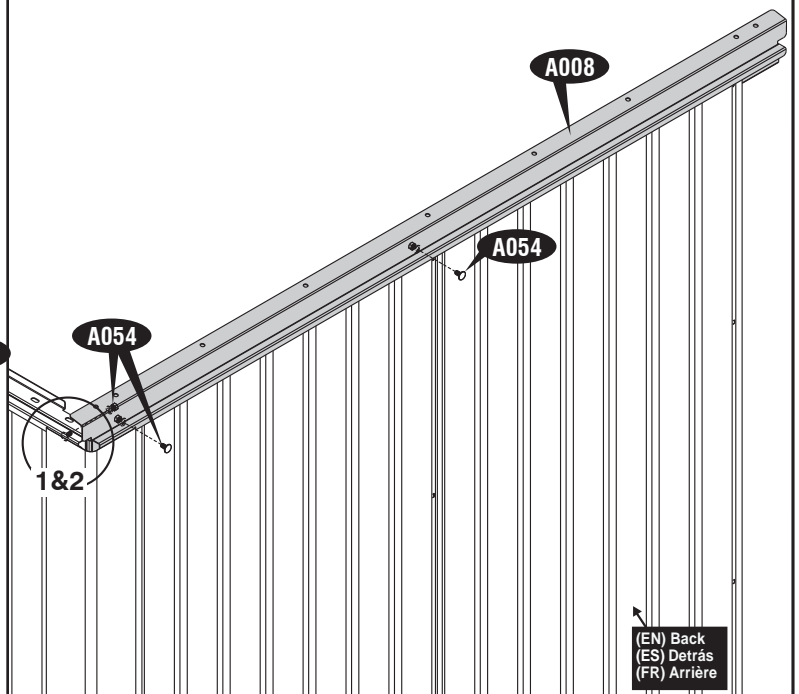

(EN) Back
(ES) Detrás
(FR) Arrière

19

(EN) IMPORTANT: USE HAND GLOVES TO PREVENT INJURY.
(FR) IMPORTANT: UTILISER LES GANTS POUR PREVENIR LES ACCIDENTS.

(ES) IMPORTANTE: GUANTES DE MANO DE USO PARA PREVENIR LA HERIDA.

12



A015 (x1)

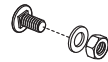

A054 (x4)

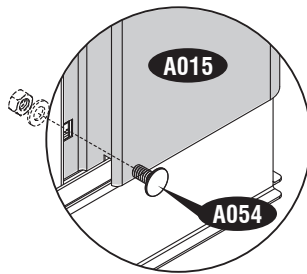
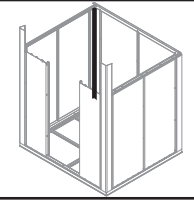

1

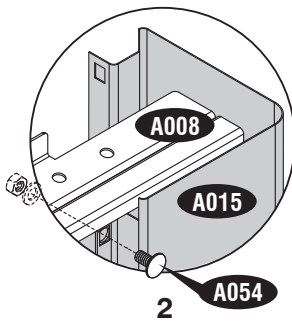

2

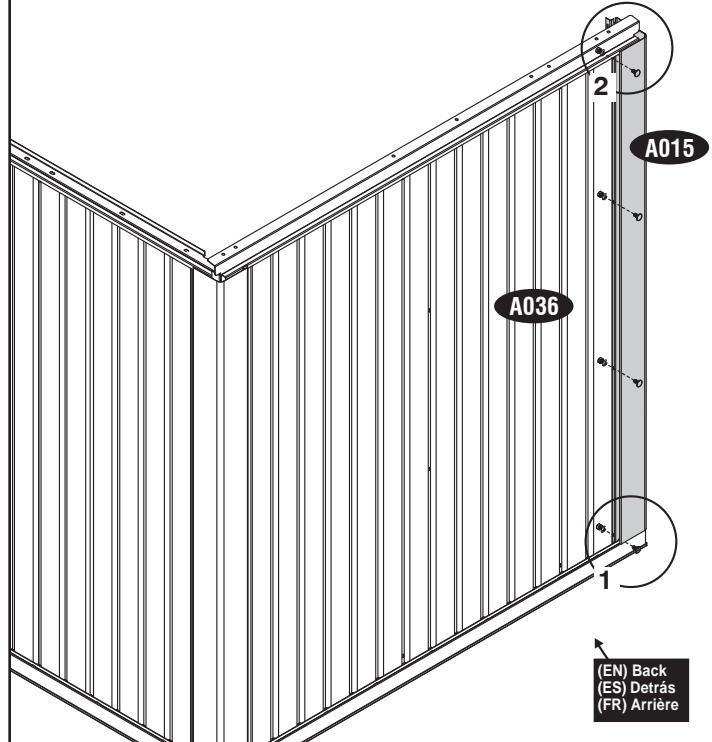

(EN) Back
(ES) Detrás
(FR) Arrière

13

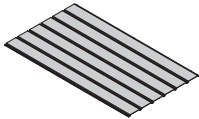

A037 (x1)



A054 (x3)

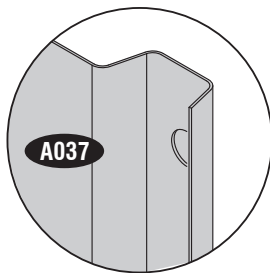
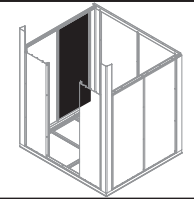

1

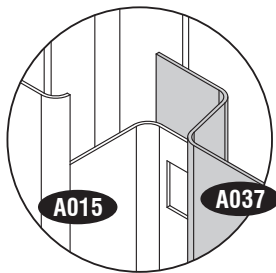

2

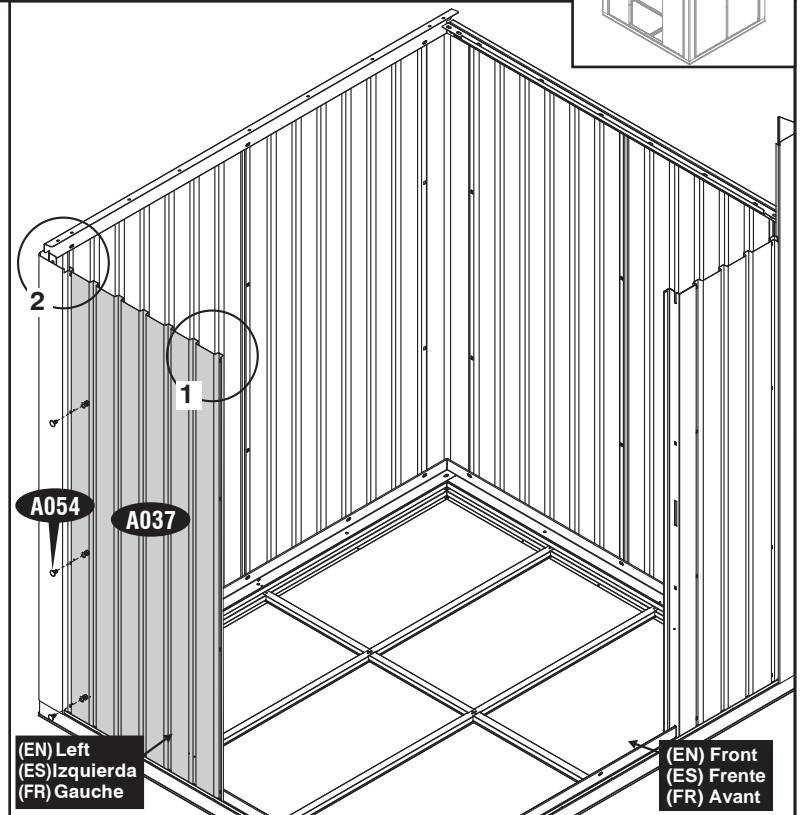

(EN) Left
(ES) Izquierda
(FR) Gauche

(EN) Front
(ES) Frente
(FR) Avant

20

14

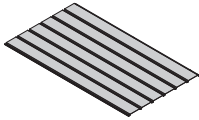

A037 (x1)

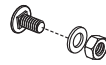

A054 (x3)

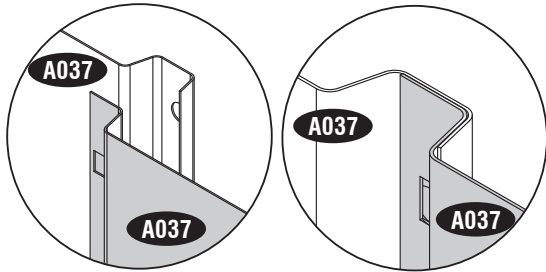
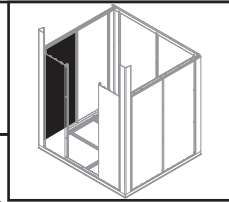

1

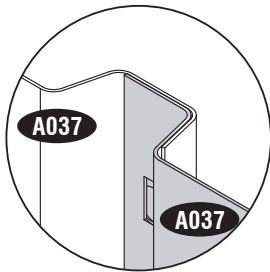

2

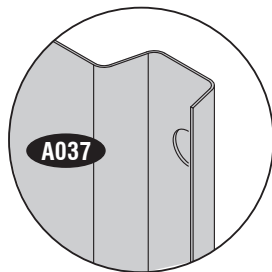

3

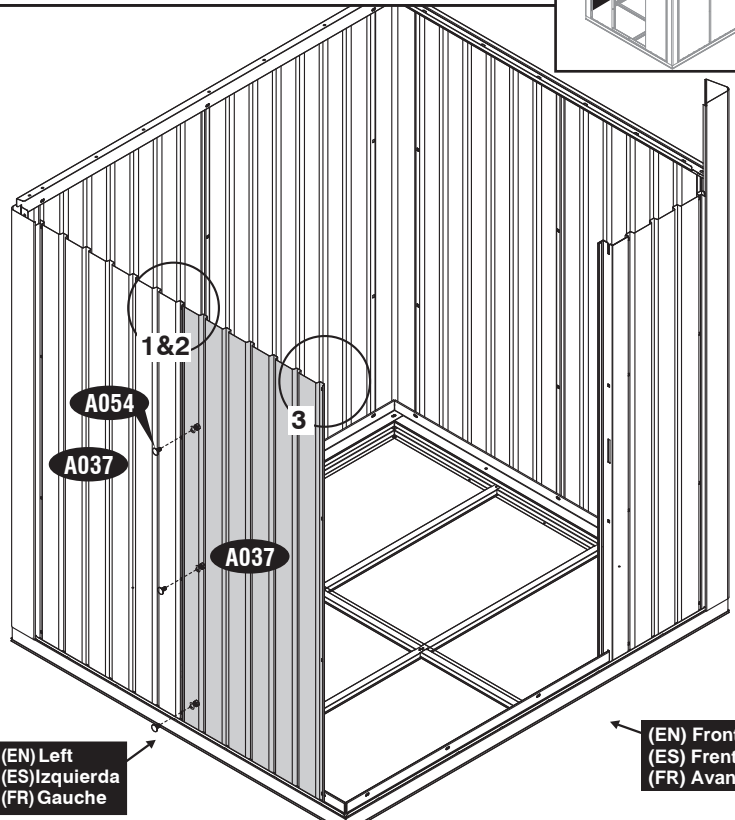

15

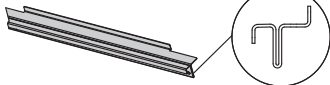

A009 (x1)

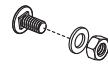

A054 (x3)

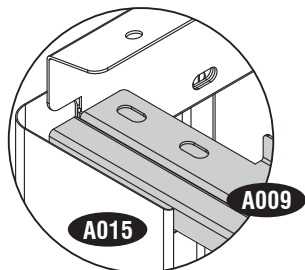
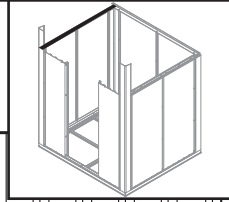

1

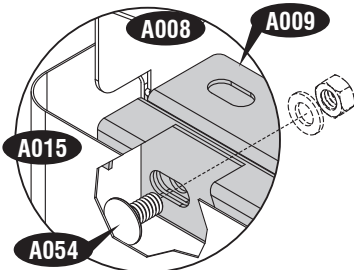

2

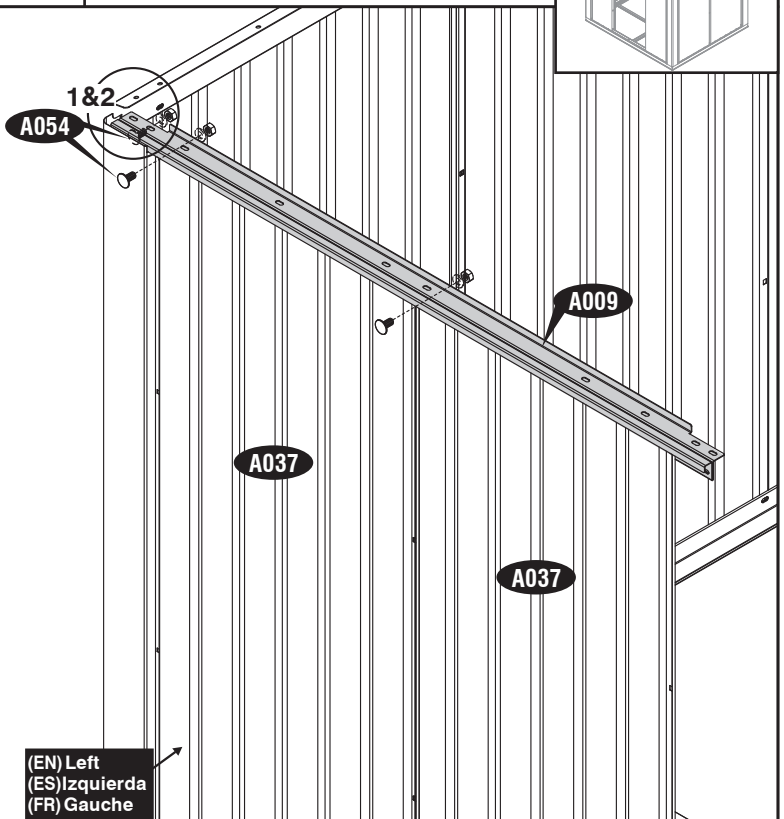

21

16



A013 (x1)



A054 (x4)

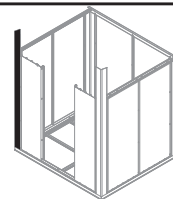

1

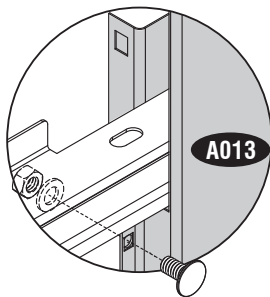

2

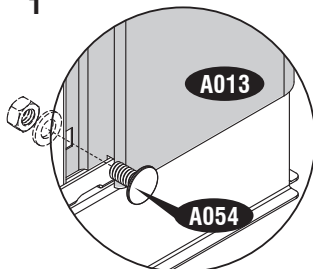

3

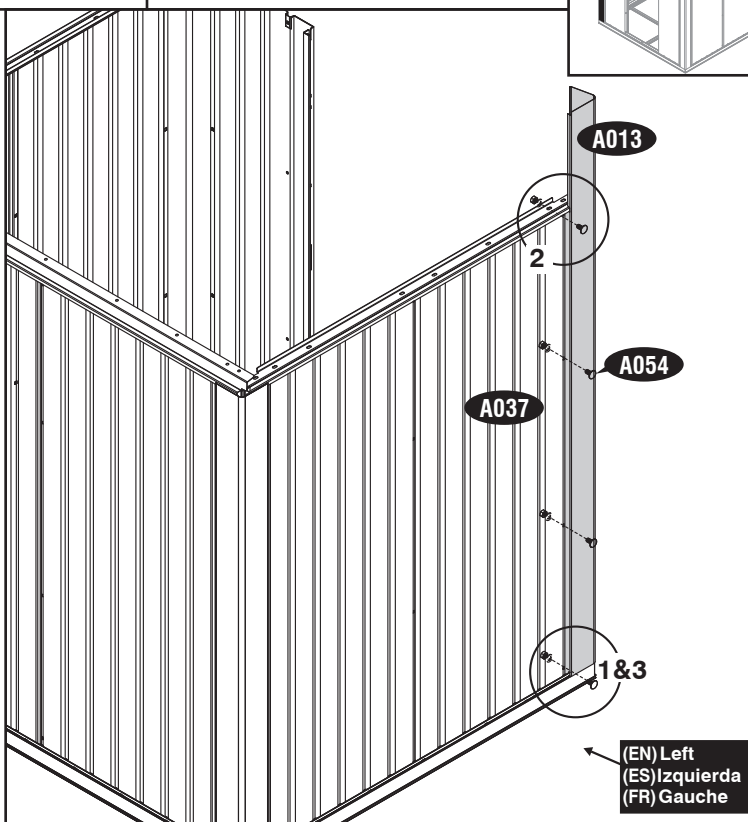

(EN) Left
(ES) Izquierda
(FR) Gauche

17

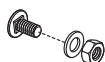

A054 (x4)

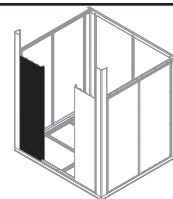

1

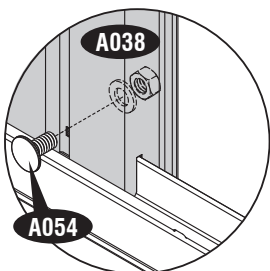

2

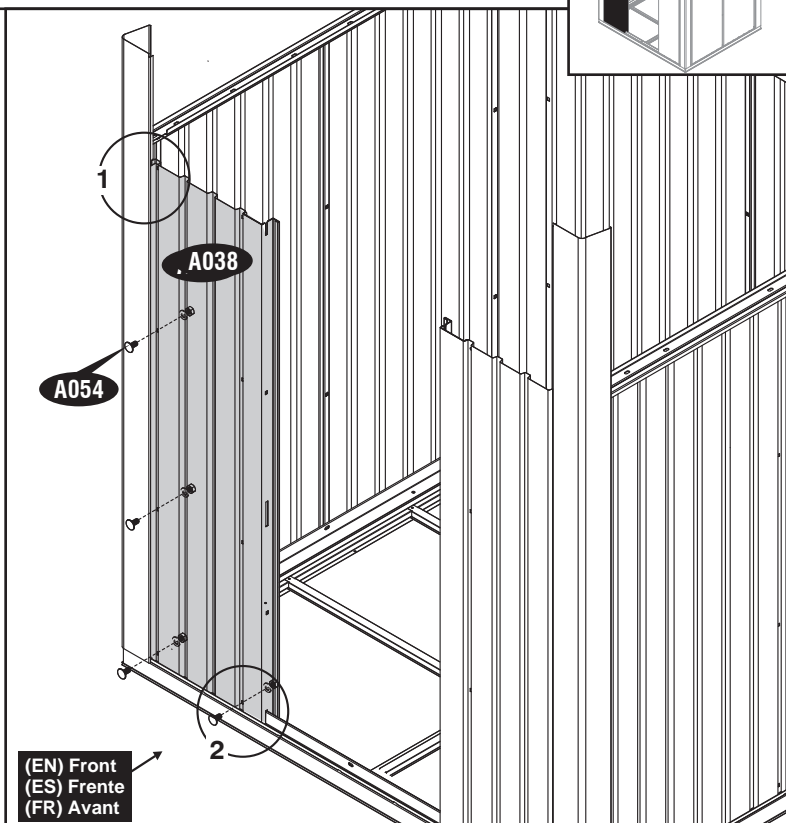

(EN) Front
(ES) Frente
(FR) Avant



22

(EN) IMPORTANT: USE HAND GLOVES TO PREVENT INJURY.
(FR) IMPORTANT: UTILISER LES GANTS POUR PREVENIR LES ACCIDENTS.

(ES) IMPORTANTE: GUANTES DE MANO DE USO PARA PREVENIR LA HERIDA.



4

(EN) Roof
(ES) El atecho
(FR) Toit



(EN) Parts needed
(ES) Las partes necesitaron
(FR) Pièces nécessaires

(EN)CODE (ES)CODE (FR)CODE	(EN)QTY (ES)QTY (FR)QTÉ	(EN)CODE (ES)CODE (FR)CODE	(EN)QTY (ES)QTY (FR)QTÉ
A007	1	A026	2
A010	1	A027	2
A011	1	A029	1
A012	1	A033	1
A019	1	A034	1
A020	1	A041	2
A021	1	A047	1
A022	1	A054	61
A023	1	A055	14
A024	1	S2	2
A025	1		



(EN) Note: Do not fully tighten the bolts & nuts until complete the assembly.
(ES) Nota: No apriete completamente los pernos & tuercas hasta completan el montaje.
(FR) Note: Ne pas serrer les boulons & écrous jusqu'à compléter l'assemblage.

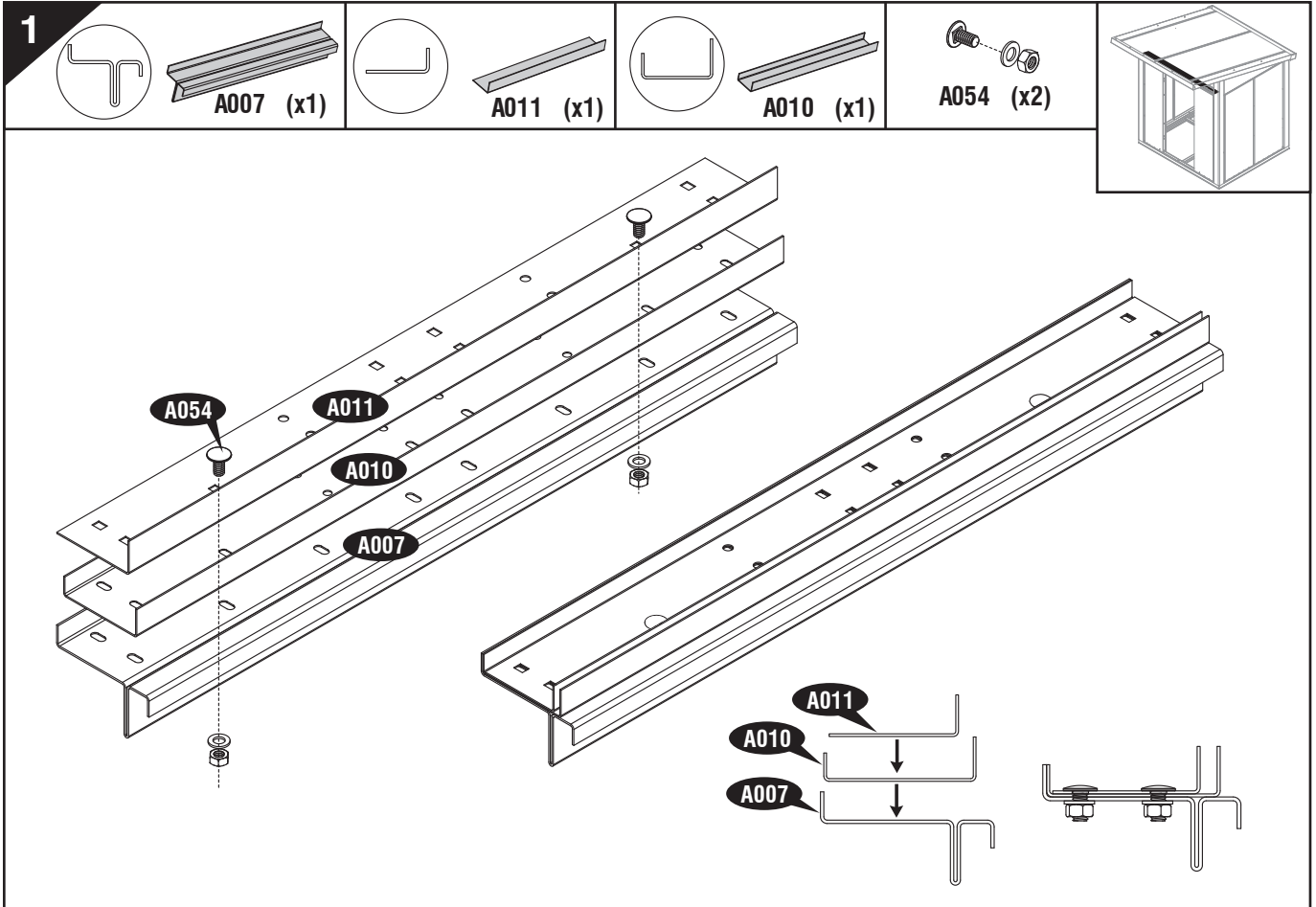

2

A055 (x4)

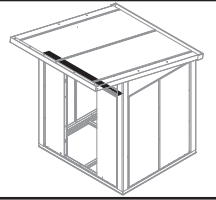

(EN) Front
(ES) Frente
(FR) Avant

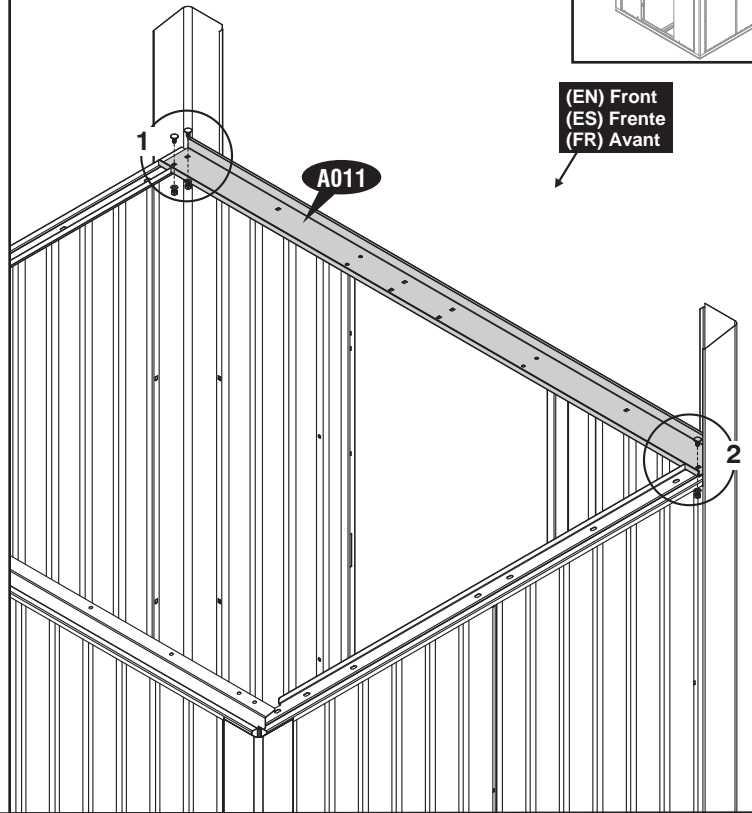
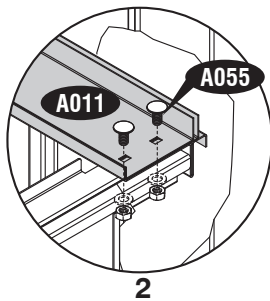
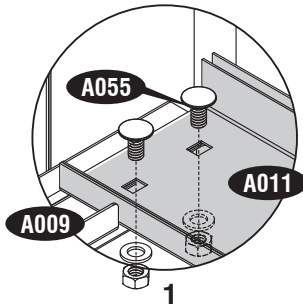

3

A047 (x1)

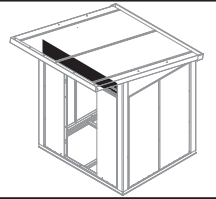

(EN) Front
(ES) Frente
(FR) Avant



(EN) Note: Remove the polyethylene film before start assembling.
(ES) Nota: Quite la Película de Polietileno antes de armar.
(FR) Note: Retirer le film de polyéthylène avant de commencer l'assemblage.

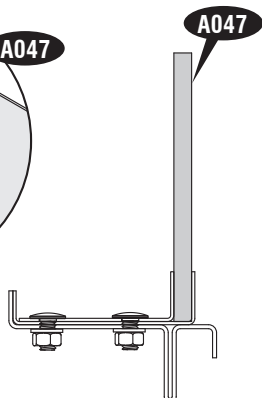
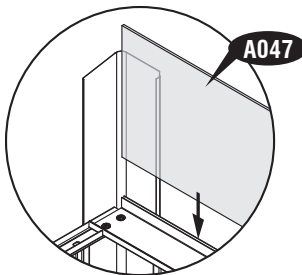
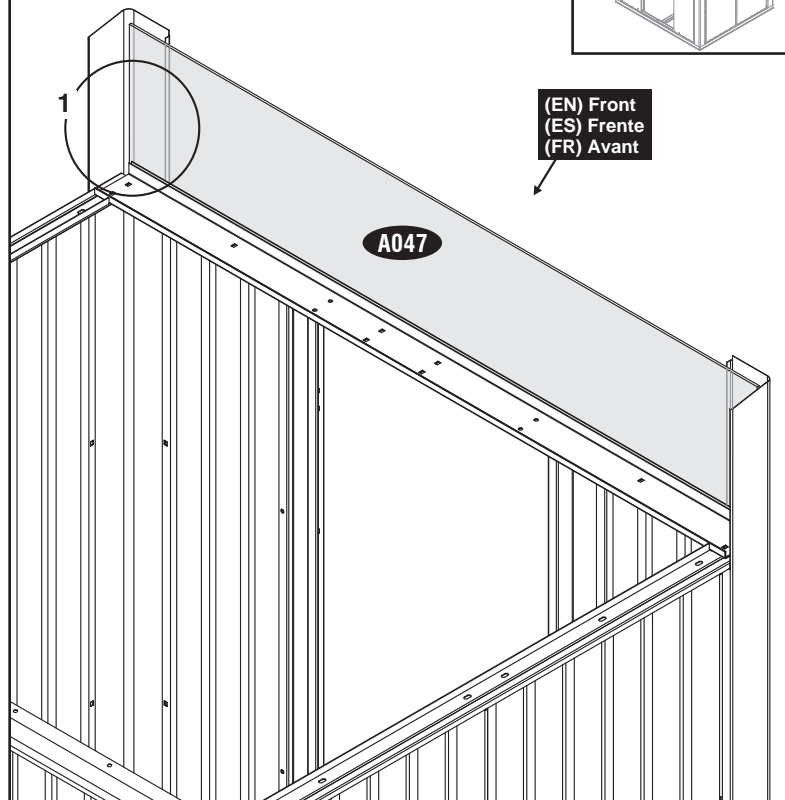

24

4

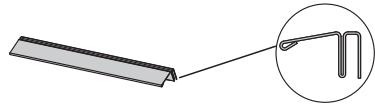

A012 (x1)

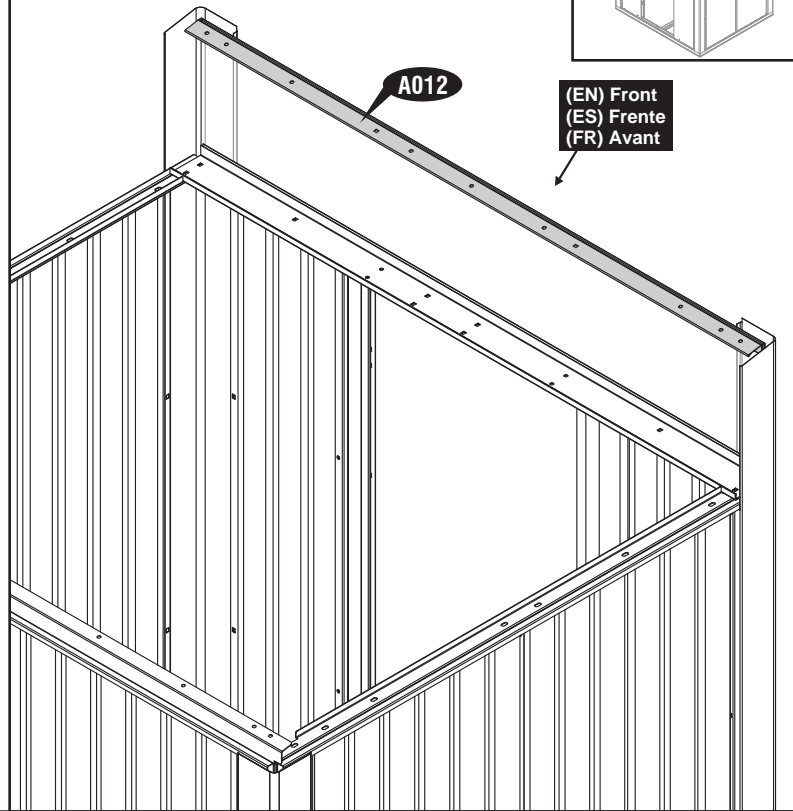
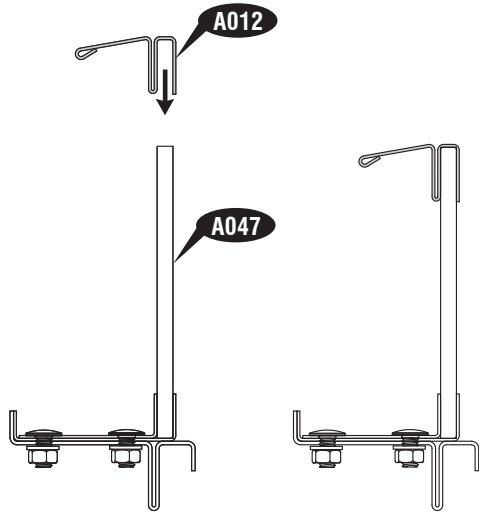
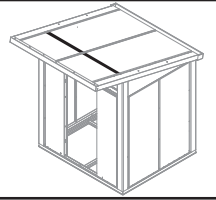

5

A026 (x2)



A055 (x6)

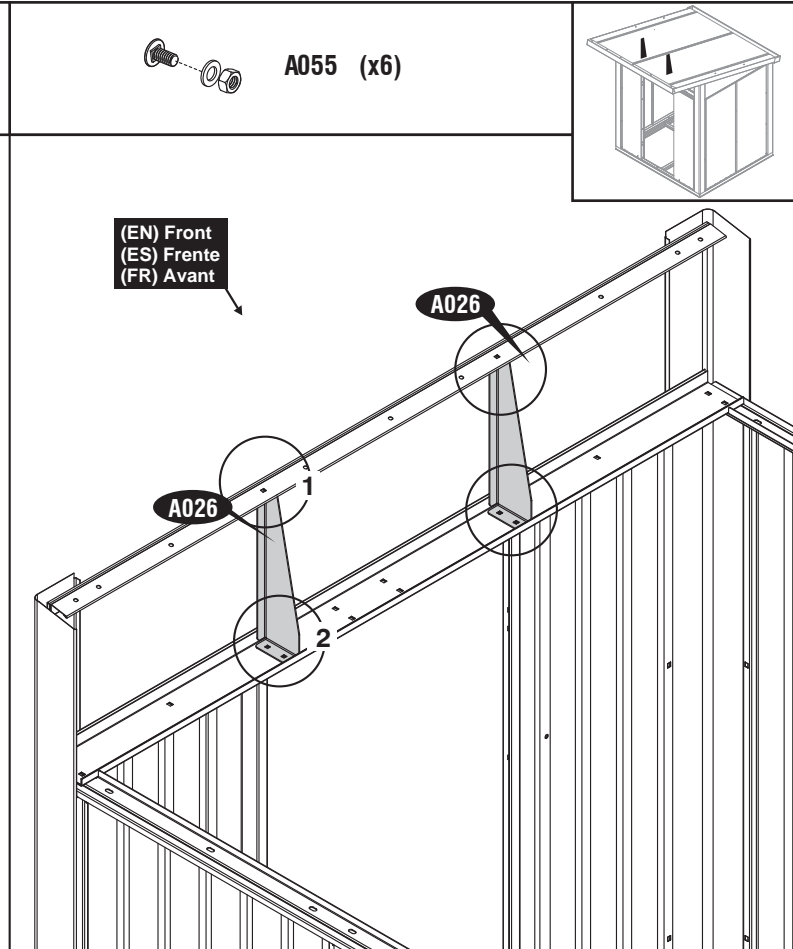
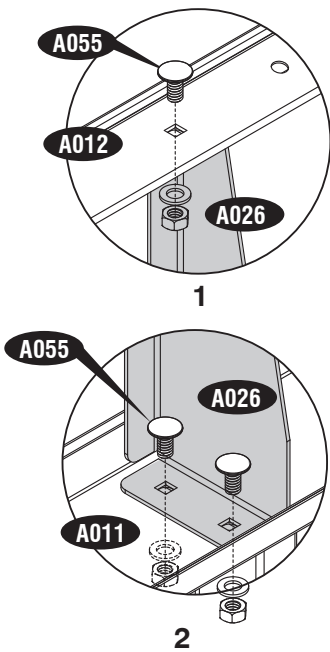
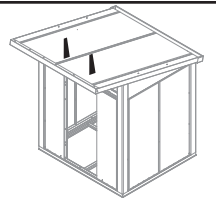

25

6

A033 (x1)

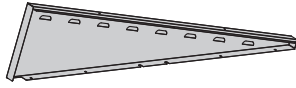

A054 (x5)

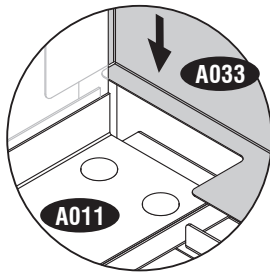
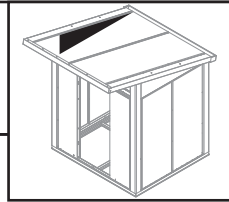

1

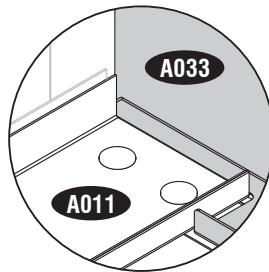

2

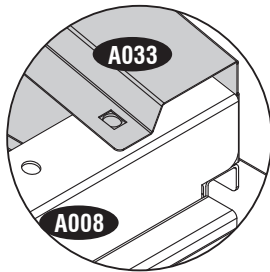

3

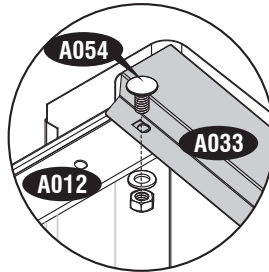

4

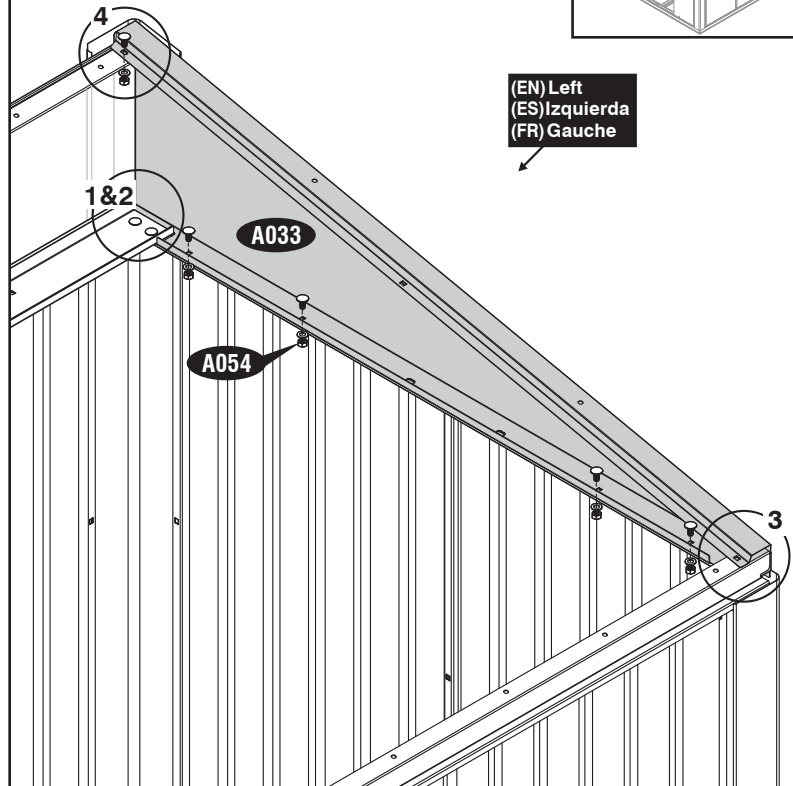

(EN) Left
(ES) Izquierda
(FR) Gauche

7

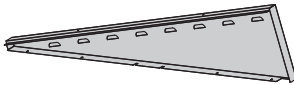

A034 (x1)

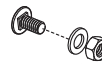

A054 (x5)

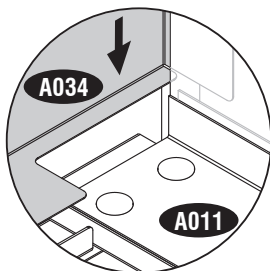
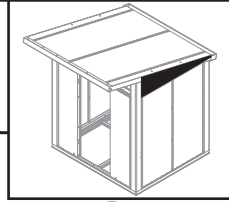

1

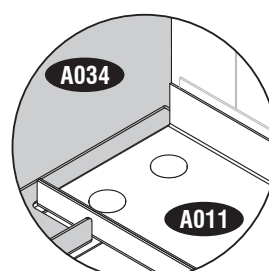

2

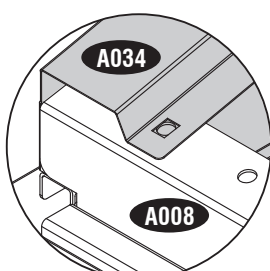

3

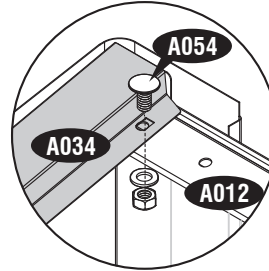

4

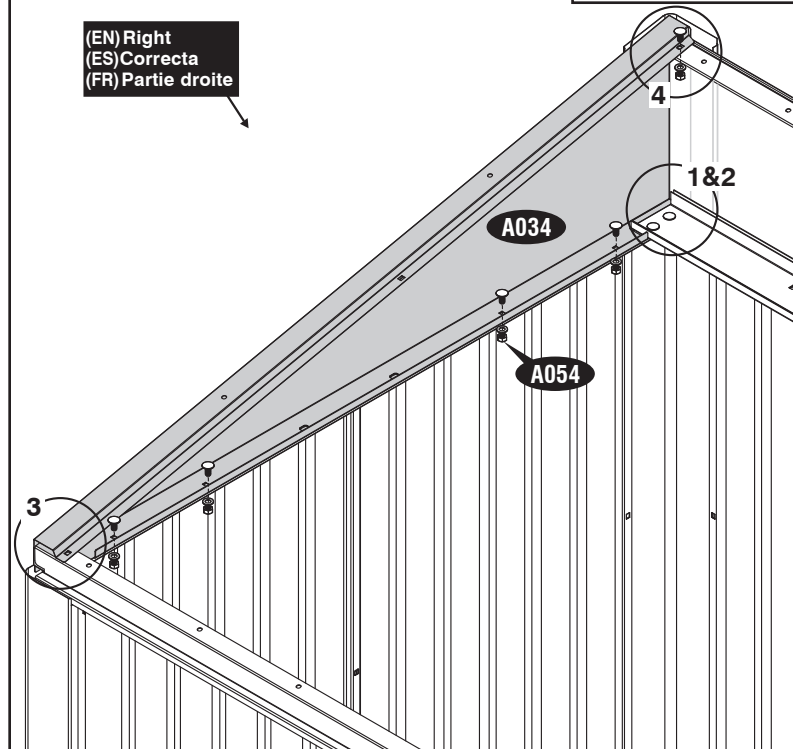

(EN) Right
(ES) Correcta
(FR) Partie droite

8

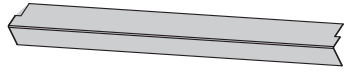

A027 (x1)

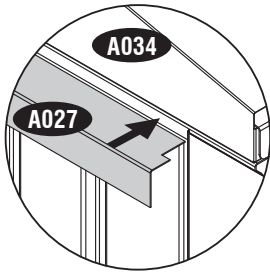
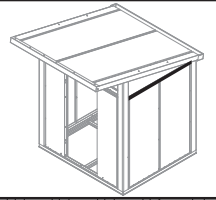

1

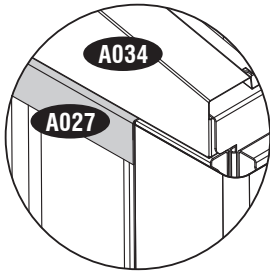

2

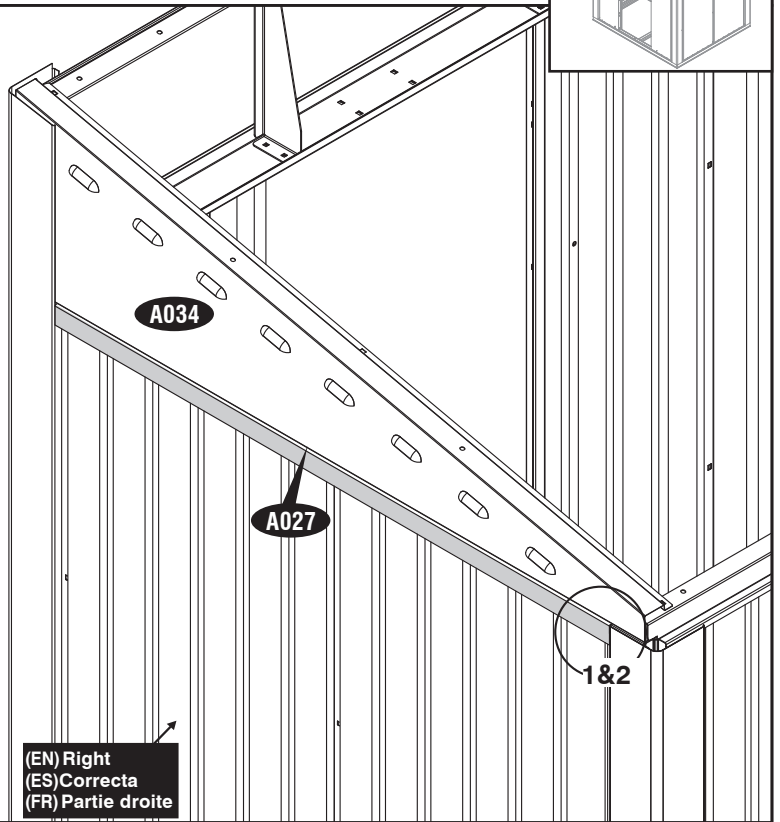

(EN) Right
(ES) Correcta
(FR) Partie droite

9

A027 (x1)

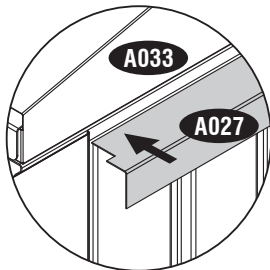
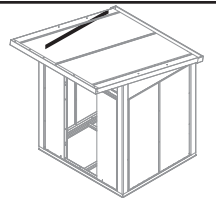
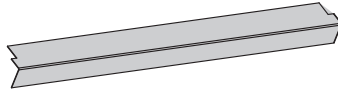

1

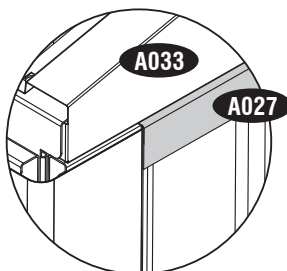

2

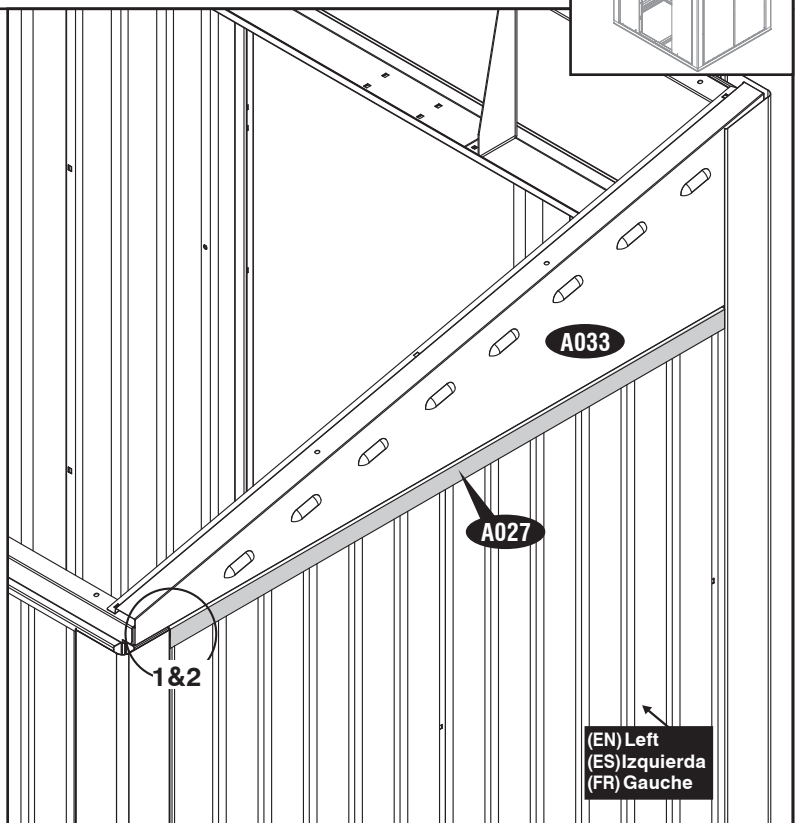

(EN) Left
(ES) Izquierda
(FR) Gauche

27

10

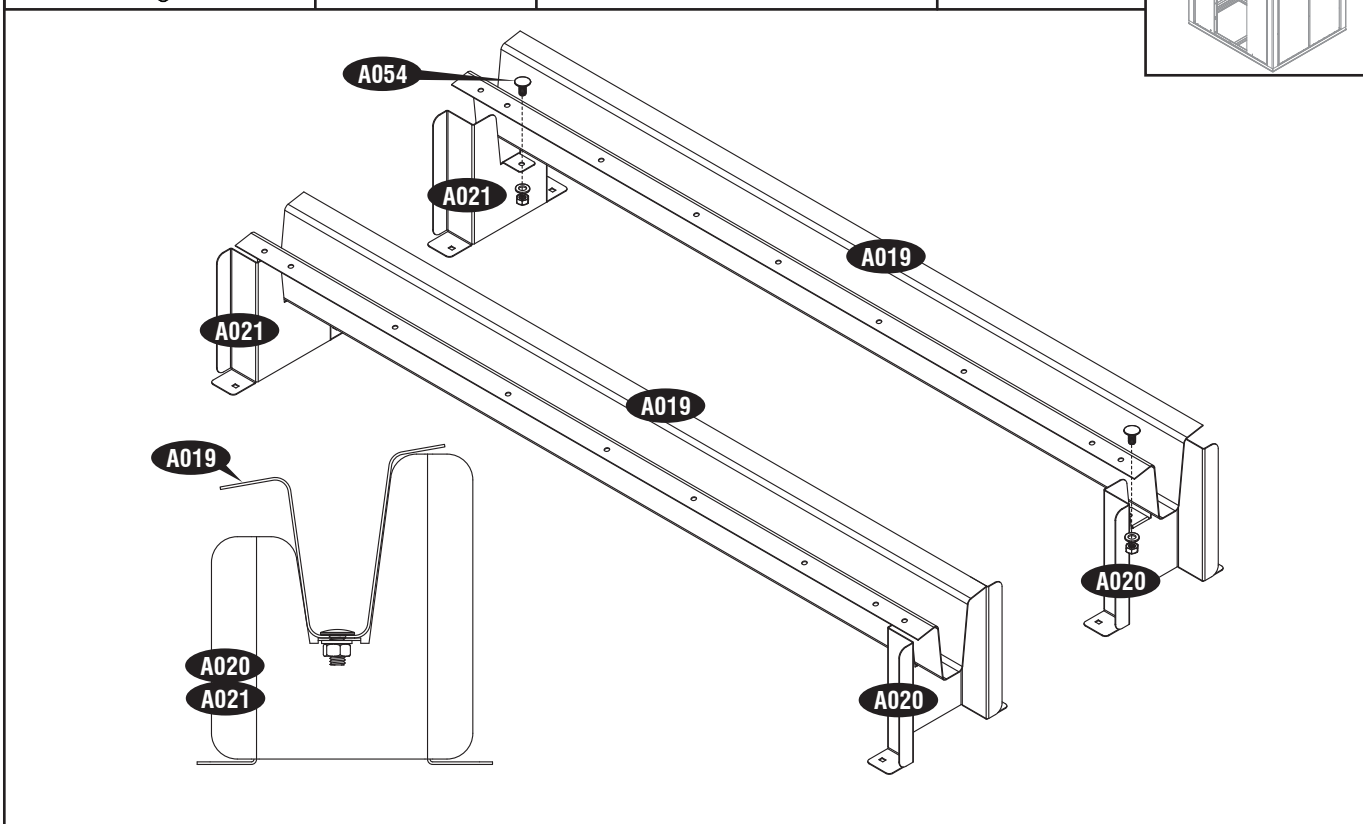
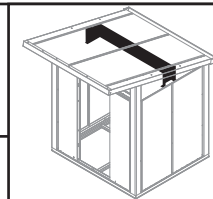
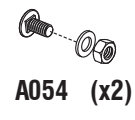
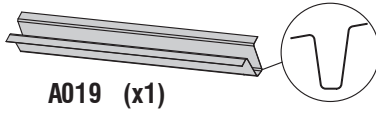
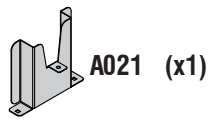

11

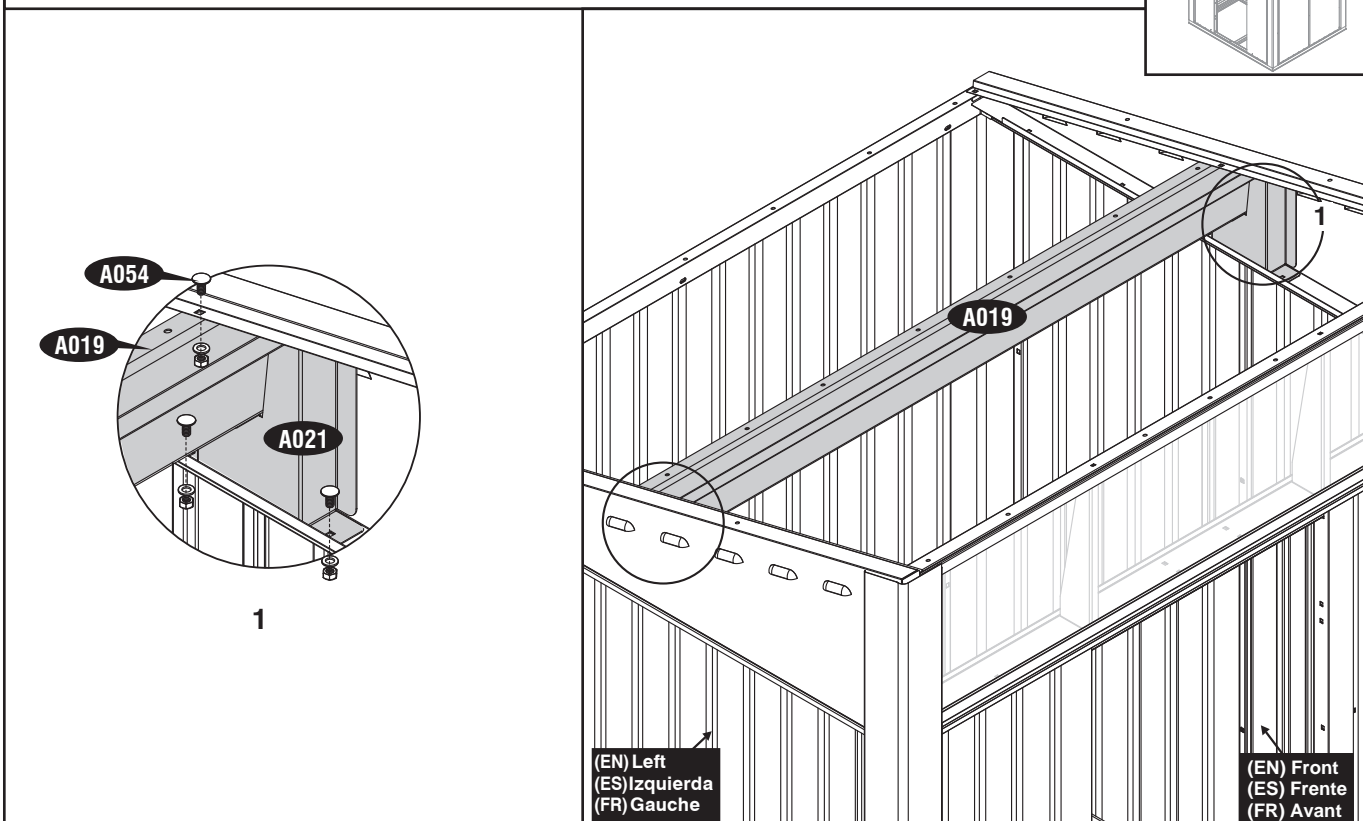
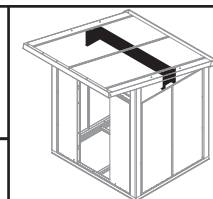

(EN) Left
(ES) Izquierda
(FR) Gauche

(EN) Front
(ES) Frente
(FR) Avant

12

A022 (x1)

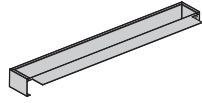

A054 (x2)

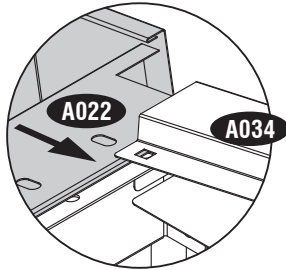
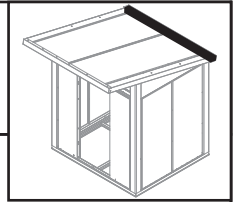

1

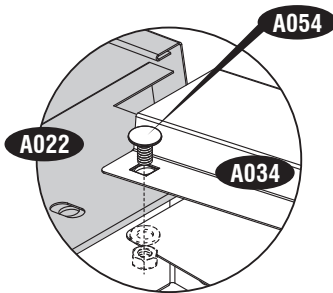

2

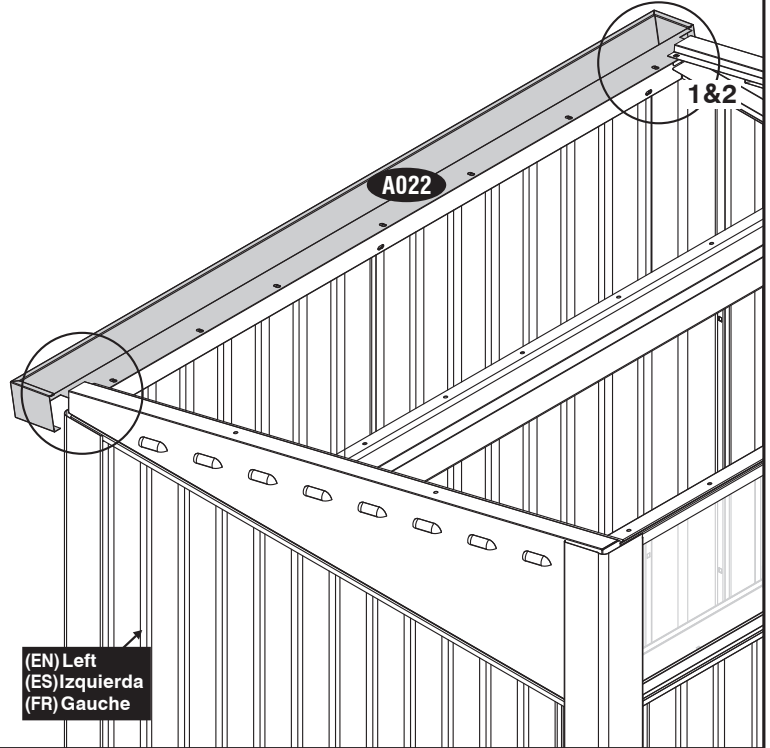

(EN) Left
(ES) Izquierda
(FR) Gauche

13

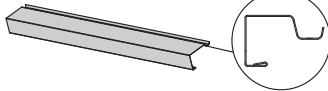

A024 (x1)

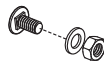

A054 (x2)



S2 (x1)

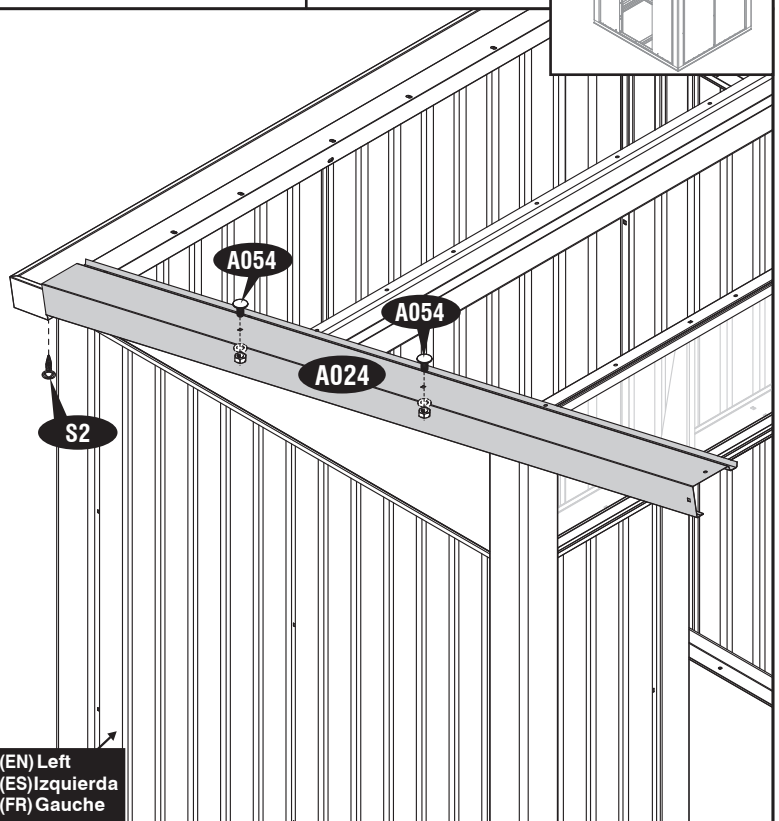
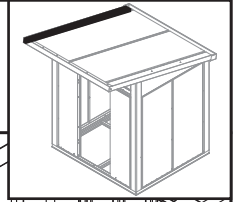

(EN) Left
(ES) Izquierda
(FR) Gauche

29

14

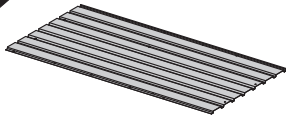

A041 (x1)

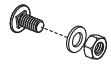

A054 (x11)

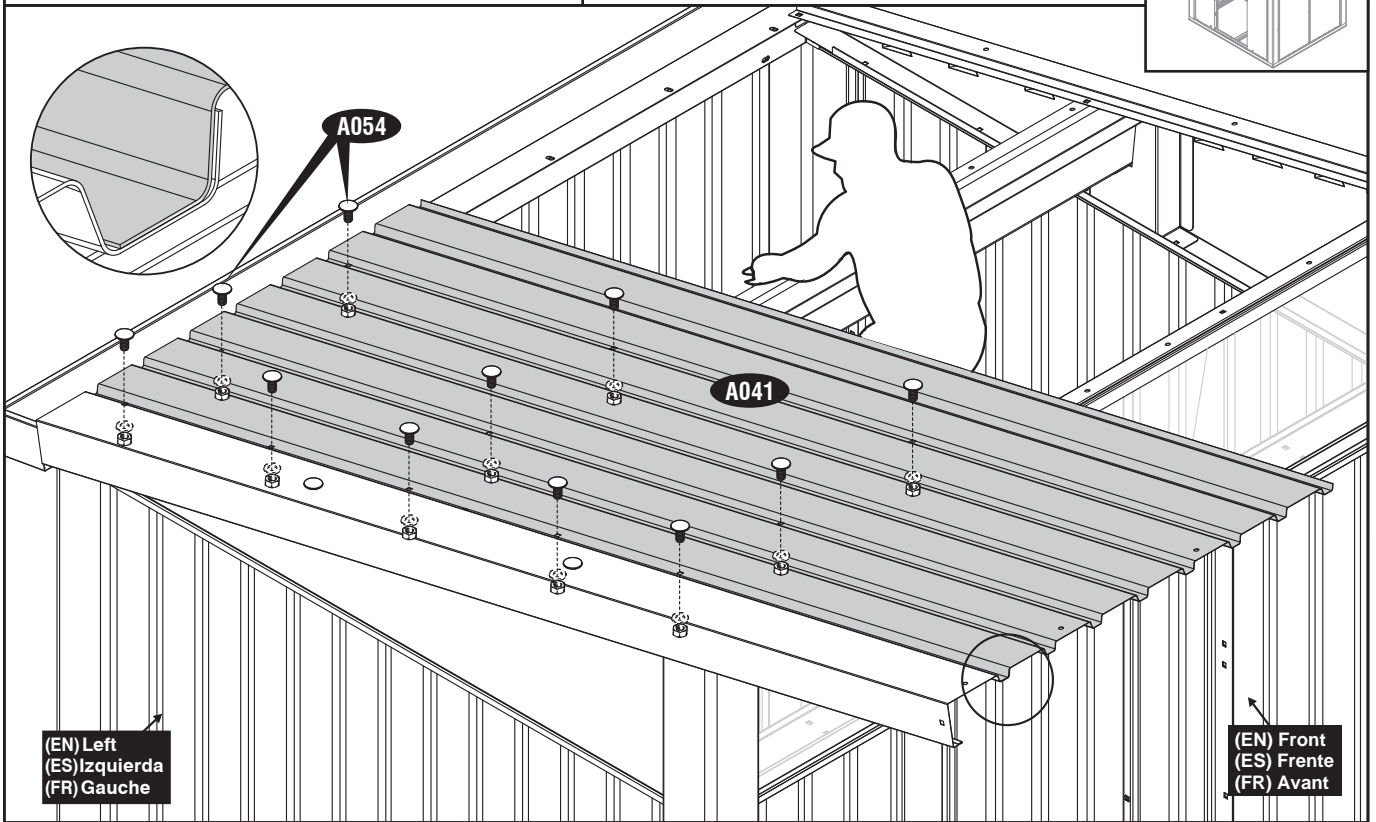
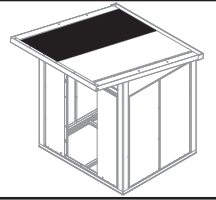

15

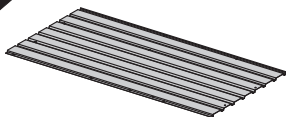

A041 (x1)

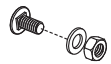

A054 (x11)

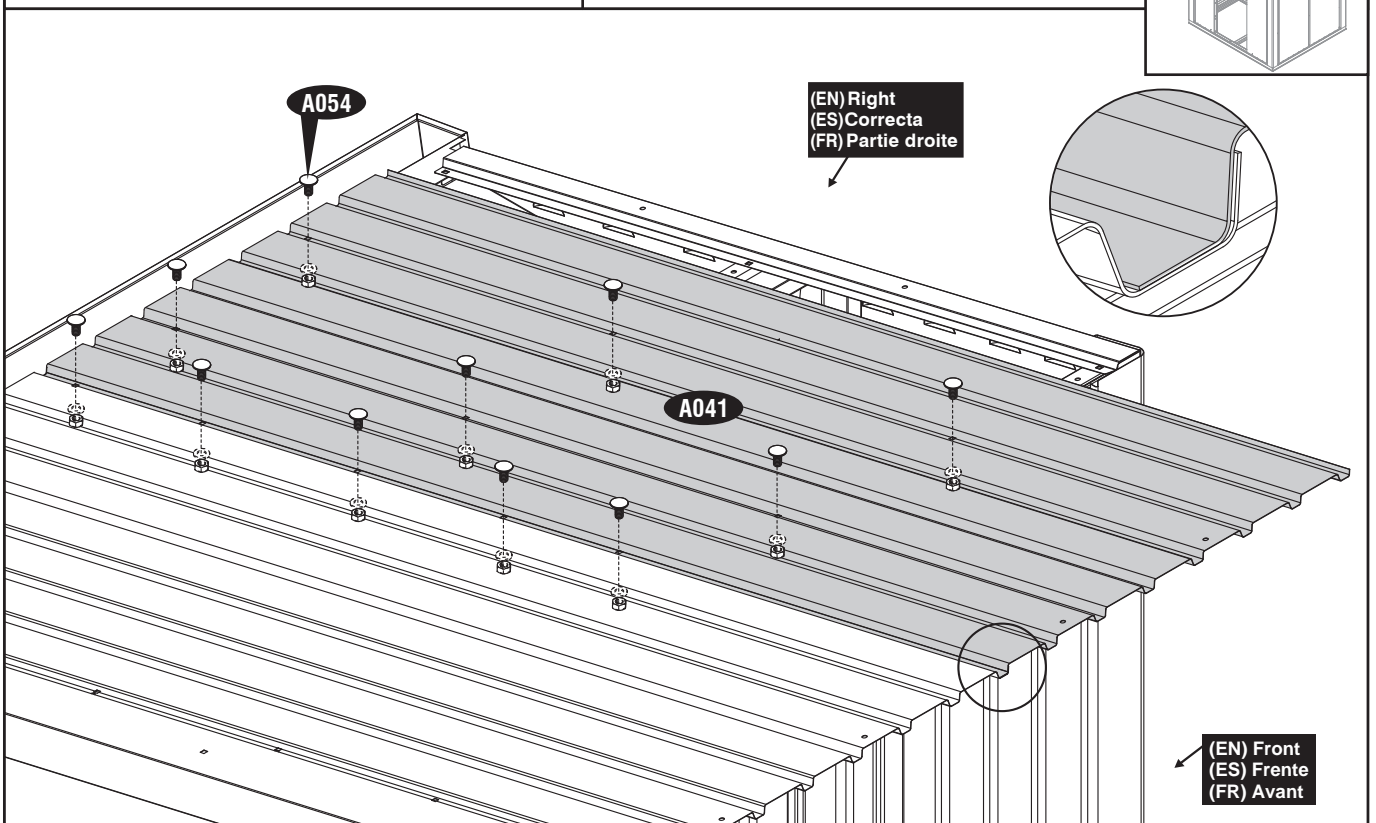
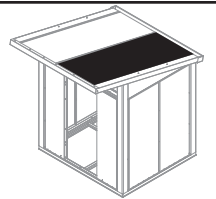

30

(EN) IMPORTANT: USE HAND GLOVES TO PREVENT INJURY.
(FR) IMPORTANT: UTILISER LES GANTS POUR PREVENIR LES ACCIDENTS.

(ES) IMPORTANTE: GUANTES DE MANO DE USO PARA PREVENIR LA HERIDA.

16

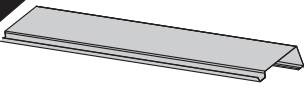

A025 (x1)



A054 (x7)



S2 (x1)

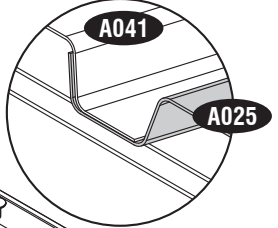
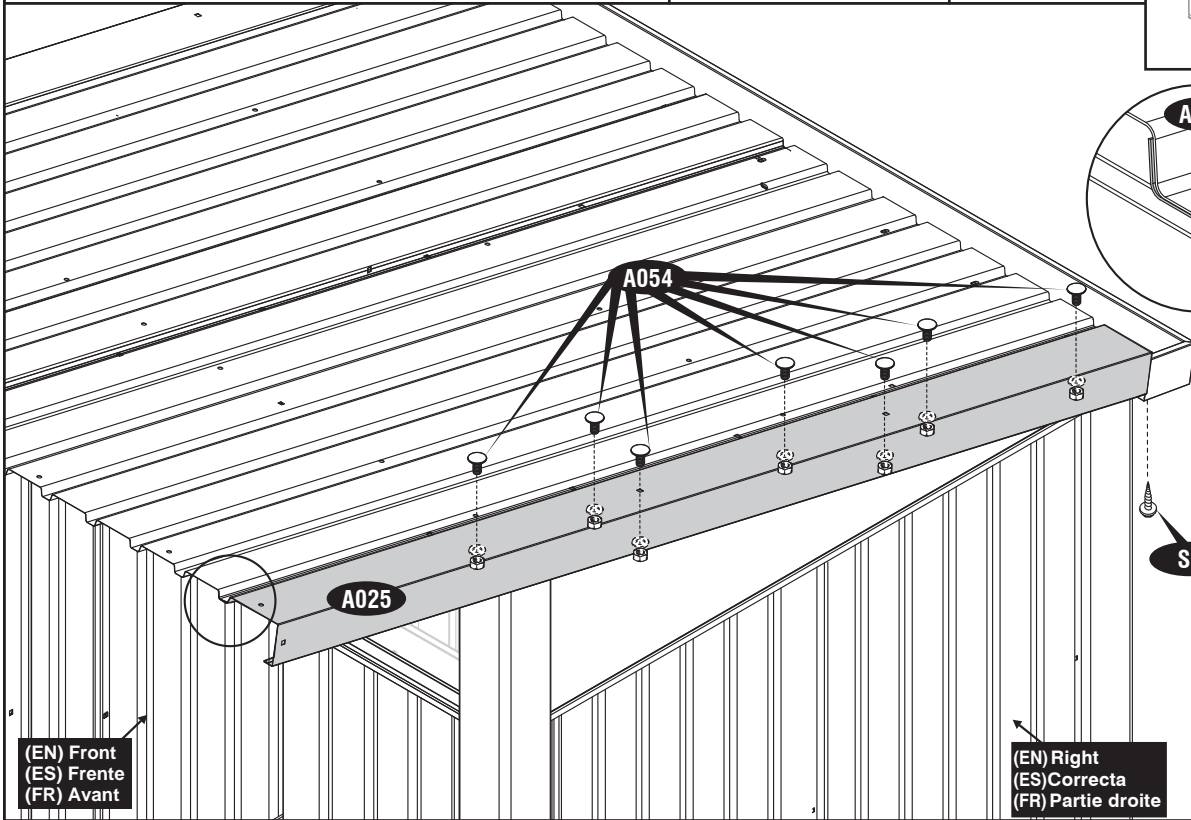
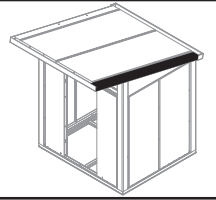

(EN) Front
(ES) Frente
(FR) Avant

(EN) Right
(ES) Correcta
(FR) Partie droite

17

A023 (x1)

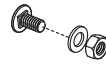
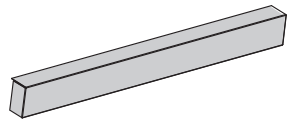

A054 (x8)

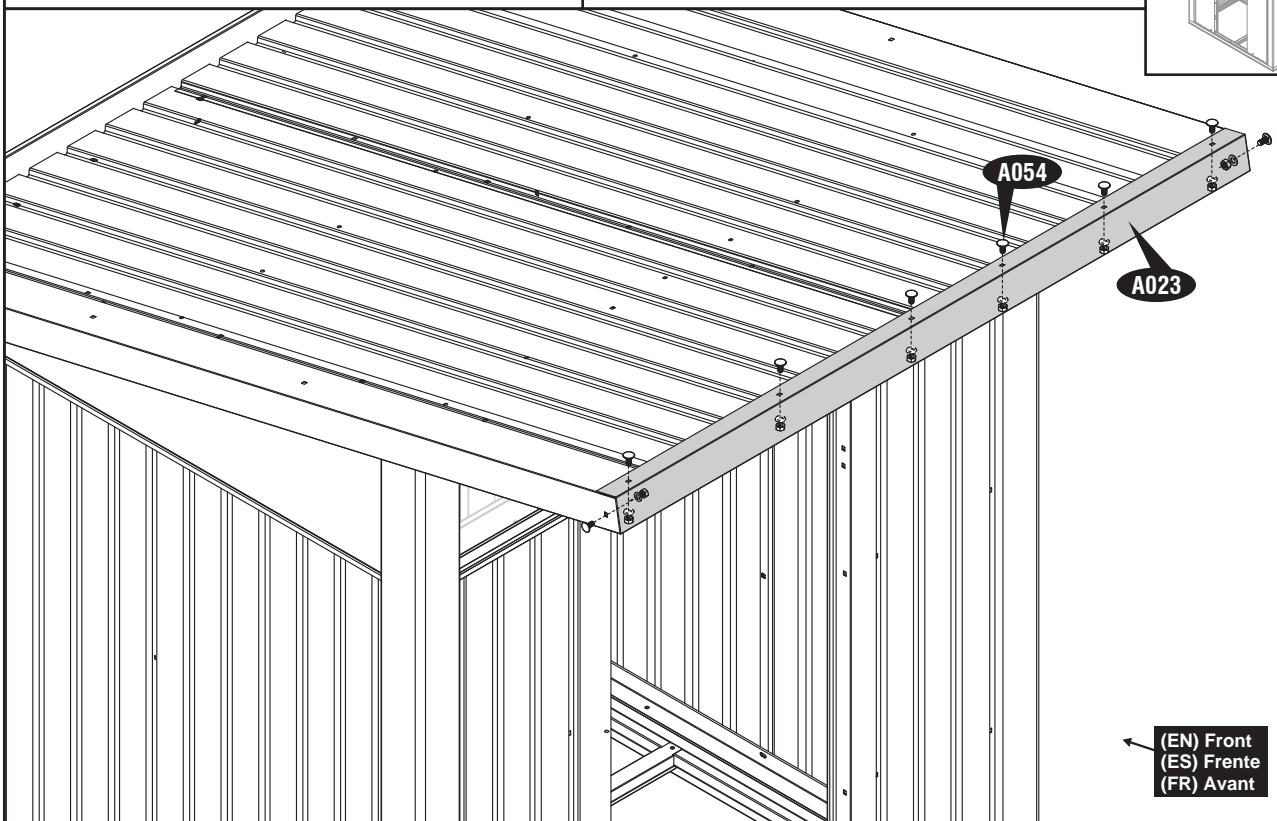
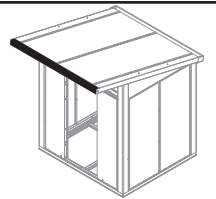

(EN) Front
(ES) Frente
(FR) Avant

31

(EN) IMPORTANT: USE HAND GLOVES TO PREVENT INJURY.
(FR) IMPORTANT: UTILISER LES GANTS POUR PREVENIR LES ACCIDENTS.

(ES) IMPORTANTE: GUANTES DE MANO DE USO PARA PREVENIR LA HERIDA.

18

A029 (x1)

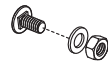
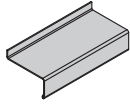

A055 (x4)

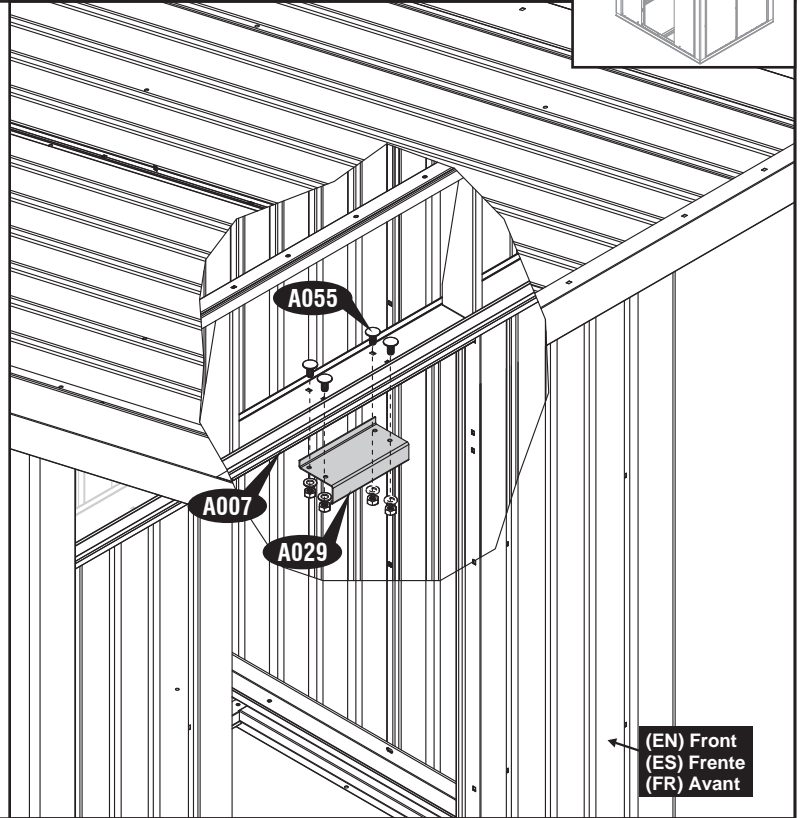
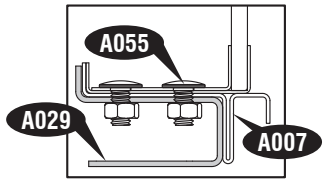
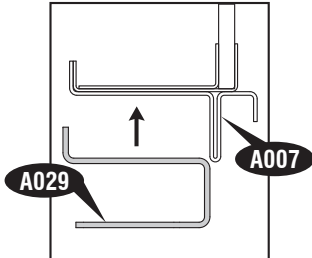
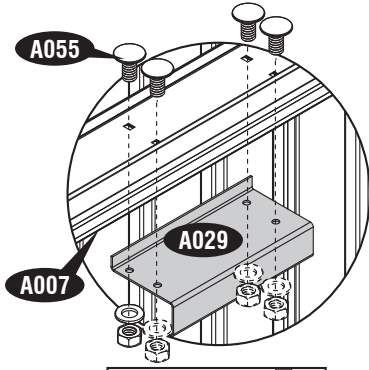
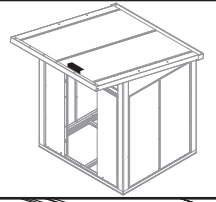

(EN) Front
(ES) Frente
(FR) Avant

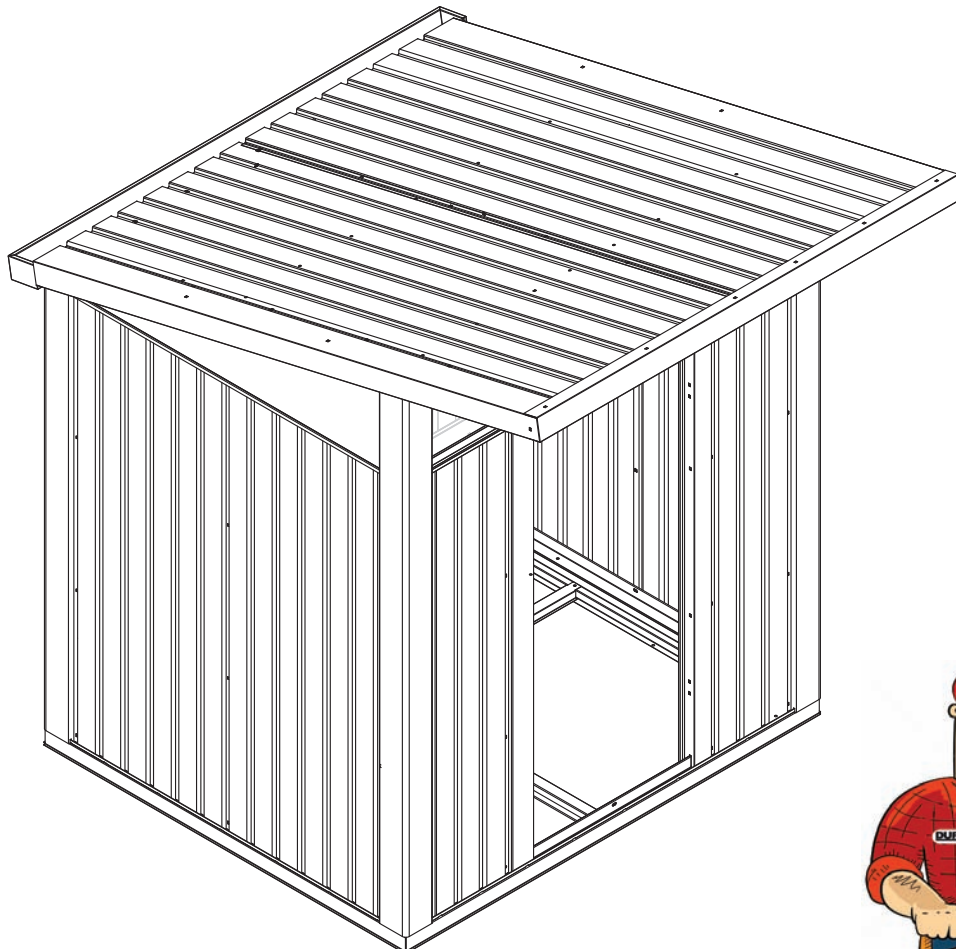

32

(EN) IMPORTANT: USE HAND GLOVES TO PREVENT INJURY.
(FR) IMPORTANT: UTILISER LES GANTS POUR PREVENIR LES ACCIDENTS.

(ES) IMPORTANTE: GUANTES DE MANO DE USO PARA PREVENIR LA HERIDA.

(EN) Shed Assembly on Concrete Foundation
(ES) Montaje de galpón en concreto de la Fundación
(FR) Assemblée de hangar sur une fondation en béton

(EN) Parts needed
(ES) Las partes necesitaron
(FR) Pièces nécessaires

(EN)CODE	(EN)QTY
(ES)CODE	(ES)QTY
(FR)CODE	(FR)QTÉ
S8	14
F1	14

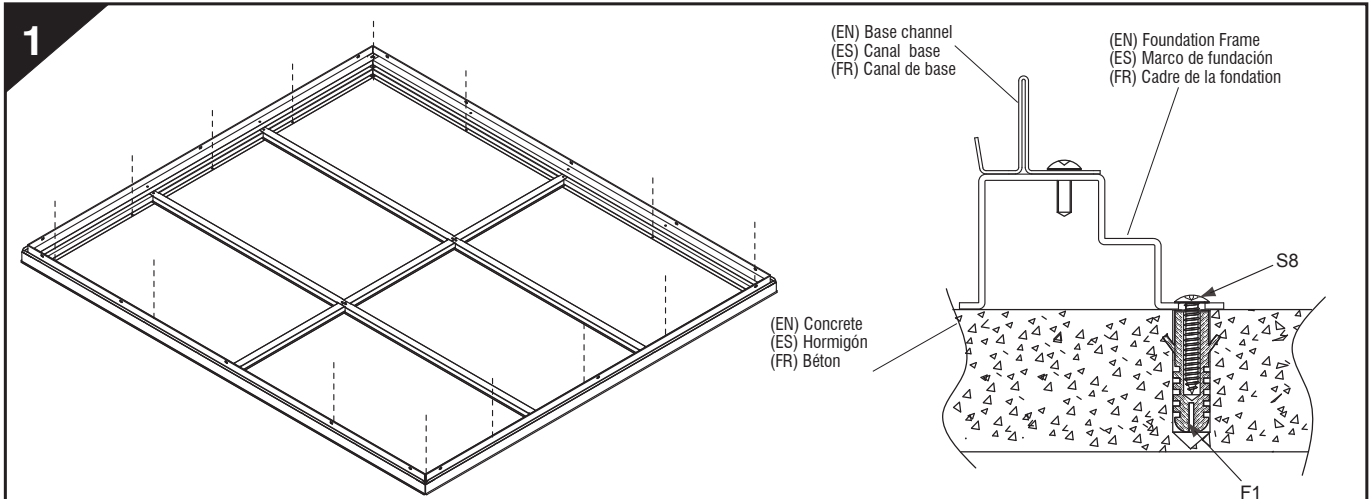

(EN) Note: To ensure that your shed will withstand high winds, you need to anchor on the concrete foundation. A concrete pad or a large size concrete patio stone squares is recommended for suitable floor base. Make sure it is firm and level and will allow drainage away from the site. Make a level concrete foundation, that has an outside dimension of 72" x 78 1/2" (1828mm x 1995mm). For a concrete pad base, prepare a level bed for a firm footing layer of crushed stone. The concrete pad should then be poured to a thickness of 4 inches (100mm) to 5 inches (125mm). Allow to dry thoroughly for at least 48 hours. Manufacturer is not responsible for the choice and construction of the foundation. Align the shed, mark the concrete at the holes in the Foundation Profiles and drill concrete with suitable concrete bit to accept Dia 6mm wall plug.

(ES) Nota: Para asegurar que su vertiente soportará vientos, usted necesitó anclar en la Fundación concreta. Una plataforma de concreto o un plazas piedra de hormigón patio de gran tamaño se recomienda para base de piso adecuado. Asegúrese de que esté firme y nivelado y permitirá el drenaje lejos del sitio. Hacer la base de una nivel base de hormigón, que tiene una dimensión exterior de 72" x 78 1/2" (1828mm x 1995mm). Para una plataforma de concreto, preparar una cama de nivel para una capa de apoyo firme de piedra machacada. La plataforma de concreto debe ser vertida luego en un espesor de 4 pulgadas (100mm) a 5 pulgadas (125mm). Deje para secar durante al menos 48 horas. Fabricante no es responsable de la elección y la construcción de la Fundación. Alinee el cobertizo, Marcar el concreto en los agujeros en la base y perforar concreto con poco cemento adecuado para aceptar enchufe de pared de 6 mm de diámetro.

(FR) Note: Pour vous assurer que votre abri résistera à des vents violents, vous aviez besoin d'ancler sur les fondations en béton. Une dalle de béton ou une pierre carrés de taille grand patio en béton est recommandée pour la base convenable étage. Assurez-vous qu'il est ferme et de niveau et permettra de drainage en dehors du site. Faire une fondation en béton niveau, qui a une dimension extérieure de 72" x 78 1/2" (1828mm x 1995mm). Pour une dalle de béton de base, préparez un lit de niveau pour une couche de base solide de pierres concassées. On verse ensuite la dalle en béton d'une épaisseur de 4 pouces (100mm) à 5 pouces (125mm). Laisser pour sécher complètement pendant au moins 48 heures. Référence du fabricant n'est pas responsable du choix et la construction de la Fondation. Aligner le hangar, Marquer le béton dans les trous de la base et percer le béton avec foret à béton adapté à accepter Dia prise murale 6mm.

(EN) Floor Options
(ES) Opción de piso
(FR) Option plancher

1

(EN) Plywood (Not included)
(ES) Contrachapado (No incluido)
(FR) Contreplaqué (Non fournies avec l'abri)

- (EN) Place the Exterior Grade (CDX) - 3/4" (19mm) Weather proof Marine grade plywood on top of the foundation. (Plywood not included.)
(ES) coloque el grado exterior (CDX) -3/4 "(19 mm) resistente a la intemperie contrachapado marino de grado en la parte superior de la fundación (contrachapado no incluido).
(FR) placer le grade extérieur (CDX) -3/4 "(19mm) résistante aux intempéries de contreplaqué de qualité marine au-dessus de la fondation. (contreplaqué non inclus)

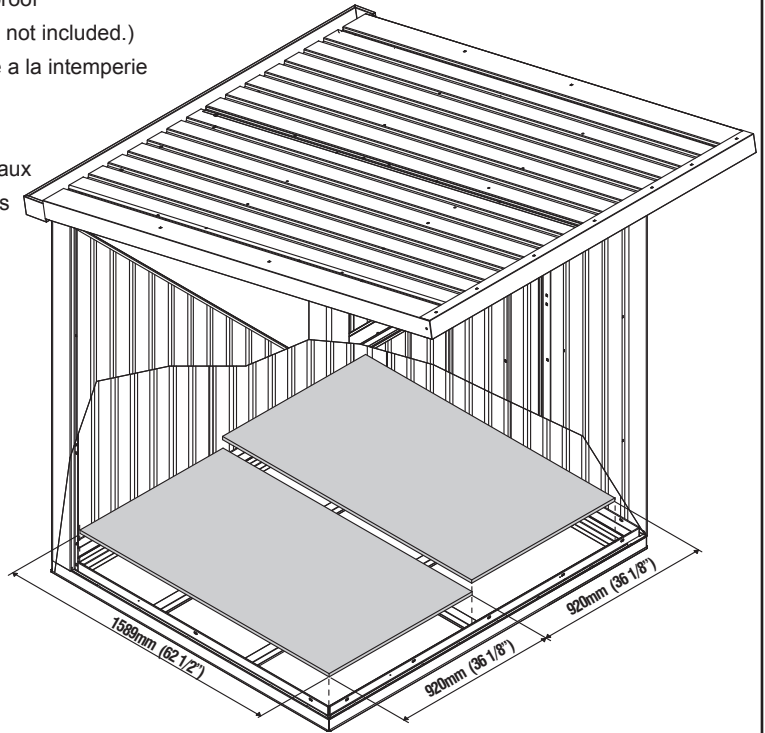

2

(EN) Concrete Floor (Not Included)
(ES) Piso de concreto (não incluído)
(FR) Plancher de béton (non inclus)

- (EN) Concrete to be filled up to this level
(ES) Hormigón para ser lled hasta este nivel
(FR) Béton pour être lled jusqu'à ce niveau

(EN) Concrete
(ES) Hormigón
(FR) Béton

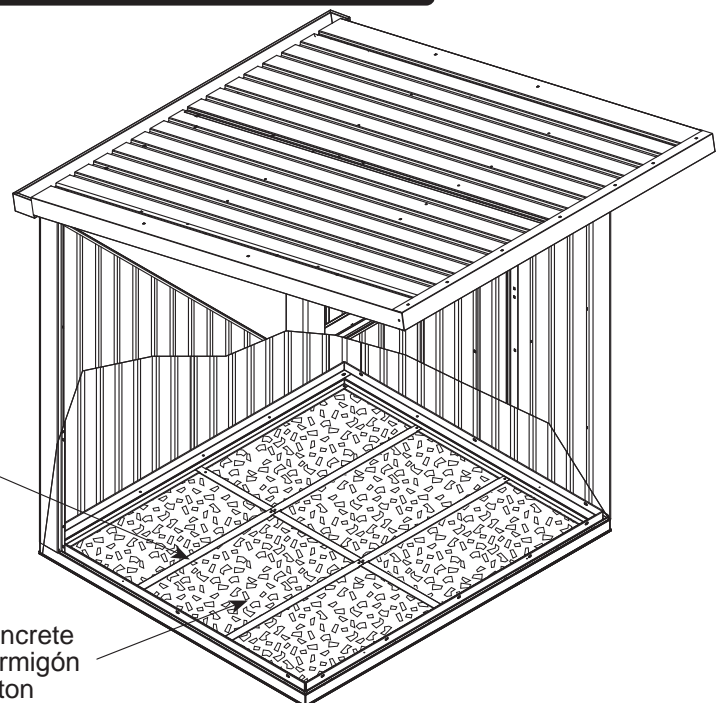



5

(EN) Door
(ES) La puerta
(FR) Porte



(EN) Parts needed
(ES) Las partes necesarias
(FR) Pièces nécessaires

(EN)CODE (ES)CODE (FR)CODE	(EN)QTY (ES)QTY (FR)QTÉ	(EN)CODE (ES)CODE (FR)CODE	(EN)QTY (ES)QTY (FR)QTÉ	(EN)CODE (ES)CODE (FR)CODE	(EN)QTY (ES)QTY (FR)QTÉ
A030	1	A044	1	A018	1
A032	1	A045	1	A050	1
A042	1	A048	1	A054	4
A043	1	A049	1	A056	1
				S2	12

1

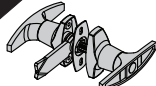

A042 (x1)

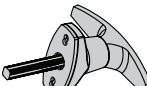

(x1)

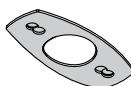

(x1)

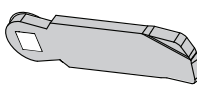

(x1)



(x2)



(x2)

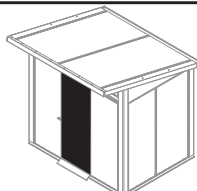

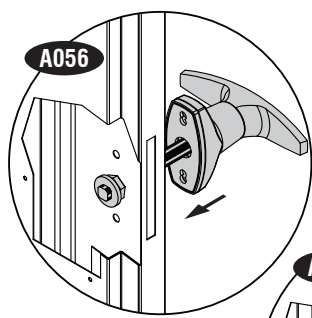

A056

1

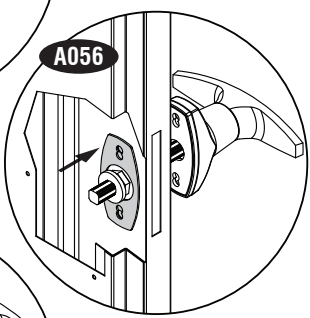

A056

2

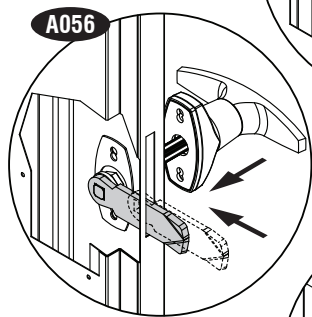

A056

3

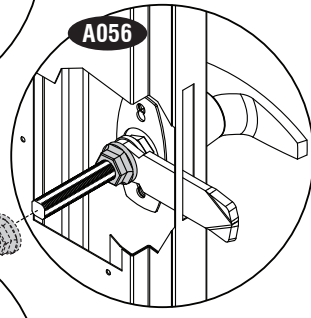

A056

4

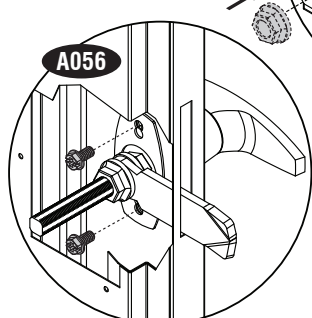

A056

5

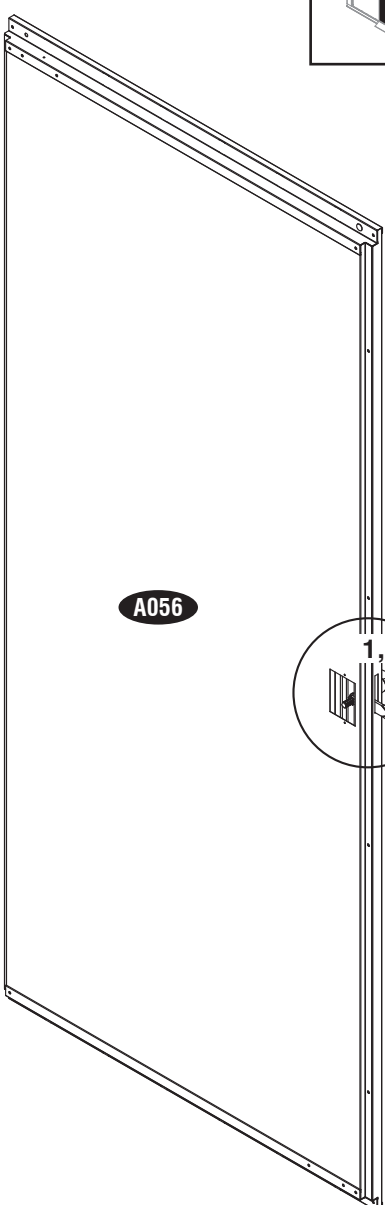

A056

1,2,3,4&5

2

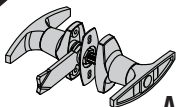

A042

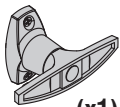

(x1)



(x2)



S2 (x6)

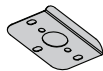

A032 (x1)

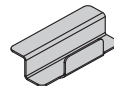

A030 (x1)

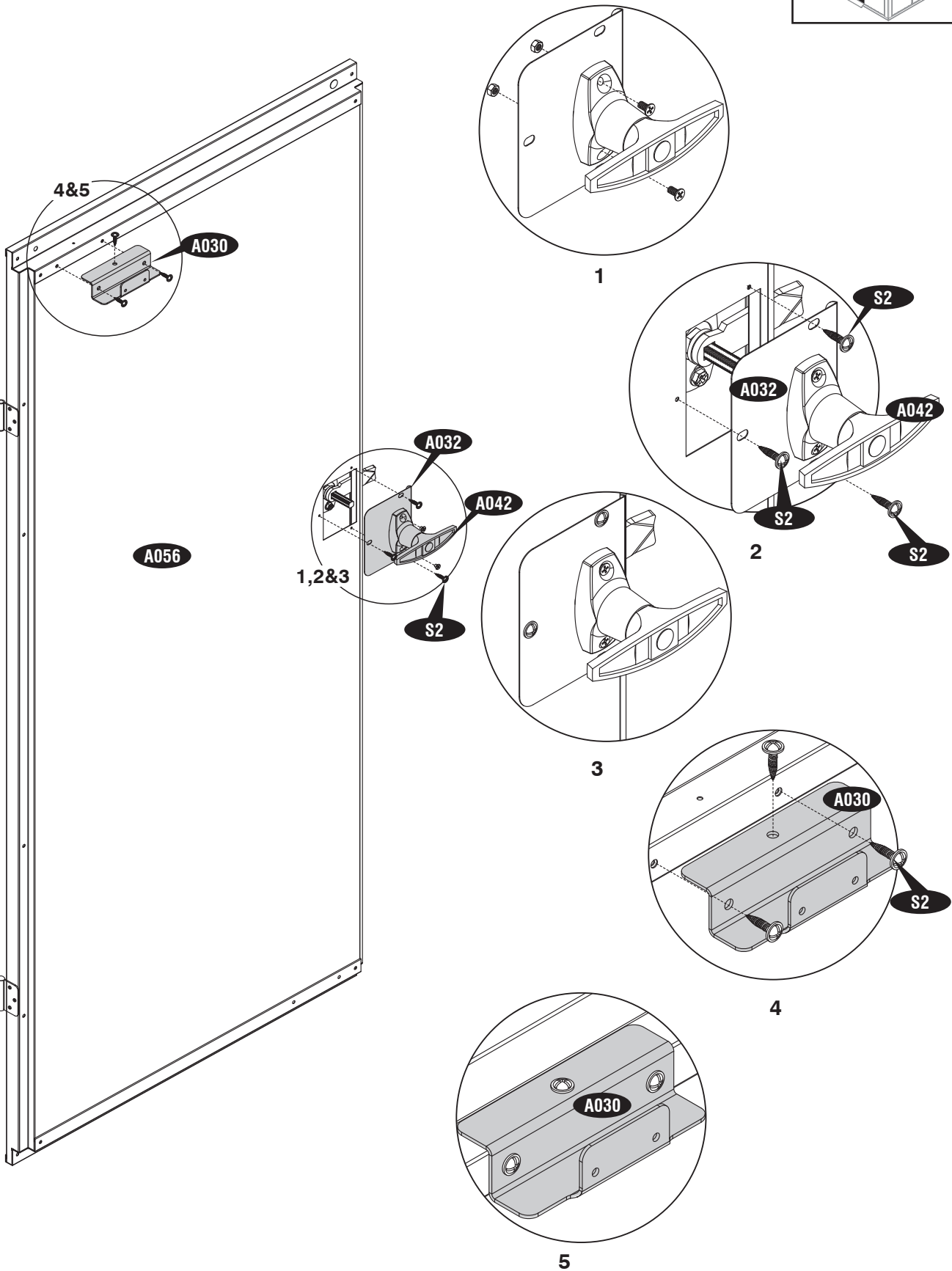
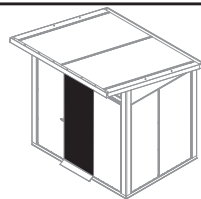

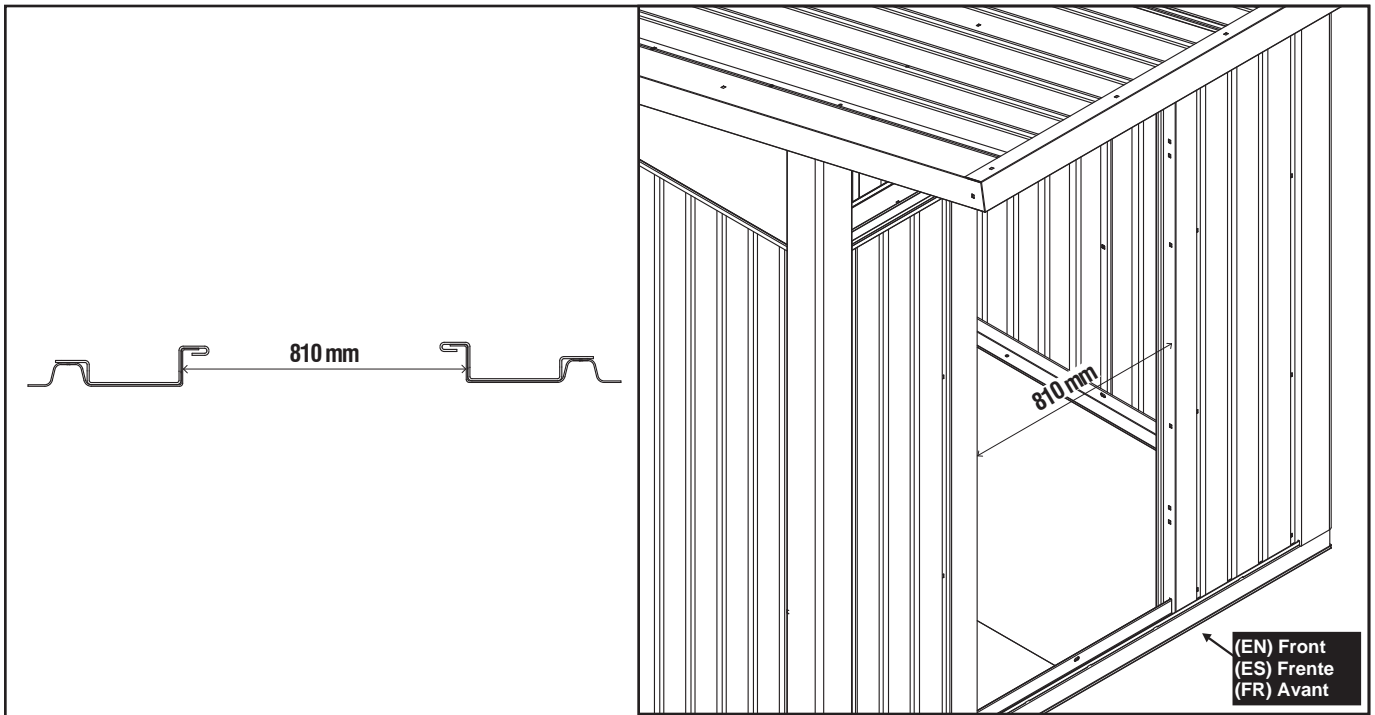

(EN) Note : Adjust the front wall to ensure the door vertical gap 810 mm.
 (ES) Pozor :Ajustar la pared delantera para asegurar la separación vertical de puerta 810 mm.
 (FR) Note: Ajuster la paroi frontale pour assurer l'écart vertical de porte 810 mm



(EN) Fully tighten all the bolts & nuts now !
 (ES) Apriete todos los pernos & tuercas ahora!
 (FR) Serrer tous les boulons & écrous maintenant !

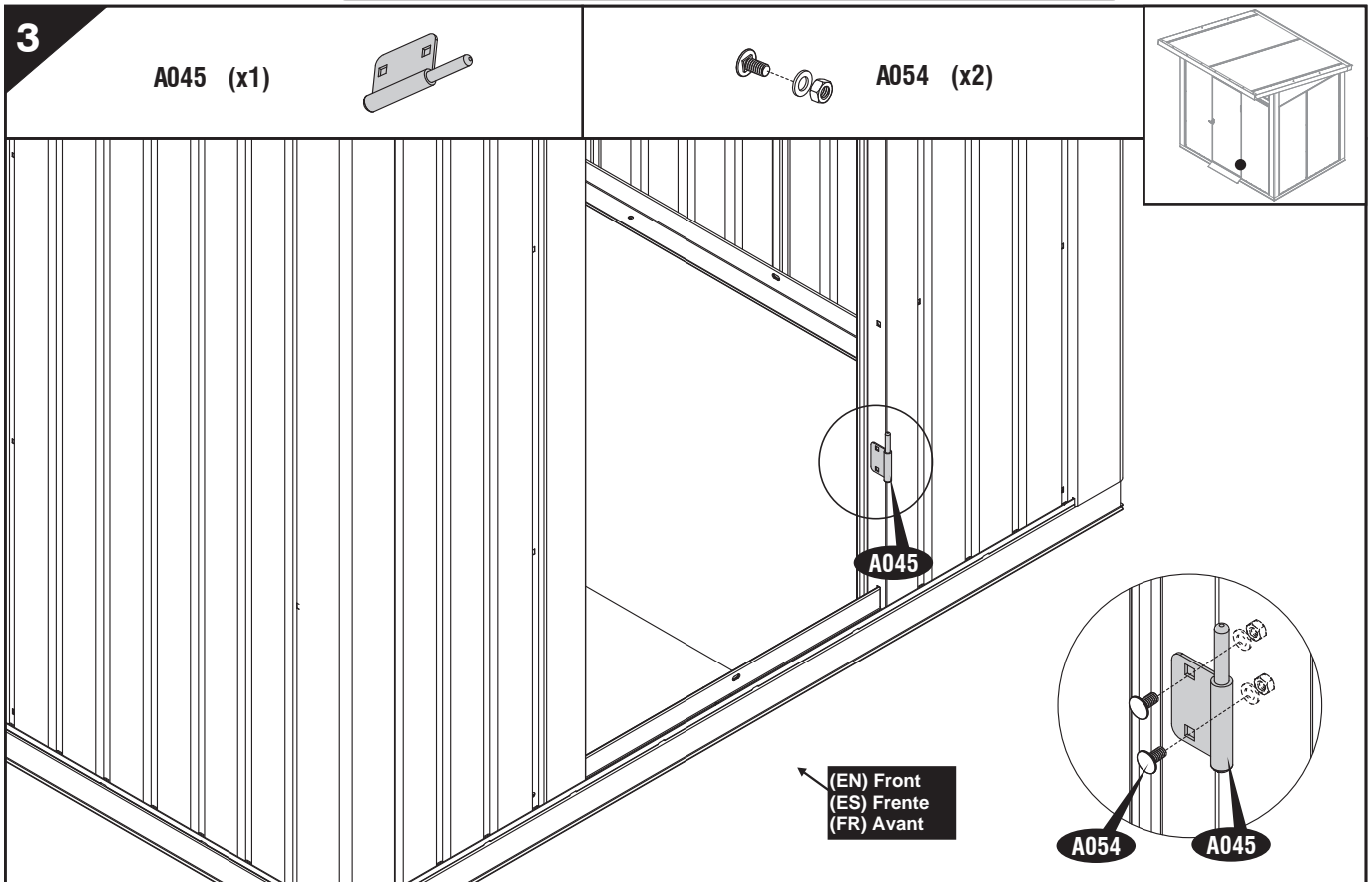

4

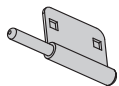

A044 (x1)

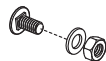

A054 (x2)

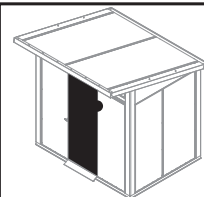

1

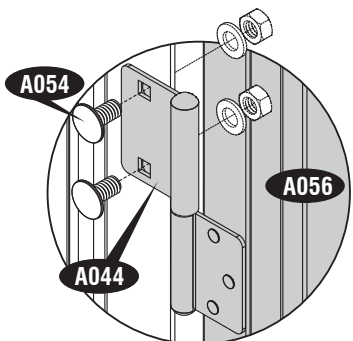

2

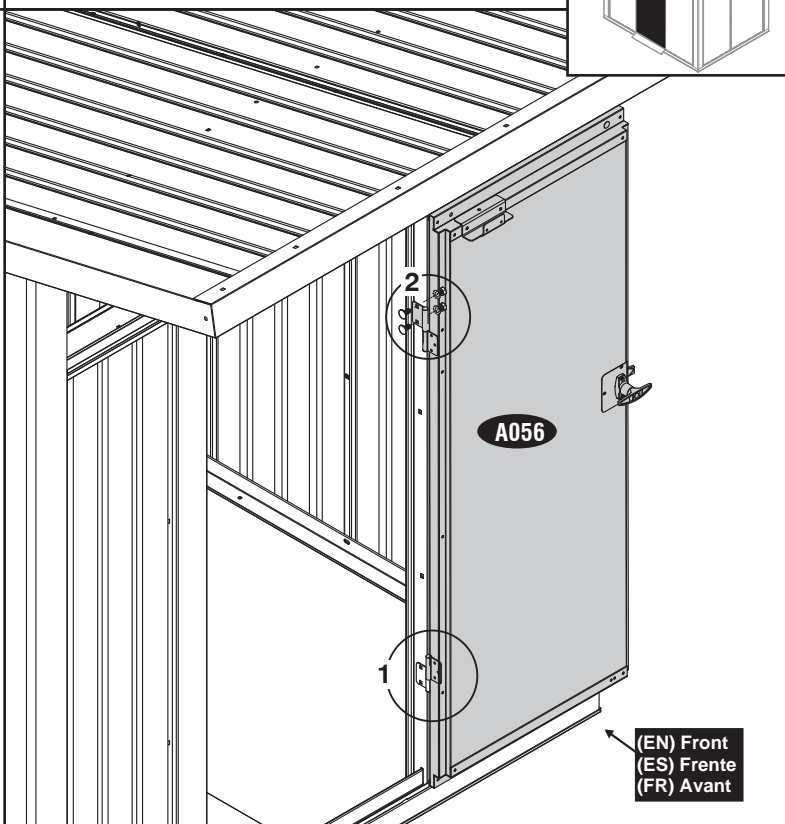

(EN) Front
(ES) Frente
(FR) Avant

5

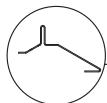

A018 (x1)

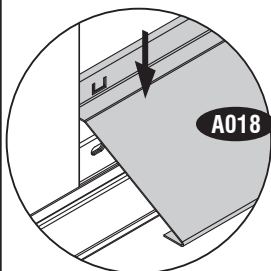
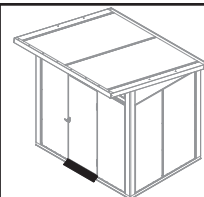

1

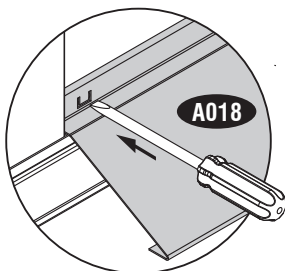

2

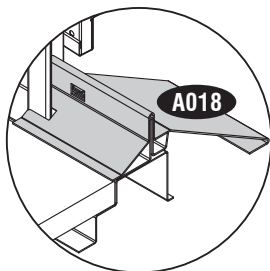

A018

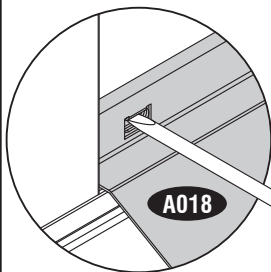

3

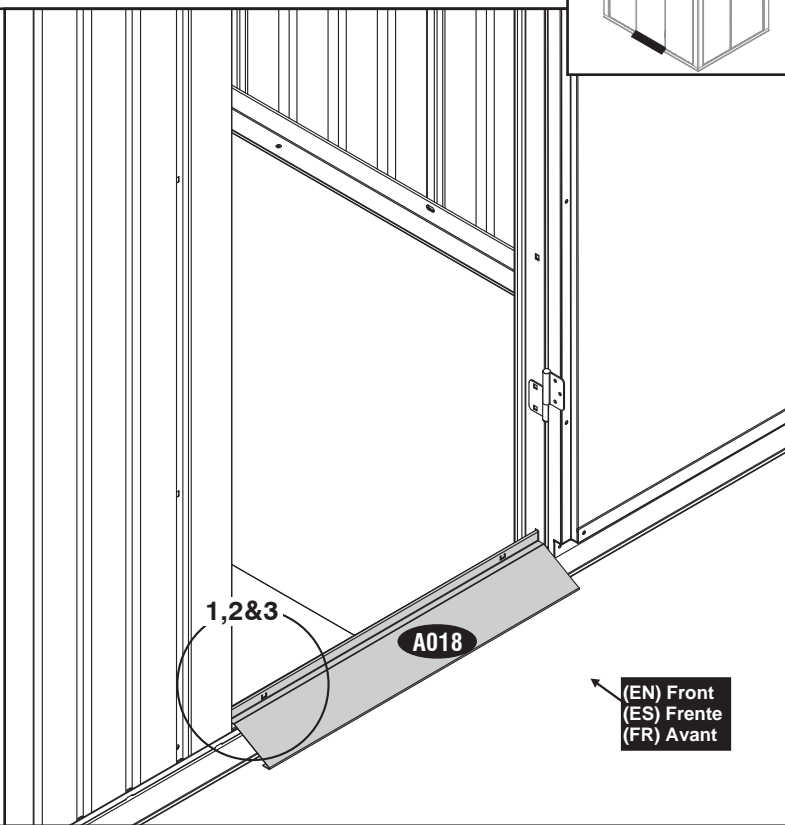

(EN) Front
(ES) Frente
(FR) Avant

6

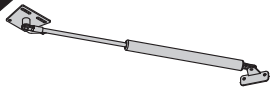

A043 (x1)



S2 (x6)

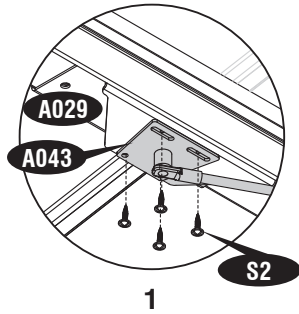
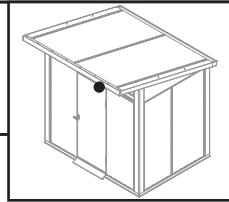

1

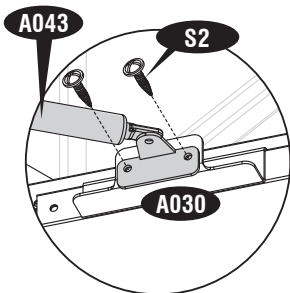

2

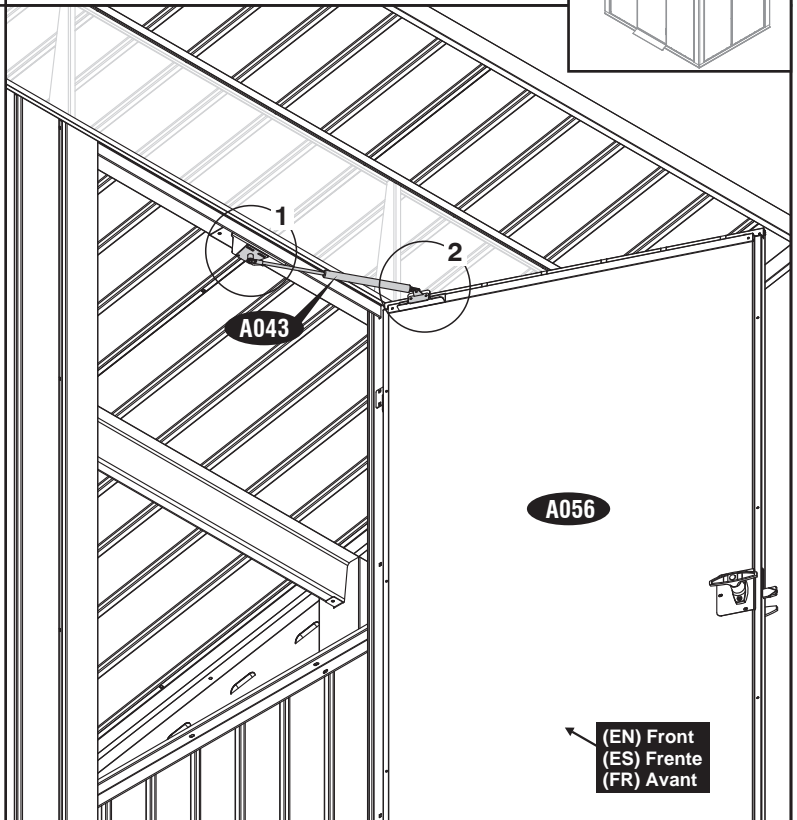

(EN) Front
(ES) Frente
(FR) Avant

7



A048 (x1)



A050 (x1)



A049 (x1)

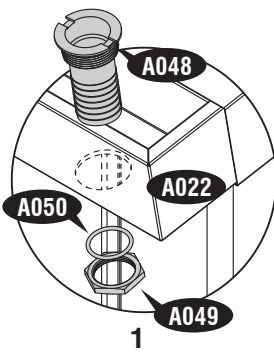
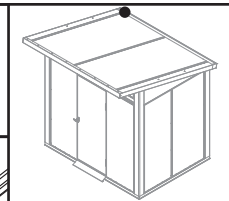

1

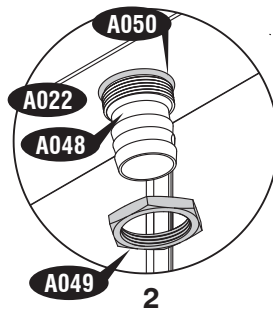

2

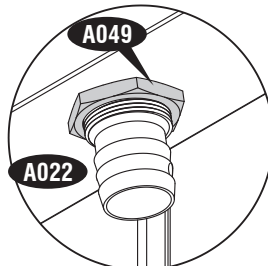

3

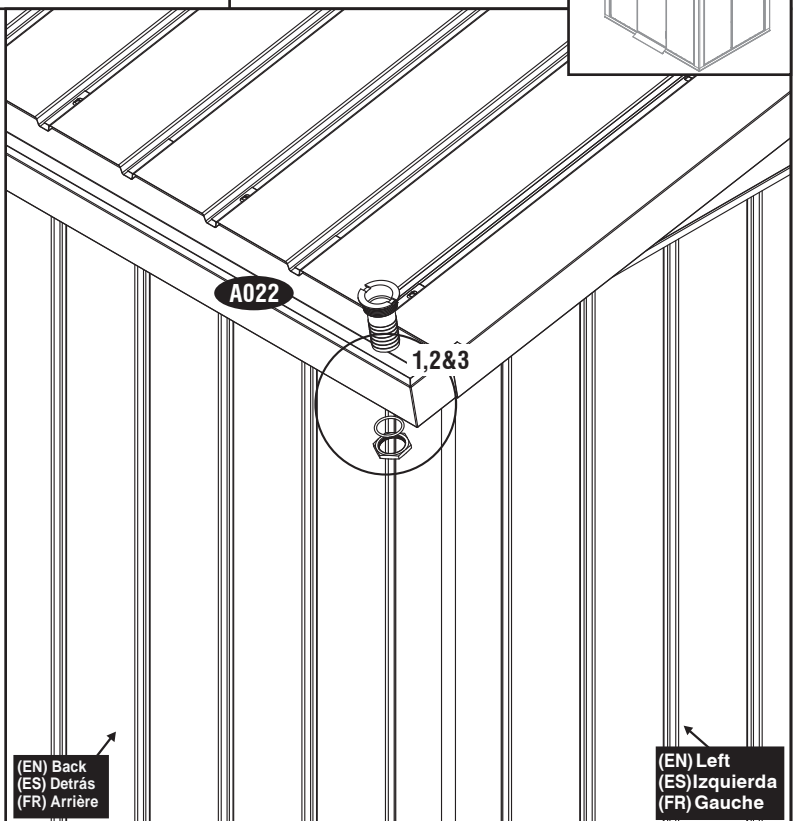

(EN) Back
(ES) Detrás
(FR) Arrière

(EN) Left
(ES) Izquierda
(FR) Gauche



(EN) Important Warranty Information

(ES) Información importante sobre la garantía

(FR) Informations Importantes Concernant La Garantie

(EN)The 'DURAMAX' shed has been tested and passed high wind loads in a controlled laboratory environment when installed with the high wind installation guidelines. Natural high wind areas create wind at unpredictable speeds that are very difficult to capture accurately by location. As such we cannot guarantee the performance of the shed in these extreme situations

(ES) El cobertizo ' DURAMAX ' ha sido probado y aprobado cargas de viento en un entorno controlado de laboratorio cuando se instala con las pautas de instalación de vientos fuertes . Espacios naturales de vientos crean viento a velocidades impredecibles que son muy difíciles de capturar con precisión la ubicación. Como tal , no podemos garantizar el funcionamiento de la nave en

(FR)Le hangar ' DURAMAX ' a été testé et passé des charges de vent élevées dans un environnement de laboratoire contrôlé lorsqu'il est installé avec les directives d'installation de haute vent . Naturelles, les zones de vents forts créent vent à des vitesses imprévisibles qui sont très difficiles à saisir avec précision par emplacement . En tant que tel , nous ne pouvons pas garantir la performance de la foule dans ces situations

(EN) “We recommend to clear snow from the Roof top after each Snowfall.”

A snow depth of more than 10 cm can become hazardous!

(ES) “Se recomienda limpiar la nieve de la azotea después de ca da nevada.”

Una profundidad de nieve de más de 10 cm puede llegar a ser peligrosa!

(FR) “Nous recommandons d’enlever la neige du Toit après chaque Enneigement.”

Une épaisseur de neige de plus de 10 cm peut devenir dangereux!

(EN) “For dismantling the Shed, Customer has to follow instructions manual in reverse direction.”

(ES) “Para el desmantelamiento de la nave, cliente tiene que seguir instrucciones en sentido contrario”.

(FR) “Pour le démantèlement du hangar, client doit suivre le manuel d'instructions dans le sens inverse.”



(EN) Congratulations!

(EN) We hope you enjoy your DuraMax Storage Shed!

(ES) Felicidades!

(ES) Esperamos que disfrute su cobertizo de almacenaje para DuraMax!

(FR) Félicitations !

(FR) Nous espérons que vous apprécierez votre cabanon de DuraMax!

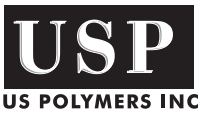

U.S. Polymers, Inc.
1057 S. Vail Ave
Montebello, CA 90640,
United States of America

www.duramaxbp.com