

PRO-FORM[®]

135 CSX

www.proform.com

Model No. PFEX51915.0

Serial No. _____

Write the serial number in the space above for reference.

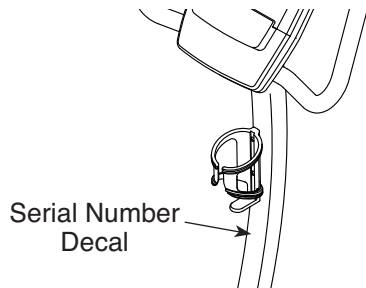

ACTIVATE YOUR WARRANTY

To register your product and activate your warranty today, go to www.proformservice.com/registration.

CUSTOMER CARE

For service at any time, go to www.proformservice.com.

Or call 1-888-533-1333
Mon.–Fri. 6 a.m.–6 p.m. MT
Sat. 8 a.m.–12 p.m. MT

Please do not contact the store.

⚠ CAUTION

Read all precautions and instructions in this manual before using this equipment. Keep this manual for future reference.

USER'S MANUAL

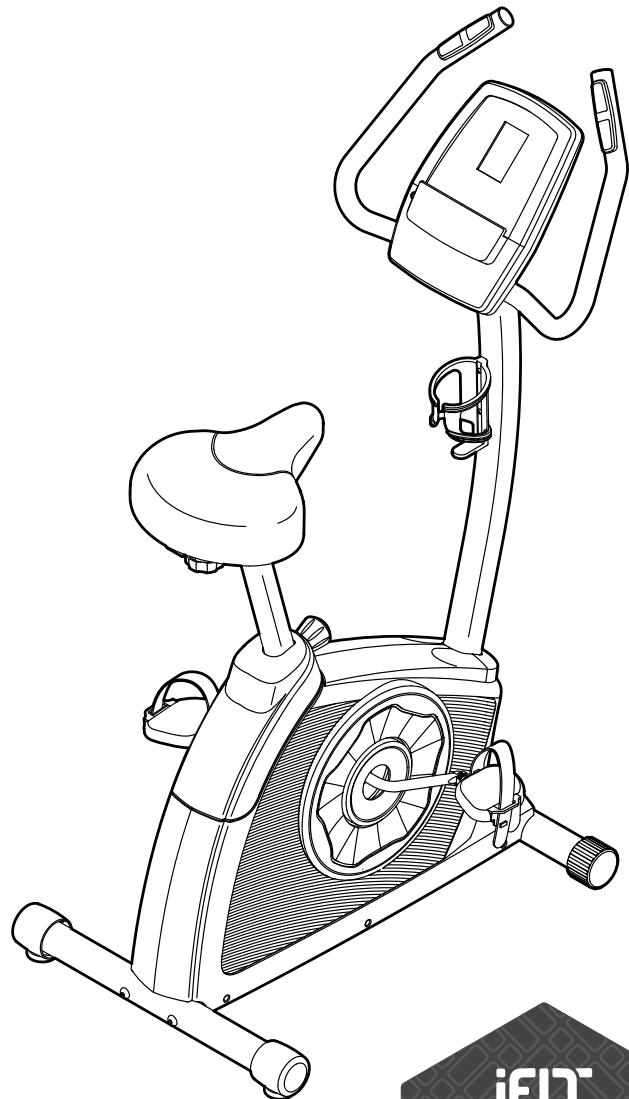
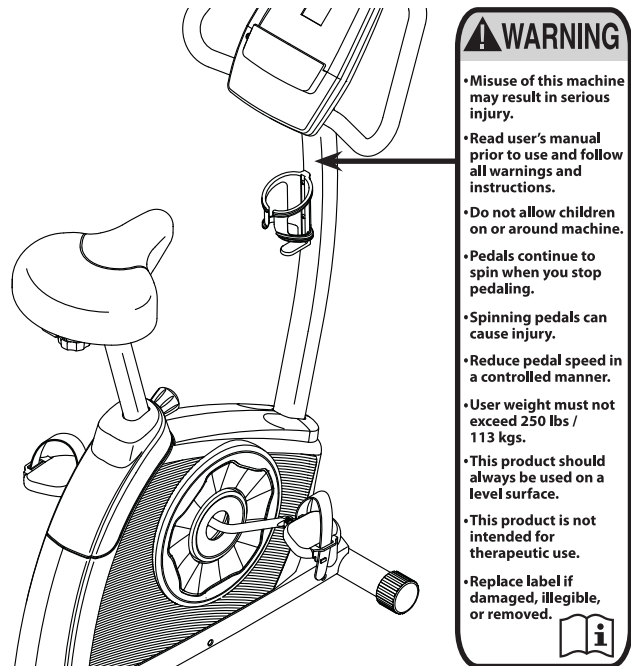

TABLE OF CONTENTS

WARNING DECAL PLACEMENT	2
IMPORTANT PRECAUTIONS	3
BEFORE YOU BEGIN	5
PART IDENTIFICATION CHART	6
ASSEMBLY	7
HOW TO USE THE EXERCISE BIKE	13
FCC INFORMATION	18
MAINTENANCE AND TROUBLESHOOTING	19
EXERCISE GUIDELINES	21
PART LIST	22
EXPLODED DRAWING	23
ORDERING REPLACEMENT PARTS	Back Cover
LIMITED WARRANTY	Back Cover

WARNING DECAL PLACEMENT

This drawing shows the location(s) of the warning decal(s). **If a decal is missing or illegible, see the front cover of this manual and request a free replacement decal. Apply the decal in the location shown.** Note: The decal(s) may not be shown at actual size.



IMPORTANT PRECAUTIONS

⚠ WARNING: To reduce the risk of serious injury, read all important precautions and instructions in this manual and all warnings on your exercise bike before using your exercise bike. ICON assumes no responsibility for personal injury or property damage sustained by or through the use of this product.

1. It is the responsibility of the owner to ensure that all users of the exercise bike are adequately informed of all precautions.
2. Before beginning any exercise program, consult your physician. This is especially important for persons over age 35 or persons with pre-existing health problems.
3. The exercise bike is not intended for use by persons with reduced physical, sensory, or mental capabilities or lack of experience and knowledge, unless they are given supervision or instruction about use of the exercise bike by someone responsible for their safety.
4. Use the exercise bike only as described in this manual.
5. The exercise bike is intended for home use only. Do not use the exercise bike in a commercial, rental, or institutional setting.
6. Keep the exercise bike indoors, away from moisture and dust. Do not put the exercise bike in a garage or covered patio, or near water.
7. Place the exercise bike on a level surface with at least 2 ft. (0.6 m) of clearance around the exercise bike. To protect the floor or carpet from damage, place a mat under the exercise bike.
8. Inspect and properly tighten all parts each time the exercise bike is used. Replace any worn parts immediately.
9. Keep children under age 13 and pets away from the exercise bike at all times.
10. Wear appropriate clothes while exercising; do not wear loose clothes that could become caught on the exercise bike. Always wear athletic shoes for foot protection.
11. The exercise bike should not be used by persons weighing more than 250 lbs. (113 kg).
12. Be careful when mounting and dismounting the exercise bike.
13. Always keep your back straight while using the exercise bike; do not arch your back.
14. The heart rate monitor is not a medical device. Various factors, including the user's movement, may affect the accuracy of heart rate readings. The heart rate monitor is intended only as an exercise aid in determining heart rate trends in general.
15. The exercise bike does not have a freewheel; the pedals will continue to move until the flywheel stops. Reduce your pedaling speed in a controlled way.
16. Over exercising may result in serious injury or death. If you feel faint, if you become short of breath, or if you experience pain while exercising, stop immediately and cool down.

PROTECT

YOUR FITNESS EQUIPMENT
WITH AN EXTENDED SERVICE PLAN

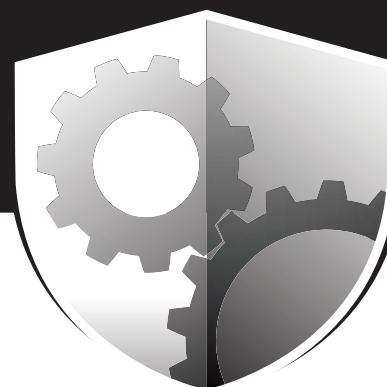

Your new fitness equipment is not an ordinary purchase; it is an investment in your health and well being for years to come.

As the leading provider of manufacturer's extended service plans, ICON strives to protect your equipment and your future.

Please review the following service plans and find one that best fits your needs.

PREVENTIVE MAINTENANCE SERVICE PLANS

Equipment Price	3-Year Plan	5-Year Plan
\$0.00 to \$1000.00	\$199.99	\$289.99
\$1001.00 to \$1500.00	\$259.99	\$379.99
\$1501.00 to \$2500.00	\$339.99	\$489.99
(Bikes/Systems Only) \$0.00 to \$2500.00	\$139.99	NA

Features:

- Includes an annual preventive maintenance and performance check at your convenience
- Unlimited in-home repairs; no shipping required
- Covers parts and labor on all manufacturer's defects, as well as wear and tear on parts
- Up to 5 years of coverage available

STANDARD SERVICE PLANS

Equipment Price	1-Year Plan	2-Year Plan	3-Year Plan
\$0.00 to \$300.00	\$29.99	\$39.99	\$59.99
\$301.00 to \$1000.00	\$89.99	\$119.99	\$149.99
\$1001.00 to \$2000.00	\$109.99	\$139.99	\$179.99
\$2001.00 to \$3000.00	\$179.99	\$209.99	\$239.99

Features:

- Unlimited in-home repairs; no shipping required
- Covers parts and labor on all manufacturer's defects, as well as wear and tear on parts
- Up to 3 years of coverage available

To protect your fitness equipment today, please
call Customer Care at **1-800-677-3838.**
Or, visit us online at **www.utserv.com.**



BEFORE YOU BEGIN

Thank you for selecting the new PROFORM® 135 CSX exercise bike. Cycling is an effective exercise for increasing cardiovascular fitness, building endurance, and toning the body. The 135 CSX exercise bike provides an impressive selection of features designed to make your workouts at home more effective and enjoyable.

For your benefit, read this manual carefully before you use the exercise bike. If you have questions after

reading this manual, please see the front cover of this manual. To help us assist you, note the product model number and serial number before contacting us. The model number and the location of the serial number decal are shown on the front cover of this manual.

Before reading further, please familiarize yourself with the parts that are labeled in the drawing below.

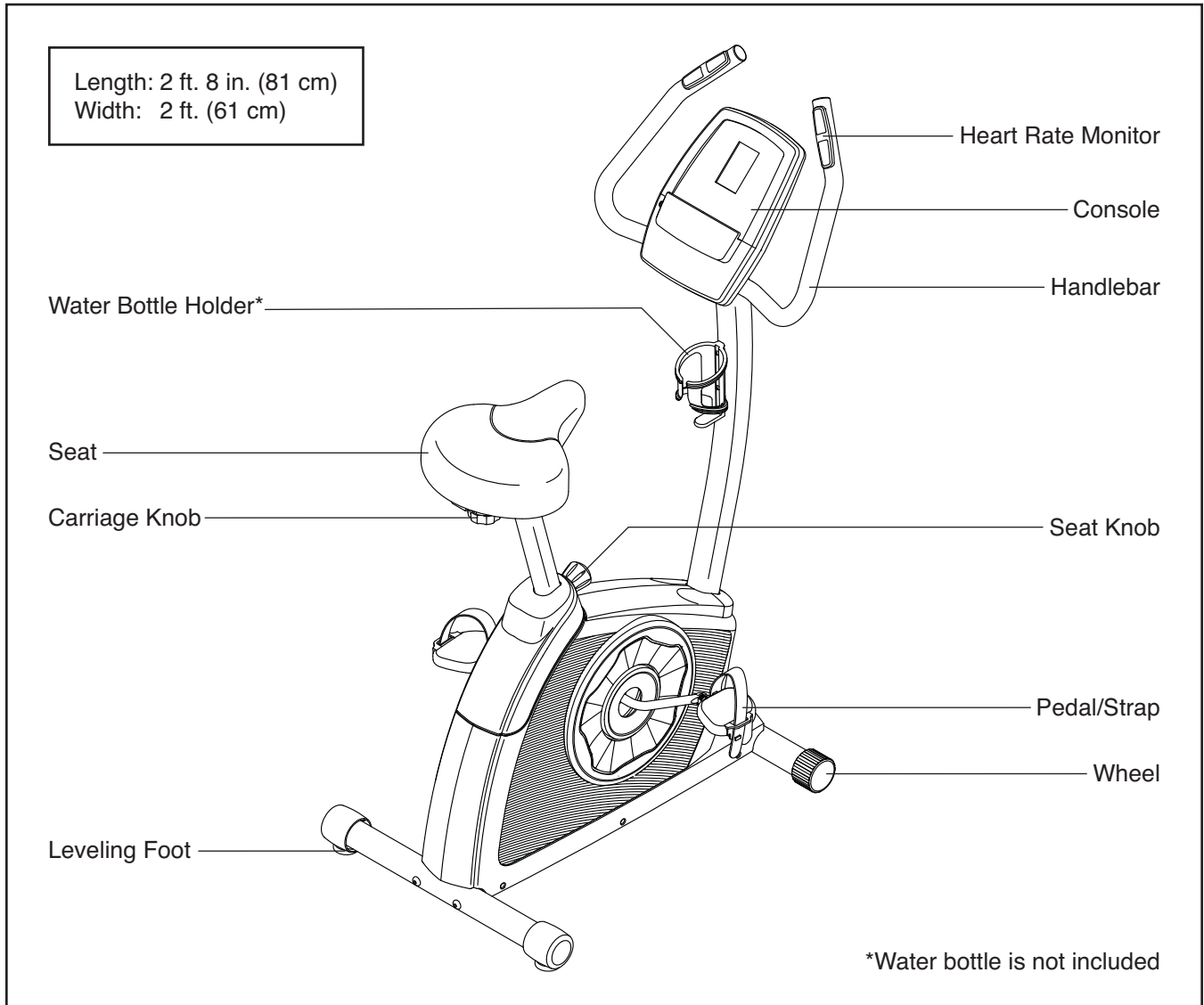

PART IDENTIFICATION CHART

Use the drawings below to identify the small parts needed for assembly. The number in parentheses below each drawing is the key number of the part, from the PART LIST near the end of this manual. The number following the key number is the quantity needed for assembly. **Note: If a part is not in the hardware kit, check to see if it has been preassembled. Extra parts may be included.**

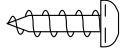

M4 x 12mm
Screw (57)-6

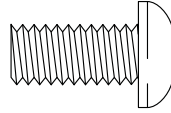

M8 x 18mm
Screw (42)-8

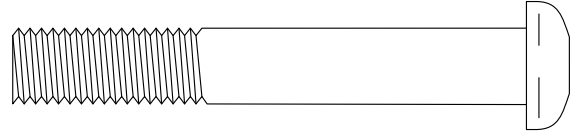

M10 x 68mm
Screw (44)-4

ASSEMBLY

- To hire an authorized service technician to assemble this product, call 1-800-445-2480.
- Assembly requires two persons.
- Place all parts in a cleared area and remove the packing materials. Do not dispose of the packing materials until you finish all assembly steps.
- Left parts are marked “L” or “Left” and right parts are marked “R” or “Right.”

- To identify small parts, see page 6.

In addition to the included tool(s), assembly requires the following tools:

one Phillips screwdriver 

one adjustable wrench 

Assembly may be easier if you have a set of wrenches. To avoid damaging parts, do not use power tools.

1. **Go to www.proformservice.com/registration on your computer and register your product.**

- activates your warranty
- saves you time if you ever need to contact Customer Care
- allows us to notify you of upgrades and offers

Note: If you do not have Internet access, call Customer Care (see the front cover of this manual) and register your product.

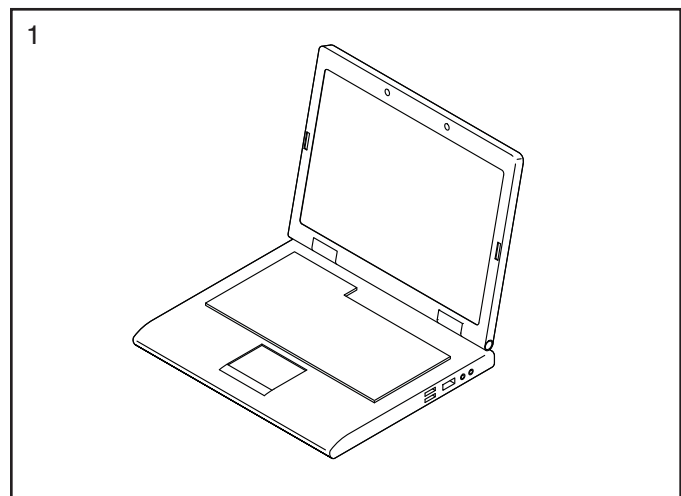

2. Identify the Rear Stabilizer (3), which has a Leveling Foot (28) near each end.

Set a sturdy piece of packing material (not shown) under the rear of the Frame (1).

Orient the Rear Stabilizer (3) as indicated by the sticker. Attach the Rear Stabilizer to the Frame (1) with two M10 x 68mm Screws (44).

Then, remove the packing material.

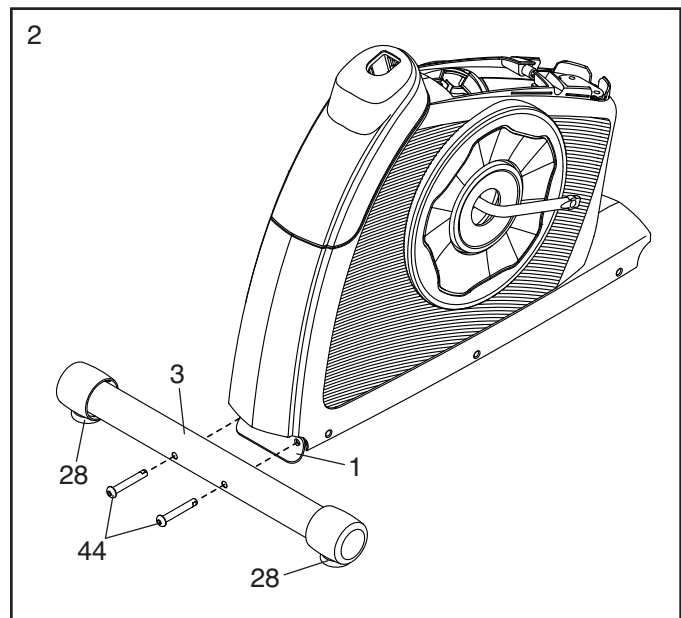

3. Set a sturdy piece of packing material under the front of the Frame (1).

Orient the Front Stabilizer (2) as indicated by the sticker. Attach the Front Stabilizer to the Frame (1) with two M10 x 68mm Screws (44).

Then, remove the packing material.

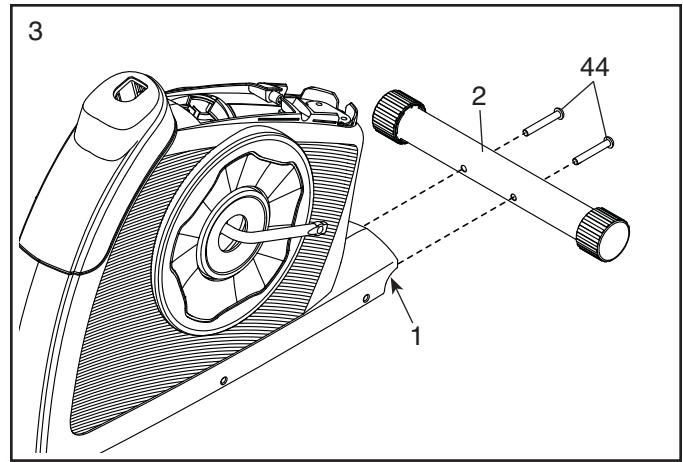

4. Orient the Upright (4) as shown.

Tip: Avoid pinching the Main Wire (41).

Attach the Upright (4) to the Frame (1) with four M8 x 18mm Screws (42); **start all the Screws, and then tighten them.**

Next, locate the wire tie in the Upright (4). Tie the lower end of the wire tie to the Main Wire (41). Then, pull the upper end of the wire tie until the Main Wire is routed through the Upright.

Tip: To prevent the Main Wire (41) from falling into the Upright (4), secure the Main Wire with the wire tie.

Insert the excess Main Wire (41) into the Upright (4).

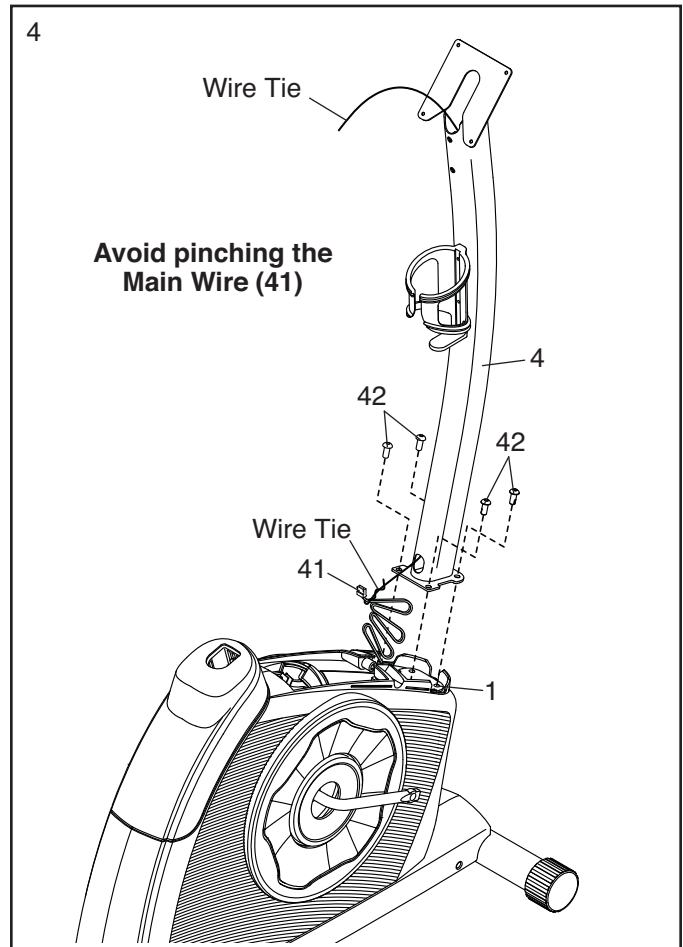

5. Orient the Rear and Front Upright Covers (19, 20) as shown.

Press the Rear and Front Upright Covers (19, 20) together around the Upright (4), and connect them with two M4 x 12mm Screws (57).

Then, press the Rear and Front Upright Covers (19, 20) downward onto the Left and Right Shields (21, 22).

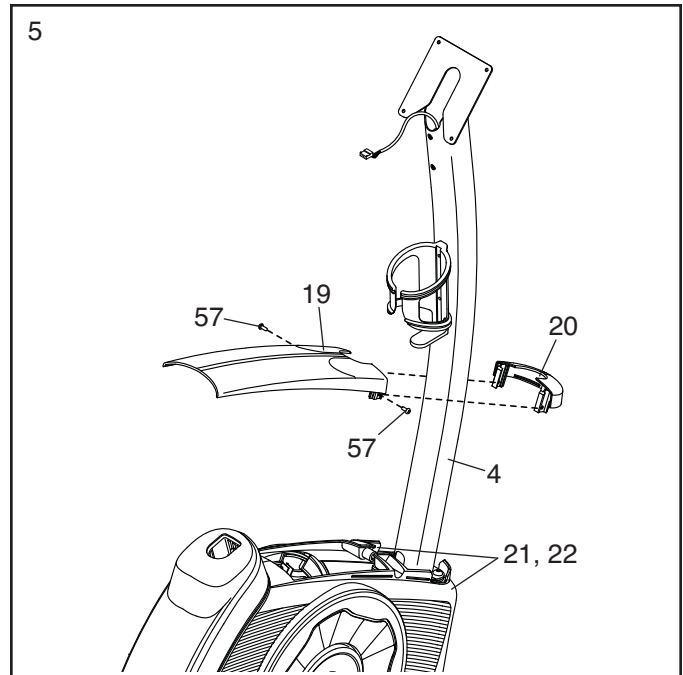

6. Orient the Handlebar (6) as shown.

Tip: Avoid pinching the Pulse Wire (58). Attach the Handlebar (6) to the Upright (4) with four M8 x 18mm Screws (42); **start all the Screws, and then tighten them.**

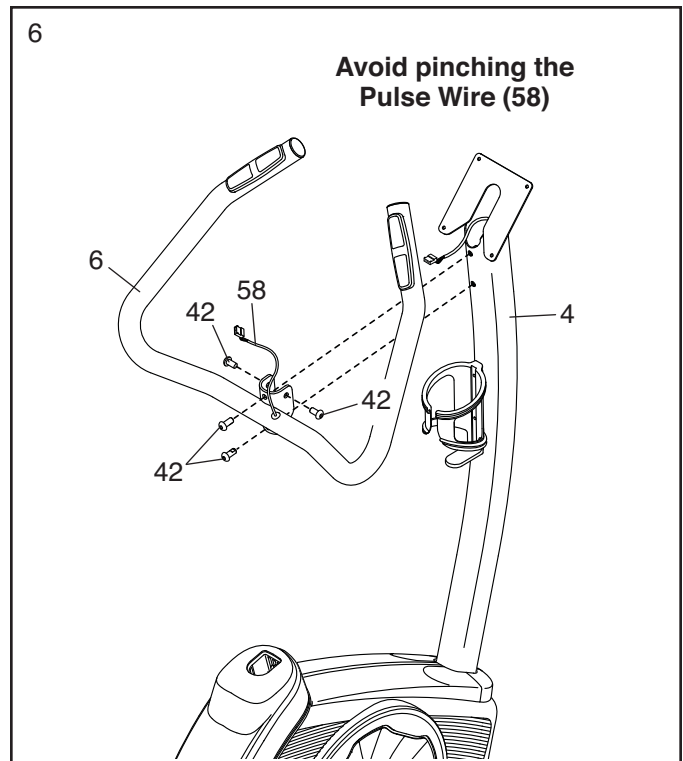

7. The Console (5) can use four D batteries (not included); alkaline batteries are recommended. Do not use old and new batteries together or alkaline, standard, and rechargeable batteries together. **IMPORTANT: If the Console has been exposed to cold temperatures, allow it to warm to room temperature before you insert batteries. Otherwise, you may damage the console displays or other electronic components.** Remove the screws and the battery covers, insert batteries into the battery compartments, and then reattach the battery covers. **Make sure to orient the batteries as shown by the diagrams inside the battery compartments.**

To purchase an optional power adapter, call the telephone number on the cover of this manual. To avoid damaging the console, use only a manufacturer-supplied regulated power adapter. Plug one end of the power adapter into the receptacle on the Console (5); plug the other end into an outlet installed in accordance with all local codes and ordinances.

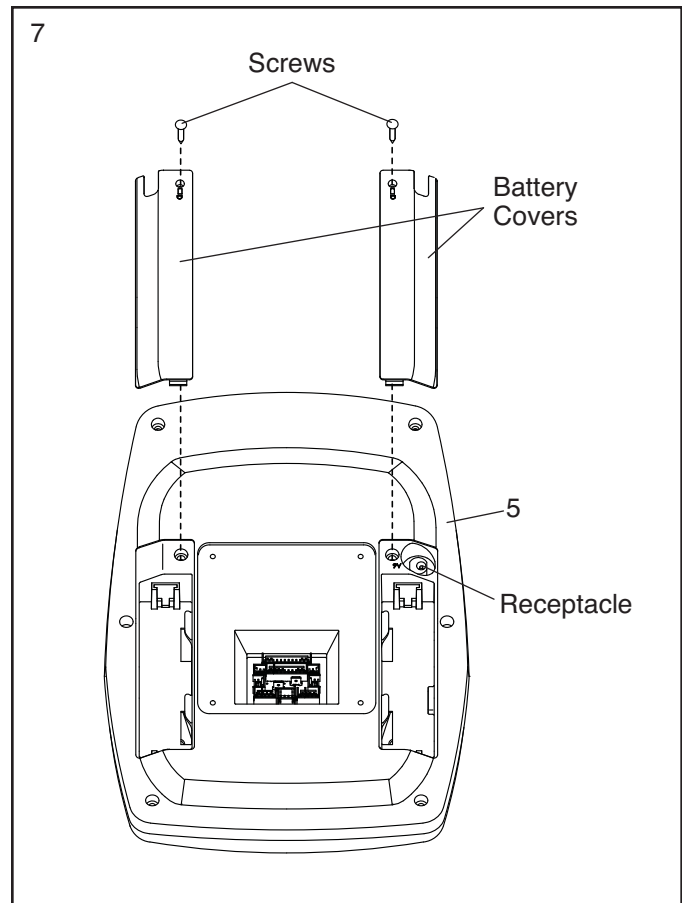

8. Untie and discard the wire tie on the Main Wire (41).

While a second person holds the Console (5) near the Upright (4), plug the Main Wire (41) and the Pulse Wire (58) into the receptacles on the Console.

The connectors on the Wires (41, 58) should slide easily into the receptacles and snap into place. If a connector does not slide easily into a receptacle, turn the connector and try again. **If you do not connect the connectors properly, the Console (5) may become damaged when you use the exercise bike.**

Insert the excess wire into the Upright (4).

Tip: Avoid pinching the wires. Attach the Console (5) to the Upright (4) with four M4 x 12mm Screws (57); **start all the Screws, and then tighten them.**

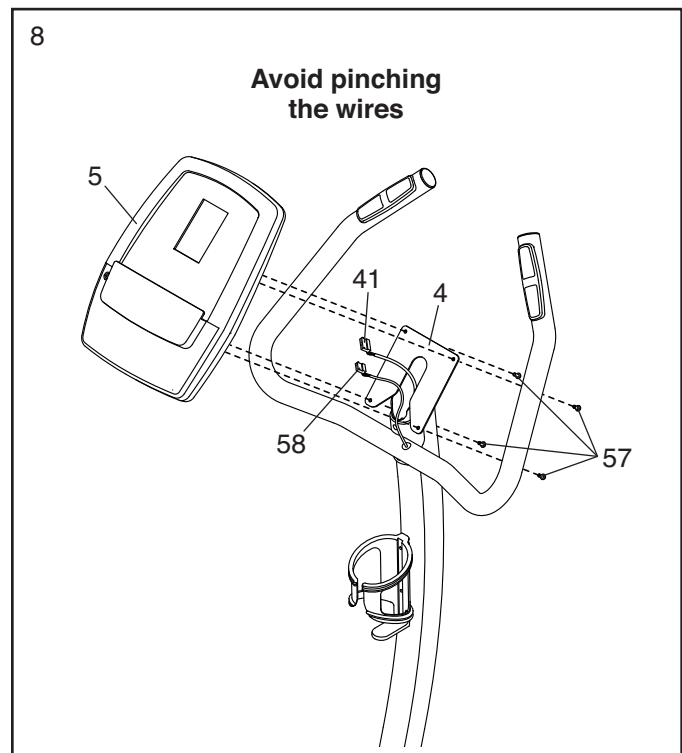

9. Orient the Seat Post (10) as shown. Loosen the Post Knob (18) a few turns, pull it outward, and insert the Seat Post into the Frame (1).

Then, slide the Seat Post (10) upward or downward to the desired position, and release the Post Knob (18) into one of the adjustment holes in the Seat Post. **Move the Seat Post upward or downward slightly to make sure that the Post Knob is engaged in one of the adjustment holes in the Seat Post.** Then, tighten the Post Knob.

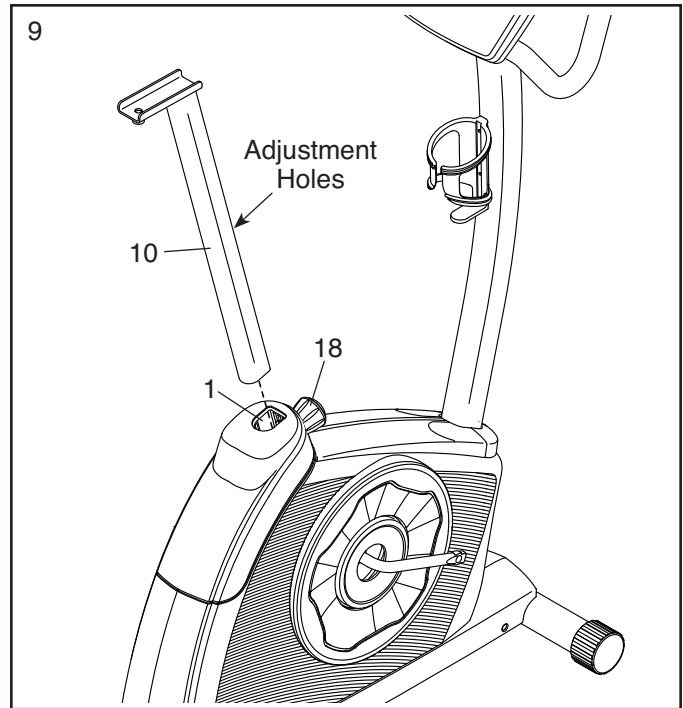

10. **See the inset drawing.** Remove the Carriage Knob (15) from the Seat Carriage (11).

Next, set the Seat Carriage (11) on the Seat Post (10) and hold it in place.

Insert the Carriage Knob (15) upward into the Seat Post (10), and tighten the Carriage Knob into the Carriage Bracket (14) inside the Seat Carriage (11). **Make sure that the Carriage Knob is tightened into the Carriage Bracket.**

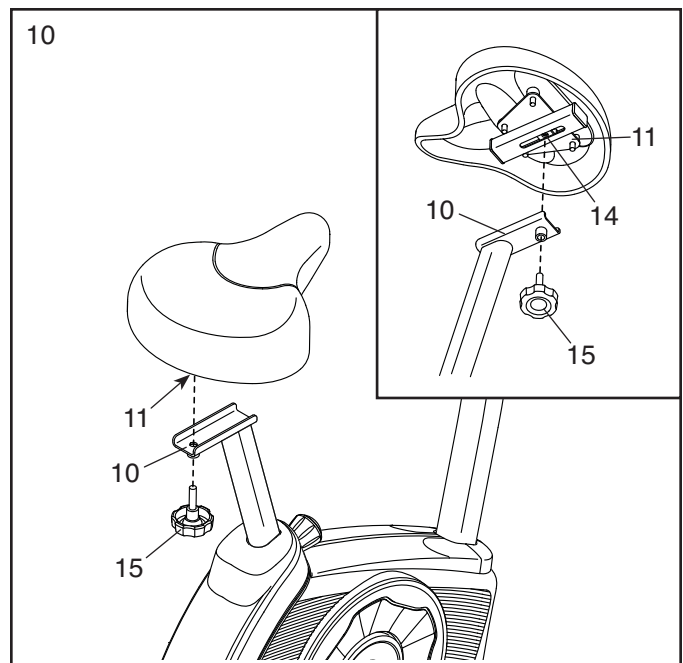

11. Identify the Right Pedal (29).

Using an adjustable wrench, **firmly tighten** the Right Pedal (29) **clockwise** into the right arm of the Crank (40).

Firmly tighten the Left Pedal (not shown) counterclockwise into the left arm of the Crank (not shown). IMPORTANT: You must turn the Left Pedal counterclockwise to attach it.

Adjust the strap on the Right Pedal (29) to the desired position, and press the end of the strap onto the tab on the Right Pedal. **Adjust the strap on the Left Pedal (not shown) in the same way.**

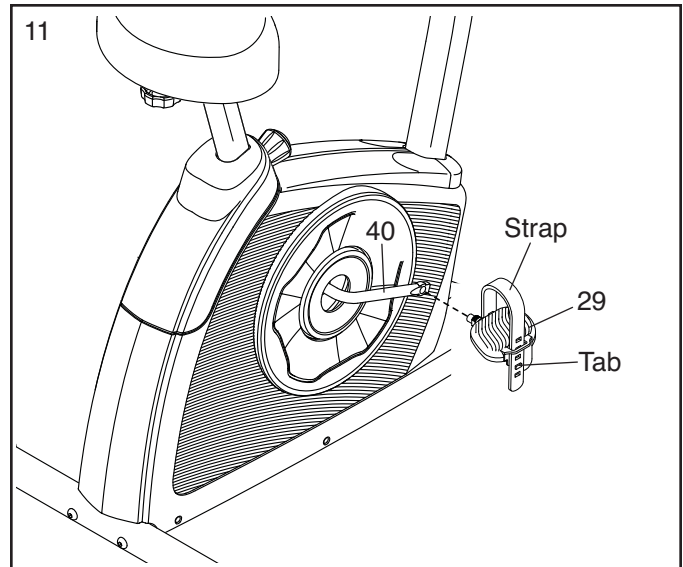

12. **After the exercise bike is assembled, inspect it to make sure that it is assembled correctly and that it functions properly. Make sure that all parts are properly tightened before you use the exercise bike.** Extra parts may be included. Place a mat beneath the exercise bike to protect the floor.

HOW TO USE THE EXERCISE BIKE

HOW TO ADJUST THE HEIGHT OF THE SEAT

For effective exercise, the seat should be at the proper height. As you pedal, there should be a slight bend in your knees when the pedals are in the lowest position.

To adjust the height of the seat, first loosen the post knob a few turns. Next, pull the post knob outward, slide the seat post upward or downward to the desired position, and then release the post knob into one of the adjustment holes in the seat post. **Move the seat post upward or downward slightly to make sure that the post knob is engaged in one of the adjustment holes in the seat post.** Then, tighten the post knob.

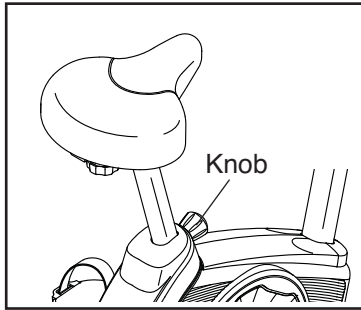

HOW TO ADJUST THE PEDAL STRAPS

To adjust the pedal straps, first pull the ends of the straps off the tabs on the pedals. Then, adjust the straps to the desired position, and press the ends of the straps onto the tabs.

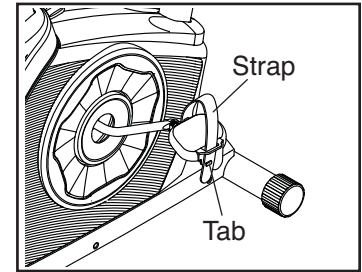

HOW TO LEVEL THE EXERCISE BIKE

If the exercise bike rocks slightly on your floor during use, turn one or both of the leveling feet under the rear stabilizer until the exercise bike is level.

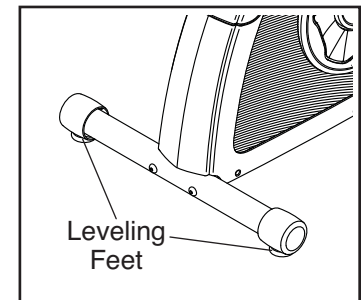

HOW TO ADJUST THE HORIZONTAL POSITION OF THE SEAT

To adjust the horizontal position of the seat, first loosen the carriage knob a few turns. Then, move the seat forward or backward to the desired position, and firmly tighten the carriage knob.

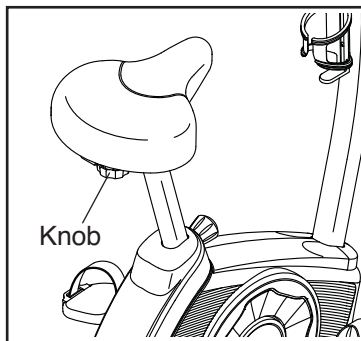

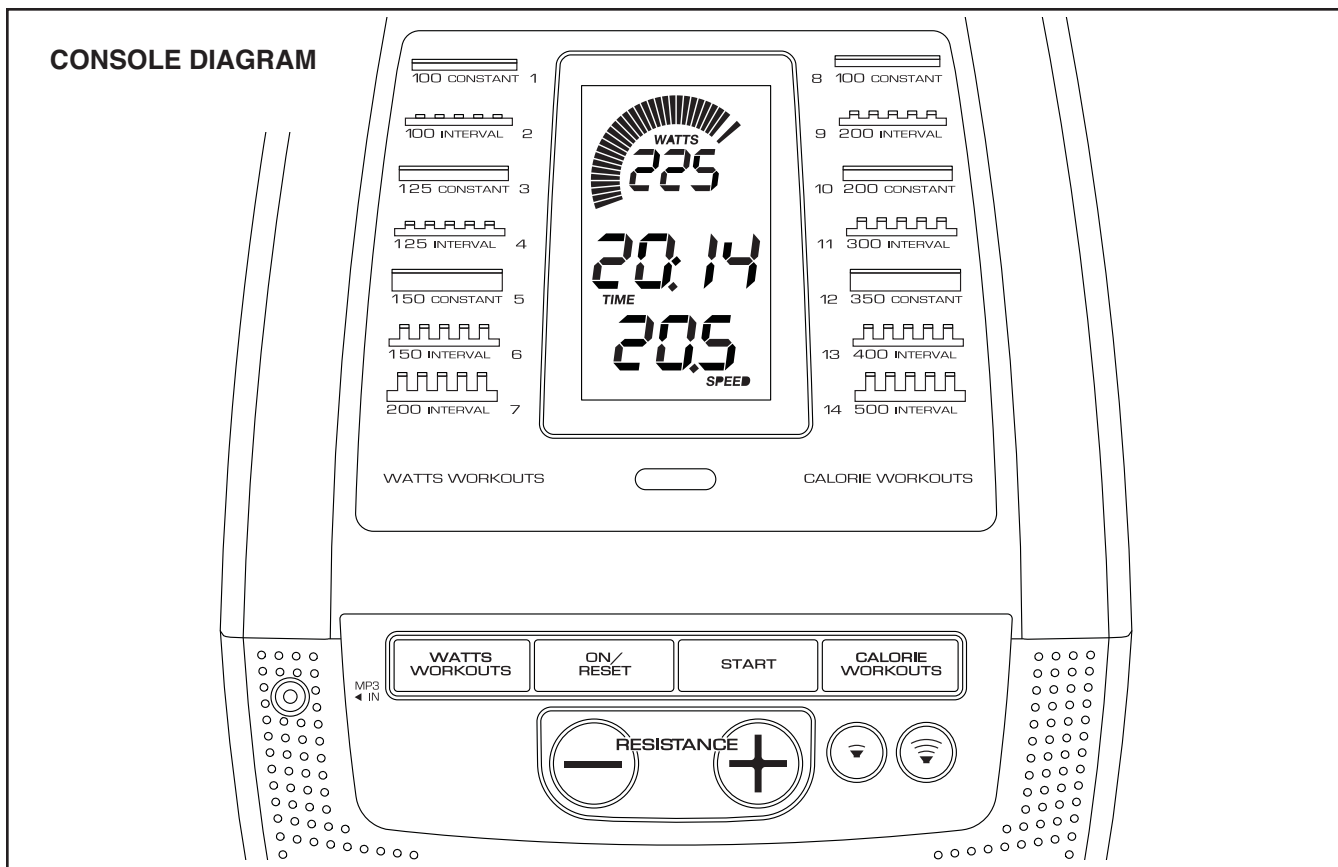

FEATURES OF THE CONSOLE

The advanced console offers an array of features designed to make your workouts more effective and enjoyable.

When you use the manual mode of the console, you can change the resistance of the pedals with the touch of a button. As you exercise, the console will provide continuous exercise feedback. You can even measure your heart rate using the handgrip heart rate monitor.

The console also offers a selection of preset workouts. Each preset workout automatically changes the resistance of the pedals and prompts you to maintain a target speed or a target watts output as it guides you through an effective workout.

You can even connect your MP3 player or CD player to the console sound system and listen to your favorite music or audio books while you exercise.

To use the manual mode, see page 15. **To use a preset workout**, see page 17. **To use the sound system**, see page 18. **To use the settings mode**, see page 18.

Note: Before using the console, make sure that batteries are installed (see assembly step 7 on page 10). If there is a sheet of plastic on the display, remove the plastic.

HOW TO USE THE MANUAL MODE

1. Turn on the console.

Press any button or begin pedaling to turn on the console.

When you turn on the console, the displays will turn on, a tone will sound, and the console will be ready for use.

2. Select the manual mode.

When you turn on the console, the manual mode will be selected automatically.

If you have selected a workout, reselect the manual mode by pressing the Watts Workouts or Calorie Workouts button repeatedly until zeros appear in the displays.

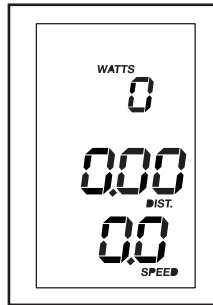

3. Begin pedaling and change the resistance of the pedals as desired.

As you pedal, change the resistance of the pedals by pressing the Resistance increase and decrease buttons.



Note: After you press the buttons, it will take a moment for the pedals to reach the selected resistance level.

4. Follow your progress with the displays.

The speed meter—This display will provide a visual representation of your pedaling speed. As you increase or decrease your pedaling speed, bars will appear or disappear in the speed meter.

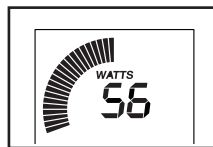

Note: During a preset workout, this display will show a target watts zone or a target speed zone for each segment of the workout.

The upper display—This display will show your pedaling speed in revolutions per minute (RPM) and your power output in watts. The display will change every few seconds.

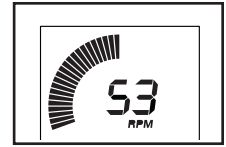

This display will also show the resistance level of the pedals for a few seconds each time the resistance level changes.

This display will also show your heart rate when you use the handgrip heart rate monitor (see step 5).

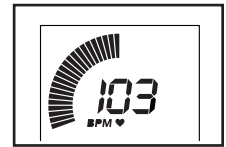

The center display—This display will show the distance (Dist.) you have pedaled in miles or kilometers and the elapsed time. The display will change every few seconds.

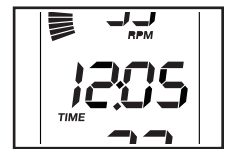

Note: During a preset workout, the display will show the time remaining in the workout instead of the elapsed time.

The lower display—This display will show your pedaling speed in miles per hour or kilometers per hour and the approximate number of calories (Cals.) you have burned. The display will change every few seconds.

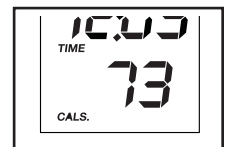

Change the volume level of the console by pressing the volume increase and decrease buttons.

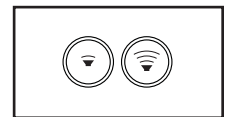

To reset the displays to zero, press the On/Reset button.

Note: The console can show pedaling speed and distance in either miles or kilometers. To change the unit of measurement, see THE SETTINGS MODE on page 18.

5. Measure your heart rate if desired.

If there are sheets of plastic on the metal contacts on the handgrip heart rate monitor, remove the plastic. In addition, make sure that your hands are clean. To measure your heart rate, hold the handgrip heart rate monitor with your palms resting against the contacts. **Avoid moving your hands or gripping the contacts tightly.**

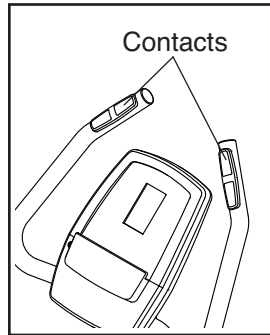

When your pulse is detected, a heart-shaped symbol will flash in the upper display and then your heart rate will be shown. **For the most accurate heart rate reading, hold the contacts for at least 15 seconds.**

If your heart rate is not shown, make sure that your hands are positioned as described. Be careful not to move your hands excessively or to squeeze the contacts tightly. For optimal performance, clean the contacts using a soft cloth; **never use alcohol, abrasives, or chemicals to clean the contacts.**

6. When you are finished exercising, the console will turn off automatically.

If the pedals do not move for several seconds, a series of tones will sound, the console will pause, and the time will flash in the display.

If the pedals do not move for several minutes, the console will turn off and the displays will be reset.

HOW TO USE A PRESET WORKOUT

1. Turn on the console.

Press any button or begin pedaling to turn on the console.

When you turn on the console, the displays will turn on, a tone will sound, and the console will be ready for use.

2. Select a preset workout.

To select a preset workout, press the Watts Workouts or Calorie Workouts button repeatedly until the number of the desired workout appears in the lower display.

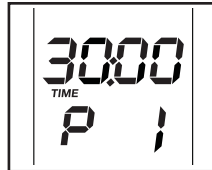

The duration of the workout will appear in the center display. Note: Profiles of the preset workouts are printed on the console.

3. Start the workout.

Press the Start button or begin pedaling to start the workout.

Each workout is divided into one-minute segments.

If you selected a watts workout, one resistance level and one watts target are programmed for each segment. Note: The same resistance level and/or watts target may be programmed for consecutive segments.

If you selected a calorie workout, one resistance level and one speed target are programmed for each segment. Note: The same resistance level and/or speed target may be programmed for consecutive segments.

At the end of each segment of the workout, a series of tones will sound. The resistance level for the next segment will appear in the upper display for a few seconds to alert you. The resistance of the pedals will then change.

The target zone will be shown in the target meter display. The space between the flashing bars represents the watts target or the speed target for the segment; the solid bars represent your actual watts output or your actual pedaling speed.

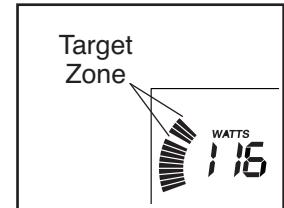

As you exercise, keep your watts output or your pedaling speed within the target zone for the current segment by increasing or decreasing your pedaling speed or by increasing or decreasing the resistance of the pedals.

IMPORTANT: The target is intended only to provide motivation. Make sure to pedal at a speed and a resistance level that is comfortable for you.

If the resistance level for the current segment is too high or too low, you can manually override the setting by pressing the Resistance buttons.

IMPORTANT: When the current segment of the workout ends, the pedals will automatically adjust to the resistance level programmed for the next segment.

If you stop pedaling for several seconds, a series of tones will sound and the workout will pause.

To restart the workout, simply resume pedaling. The workout will continue until the last segment of the workout ends.

4. Follow your progress with the displays.

See step 4 on page 15.

5. Measure your heart rate if desired.

See step 5 on page 16.

6. When you are finished exercising, the console will turn off automatically.

See step 6 on page 16.

HOW TO USE THE SOUND SYSTEM

To play music or audio books through the console sound system while you exercise, plug a 3.5 mm male to 3.5 mm male audio cable (not included) into the jack on the console and into a jack on your MP3 player, CD player, or other personal audio player; **make sure that the audio cable is fully plugged in.** **Note: To purchase an audio cable, see your local electronics store.**

Next, press the play button on your personal audio player. Adjust the volume level using the volume increase and decrease buttons on the console or the volume control on your personal audio player.

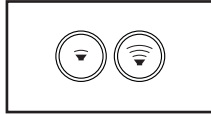

The console can show pedaling speed and distance in either miles or kilometers. The lower display will show the selected unit of measurement. An E for English miles or an M for metric kilometers will appear in the display. To change the unit of measurement, press the Resistance increase button repeatedly.

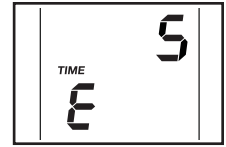

Note: When you replace the batteries, it may be necessary to reselect the unit of measurement.

The center display will show the total distance (in miles or kilometers) that the exercise bike has been pedaled and the total time (in hours) that the console has been used since the exercise bike was purchased. Press the Calorie Workouts button repeatedly to view the total distance and the total time.

To exit the settings mode, press the Watts Workouts button.

THE SETTINGS MODE

The console features a settings mode that allows you to select a unit of measurement for the console and to view console usage information.

To select the settings mode, press and hold down the Watts Workouts button until the settings mode information appears in the display.

FCC INFORMATION

This equipment has been tested and found to comply with the limits for a Class B digital device, pursuant to part 15 of the FCC Rules. These limits are designed to provide reasonable protection against harmful interference in a residential installation. This equipment generates, uses, and can radiate radio frequency energy and, if not installed and used in accordance with the instructions, may cause harmful interference to radio communications. However, there is no guarantee that interference will not occur in a particular installation. If this equipment does cause harmful interference to radio or television reception, which can be determined by turning the equipment off and on, try to correct the interference by one or more of the following measures:

- Reorient or relocate the receiving antenna.
- Increase the separation between the equipment and the receiver.
- Connect the equipment into an outlet on a circuit different from that to which the receiver is connected.
- Consult the dealer or an experienced radio/TV technician for help.

FCC CAUTION: To assure continued compliance, use only shielded interface cables when connecting to computer or peripheral devices. Changes or modifications not expressly approved by the party responsible for compliance could void the user's authority to operate this equipment.

MAINTENANCE AND TROUBLESHOOTING

MAINTENANCE

Regular maintenance is important for optimal performance and to reduce wear. Inspect and properly tighten all parts each time the exercise bike is used. Replace any worn parts immediately.

To clean the exercise bike, use a damp cloth and a small amount of mild soap. **IMPORTANT: To avoid damage to the console, keep liquids away from the console and keep the console out of direct sunlight.**

CONSOLE TROUBLESHOOTING

Most console problems are the result of low batteries. See assembly step 7 on page 10 for battery replacement instructions.

If the console does not display your heart rate when you use the handgrip heart rate monitor, see step 5 on page 16.

HOW TO ADJUST THE REED SWITCH

If the console does not display correct feedback, the reed switch should be adjusted.

To adjust the reed switch, you must remove the rear and front upright covers as described below.

See assembly step 5 on page 9. Using a standard screwdriver, release the tabs along the bottom edges of the Rear and Front Upright Covers (19, 20), remove the two M4 x 12mm Screws (57), and then remove the Rear and Front Upright Covers.

Locate the Reed Switch (35). Turn the Crank (40) until a Magnet (39) is aligned with the Reed Switch. Loosen, but do not remove, the two indicated M4 x 16mm Flange Screws (36). Slide the Reed Switch slightly closer to or away from the Magnet, and then retighten the Flange Screws.

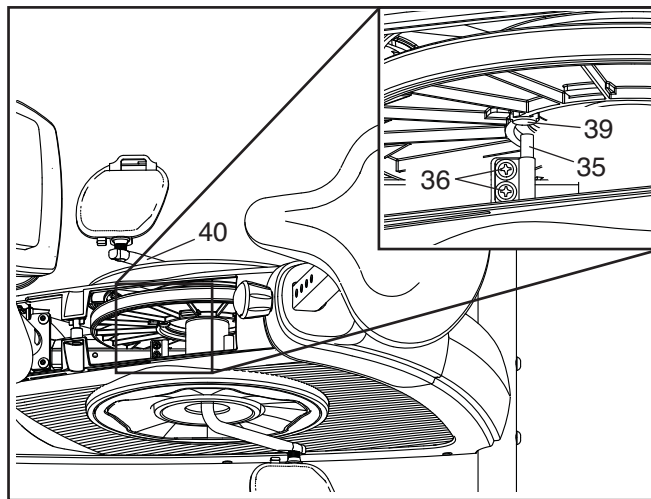

Turn the Crank (40) so that the Magnet (39) passes the Reed Switch (35) repeatedly. Repeat these actions until the console displays correct feedback.

When the reed switch is correctly adjusted, reattach the rear and front upright covers.

HOW TO ADJUST THE DRIVE BELT

If the pedals slip while you are pedaling, even while the resistance is adjusted to the highest level, the drive belt may need to be adjusted.

To adjust the drive belt, you must remove the parts described below.

Loosen the Post Knob (18) a few turns, pull it outward, and remove the Seat Post (10). Then, using an adjustable wrench, remove the Post Knob.

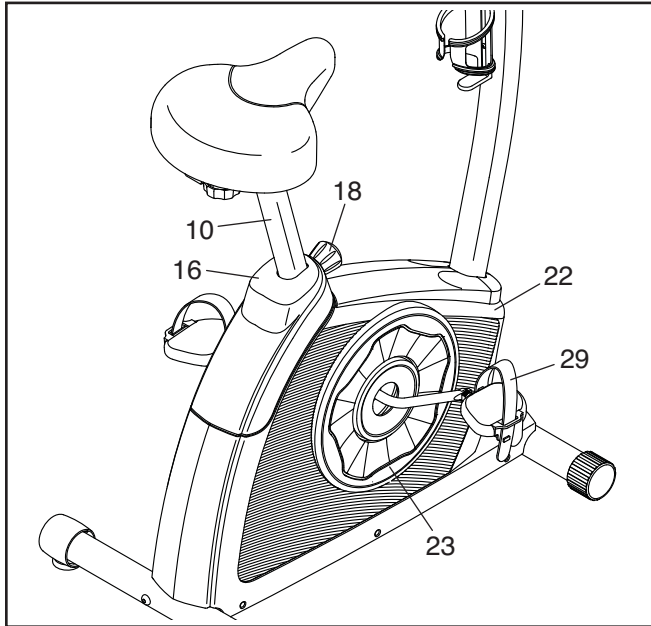

Using a standard screwdriver, release the tabs along the bottom edge of the Post Cover (16) and remove it. Then, using an adjustable wrench, turn the Right Pedal (29) counterclockwise and remove it.

Using a standard screwdriver, release the tabs around the edge of the right Lock Ring (23), and then remove it from the Right Shield (22).

See the **EXPLODED DRAWING** on page 23.

Identify the Left and Right Shields (21, 22). Remove all of the screws from the Left and Right Shields; **there are two sizes of screws in the shields—note which size of screw you remove from each hole.** Then, gently remove the Right Shield.

Next, loosen the Adjustment Screw (47). Then, tighten the Idler Screw (45) until the Drive Belt (59) is tight.

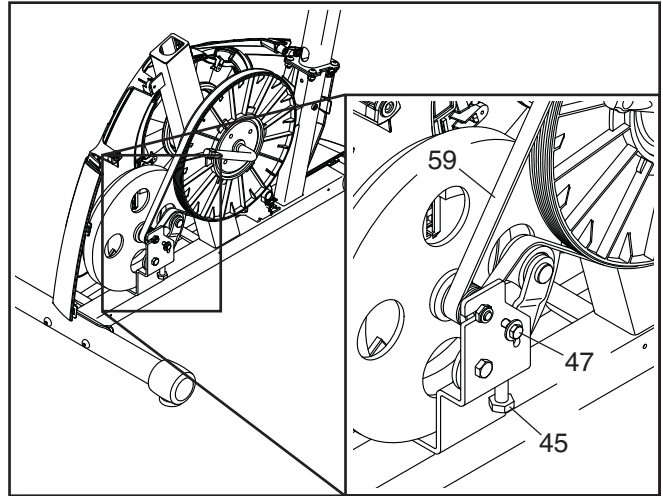

When the Drive Belt (59) is tight, tighten the Adjustment Screw (47).

Then, reattach the left and right shields, the right lock ring, the right pedal, the post cover, the post knob, and the seat post.

EXERCISE GUIDELINES

⚠️ WARNING: Before beginning this or any exercise program, consult your physician. This is especially important for persons over age 35 or persons with pre-existing health problems.

The heart rate monitor is not a medical device. Various factors may affect the accuracy of heart rate readings. The heart rate monitor is intended only as an exercise aid in determining heart rate trends in general.

These guidelines will help you to plan your exercise program. For detailed exercise information, obtain a reputable book or consult your physician. Remember, proper nutrition and adequate rest are essential for successful results.

EXERCISE INTENSITY

Whether your goal is to burn fat or to strengthen your cardiovascular system, exercising at the proper intensity is the key to achieving results. You can use your heart rate as a guide to find the proper intensity level. The chart below shows recommended heart rates for fat burning and aerobic exercise.

165	155	145	140	130	125	115	♥
145	138	130	125	118	110	103	♥
125	120	115	110	105	95	90	♥
<hr/>							
20	30	40	50	60	70	80	

To find the proper intensity level, find your age at the bottom of the chart (ages are rounded off to the nearest ten years). The three numbers listed above your age define your “training zone.” The lowest number is the heart rate for fat burning, the middle number is the heart rate for maximum fat burning, and the highest number is the heart rate for aerobic exercise.

Burning Fat—To burn fat effectively, you must exercise at a low intensity level for a sustained period of time. During the first few minutes of exercise, your body uses carbohydrate calories for energy. Only after the first few minutes of exercise does your body begin to use stored fat calories for energy. If your goal is to burn fat, adjust the intensity of your exercise until your heart rate is near the lowest number in your training zone. For maximum fat burning, exercise with your heart rate near the middle number in your training zone.

Aerobic Exercise—If your goal is to strengthen your cardiovascular system, you must perform aerobic exercise, which is activity that requires large amounts of oxygen for prolonged periods of time. For aerobic exercise, adjust the intensity of your exercise until your heart rate is near the highest number in your training zone.

WORKOUT GUIDELINES

Warming Up—Start with 5 to 10 minutes of stretching and light exercise. A warm-up increases your body temperature, heart rate, and circulation in preparation for exercise.

Training Zone Exercise—Exercise for 20 to 30 minutes with your heart rate in your training zone. (During the first few weeks of your exercise program, do not keep your heart rate in your training zone for longer than 20 minutes.) Breathe regularly and deeply as you exercise; never hold your breath.

Cooling Down—Finish with 5 to 10 minutes of stretching. Stretching increases the flexibility of your muscles and helps to prevent post-exercise problems.

EXERCISE FREQUENCY

To maintain or improve your condition, complete three workouts each week, with at least one day of rest between workouts. After a few months of regular exercise, you may complete up to five workouts each week, if desired. Remember, the key to success is to make exercise a regular and enjoyable part of your everyday life.

PART LIST

Model No. PFEX51915.0 R1215A

Key No.	Qty.	Description	Key No.	Qty.	Description
1	1	Frame	32	1	Idler
2	1	Front Stabilizer	33	1	Resistance Motor
3	1	Rear Stabilizer	34	1	Resistance Cable
4	1	Upright	35	1	Reed Switch/Wire
5	1	Console	36	2	M4 x 16mm Flange Screw
6	1	Handlebar	37	1	Clamp
7	2	Pulse Sensor	38	1	Crank Bearing Assembly
8	2	Handlebar Cap	39	2	Magnet
9	1	Water Bottle Holder	40	1	Crank/Pulley
10	1	Seat Post	41	1	Main Wire
11	1	Seat Carriage	42	8	M8 x 18mm Screw
12	1	Seat	43	2	Clip
13	2	Carriage Cap	44	4	M10 x 68mm Screw
14	1	Carriage Bracket	45	1	Idler Screw
15	1	Carriage Knob	46	1	Pivot Screw
16	1	Post Cover	47	1	Adjustment Screw
17	1	Post Sleeve	48	1	M6 Washer
18	1	Post Knob	49	1	Snap Ring
19	1	Rear Upright Cover	50	2	M8 Thin Locknut
20	1	Front Upright Cover	51	4	M8 Locknut
21	1	Left Shield	52	7	M4 x 16mm Self-tapping Screw
22	1	Right Shield	53	16	M3 x 8mm Screw
23	2	Lock Ring	54	2	M4 x 20mm Screw
24	2	Shield Cover	55	4	Resistance Motor Screw
25	2	Crank Cover	56	2	M4 x 19mm Screw
26	2	Rear Stabilizer Cap	57	6	M4 x 12mm Screw
27	2	Wheel Cap	58	1	Pulse Wire
28	2	Leveling Foot	59	1	Drive Belt
29	1	Right Pedal/Strap	*	—	User's Manual
30	1	Left Pedal/Strap	*	—	Assembly Tool
31	1	Eddy Mechanism			

Note: Specifications are subject to change without notice. For information about ordering replacement parts, see the back cover of this manual. *These parts are not illustrated.

EXPLODED DRAWING

Model No. PFEX51915.0 R1215A

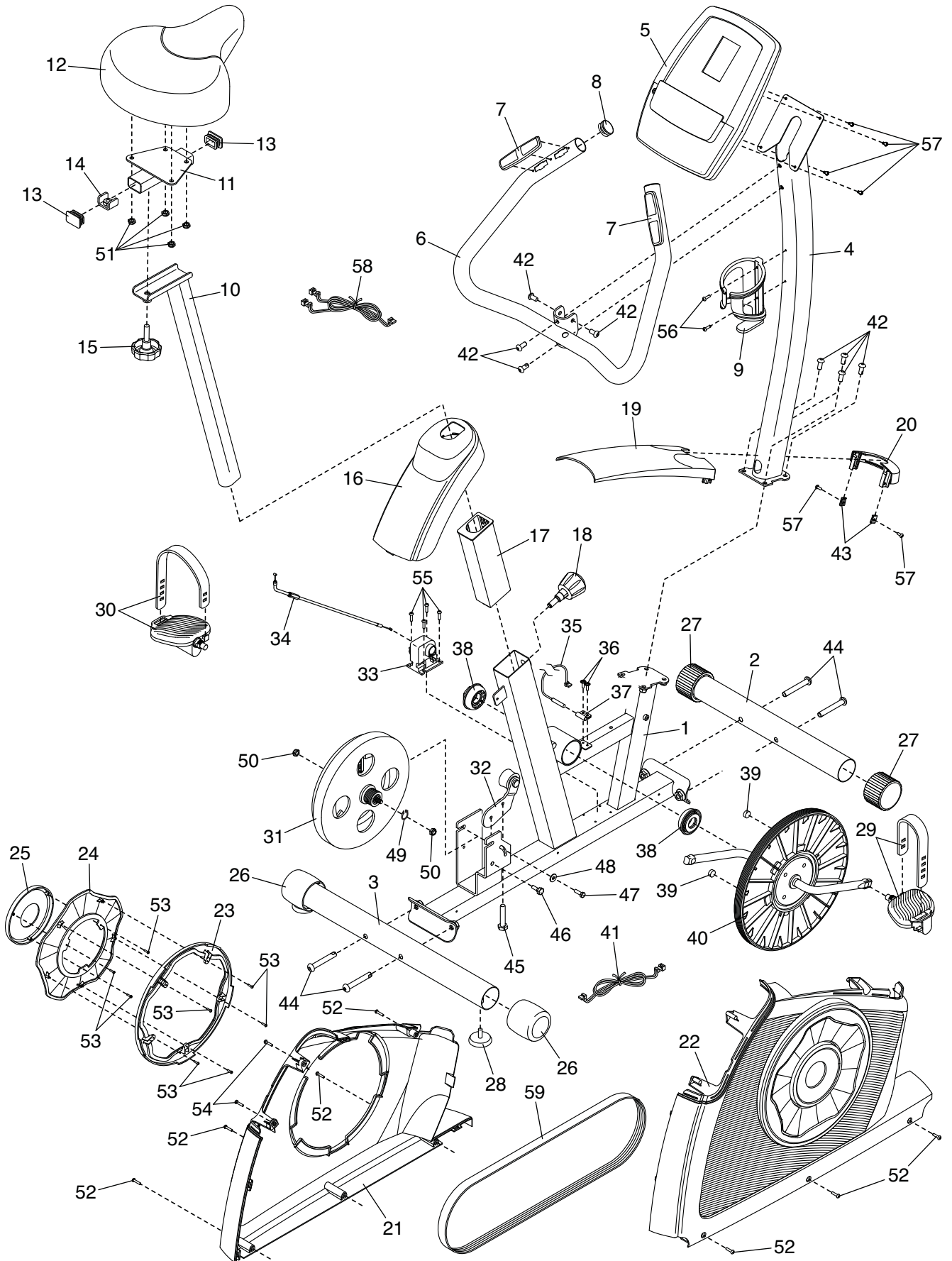

ORDERING REPLACEMENT PARTS

To order replacement parts, please see the front cover of this manual. To help us assist you, be prepared to provide the following information when contacting us:

- the model number and serial number of the product (see the front cover of this manual)
- the name of the product (see the front cover of this manual)
- the key number and description of the replacement part(s) (see the PART LIST and the EXPLODED DRAWING near the end of this manual)

LIMITED WARRANTY

IMPORTANT: To protect your fitness equipment with an extended service plan, see page 4.

ICON Health & Fitness, Inc. (ICON) warrants this product to be free from defects in workmanship and material, under normal use and service conditions. The frame is warranted for five (5) years from the date of purchase. Parts and labor are warranted for ninety (90) days from the date of purchase.

This warranty extends only to the original purchaser (customer). ICON's obligation under this warranty is limited to repairing or replacing, at ICON's option, the product through one of its authorized service centers. All repairs for which warranty claims are made must be preauthorized by ICON. If the product is shipped to a service center, freight charges to and from the service center will be the customer's responsibility. If replacement parts are shipped while the product is under warranty, the customer will be responsible for a minimal handling charge. For in-home service, the customer will be responsible for a minimal trip charge. This warranty does not extend to freight damage to the product. This warranty will automatically be voided if the product is used as a store display model, if the product is purchased or transported outside the USA, if all instructions in this manual are not followed, if the product is abused or improperly or abnormally used, or if the product is used for commercial or rental purposes. No other warranty beyond that specifically set forth above is authorized by ICON.

ICON is not responsible or liable for indirect, special, or consequential damages arising out of or in connection with the use or performance of the product; damages with respect to any economic loss, loss of property, loss of revenues or profits, loss of enjoyment or use, or costs of removal or installation; or other consequential damages of any kind. Some states do not allow the exclusion or limitation of incidental or consequential damages. Accordingly, the above limitation may not apply to the customer.

The warranty extended hereunder is in lieu of any and all other warranties, and any implied warranties of merchantability or fitness for a particular purpose are limited in their scope and duration to the terms set forth herein. Some states do not allow limitations on how long an implied warranty lasts. Accordingly, the above limitation may not apply to the customer.

This warranty provides specific legal rights; the customer may have other rights that vary from state to state.

ICON Health & Fitness, Inc., 1500 S. 1000 W., Logan, UT 84321-9813