

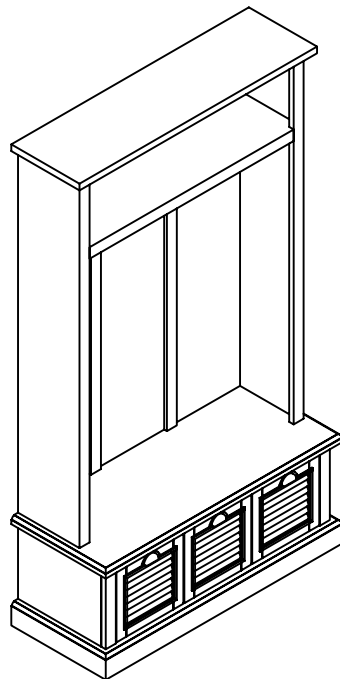
# HOME DECORATORS COLLECTION

SK17013 VENICIA LOCKER STORAGE 74"Hx42"Wx16.75"D

INV#11573

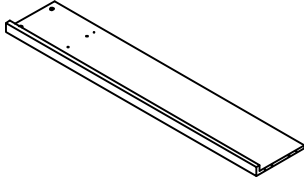
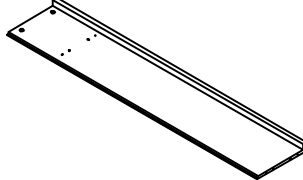
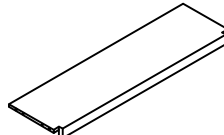
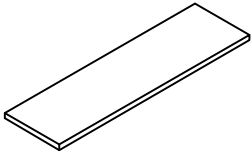
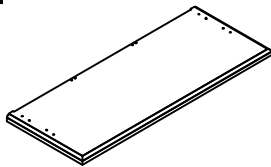
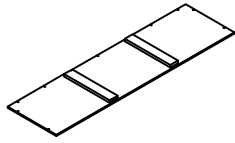
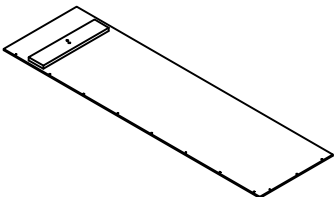
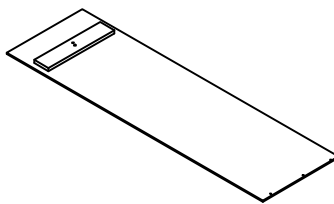
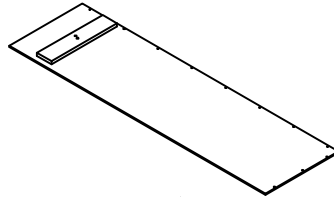
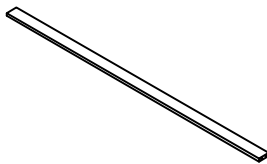
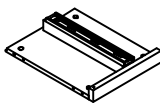
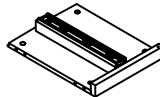
## ASSEMBLY INSTRUCTIONS

Made In China

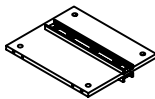


Thank you for purchasing this quality product. Be sure to check all packing material carefully for small parts, which may have come loose inside the carton during shipment. Count all parts and material hardware, then compare with parts list to be sure all parts are present. If any parts are missing or damaged, phone, fax, or mail to our Customer Service Department for efficient and speedy service. Please indicate the model number and code letter of part(s) needed.

**IMPORTANT NOTE:** Follow instructions listed below in proper sequence as numbered to assure fast, easy and correct assembly.

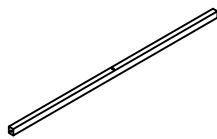
<b>PARTS LIST</b>		
<b>A</b> 	<b>B</b> 	<b>C</b> 
UPPER LEFT SIDE PANEL-1PC	UPPER RIGHT SIDE PANEL-1PC	FIXED SHELF-1PC
<b>D</b> 	<b>E</b> 	<b>F</b> 
TOP PANEL-1PC	FIXED PANEL-1PC	UPPER BACK PANEL-1PC
<b>G</b> 	<b>H</b> 	<b>I</b> 
LEFT BACK PANEL-1PC	CENTER BACK PANEL-1PC	RIGHT BACK PANEL-1PC
<b>J</b> 	<b>K</b> 	<b>L</b> 
BACK SUPPORT SLAT -2PCS	LOWER LEFT SIDE PANEL-1PC	LOWER RIGHT SIDE PANEL-1PC

M



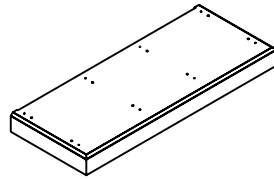
DIVIDER-2PCS

N



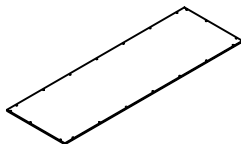
FRONT CROSS BAR-1PC

O



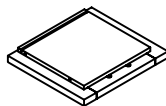
BOTTOM PANEL-1PC

P



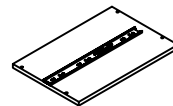
LOWER BACK PANEL-1PC

Q



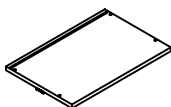
DRAWER  
FRONT PANEL-3PCS

R



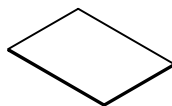
DRAWER  
LEFT SIDE PANEL-3PCS

S



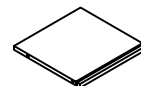
DRAWER RIGHT  
SIDE PANEL-3PCS

T



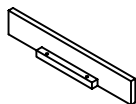
DRAWER  
BOTTOM PANEL-3PCS

U




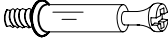





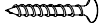





DRAWER BACK PANEL-3PCS

V



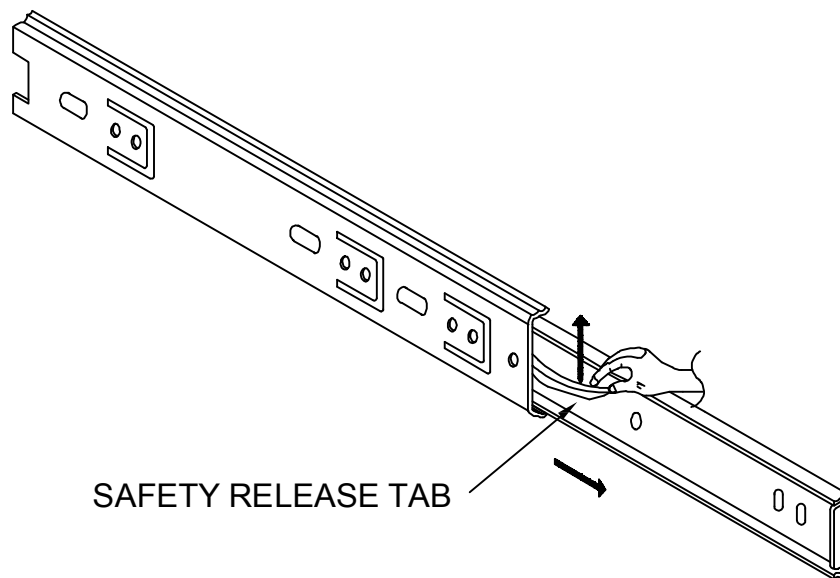
SUPPORT PANEL-2PCS

NOTE:THE SURFACE WITH THE STICKER IS THE BACK SIDE

<p><b>a</b></p>  <p>WOOD DOWEL-42PCS</p>	<p><b>b</b></p>  <p>CAM LOCK BOLT-24PCS</p>	<p><b>c</b></p>  <p>CAM LOCK-24PCS</p>
<p><b>d</b></p>  <p>5/8"L ROUND HEAD SCREW-76PCS</p>	<p><b>e</b></p>  <p>1"L FLAT HEAD SCREW-29PC</p>	<p><b>f</b></p>  <p>HALF ROUND HANDLE-3PCS</p>
<p><b>g</b></p>  <p>HANDLE BOLT-6PCS</p>	<p><b>h</b></p>  <p>1-1/2" FLAT HEAD SCREW-4PCS</p>	<p><b>k</b></p>  <p>LONG PLASTIC COVER-4PCS</p>
<p><b>j</b></p>  <p>METAL PLATE-20PCS</p>	<p><b>l</b></p>  <p>DOUBLE HOOK-3PCS</p>	<p><b>m</b></p>  <p>1/2"L FLAT HEAD SCREW-6PCS</p>
<p><b>n</b></p>  <p>SHORT PLASTIC COVER-4PCS</p>		

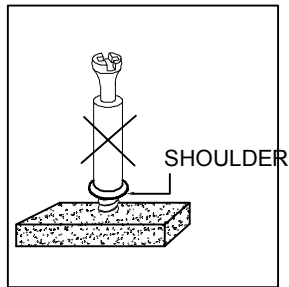
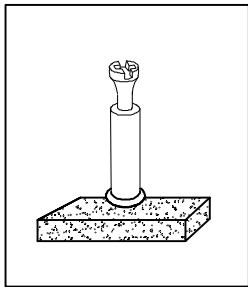
NOTE:THE SURFACE WITH THE STICKER IS THE BACK SIDE

## HOW TO SEPARATE GLIDES



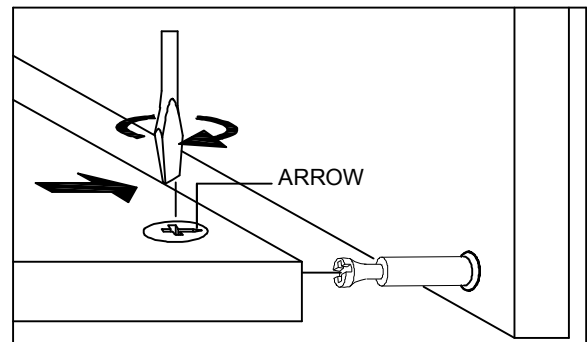
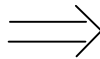
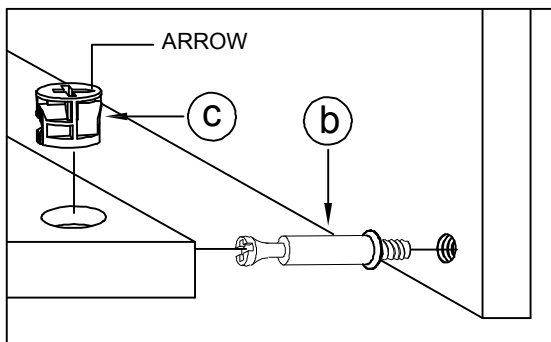
PRIOR TO ASSEMBLY, WE SUGGEST SEPARATING THE INNER GLIDES FROM THE OUTER-GLIDES, SIMPLY PULL THE LEFT/RIGHT INNER GLIDES FROM THE OUTER GLIDES EXPOSING A SMALL BLACK SAFETY RELEASE TAB, BY PUSHING THE SAFETY RELEASE TAB. YOU WILL BE ABLE TO SEPARATE THE GLIDES.

NOTE: • UPON OPENING, THOROUGHLY CLEAN ALL WOOD SURFACES TO REMOVE DUST AND DIRT THAT MAY HAVE SETTLED ONTO THE FINISH DURING SHIPMENT. IN ORDER TO PREVENT DAMAGE DURING ASSEMBLY. PLEASE ASSEMBLE THIS ITEM WITH AT LEAST TWO PEOPLE.



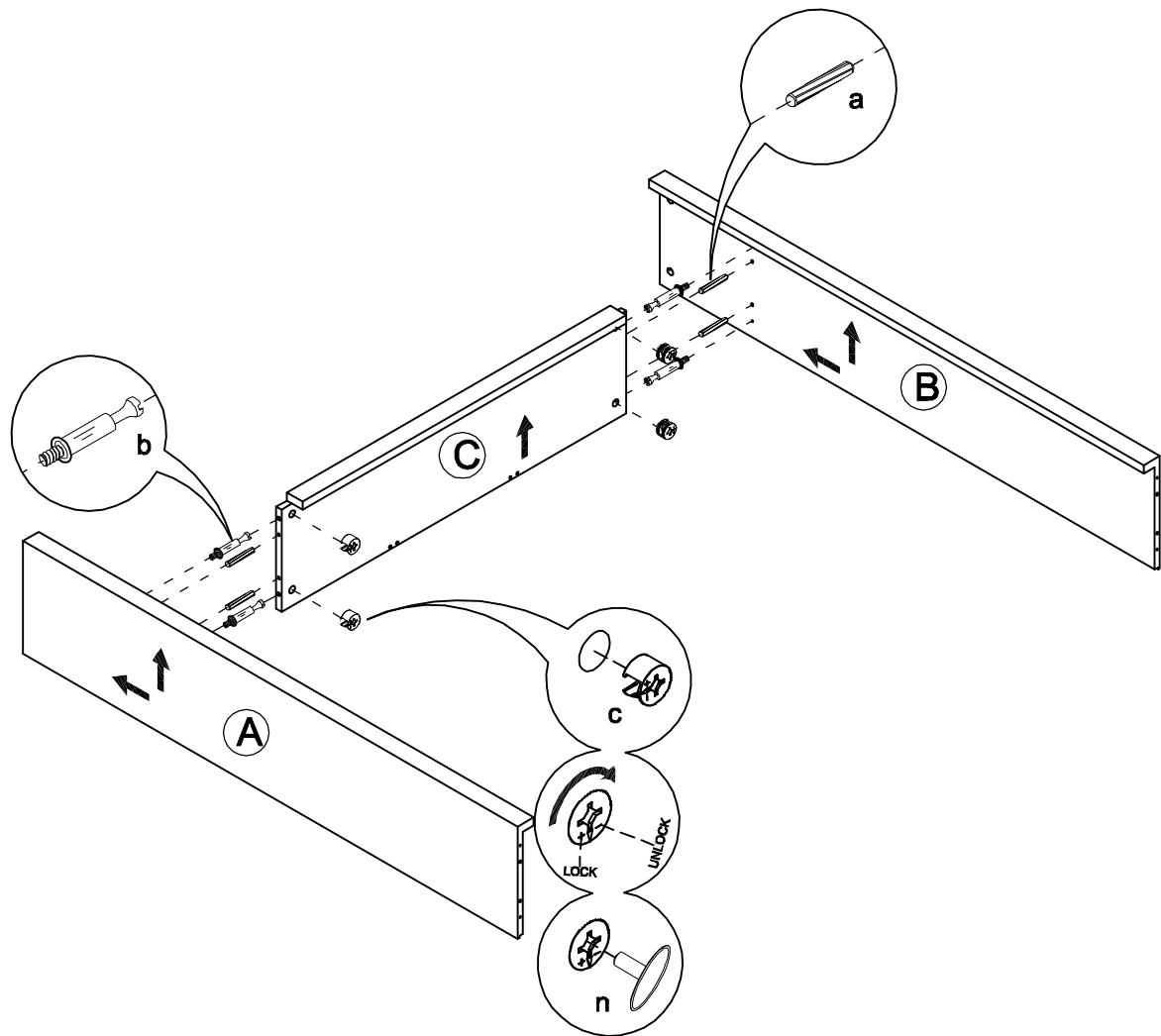
NOTE: TURN THE CAM-BOLT SCREWS UNTIL THEY ARE TIGHT, THE SHOULDER SHOULD BE AGAINST THE SURFACE OF THE PART.

## HOW TO USE THE CAM-TOOL



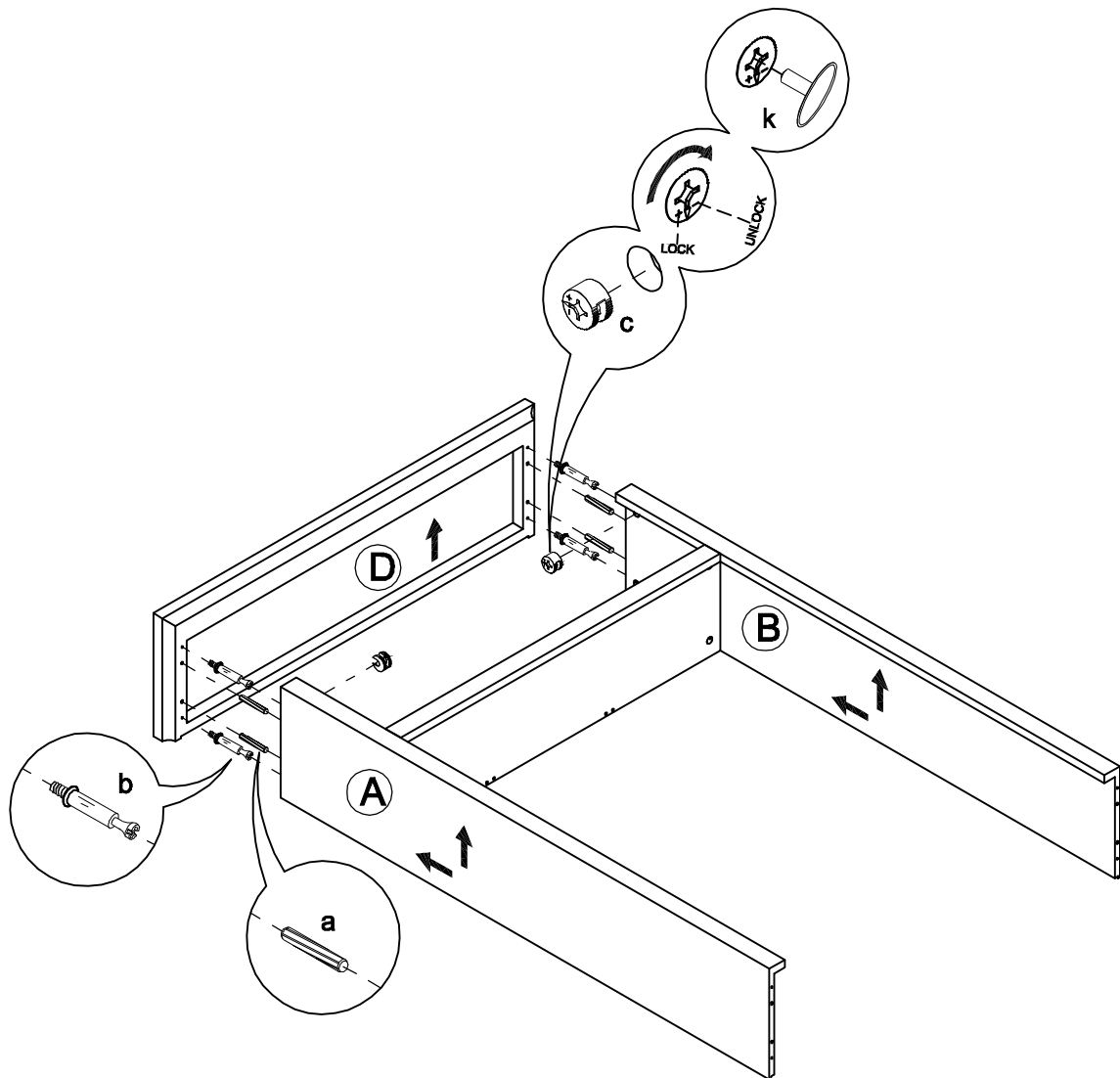
NOTE: • THE ARROWS ON THE HIDDEN CAM-LOCKS SHOULD POINT TO THE CAM-BOLTS.

# FIG 1



- INSTALL THE WOOD DOWEL (a) AND THE CAM LOCK BOLT (b) IN TO THE UPPER LEFT SIDE PANEL (A) AND THE UPPER RIGHT SIDE PANEL (B).
- JOIN THE UPPER LEFT SIDE PANEL (A) AND THE UPPER RIGHT SIDE PANEL (B) TO THE FIXED SHELF (C) BY USING THE WOOD DOWEL (a) FIRST.
- ONCE JOINED, TIGHTEN CAM LOCK (c) ONTO BOLT (b) USING PRE-DRILLED HOLES.
- COVER CAM HOLES WITH THE SHORT PLASTIC COVER (n).

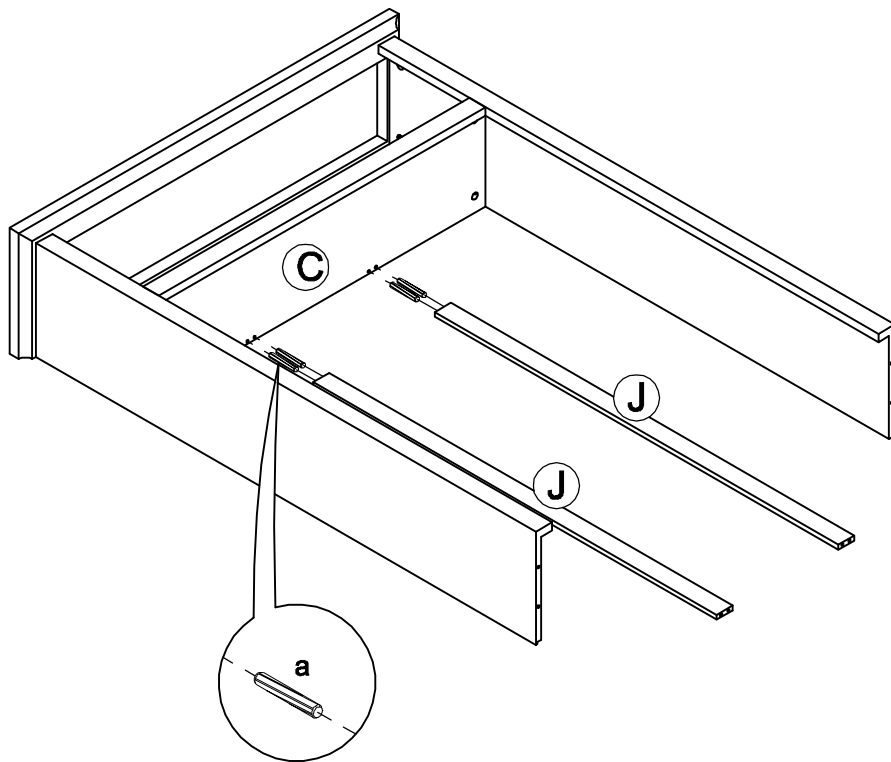
# FIG 2



- INSTALL THE WOOD DOWEL (a) AND THE CAM LOCK BOLT (b) IN TO THE TOP PANEL (D).
- JOIN THE TOP PANEL (D) TO THE ASSEMBLED PART BY USING THE WOOD DOWEL (a) FIRST.
- ONCE JOINED, TIGHTEN CAM LOCK (c) ONTO BOLT (b) USING PRE-DRILLED HOLES.
- COVER CAM HOLES WITH THE LONG PLASTIC COVER (k).

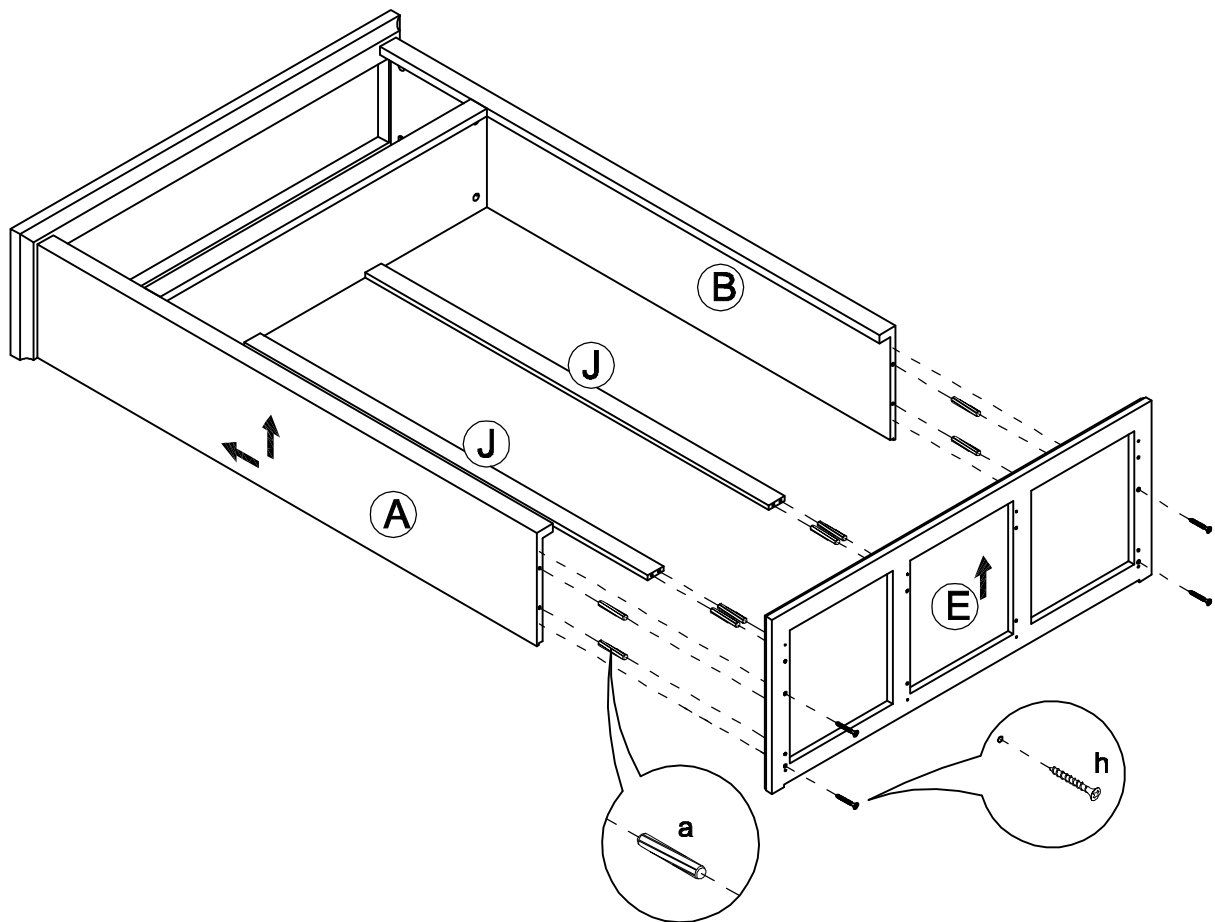


# FIG 3



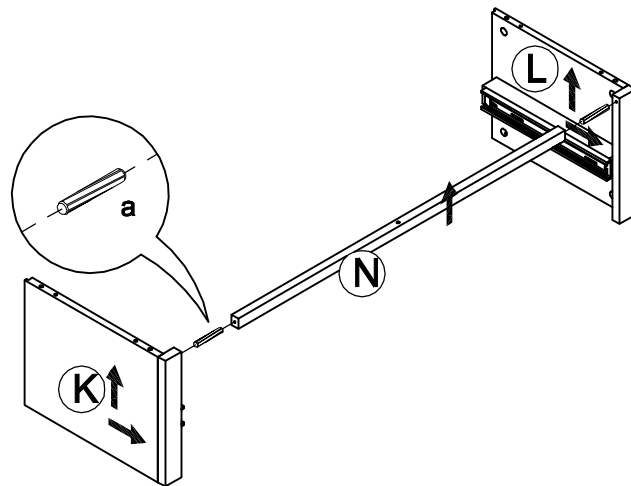
- INSTALL THE WOOD DOWEL (a) INTO THE BACK SUPPORT SLATS (J).
- JOIN THE BACK SUPPORT SLATS (J) TO THE ASSEMBLED PART BY USING THE WOOD DOWEL (a).

FIG 4



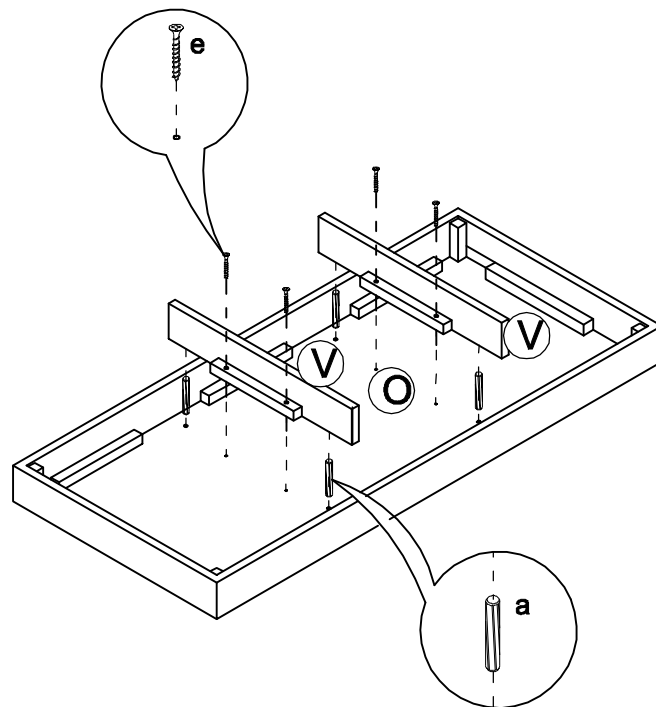
- INSTALL THE WOOD DOWEL (a) INTO TOP OF THE FIXED PANEL (E).
- JOIN THE FIXED PANEL (E) TO THE ASSEMBLED PART BY USING THE WOOD DOWEL (a).
- TIGHTEN THE FIXED PANEL (E) TO THE ASSEMBLED PART BY USING THE 1-1/2" L FLAT HEAD SCREW (h) THROUGH PRE-DRILLED HOLES FROM BOTTOM OF THE FIXED PANEL (E).

# FIG 5



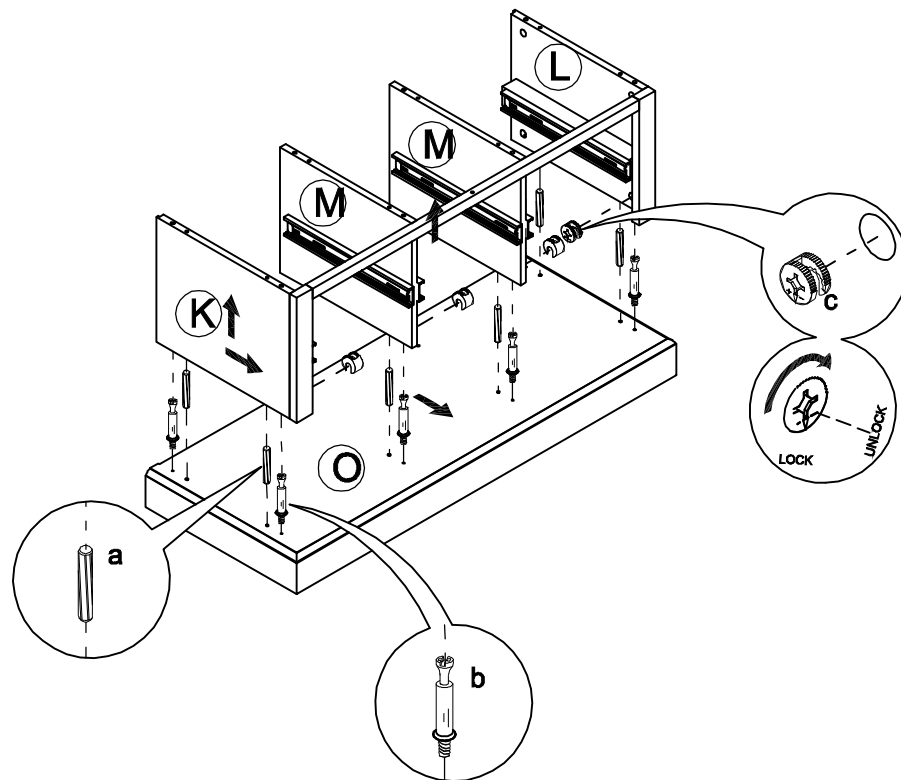
- INSTALL THE WOOD DOWEL (a) TO THE FRONT CROSS BAR (N).
- JOIN THE LOWER LEFT SIDE PANEL (K) AND THE LOWER RIGHT SIDE PANEL (L) TO THE FRONT CROSS BAR (N).

# FIG 6



- INSTALL THE WOOD DOWEL (a) INTO BOTTOM OF THE BOTTOM PANEL (O).
- JOIN THE SUPPORT PANELS (V) TO THE BOTTOM PANEL (O) BY USING THE WOOD DOWEL (a) FIRST.
- TIGHTEN THE SUPPORT PANELS (V) TO THE BOTTOM PANEL (O) BY USING THE 1" L FLAT HEAD SCREW (e).

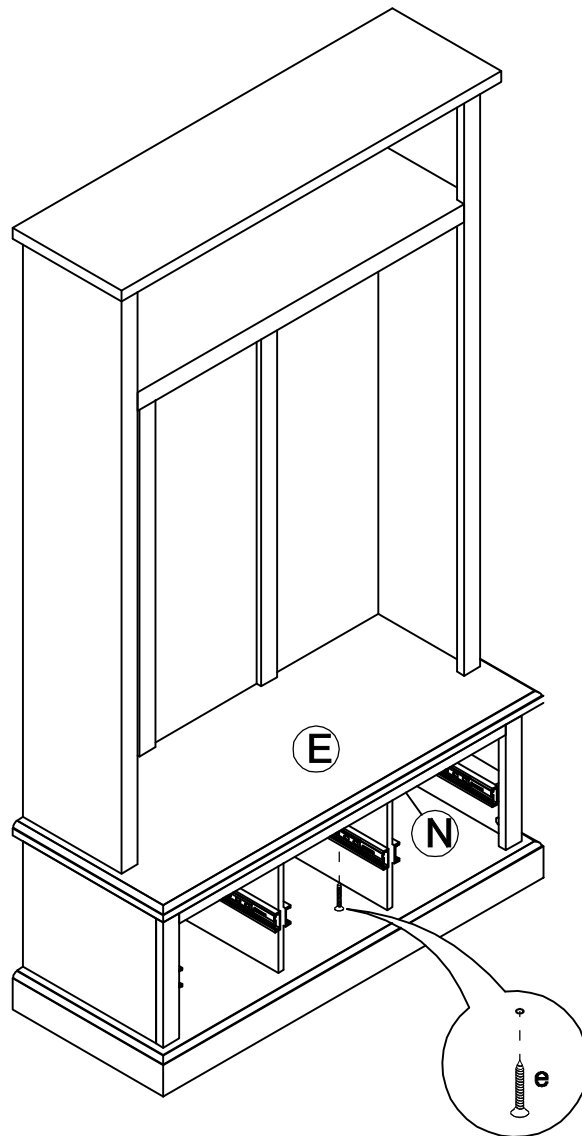
# FIG 7



- INSTALL THE WOOD DOWEL (a) AND THE CAM LOCK BOLT (b) INTO TOP OF THE BOTTOM PANEL (O).
- JOIN THE LOWER LEFT SIDE PANEL (K), THE LOWER RIGHT SIDE PANEL (L), AND THE DIVIDERS (M) TO THE BOTTOM PANEL (O) BY USING WOOD DOWEL (a) FIRST.
- ONCE JOINED, TIGHTEN CAM LOCK (c) ONTO BOLT (b) USING PRE-DRILLED HOLES.

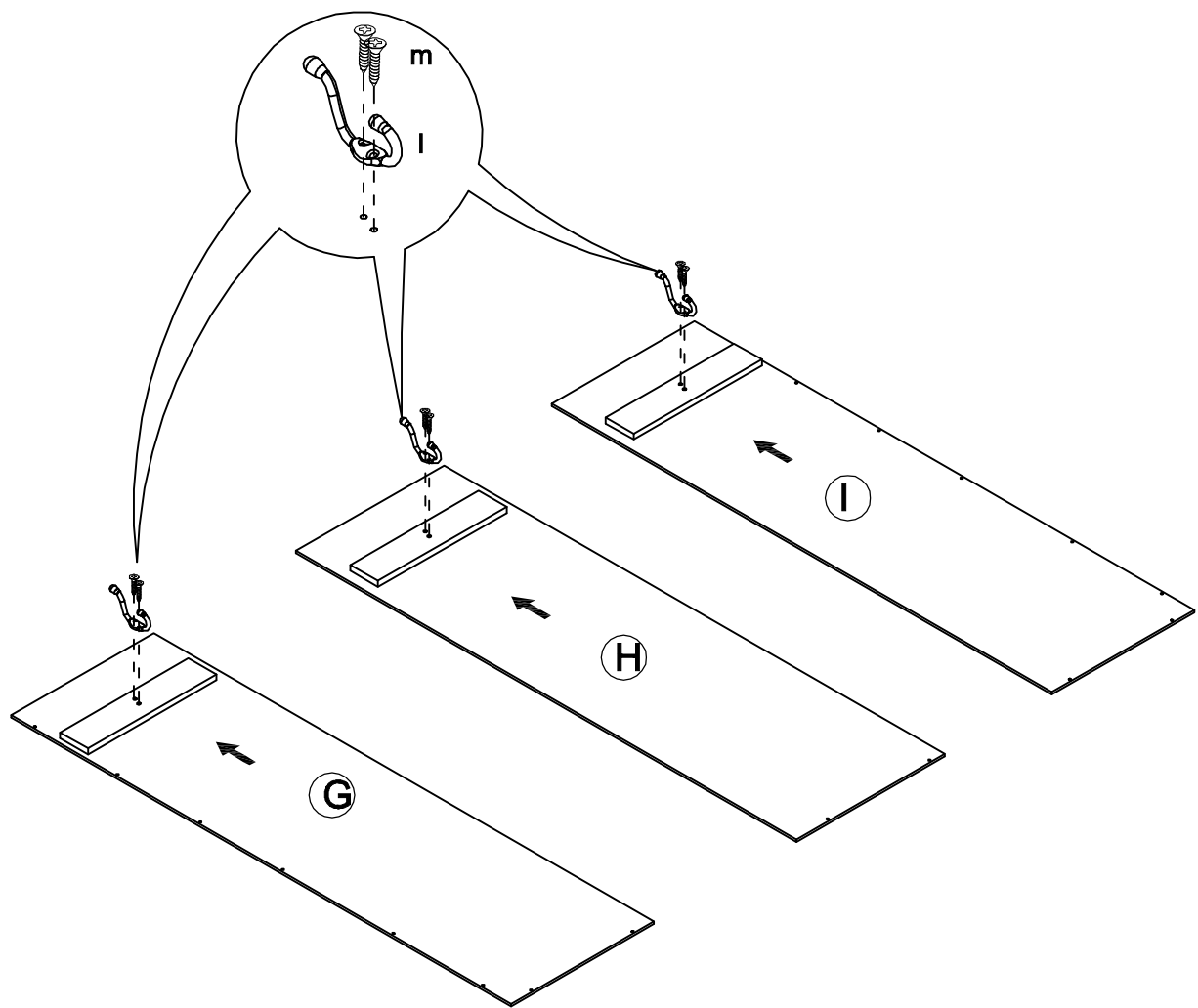


FIG 9



- TIGHTEN THE FRONT CROSS BAR (N) TO THE FIXED PANEL (E) BY USING THE 1" L FLAT HEAD SCREW (e).

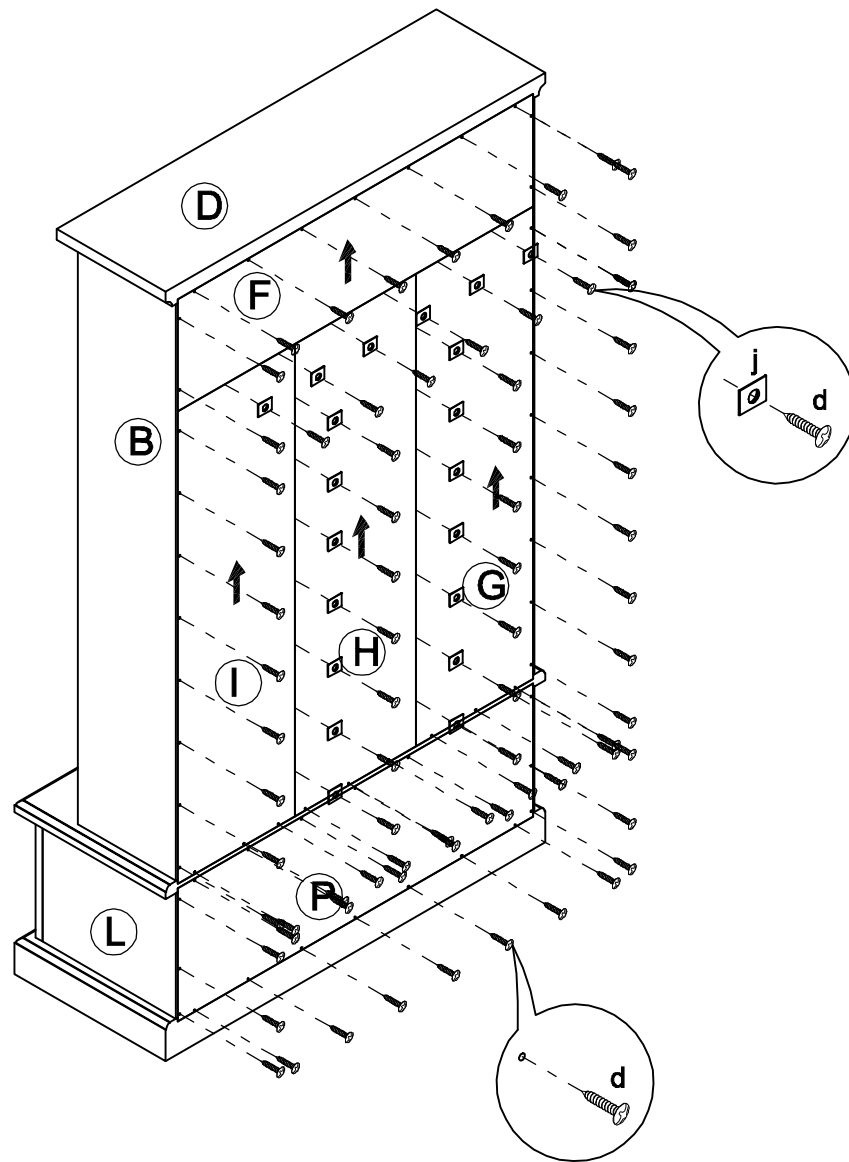
FIG 10



- ATTACH THE DOUBLE HOOK (I) TO THE LEFT BACK PANEL (G), THE CENTER BACK PANEL (H), AND THE RIGHT BACK PANEL (I) BY USING THE 1/2" L FLAT HEAD SCREW (m).

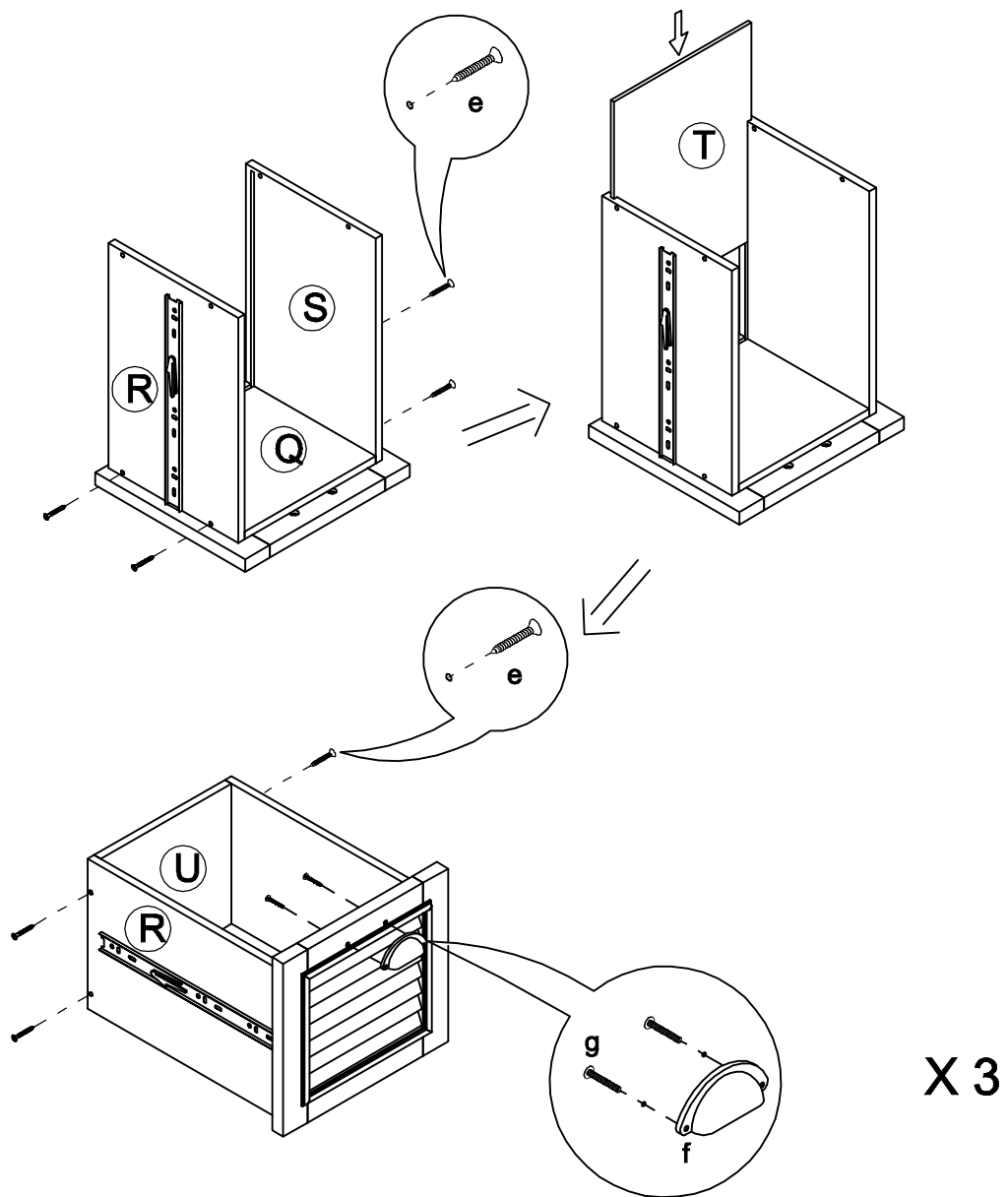


FIG 11



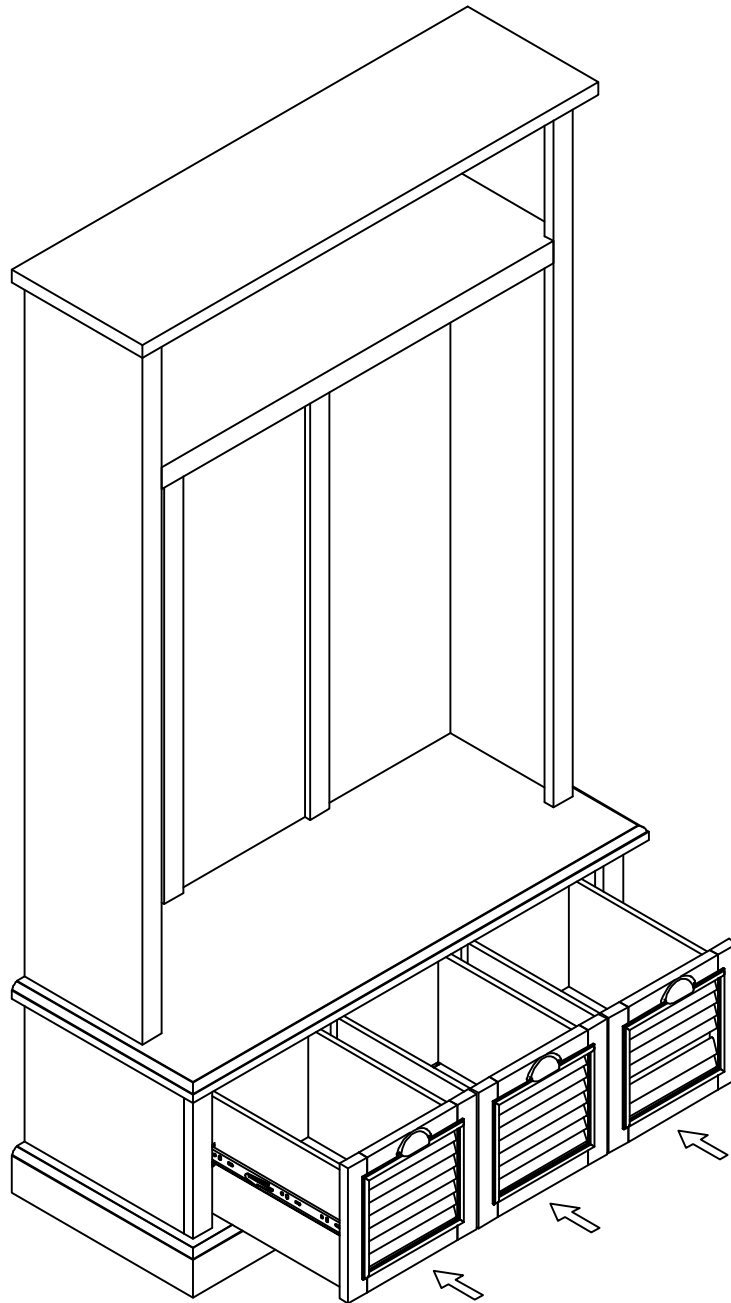
- TIGHTEN THE LEFT BACK PANEL (G), THE CENTER BACK PANEL (H), THE RIGHT BACK PANEL, AND THE UPPER BACK PANEL BY USING THE 5/8" L ROUND HEAD SCREW (d) AND THE METAL PLATE (j).

# FIG 12



- TIGHTEN THE DRAWER LEFT SIDE PANEL (R) AND THE DRAWER RIGHT SIDE PANEL (S) TO DRAWER FRONT PANEL (Q) BY USING THE 1" L FLAT HEAD SCREW (e).
- SLIDE THE DRAWER BOTTOM PANEL (T) TO THE GROOVES ON DRAWER THE DRAWER LEFT SIDE PANEL (R) AND THE DRAWER RIGHT SIDE PANEL (S).
- TIGHTEN THE DRAWER BACK PANEL (U) TO THE ASSEMBLED PART BY USING THE 1" L FLAT HEAD SCREW (e).
- TIGHTEN THE HALF ROUND HANDLE (f) TO THE DRAWER FRONT PANEL (Q) BY USING THE HANDLE BOLT (g).
- REPEAT STEPS ABOVE FOR THE 2<sup>ND</sup> DRAWER AND THE 3<sup>RD</sup> DRAWER.

FIG 13



- INSERT ASSEMBLED DRAWERS TO THE ASSEMBLED PART SLIDE THE ASSEMBLED DRAWERS TO THE ASSEMBLED UNIT.