

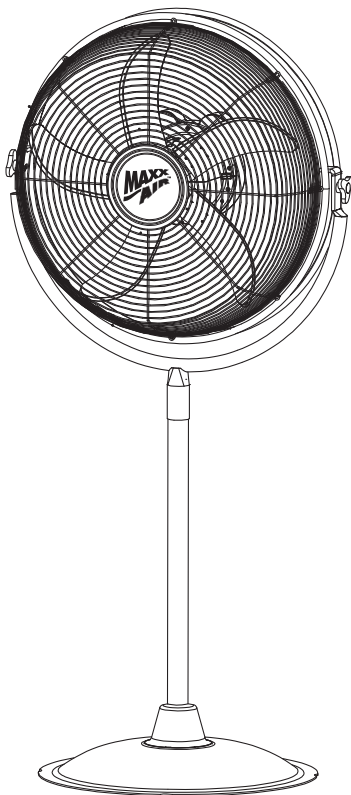

20 IN. OUTDOOR PEDESTAL FAN

MODEL #: HVPF-20 OR

English



Questions, problems, missing parts? Before returning to your retailer, call our customer service department at 1-800-433-1626

PACKAGE CONTENTS

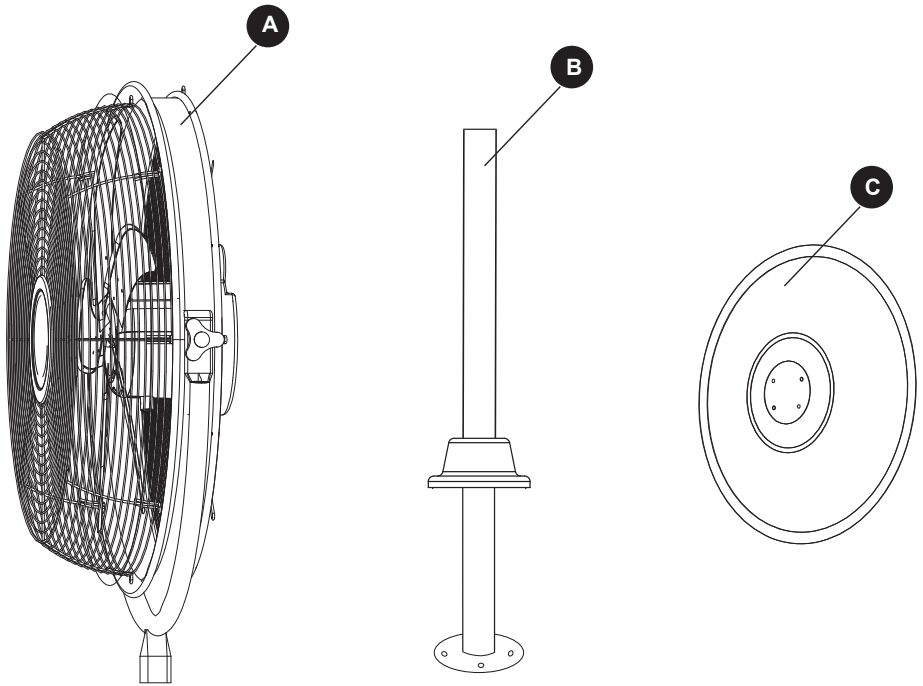

PART	DESCRIPTION	QUANTITY
A	Fan Body	1
B	Stand Pole	1
C	Base	1

AA

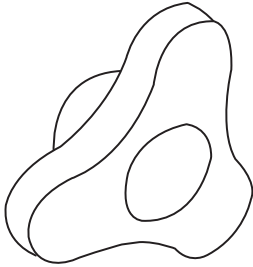

Plastic Nut Tightener
Qty. 2
(preassembled)

BB



Screw
Qty. 2

CC



Spring Washer
Qty. 2



SAFETY INFORMATION

Please read and understand this entire manual before attempting to assemble, operate or install the product. If you have any questions regarding the product, please call customer service at 1-800-433-1626

WARNING

PLEASE READ AND SAVE THESE INSTRUCTIONS.

- When using electric products, basic safety precautions should always be followed to reduce the risk of fire, electric shock, and personal injury. Follow these important safety guidelines.
- Do not use this fan with any solid-state speed control device.
- Do not use an extension cord with this fan.
- Do not expose to rain. Store indoors.
- Do not use with damaged cord, plug or other parts.
- Keep cord away from heated surface.
- Do not handle plug or the fan with wet hands.
- Do not touch the terminals of plug when installing or removing the plug from the outlet.
- Unplug or disconnect the fan from power supply before servicing.
- After servicing, any safety device (including grilles, impeller, etc.) should be reinstalled or remounted as previously installed.
- This product is not intended for use by persons (including children) with reduced physical, sensory or mental capabilities, or lack of experience and knowledge, unless they are given supervision or instruction concerning use of the product by a person responsible for their safety. Children should be supervised to ensure that they do not play with this product.

WARNING

- THE POWER CORD is equipped with a three-prong, grounded GFCI (Ground Fault Circuit Interrupter) plug that must be inserted into a grounded receptacle or GFCI power outlet. Under no circumstances must the grounding prong be cut off the plug.

CAUTION

- CONSIDER YOUR WORK AREA ENVIRONMENT. Don't operate fan in presence of flammable liquids or gases like gasoline or other fuels, lighter fluid cleaners, oil-based paints, natural gas, hydrogen, coal dust, magnesium dust, grain dust, or explosive dust like powder. Do not use or store near hazardous or toxic materials.
- USE SAFETY GLASSES. Also use face or dust mask if work area is dusty. The operation of any fan can result in foreign objects being blown into the eyes, which can result in severe eye damage. Always wear safety goggles complying with ANSI Z87.1.
- DON'T ABUSE CORD. Never pull the power cord or yank it to disconnect from receptacle. To unplug, grasp the plug, not the cord. Keep cord away from heat, oil, and sharp edges. Do not pull or carry by cord, use cord as handle, close a door on cord, or pull around sharp edges or corners.
- MAINTAIN fan. Keep fan clean at all times. Keep dry, clean and free from moisture.
- DISCONNECT fan when not in use. Don't operate unit unattended.
- NEVER stick any object into the grille openings of the fan.
- RETURN for repair or to replace damaged parts if any are found to be broken or if the fan is inoperative.
- IF the supply cord is damaged, it must be replaced by the manufacturer, its service agent or similarly qualified persons in order to avoid a hazard.

PREPARATION

Before beginning assembly of product, make sure all parts are present. Compare parts with package contents list and hardware contents list. If any part is missing or damaged, do not attempt to assemble or operate the product.

Estimated Assembly Times: 30 minutes

Tools Required for Assembly: Phillips Screwdriver (not included)

ASSEMBLY INSTRUCTIONS

1. Attach stand pole (B) to the base (C) and secure with 4 screws (BB) and 4 spring washers (CC)
Make sure all screws are tightened firmly.

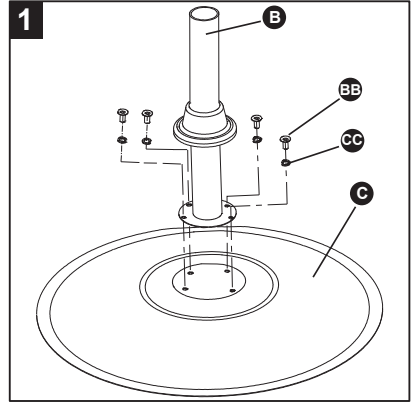

HARDWARE USED

BB Screw



x 4

CC Spring Washer



x 4

ASSEMBLY INSTRUCTIONS

2. Attach the fan body (A) to the stand pole (B). Align holes on the pole of fan body (A) and attach 2 screws (BB) and 2 spring washers (CC), then tighten the screws (BB) **firmly**.

To adjust air flow up and down, tilt the fan to the desired angle. Tighten the plastic nut tightener (AA) on both tilt nuts to secure fan head.

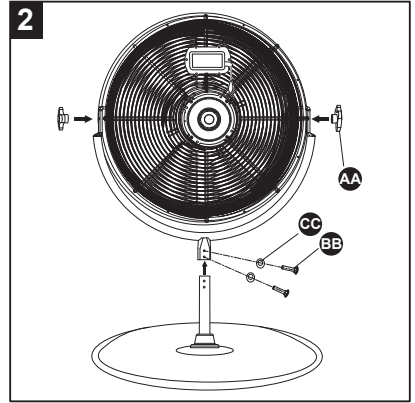

HARDWARE USED

AA Plastic Nut Tightener



x 2

BB Screw



x 2

CC Spring Washer



x 2

OPERATING INSTRUCTIONS

1. Test GFCI (Ground Fault Circuit Interrupter) plug **BEFORE EACH USE**.
 - Plug GFCI into power outlet. Press RESET button (A). Indicator (B) should turn red.
 - Press TEST button (C). Indicator (B) should turn off. GFCI plug is tripped.
 - Press RESET button (A) again for use.
 - **DO NOT USE FAN IF ABOVE TEST FAILS.** Call customer service department for assistance.

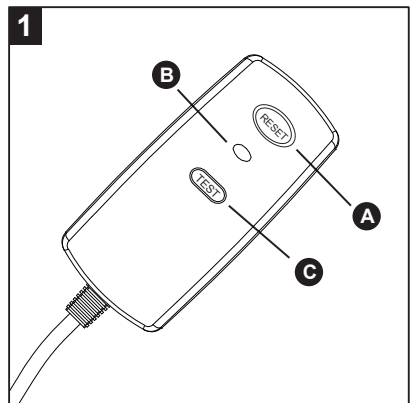

OPERATING INSTRUCTIONS

2. ADJUSTING AIR SPEED

The fan has three speeds (LOW, MEDIUM and HIGH).

Pull the chain of the speed control switch on the back of the unit to adjust air flow to desired speed.

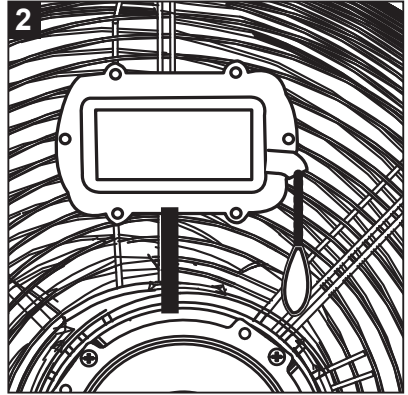

CARE AND MAINTENANCE

- Unplug from electrical source to clean.
- Use soft, damp cloth to clean. Following that, wipe with clean, dry cloth.
- Do not bend the fan blades.
- Store in a dry place.

TROUBLESHOOTING

Before returning to your retailer, call our customer service department at 1-800-433-1626

PROBLEM	POSSIBLE CAUSE	CORRECTIVE ACTION
Fan won't run.	<ol style="list-style-type: none">1. Fan is not plugged in.2. Unit is not turned on.3. GFCI needs to be reset.	<ol style="list-style-type: none">1. Make sure unit is plugged in.2. Check that unit is turned on.3. Unplug fan and follow the instructions on page 6 to reset GFCI plug.
Oscillating feature not working.	<ol style="list-style-type: none">1. Oscillating feature is not turned on.	<ol style="list-style-type: none">1. Make sure that oscillation switch is turned on.

VENTAMATIC, LTD. LIMITED WARRANTY

Ventamatic, Ltd. extends this warranty to the original retail purchaser of its model or, if this unit is purchased and installed by a building contractor, then to the original owner of the home. No subsequent purchaser of the unit or of a home which it is installed is entitled to any of the benefits of this warranty.

This product is warranted against defects in materials and workmanship for a period of one (1) year from the date of original retail purchase. No other parts or components are warranted. There is no warranty for defects caused by abuse, faulty installation, or the like. Repairs or replacement parts supplied under this warranty are warranted only for the period of this warranty; that is, one (1) year from the date of the original retail purchase of the unit.

In the event of a defect or malfunction, we will replace or repair the defective part or component only and return the new or repaired part to you freight prepaid. You must bear all other expenses incurred in obtaining repairs, including labor required for old repair or replacement, and the cost of shipping the defective part to us. You must also bear the cost of repair to or replacement of any part or component and the shipping charges incurred for the repair or replacement and return to you of any part or component not covered by this warranty, including parts or components damaged by you.

The company reserves the right to demand and receive written evidence of the date of purchase before undertaking to perform its obligations under this warranty. You should, therefore, retain your sales slip and attach a copy of it to the warranty claim. In order to obtain the repair or replacement of this unit, you must select one of the following methods:

A. Return to factory.

Return postage prepaid only the part or component which you believe to be defective to the following address:

Ventamatic, Ltd.
100 Washington Street
Mineral Wells, TX 76067

*Complete and enclose a written claim
and attach a copy of your sales slip or
other proof of purchase.

B. Return to retail dealer.

If the retail dealer from whom you purchased this unit stocks replacement parts or components, you may return a part or component which you believe to be defective to that dealer for replacement.

CAUTION: ONLY A LIMITED NUMBER OF OUR RETAIL DEALERS STOCK REPLACEMENT PARTS. IF YOUR DEALER DOES NOT, YOU MUST RETURN THE PART TO THE FACTORY FOLLOWING THE PROCEDURE DESCRIBED IN PARAGRAPH "A" ABOVE.

There is no informal dispute settling mechanism available in the event of a controversy involving this warranty.

Any and all implied warranties which may exist terminate upon the expiration of this warranty one (1) year from the date of the original retail purchase. Some states do not allow limitations on how long an implied warranty lasts, so this limitation may not apply to you.

Ventamatic, Ltd. is not liable to you for incidental or consequential damages arising out of a defect or malfunction of a unit or its installation or out of any alleged breach of this warranty. Some states do not allow the exclusion or limitation of incidental or consequential damages, so this limitation may not apply to you.

This warranty gives you specific legal rights and you may also have other rights which may vary from state to state.

REPLACEMENT PARTS LIST

PART	DESCRIPTION
A	Fan Motor
B	Stand Pole
C	Base
D	Fan Blade
E	Speed Switch
F	Power Cord
G	U Arm
H	Drum
I	Rear Grille
J	Front Grille
K	Cover Ring
AA	Plastic Tightener

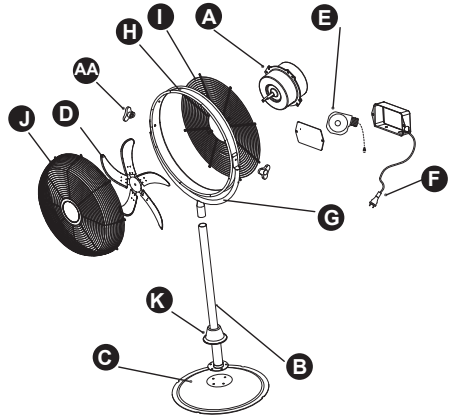

TECHNICAL DATA

VOLTAGE/FREQUENCY	CURRENT	POWER CONSUMPTION
120 V/60 Hz	1.1 A	120W