

Item # GEN1000



1,000 MAX WATTS INVERTER GENERATOR

INSTRUCTION MANUAL

READ ALL INSTRUCTIONS AND WARNINGS BEFORE USING THIS PRODUCT.

This manual provides important information on proper operation & maintenance. Every effort has been made to ensure the accuracy of this manual. These instructions are not meant to cover every possible condition and situation that may occur. We reserve the right to change this product at any time without prior notice.

IF THERE IS ANY QUESTION ABOUT A CONDITION BEING SAFE OR UNSAFE, DO NOT OPERATE THIS PRODUCT!

DO NOT RETURN THIS GENERATOR TO THE RETAILER!

If you experience a problem, have questions or need parts for this product, call Customer Service at **1-866-460-9436, Monday-Friday, 8 AM - 4 PM Central Time**. A copy of the sales receipt is required.

FOR CONSUMER USE ONLY – NOT FOR PROFESSIONAL USE.

KEEP THIS MANUAL, SALES RECEIPT & APPLICABLE WARRANTY FOR FUTURE REFERENCE.

CALIFORNIA PROPOSITION 65

WARNING: This product, or the exhaust from this generator, may contain chemicals, including lead, known to the State of California to cause cancer and birth defects or other reproductive harm. Wash hands after handling.

2 YEAR LIMITED EMISSION-RELATED WARRANTY

THIS ENGINE MEETS U.S. EPA EMISSION STANDARDS UNDER 40 CFR 1054.625. The emission-related limited warranty is valid for two (2) years. Keep the purchase receipt and mail in the product registration card for proof of purchase. Buffalo Corp limits emission-related warranty repairs to authorized service centers for owners located within 100 miles of an authorized service center. For owners located more than 100 miles from an authorized service center, Buffalo Corp will, in its sole discretion, either pay for shipping costs to and from an authorized service center, provide for a service technician to come to the owner to make the warranty repair, or pay for the repair to be made at a local non-authorized service center. The provisions of this paragraph apply only for the contiguous states, excluding the states with high-altitude areas identified in 40 CFR part 1068, Appendix III.

To exercise this warranty, **DO NOT RETURN TO RETAILER**. Instead, call Customer Service toll free at 1-866-460-9436 (email address info@buffalotools.com) and you will be instructed on where to take the engine for warranty service. Take the generator and proof of purchase (your receipt) to the repair facility recommended by the Customer Service Representative. The warranty does not extend to generators damaged or affected by fuel contamination, accidents, neglect, misuse, unauthorized alterations, use in an application for which the product was not designed and any other modifications or abuse.

1 YEAR LIMITED WARRANTY (30 Day Limited for Commercial/Rental Purpose)

Generators are warranted to be free from defects in materials and workmanship for a period of 1 YEAR from date of original purchase. Buffalo Corp. is not liable for any indirect, incidental or consequential damages from the sale or use of this product. Any implied warranties are limited to 1 YEAR as stated, or as otherwise stated, in this written limited warranty. Some states do not allow the exclusion or limitation of incidental or consequential damages. Some states do not allow limitation on the length of an implied warranty. Buffalo Corp will repair or replace, at its discretion, any part that is proven to be defective in materials or workmanship under normal use during the 1 YEAR warranty period. Warranty repairs or replacements will be made without charge for parts or labor. Parts replaced during warranty repairs will be considered as part of the original product and will have the same warranty period as the original product. This warranty gives you specific legal rights, and you may have other rights that vary state to state.

Notice Regarding Emissions:

Engines certified to comply with California and U.S. EPA emission regulations for SORE (Small Off Road Equipment) are certified to operate on regular unleaded gasoline and may include the following emission control systems: Three-Way Catalyst (TWC) (if equipped), and Engine Modifications (EM).

Legal Requirements:

Federal and/or State Occupational Safety and Health Administration (OSHA) regulations, local codes, and/or ordinances may apply to the intended use of this generator. Consult a qualified electrician, electrical inspector, and/or the local agency having jurisdiction. Some areas require generators to be registered with local utility companies. Additional regulations may apply if this generator will be used at a construction site.

IMPORTANT SAFETY INSTRUCTIONS

STOP!

Before using this generator and if you have any questions regarding the hazard and safety notices listed in this manual and/or on this generator, call 1-866-460-9436, Monday - Friday, 8 AM - 4 PM Central Time.

DANGER

Carbon Monoxide Gas: When in operation, the exhaust from this generator contains poisonous carbon monoxide gas. Carbon monoxide gas is both odorless and colorless AND may be present even if you do not see or smell gas. Breathing this poison gas can lead to headaches, dizziness, drowsiness, loss of consciousness and eventually death.

- USE THIS GENERATOR ONLY OUTDOORS IN NON-CONFINED AREAS. DO NOT SECURE THE GENERATOR WITH A CHAIN OR ROPE, AS THIS WILL MAKE IT DIFFICULT TO MOVE IN AN EMERGENCY.
- Keep at least several feet of clearance on all sides to allow proper ventilation for this generator.

WARNING

Chemicals: According to the State of California, the exhaust from this generator contains chemicals known to cause cancer, birth defects, or other reproductive harm.

⚠ WARNING

Flammable Gasoline: This generator may emit highly flammable and explosive gasoline vapors, which can cause severe burns or even death. A nearby open flame can lead to an explosion even if not directly in contact with gasoline.

- Do not operate this generator near open flame.
- Do not smoke near this generator.
- Always operate this generator on a firm, level surface.

Gasoline is highly flammable and explosive. Handling fuel can result in serious injury or burns.

- Always shut down this generator before refueling. Refuel in a well-ventilated area. Keep heat, sparks and flame away while refueling and away from the location where gasoline is stored. Never refuel indoors where gasoline fumes may reach flames and/or sparks.
- Allow this generator to cool for at least 2 minutes before removing the fuel tank cap. Loosen the cap slowly to relieve pressure in the fuel tank. Avoid spilling fuel.
- Do not fill the fuel tank above the upper limit line. Gasoline may expand during operation. Do not fill to the top of the tank.
- Always check for spilled gasoline and immediately wipe it up before starting this generator.
- Empty the fuel tank before storing or transporting this generator.
- Always handle fuel outdoors.
- Before transporting, turn the fuel valve to the “OFF” position and disconnect the spark plug.

NOTE: DO NOT USE GASOLINE CONTAINING MORE THAN 10% ETHANOL (e10)

⚠ WARNING

Usage: Consult a physician(s) before using this generator if using a pacemaker. Electromagnetic fields in close proximity to a heart pacemaker could cause a pacemaker to malfunction or fail. Caution is necessary when near the engine’s recoil starter.

⚠ CAUTION

Usage: Prolonged exposure to high noise levels can be hazardous to hearing. Always wear ANSI-approved hearing protection when operating or working around the generator when it is running.

⚠ DANGER

Powerful Voltage: This generator produces powerful voltage, which can result in electrocution.

- ALWAYS ground this generator before using it. (See “Ground the Generator” section in this manual).
- Only electrical devices should be plugged into this generator, either directly or with an extension cord. NEVER connect a building electrical system to this generator without a qualified electrician. *Doing so voids your warranty.* Such connections must isolate generator power from utility power and comply with local electrical laws and codes. Failure to comply can create a back feed into utility lines creating an electrocution hazard, which may result in serious injury or death to utility workers. Such a back feed may cause this generator to explode, burn and create fires when utility power is restored.
- Use a ground fault circuit interrupter (GFCI) in highly conductive areas such as metal decking or steel work. GFCIs are available in-line with some extension cords.
- Do not use this generator in wet conditions (rain, snow, active sprinkler system, wet hands, etc.). Always keep this generator dry and operate it with dry hands.
- Do not allow children or non-qualified persons to operate this generator.

⚠ WARNING

GASOLINE IS HIGHLY FLAMMABLE AND EXPLOSIVE. YOU COULD BE BURNED OR SERIOUSLY INJURED IF THE GASOLINE IS IGNITED. Before refueling, stop the engine and keep heat, sparks and flame away. Handle fuel only outdoors. Do not fill the fuel tank above the upper limit line. Wipe up spills immediately.

⚠ WARNING

IMPROPER CONNECTIONS TO A BUILDING CAN ALLOW ELECTRICAL CURRENT TO BACKFEED INTO UTILITY LINES, CREATING AN ELECTROCUTION HAZARD. Connections to a building must isolate generator power from utility power and comply with all applicable laws and electrical codes.

⚠ DANGER

High Temperatures: This generator produces heat when in operation. Temperatures near the exhaust can exceed 150 Degrees Fahrenheit (65 Degrees Celsius).

- Do not touch hot surfaces. Observe all warning placards on this generator denoting hot surfaces.
- Allow this generator to cool for several minutes after use before touching the engine, muffler or other areas that are hot during operation and before storing indoors.
- Hot exhaust may ignite some materials. Keep flammable materials away from this generator.
- Keep at least several feet of clearance on all sides of this generator during operation. Do not enclose this generator in any structure.

⚠ CAUTION

Usage: Misuse of this generator can damage it or shorten its life.

- Use this generator only for its intended purpose.
- Operate this generator only on a dry, level surface. Do not secure the generator with a chain or rope, which would prevent it from being moved in an emergency.
- Allow this generator to run for several minutes before connecting any electrical devices.
- Promptly turn off any malfunctioning devices and disconnect them.
- Do not operate an excessive number of electrical devices in excess of the wattage capacity of this generator.
- Do not turn on electrical devices until *after* they are connected to this generator.
- Turn off all connected electrical devices before stopping this generator.

⚠ CAUTION

Usage: Prolonged exposure to high noise levels can be hazardous to hearing. Always wear ANSI-approved hearing protection when operating or working around the generator when it is running.

⚠ WARNING

Usage: Avoid the use of extension cords if possible. If you choose to use them, be sure they are sized adequately to handle the flow of electricity. An undersized cord can overheat, short out and cause a fire.

Included with this Generator:

DC connector wires for connecting 12 Volt automotive-type batteries
Spark plug wrench
Screwdriver

⚠ WARNING

Usage: Avoid the use of extension cords if possible. If you choose to use them, be sure they are sized adequately to handle the flow of electricity. An undersized cord can overheat, short out and cause a fire.

⚠ WARNING

The engine exhaust from this product contains chemicals known to the State of California to cause cancer, birth defects or other reproductive harm.

⚠ DANGER

EXHAUST CONTAINS POISONOUS CARBON MONOXIDE GAS THAT CAN BUILD UP TO DANGEROUS LEVELS IN CLOSED AREAS. BREATHING CARBON MONOXIDE CAN CAUSE UNCONSCIOUSNESS OR DEATH. Never run the generator in a closed or even partly closed area where people may be present.

FEATURES:

- 0.55 Gallon Fuel Tank
- 1,000 Watts Max/800 W Min AC output
- 5,000 RPM
- 40cc, 4 stroke
- Low oil shutdown
- Recoil Start
- Run Time : 6.3 Hours at 50% load
- Noise Level : 56db at 0% load @23 Ft
- 1.3 HP
- 7.5 ounces Oil
- EPA / CARB Approved
- High Altitude Use: This generator is not recommended for high altitude use above 3,000 feet.

DESCRIPTION

- | | | |
|----------------------------|------------------------------|------------------------------|
| (1) Economy control switch | (2) Engine switch | (3) Fuel tank |
| (4) Spark plug | (5) Muffler | (6) Carrying handle |
| (7) Choke lever | (8) AC pilot light | (9) Overload indicator light |
| (10) Oil warning light | (11) Ground (earth) terminal | (12) DC protector |
| (13) DC receptacle | (14) AC receptacle | |
| (16) Fuel filter | (17) Fuel tank cap | (18) Fuel pump |
| (19) Recoil starter | (20) Fuel cock | (21) Oil filler cap |
| (22) Air filter cover | | |

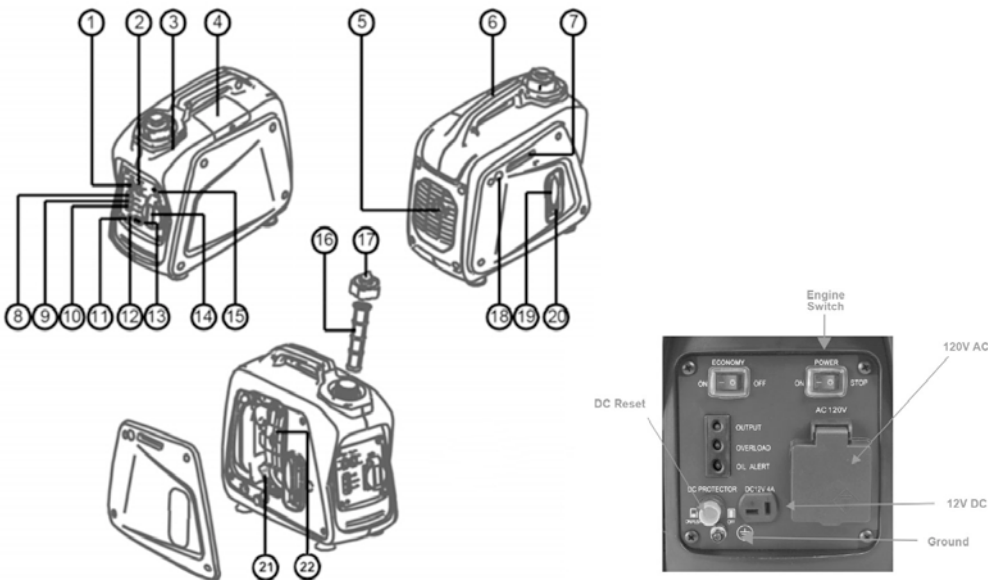

This is a Gasoline Powered Inverter Generator that offers clean power for electronics.

1) ENGINE SWITCH

The engine switch controls the ignition system.

To Start generator, turn POWER switch ON. Then the engine can be started by sliding Choke lever to CHOKE then pull Recoil. Allow engine to run for a few seconds then slide the Choke Lever to OFF.

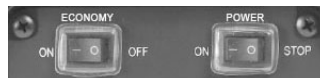

To Stop generator, press POWER switch to STOP. The engine will not run.

2) ECONOMY CONTROL SWITCH

When the economy control switch is turned "ON", the economy control unit controls the engine speed according to the connected load. The results are better fuel connection and less noise. (Turn OFF when using less voltage.)

3) LOW OIL ALERT SENSOR

When the oil level falls below the acceptable level, the engine stops automatically. Unless you refill with oil, the engine will not start again.

4) OVERLOAD INDICATOR LIGHT

The overload indicator light comes on when an overload of a connected electrical device is detected, the inverter unit overheats, or the AC output voltage rises. The electronic breaker will then activate, stopping power to the generation in order to protect the generator and any connected electric devices. The output pilot light will flicker GREEN, the overload indicator light will turn RED, & the engine will stop.

- (a) Turn off any connected electric devices and stop the engine
 - (b) Reduce the total wattage of connected electric.
 - (c) Check for blockages in the cooling air inlet and the control unit & restart engine.
- The generator AC output automatically resets when the engine is stopped and then restarted. The overload indicator light may come on for a few seconds at first when using electric devices that require a large starting current, such as a compressor or a submersible pump. However, this is not a malfunction.

5) DC CIRCUIT PROTECTOR

The DC circuit protector turns off automatically when the load exceeds the generator rated output. Reduce the load to within specified generator rated output if the DC circuit protector turns off.

6) FUEL COCK

The fuel cock is used to supply fuel from the tank to the carburetor.

Turn ON when getting ready to start the generator. Turn OFF when finished using the generator.

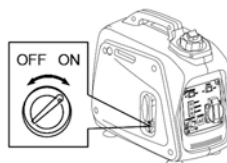

CHECK ENGINE FUEL

- Make sure there is sufficient fuel in the tank.
- If fuel is low, refill with unleaded automotive gasoline.
- Be sure to use the fuel filter screen on the fuel filter neck.
- Recommended fuel: Unleaded gasoline.
- Fuel tank capacity: 0.55 Gallon
- Do not refill tank while engine is running or hot.
- Close fuel cock before refueling with fuel.
- Be careful not to admit dust, dirt, water or other foreign objects into fuel.
- Do not fill above the top of the fuel filter or it may overflow when the fuel heats up later and expands.
- Keep open flames away.

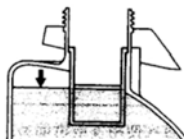

CHECK ENGINE OIL

Remove side panel, then remove oil filler cap and check the engine oil level. Make sure the engine oil is at the upper level of the oil filler hole. Add oil as necessary.

- **WARNING:** The generator has been shipped without engine oil. Fill with oil or it will not start.
- Do not tilt the generator when adding engine oil. This could result in overfilling and damage to the engine
- If oil level is below the lower level line, refill with suitable oil to upper level line. Do not screw in the oil filler cap when checking oil level.
- Oil SAE 10W30 Oil capacity: 7.5 oz.

GROUND

Make sure to ground the generator.

OPERATION

STARTING THE ENGINE

- Before starting the engine, do not connect electric apparatus.

1. Turn the fuel cock lever to the “**ON**” position.
2. Turn the fuel tank cap air vent knob clockwise to the “**OPEN**” position. Turn the engine switch to the “**ON**” or “**RUN**” position.
3. Turn the choke lever to the “Close/Choke” position.
4. PUMP the PRIMER button until the glass bowl is full.

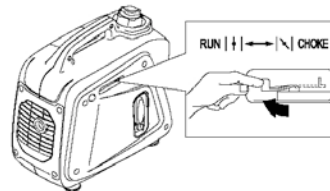
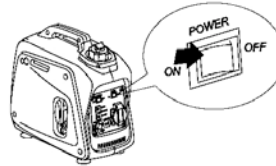
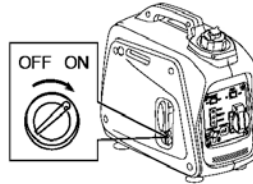

5. Pull the recoil starter handle slowly until resistance is felt. This is the “Compression” point. Return the handle to its original position and pull swiftly. Do not fully pull out the rope. After starting, allow the starter handle to return to its original position while still holding the handle. Grasp the carrying handle firmly to prevent the generator from falling over when pulling the recoil starter.
6. Warm up the engine without a load for a few minutes.
7. Turn the choke lever back to RUN position then plug in appliances.

USING ELECTRIC POWER

AC APPLICATION

- (a) Turn off the switch(es) of the electrical appliance(s) before connecting to the generator.
 - (b) Insert the plug(s) of the electrical appliance(s) into the receptacle.
- Be sure the electric apparatus is turned off before plugging in.
 - Be sure the total load is within generator rated output.
 - Be sure the socket load current is within socket rated current.
 - The economy control switch must be turned to “**OFF**” when using electric devices that require a large starting current, such as a compressor or a submersible pump.

DC APPLICATION

This usage is applicable to 12V battery charging.

Be sure the Economy Control Switch is turned off while charging the battery.

STOPPING THE ENGINE

Turn off the power switch of the electric apparatus or disconnect any electric devices.

Turn the POWER switch to “**STOP**” position.

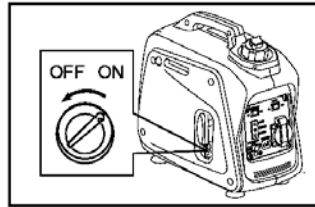

Turn the fuel cock lever to “**OFF**”.

Turn the fuel tank cap air vent knob counterclockwise to the “**CLOSED**” position

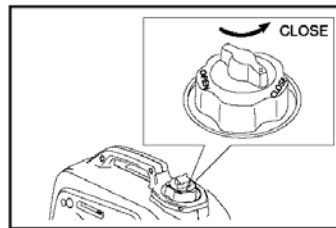

PERIODIC MAINTENANCE

MAINTENANCE CHART

Regular maintenance is important for the best performance and safe operation.

Item	Remarks	Pre-operation check (daily)	Initial 1 months or 20 Hr	Every 3 months or 50 Hr	Every 6 months or 100 Hr	Every 12 months or 300 Hr
Spark Plug	Check condition adjust gap and clean. Replace if necessary.			●		
Engine Oil	Check oil level	●				
	Replace		●		●	
Oil filter	Clean oil filter				●	
Air Filter	Clean. Replace if necessary.			●		
Fuel Filter	Clean fuel cock filter. Replace if necessary				●	
Choke	Check choke operation	●				
Valve Clearance	Check and adjust when engine is cold.					●
Fuel Line	Check fuel hose for crack or damage. Replace if necessary.	●				
Exhaust	Check for leakage. Retighten or replace gasket if necessary	●				

System	Check muffler screen. Clean/replace if necessary.					●
Carburetor	Check choke operation	●				
Cooling system	Check fan damage.					●
Starting system	Check recoil starter operation.	●				
Idle speed	Check and adjust engine idle speed					●
Fittings/ Fasteners	Check all fittings and fasteners correct if necessary.				●	
Crankcase breather	Check breather hose for cracks or damage. Replace if necessary					●
Generator	Check the pilot light comes on	●				

ENGINE OIL REPLACEMENT

1. Place the machine on a level surface and warm up the engine for several minutes. Then stop the engine and turn the fuel cock knob to “OFF”. Turn the fuel tank cap air vent knob clockwise.

2. Loosen the screw and remove the cover.

3. Remove the oil filler cap

4. Place an oil pan under the engine.
Tilt the generator to drain the oil completely

5. Replace the generator on a level surface.

6. Add engine oil to the upper level.

7. Install the oil filler cap

8. Install the cover and tighten the screw

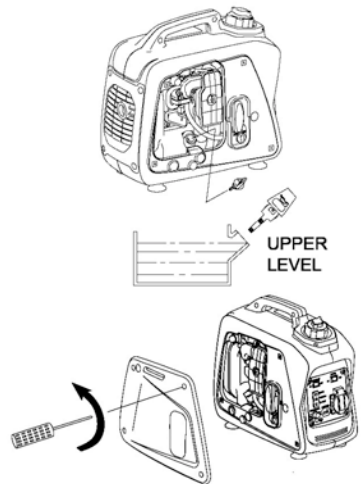

- Engine Oil SAE 10W30 Capacity: 7.5 oz.
- Be sure no foreign material enters the crankcase.
- Do not tilt the generator when adding engine oil. This could result in overfilling and damage to the engine
- Clean the oil filter every other 100 hr.

WASHABLE AIR FILTER

Maintaining an air cleaner in proper condition is very important. Dirt induced through improperly installed, improperly serviced, or inadequate elements damages and wears out engines. Keep the element always clean.

1. Remove the cover.
2. Remove the air filter cover and element.
3. Wash the element in solvent and dry.
4. Oil the element and squeeze out excess oil. The element should be wet but not dripping.
5. Insert the element into the air filter.
6. Install the cover.

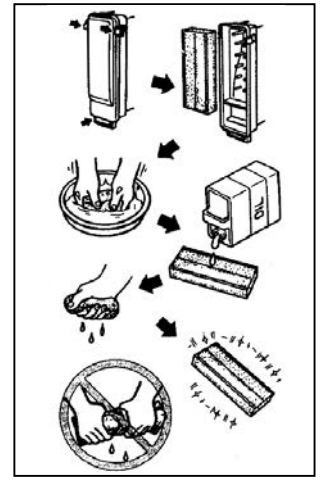

The engine should never run without the Filter; excessive piston and/or cylinder wear may result.

CLEANING AND ADJUSTING SPARK PLUG

1. Remove the cover.
2. Check for discoloration and remove the carbon.
3. Check the spark plug type and gap.
Standard Spark Plug: CMR6A
Spark Plug Gap: 0.6-0.7 mm (0.024-0.028 in)
4. Install the spark plug.
5. Install the cover

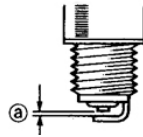

FUEL TANK FILTER

1. Remove the fuel tank cap and filter.
 2. Clean the filter with solvent. If damaged, replace.
 3. Wipe the filter and insert it.
- Be sure the tank cap is tightened securely.



MUFFLER SCREEN

- The engine and muffler will be very hot after the engine has been run.
- Avoid touching the engine and muffler while they are still hot with any part of your body or clothing during inspection or repair.

1. Remove the cover.
2. Remove the muffler screen.
3. Use the flathead screw driver to pry the spark arrester out from the muffler
4. Remove the carbon deposits on the muffler screen and spark arrester using a wire brush.
5. Install the muffler screen.
6. Install the cover

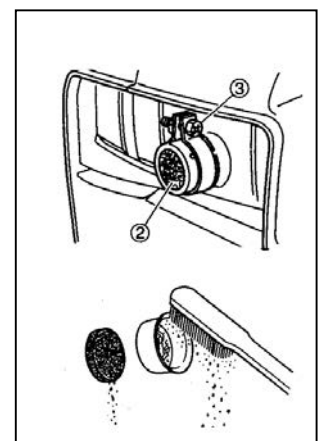
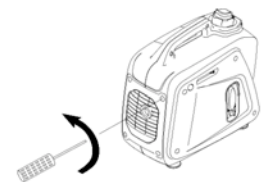

TROUBLE SHOOTING

Engine won't start

1. Fuel systems

No fuel supplied to combustion chamber.

- No fuel in tank....Supply fuel.
- Fuel in tank....Fuel tank cap air vent knob to “**OPEN**”, fuel cock knob to “**OPEN**”.
- Clogged fuel line....Clean fuel line.
- Clogged carburetor....Clean carburetor.

Engine oil system

Insufficient

- Oil level is low....Add engine oil.

Electrical systems

Poor spark

- Spark plug dirty with carbon or wet....Remove carbon or wipe spark plug dry.
- Faulty ignition system....Consult dealer.

Compression insufficient

- Worn out piston and cylinder....Consult dealer.

Generator won't produce power

Safety device (AC) to “OFF” ...Stop the engine, then restart.

Safety device (DC) to “OFF” ...Press to reset the DC protector

STORAGE

Long term storage of your machine will require some preventive procedures to guard against deterioration.

1) DRAIN THE FUEL

1. Remove the fuel tank cap, drain the fuel from the fuel tank.
2. Remove the cover, drain fuel from the carburetor by loosening the carb hose.

2) ENGINE

1. Remove the spark plug, pour in about one tablespoon of SAE 10W30 motor oil into the spark plug hole and reinstall the spark plug.
2. Use the recoil starter to turn the engine over several times (with ignition off).
3. Pull the recoil starter until you feel compression.
4. Stop pulling.
5. Clean exterior of the generator and apply a rust inhibitor.
6. Store the generator in a dry, well-ventilated place, with the cover place over it.
7. The generator must remain in a vertical position.

SPECIFICATION

MODEL		GEN1000i	
GENERATOR	Type	Invertor Generator	
	AC Voltage	60Hz	120V
	Max. Output	1.00 kVA	
	Rated Output	0.80 kVA	
	Power Factor	1.0	
	DC Output	12V/4.0A	
ENGINE	Model	XY139F-6	
	Type	Air-cooled, 4 cycle, OHV, Gasoline Engine	
	Bore×Stroke mm×mm	39×33.5	
	Displacement	40 cc	
	Max. Output	0.9KW/5500rpm	
	Fuel	Regular Automobile Gasoline	
	Fuel tank Capacity	0.55 Gallon	
	Rated Continuous Operation	6.3 hr @ 50% load	
	Lubricating oil	SAE 10W30	
	Lubricating oil Capacity	7.5 ounce	

	Starting System	Recoil Starter
	Ignition system	C.D.I.
	Spark Plug: Type	CMR6A (TORCH)
DIMENSION	Net dimension L×W×H	395×209×355
	Overall dimension L×W×H	425×230×380
	Net Weight	9.2Kg
	Gross Weight	11.4Kg

- Specifications subject to change without prior notice.

- High Altitude Use: This generator is not recommended for high altitude use above 3,000 feet.

STORAGE INSTRUCTIONS

Long term storage of your machine will require some preventive procedures to guard against deterioration.

1. DRAIN THE FUEL

Remove the fuel tank cap, drain the fuel from the fuel tank

2. ENGINE

Remove spark plug, pour in about one tablespoon of SAE 10W30 motor oil into the spark plug hole and reinstall spark plug. Use the recoil starter to turn the engine over several times (with ignition off).

Pull the recoil starter until you feel compression.

Stop pulling.

Clean exterior of the generator and apply a rust inhibitor.

Store the generator in a dry, well-ventilated place, with the cover place over it.

The generator must remain in a vertical position

WIRING DIAGRAM

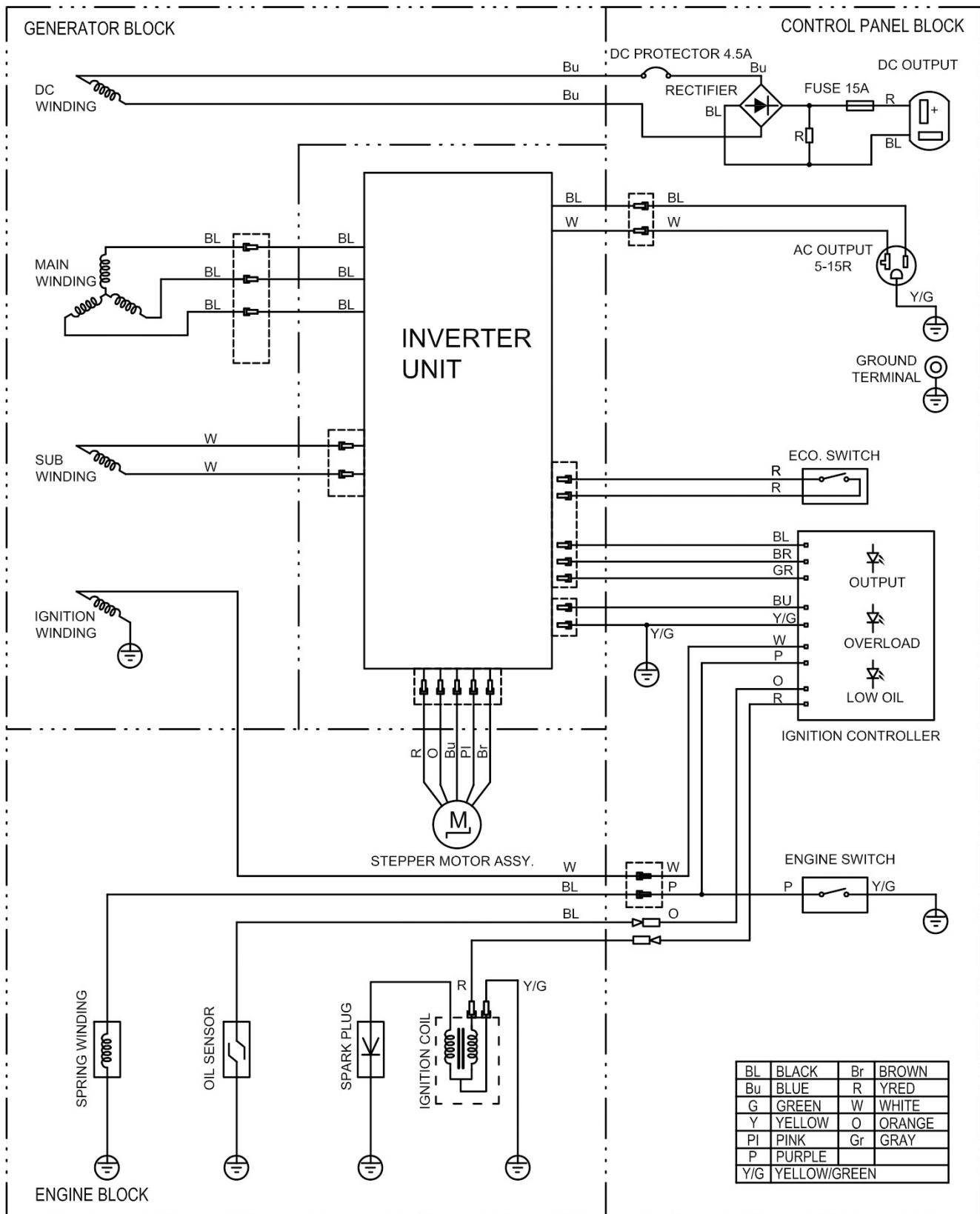

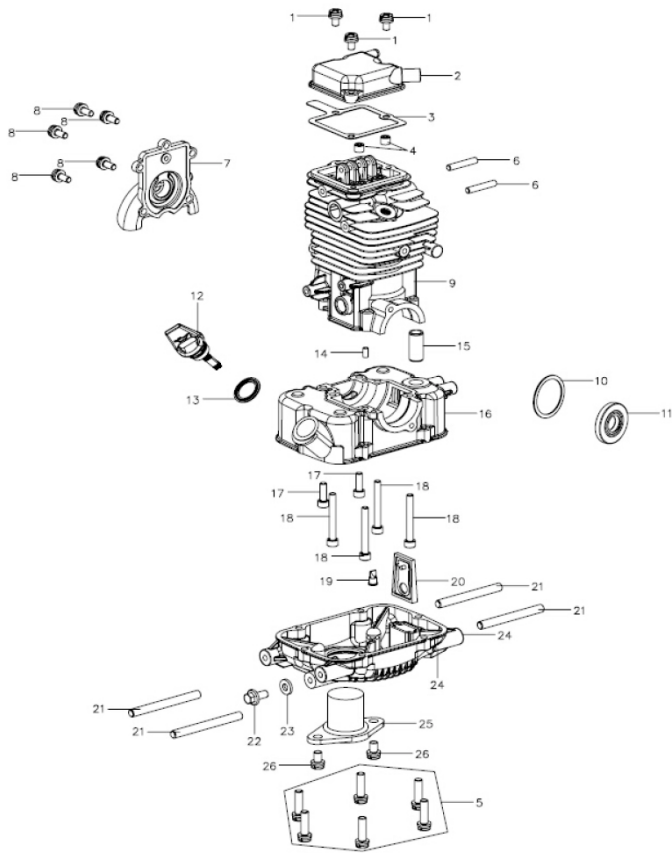

FIG. A CRANKCASE ASSY

No.	Part No.	Description	Qty
1	00252000502011	Screw M5×20	3
2	14760100001001	Cylinder Head Cover	1
3	14760100002011	Cylinder Head Cover Seal	1
4	14760101001001	Valve Oil Seal	2
5	00252000502511	Dual-Head Bolts M5×70	6
6	14760100005041	Dual-Head Bolts M5×28	2
7	14760100003001	Cam Chamber Cover	1
8	00252000501411	Screw M5×14	5
9	14810101000101	Upper Crankcase	1
10	14770100004041	Washer 30×37×1	1
11	14760100007102	Oil Seal 15×35×5	1
12	14760102101003	Oil Gauge	1
13	14760102102101	Oil Gauge Gasket	1
14	00510000400801	Dowel Pin 4×8	1
15	14760102003001	Ventilation Nozzle	1
16	14760102001001	Lower Crankcase	1
17	00204000501641	Screw M5×16	2
18	00204000504041	Screw M5×40	4
19	14760102002101	Rubber One-Way Valve	1
20	14760501000001	One-Way Valve Components	1
21	14760103003011	Dual-Head Bolts M6×36	4
22	00031000601212	Hexagon Flange Bolt M6×12	1
23	14760103002031	Aluminium Gasket 6×13×2	1
24	14760103001001	Oil Pan	1
25	14620103100002	Oil Level Sensor	1
26	00252000601811	Screw M6×18	2

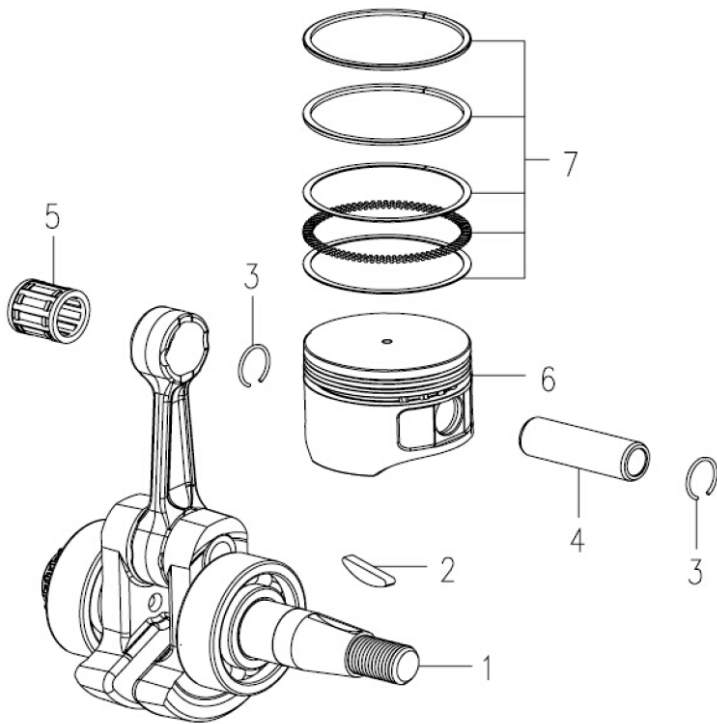

FIG B. CRANKSHAFT PISTON

No.	Part No.	Description	Qty
1	14760302000001	Connecting Rod	1
2	11310300010001	Woodruff Key	1
3	14760300001002	Piston Pin Clip	2
4	14760300002002	Piston Pin	1
5	00833710141402	Needle Bearing K101414	1
6	14810301001001	Piston	1
7	14780301006001	Piston Ring	1

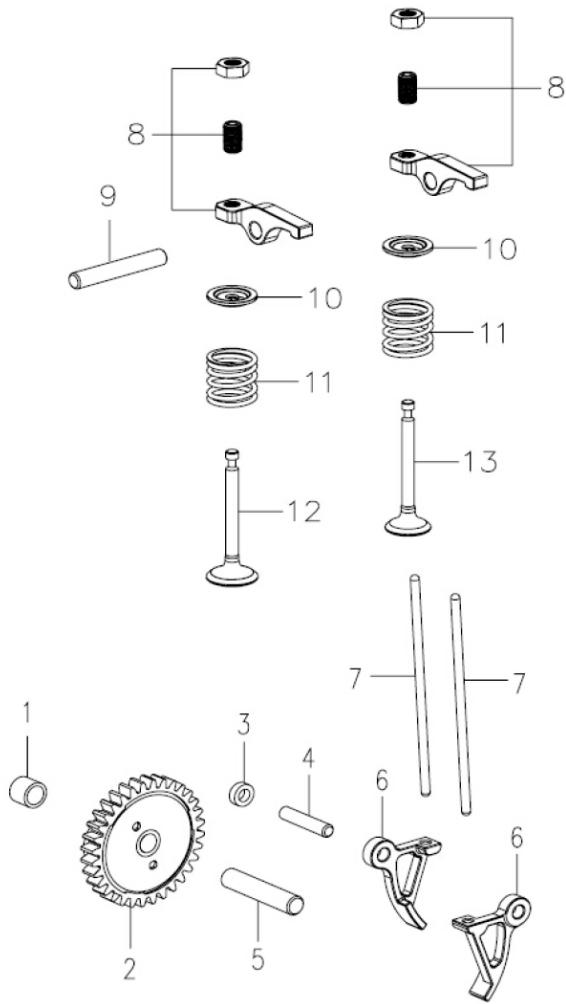

FIG C. CAMSHAFT

No.	Part No.	Description	Qty
1	14760100006001	Dowel Bush	1
2	14760401100012	Camshaft	1
	14760401001002	Decompression of the pin	1
	14760401002102	Torsional spring	1
	14760401003002	Cover for cam	1
3	14760400010041	Rocker Gasket	1
4	00504000402003	Pin4 g4×20	1
5	00504000603003	Pin4 g6×30	1
6	14760400006002	Lower Rocker	2
7	14760400009002	Tappet	2
8	14760400005002	Upper Rocker	2
9	00504000503203	Pin 5 g6×32	1
10	14760400003002	Valve Spring Seat	2
11	14760400004002	Valve Spring	2
12	14760400001003	Intake Valve	1
13	14760400002003	Exhaust Valve	1

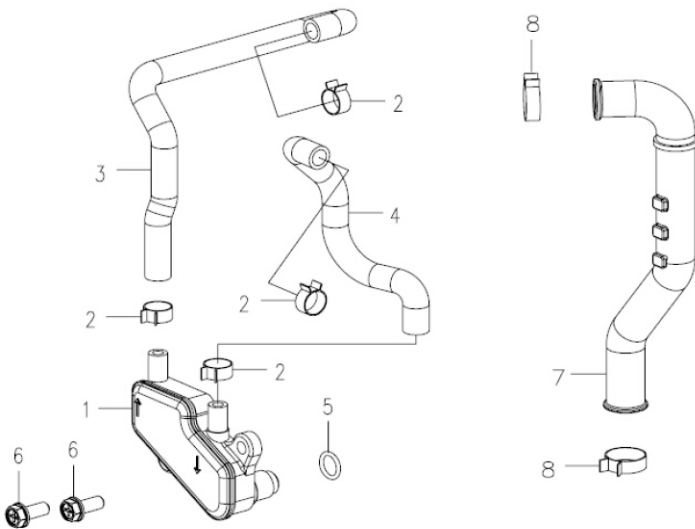

FIG D. LUBRICATION SYSTEM

No.	Part No.	Description	Qty
1	14760502000101	Deaerator	1
2	14760500005001	Pipe Hoop 9	4
3	14610500002001	Respiratory Tube	1
4	14610500003001	Outlet Tube	1
5	14760500004003	O Ring	1
6	00031000501612	Hexagon Flange Bolt M5×16	2
7	14610500001001	Upper Oil Pipe	1
8	11311600006002	Pipe Hoop 13	2

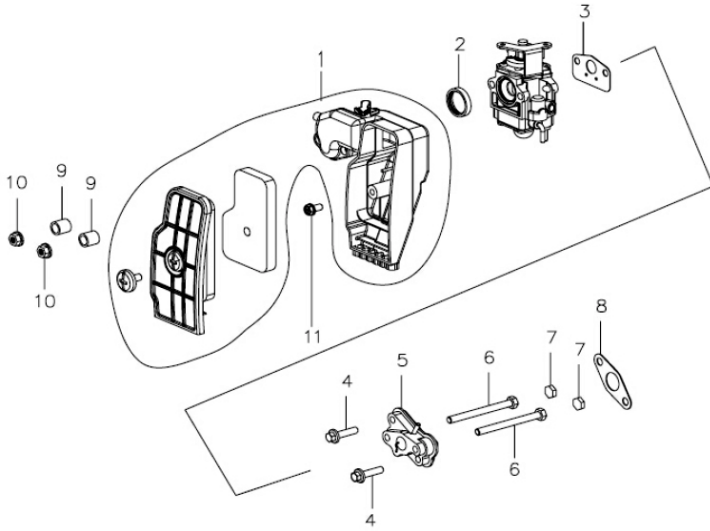

FIG E. AIR CLEANER

No.	Part No.	Description	Qty
1	14760801000002	Air Filter	1
	14760801003002	Foam	1
	14760801007021	big head chrome plated Screw	1
2	14760800004001	Gasket of Air Filter	1
3	14780800003002	Gasket of Carburator	1
4	00033000502211	Hexagon Flange Bolts M5×22	2
5	14810800002001	Insulation Board Components	1
6	00026000505551	Hexagon Flange Bolts M5×55	2
7	14810800003001	Block rubber	2
8	14810800001012	Insulation Board Gasket	1
9	15561100004002	Fan Volute Bush	2
10	00129000500011	Hexagon Flange Bolts M5	2
11	00427014801641	Tap Screw ST4.8×16-F.H	1

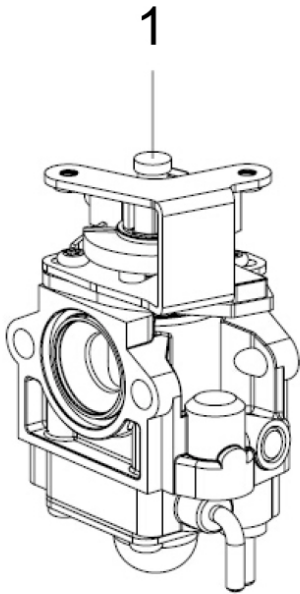

FIG.F CARBURETOR

No.	Part No.	Description	Qty
1	14760901000001	Carburator	1

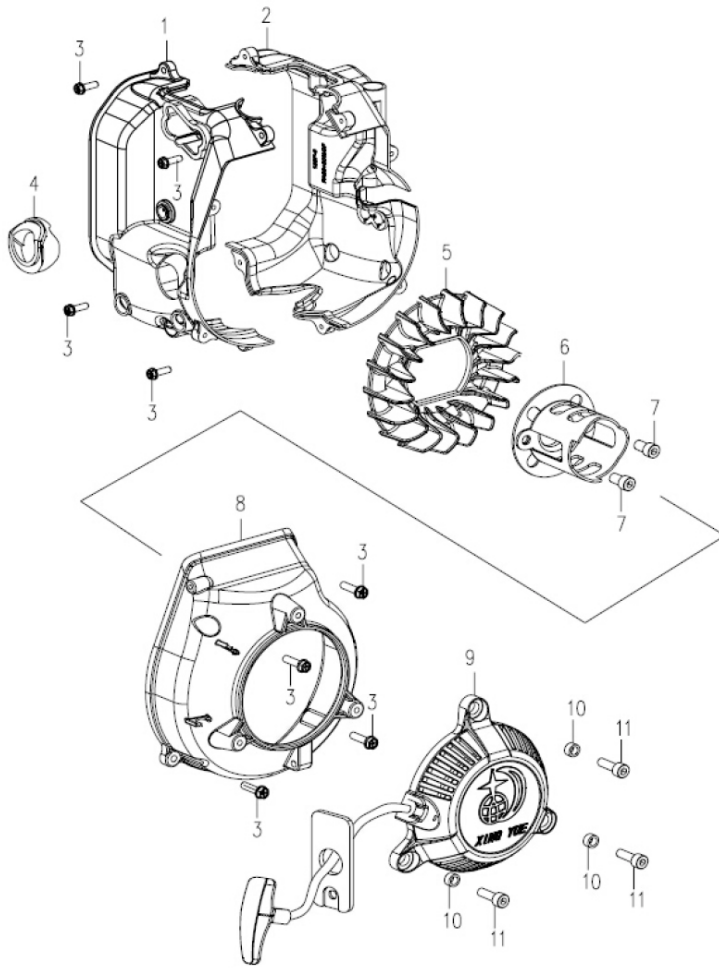

FIG G. RECOIL STARTER

No.	Part No.	Description	Qty
1	14811100001001	Air Guide Sleeve A	1
2	14761100014001	Air Guide Sleeve B	1
3	00427014801641	Tap Screw ST4.8×16	8
4	14611100006002	Oil Filler Hole Airproof Pad	1
5	14761100001002	Cooling Fan	1
6	14760602000001	Starting Hub	1
7	00204000601041	Inner Hexagon Screw M6×10	2
8	14761100002002	Fan Volute	1
9	14760601000002	Recoil Starter	1
	15560602001101	Handle	1
	15560602003001	Fender	1
10	15600600002003	Recoil Starter Bush	3
11	00031000501611	Hexagon Flange Bolts M5×16	3

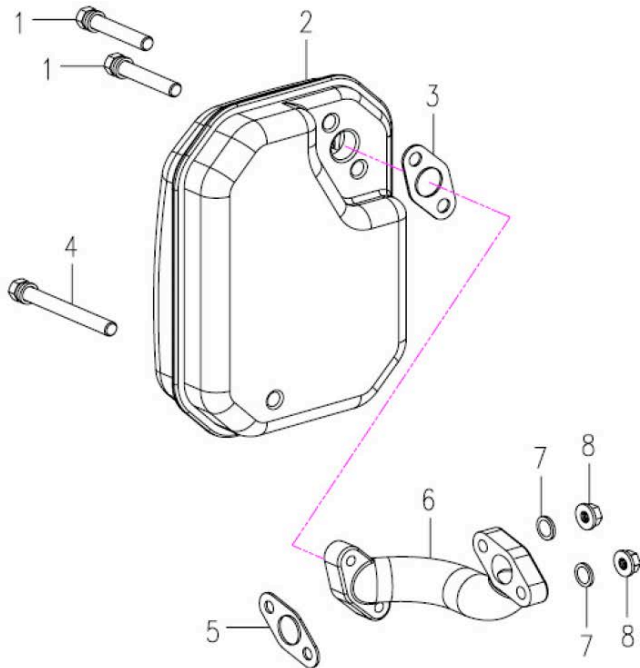

FIG H. MUFFLER

No.	Part No.	Description	Qty
1	00722000603511	Bolt M6×35	2
2	14760701000001	Muffler	1
3	14760700001011	Muffler Pipe Gasket	1
4	00722000605511	Bolt M6×55	1
5	14760700003011	Muffler Gasket	1
6	14760700002003	Muffler Pipe	1
7	00030000500041	Washer 5	2
8	00101000500011	Hexagon Flange Nut M5	2

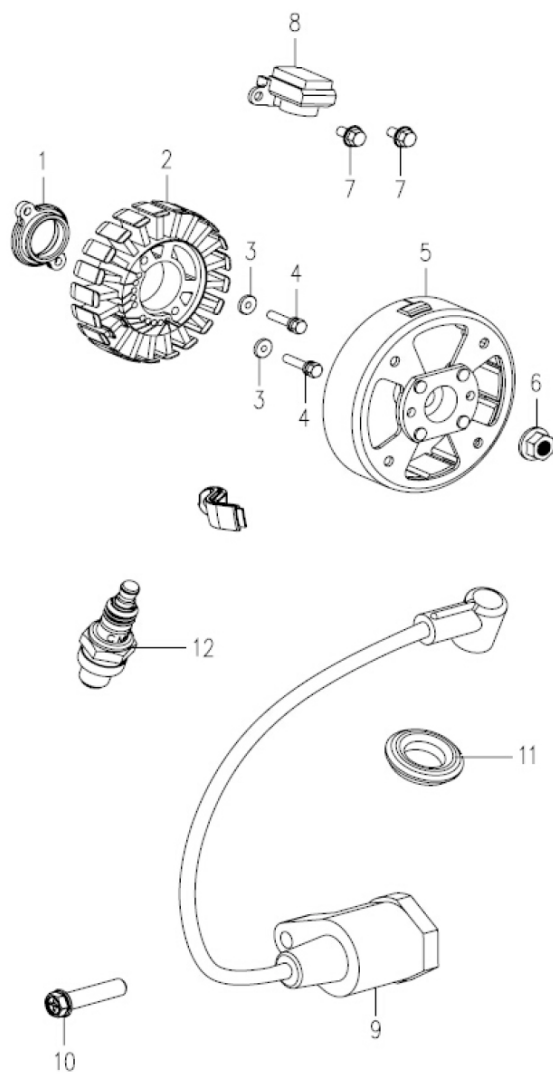

FIG I. GENERATOR

No.	Part No.	Description	Qty
1	14761000001001	Locating Plate	1
2	14761001101101	Stator 0.8KW 230V 580Hz	1
	14761000002002	Bushing	1
3	00030000500041	Washer 5	1
4	00033000502211	Hexagon Flange Bolts M5×35	2
5	14761001200101	Rotor	1
6	00129001000032	Hexagon Flange Nut M10×1.25	1
7	00033000501001	Hexagon Flange Bolts M5×10	2
8	14761000004002	Trigger	1
9	14761003000101	Ignition Coil	1
10	00241004802541	Tap Screw ST4.8×25-F.H	1
11	14761000003001	Ignition Coil Cap Seal	1
12	14761002000001	Spark Plug CMR6A	1

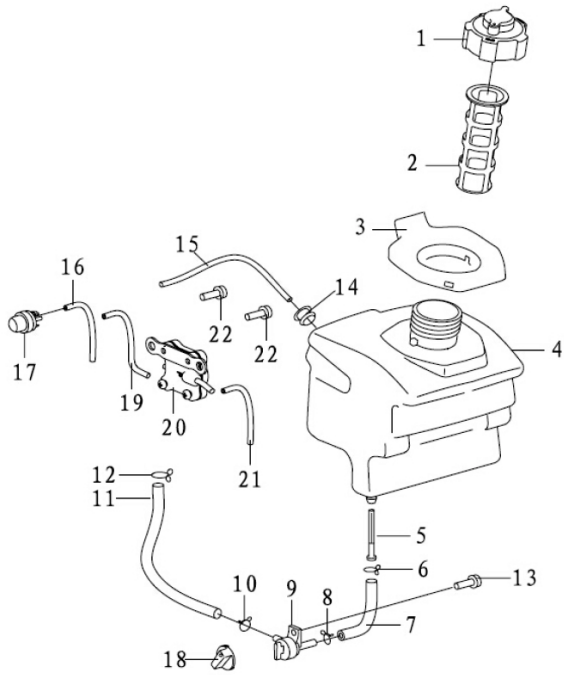
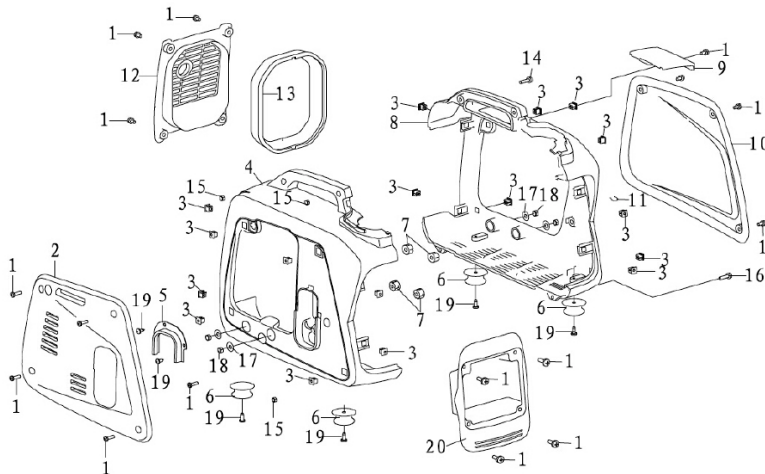

FIG J. FUEL TANK(EPA)

No.	Part No.	Description	Qty
1	462405010000	Fuel Tank Cap Assy.	1
2	462405020000	Fuel Tank Filter	1
3	460703000080	Fuel Tank Port Rubber	1
4	460705010011	Fuel Tank (EPA)	1
5	462405030000	Fuel Outlet Filter	1
6	480202020110	Steel Wire Clamp \varnothing 11	1
7	460705000011	Fuel Hose(EPA)	1
8	480202020100	Steel Wire Clamp \varnothing 10	1
9	460705020000	Fuel Cock	1
10	480202010090	Steel Wire Clamp \varnothing 9	1
11	460705000021	Fuel Hose 4.5×7.5×180(EPA)	1
12	480202010080	Steel Wire Clamp \varnothing 8	1
13	004210148013	Tap Screw GB/T845 ST4.8×13-F	1
14	460705010020	Fuel-hole Plug	1
15	480201250511	Fuel Hose 2.5×5×120(EPA)	1
16	480201250511	Fuel Hose 2.5×5×80(EPA)	1
17	460705040000	Fuel Lubricator	1
18	460705010040	Fuel Cock Knob	1
19	480201250511	Fuel Hose 2.5×5×95(EPA)	1
20	460705050000	negative pressure pump	1
21	480201250511	Fuel Hose 2.5×5×110(EPA)	1
22	004210348095	Tap Screw GB/T845 ST4.8×9.5-F	2

FIG K. SHELL

No.	Part No.	Description	Qty
1	004210148013	Screw 4.8×13-F	18
2	460703000050	Right Side Cover	1
3	460703000110	Fastener	17
4	460703000040	Right Cover of Shell	1
5	460703000061	Edge Protection	1
6	460703000140	Vibration Absorber	4
7	460703000120	Rubber Pad Φ 6× Φ 16×10	4
8	460703000010	Left Cover of Shell	1
9	460703000030	Upper Cover	1
10	460703000020	Left Side Cover	1
11	461503000080	Clamp	1
12	460703000090	Muffler Cover	1
13	460703000100	Muffler Cover Seal	1
14	007090005018	Screw GB/T9074.4 M5×18	2
15	001200005001	Hexagon Nut M5	4
16	002260005016	Cross Pan Head Screw M5×16	2
17	460703000130	Rubber Pad Φ 6.5× Φ 16×2	4
18	001410006001	Lock Nut GB/T6187 M6	4
19	004210348095	Tap Screw GB/T845 ST4.8×9.5-F	6
20	460703000070	Panel Box	1



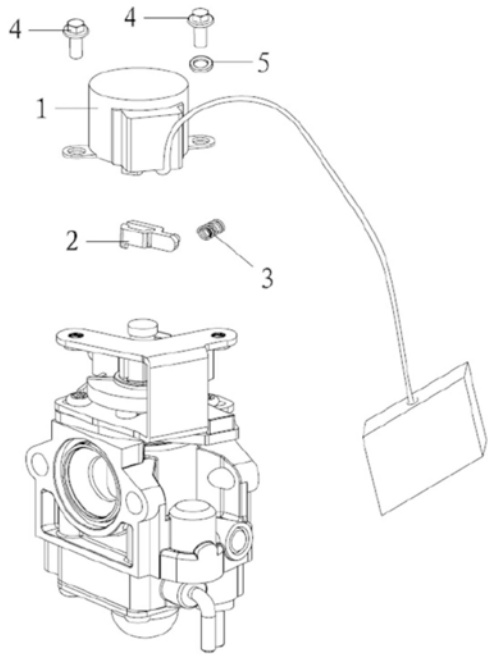

FIG L. GOVERNOR

No.	Part No.	Description	Qty
1	460720020000	Stepper Motor	1
2	155609000020	Drive Arm	1
3	155609000010	Drive Arm Spring	1
4	007080004006	Screw M4×6	2
5	003000004001	Spring Washer 4	1

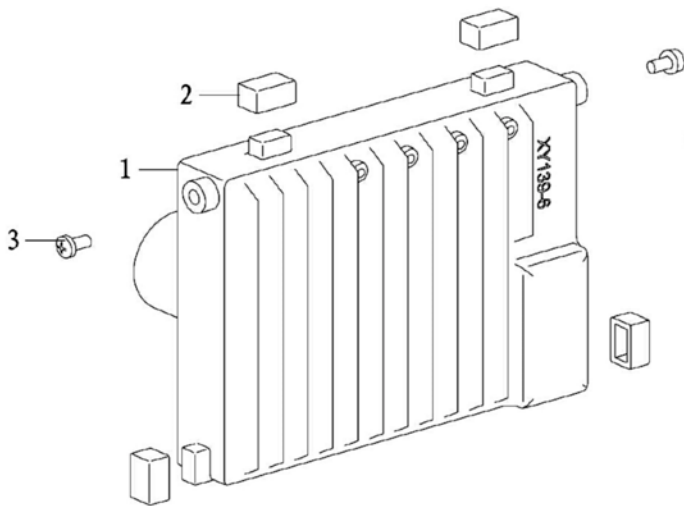

FIG M. INVERTER

No.	Part No.	Description	Qty
1	460719010000	Inverter 0.8Kw 120V~60Hz	1
	460719010000	Inverter 0.8Kw 100V~50/60Hz	1
2	460719000010	Inverter Gasket	4
3	007090005012	Screw GB/T9074.4 M5×12	2

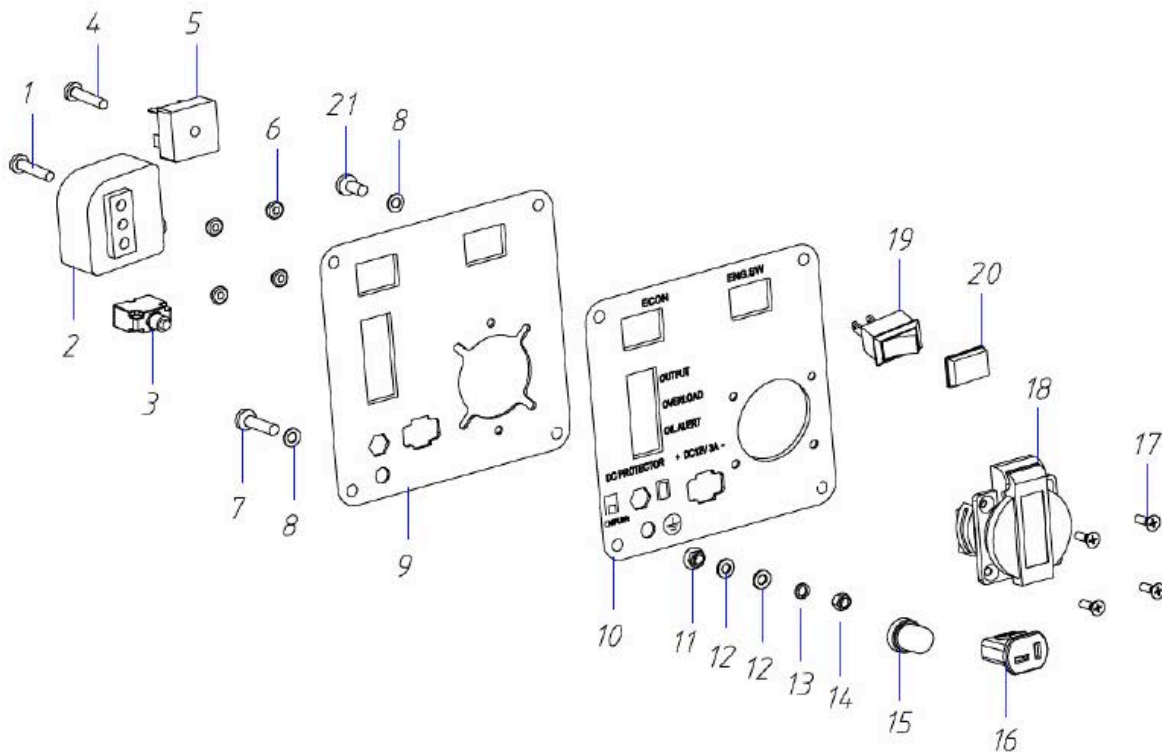

FIG N. CONTROL PANEL (FOR USA)

No.	Part No.	Description	Qty
1	007090005016	Cross Pan Head Screw M5×16	1
2	462417016000	Ignition Control Module	1
3	480107881450	Overload Protector 4.5A	1
4	007080005016	Cross Pan Head Screw M5×16	1
5	480110350200	Rectifier KBPC3502	1
6	001280004001	Hexagon Flange Nut M4	4
7	000330005016	Flange Bolt GB/16674 M5×16	1
8	003210005001	Lock Gasket GB862.2 φ5	3
9	460717011000	Panel Components	1
10	460788000030	Panel Sticker	1
11	001280005001	Flange Nut GB/T6177 M5	1
12	003020005001	Flat Washer GB/T97 φ5	2
13	003000005001	Spring Washer GB/T93 φ5	1
14	001200005001	Hexagon Nut GB/T6170 M5	1
15	480107000020	Water-Proof Cap of Protector	1
16	480101090030	DC Charging Socket	1
17	002210004012	Countersunk Head Screw M4×12	4
18	480101020040	American Socket 5-15R	1
19	480105010010	Boat Switch	2
20	480105090010	Water-Proof Cap of Boat Switch	2
21	007090005008	Screw M5×8	2
	460717010000	Control panel	1