Tool Cart Safety Warnings

1. Do not ride or climb on Cart. Keep away from children.
2. Do not exceed 300 lb. capacity, evenly distributed.

Be aware of dynamic loading!

Sudden load movement may briefly create excess load causing product failure.

3. Use only on a flat, level surface able to support Cart and load.
4. Wear ANSI-approved safety goggles during assembly.
5. Inspect before every use; do not use if parts are loose or damaged.

Assembly Instructions

For additional information regarding the parts listed in the following pages, refer to the Assembly Diagram near the end of this manual. Unwrap and separate all parts on a clear work area.

Attaching Posts to Bottom Tray

Lay the Bottom Tray (2) (the tray with four sets of four holes on the bottom) on the floor and attach the Posts (7) to the outside corners of the tray using sixteen Bolts (9), Washers (11), and Lock Nuts (8).

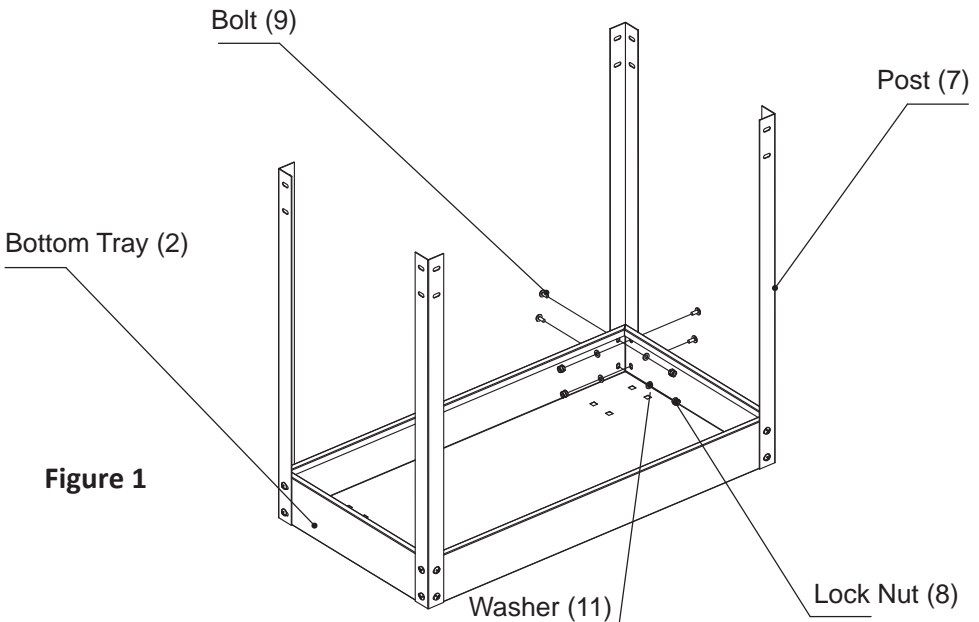
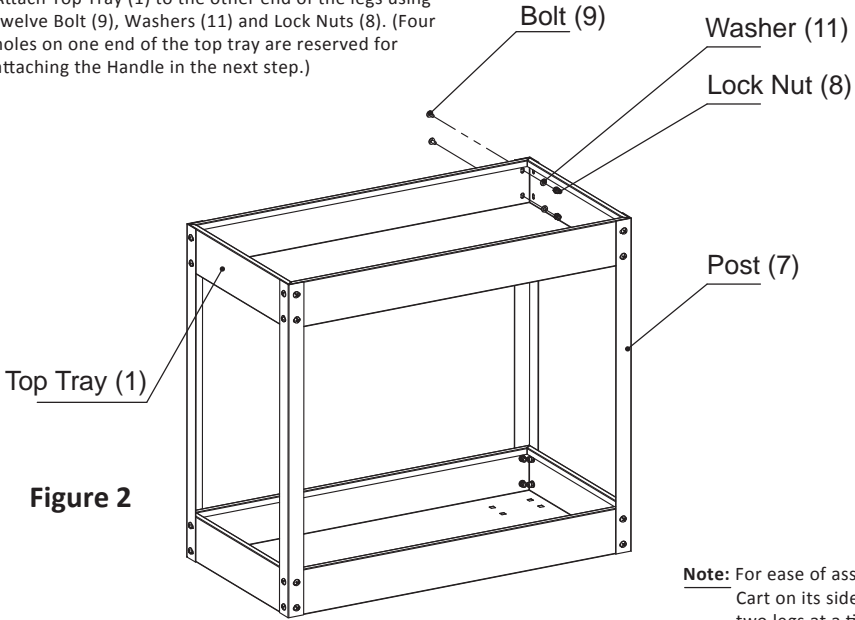

Figure 1

Attaching Top Tray

Attach Top Tray (1) to the other end of the legs using twelve Bolt (9), Washers (11) and Lock Nuts (8). (Four holes on one end of the top tray are reserved for attaching the Handle in the next step.)



Attaching Handle

Assemble the Pipe Plug (6) onto ends of Handle (4) and attach Handle (4) to end of Posts (7) using four Bolts (10), Washers (11) and Lock Nuts (8).

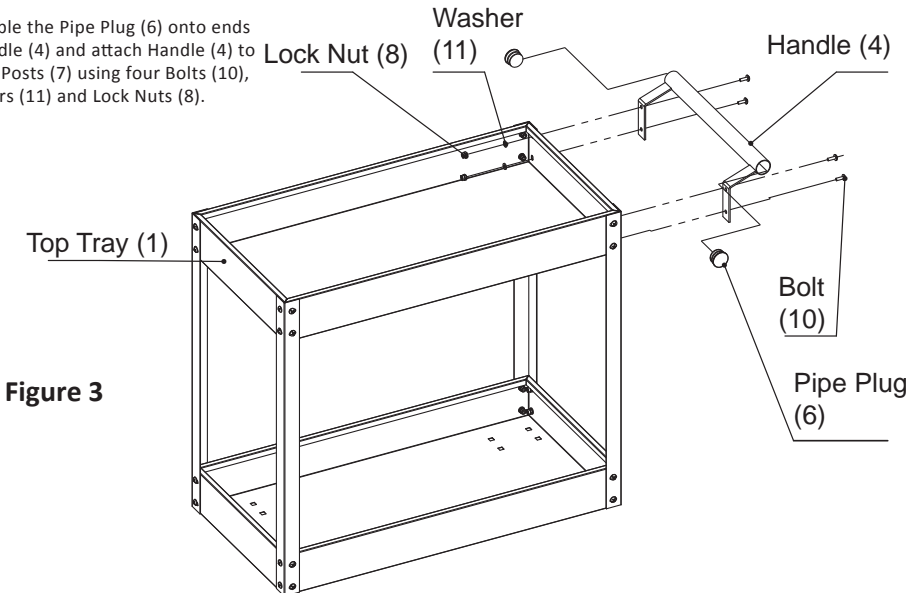

Assembly Instructions (Continued)

Attaching Wheels

1. Decide on which end of the Cart to mount the pair of Rigid Wheels (5) and pair of Swivel wheels (3). For example, mounting the Fixed Wheels on the Handle end of the Cart will make a push Cart like those in a grocery store.
2. Attach each Fixed Wheel to one end of the Bottom Tray (2) using four Bolts (12), Washers (13) and Lock Nuts (14).
3. Attach each Swivel Wheel (3) to the remaining end of the Bottom Tray (2) using the remaining Bolts (12), Washers (13) and Lock Nuts (14).

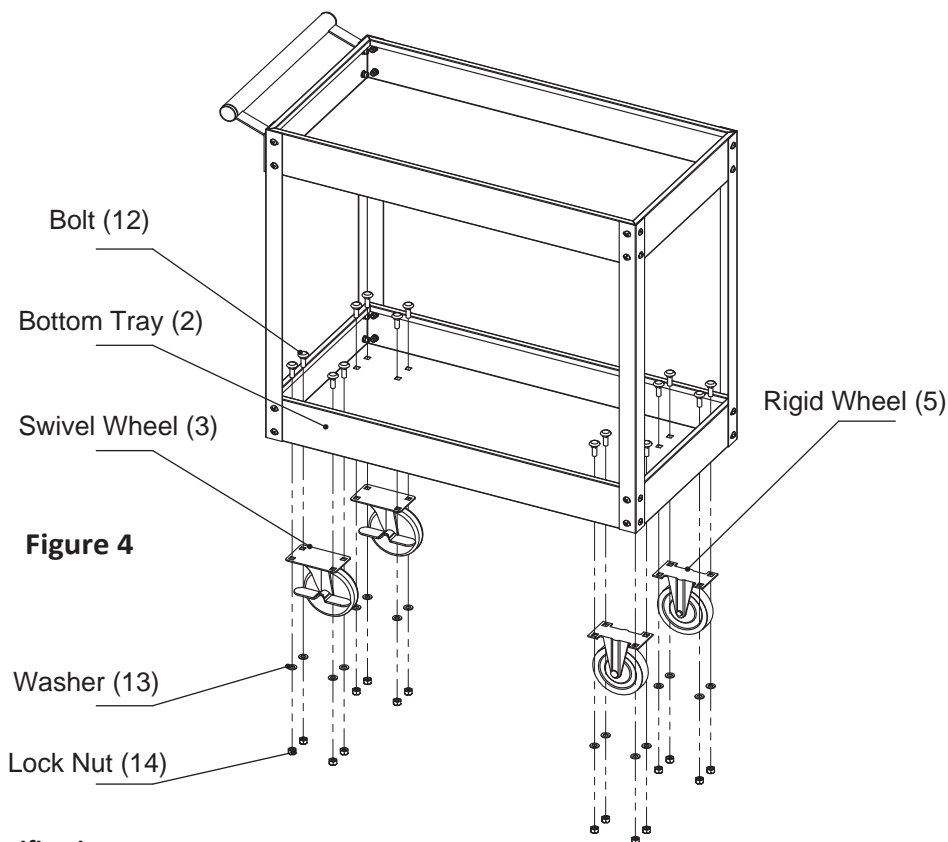

Specifications

Total Capacity	300Lb
Tray Depth	3-1/2"
Wheels	4" Rubber Casters (two fixed and two locking swivel)
Dimensions	29" L x 15" W x 33-1/4" H

Parts List and Assembly Diagram

Part	Description	Q'ty
1	Top Tray	1
2	Bottom Tray	1
3	Swivel Wheel	2
4	Handle	1
5	Rigid Wheel	2
6	Pipe Plug $\varnothing 32$	2
7	Post	4

Part	Description	Q'ty
8	Looknut M6	32
9	Bolt M6 x 12	28
10	Bolt M6 x 16	4
11	Washer $\varnothing 6$	32
12	Carriage Bolt Screw M8 x 16	16
13	Washer $\varnothing 8$	16
14	Looknut M8	16

