

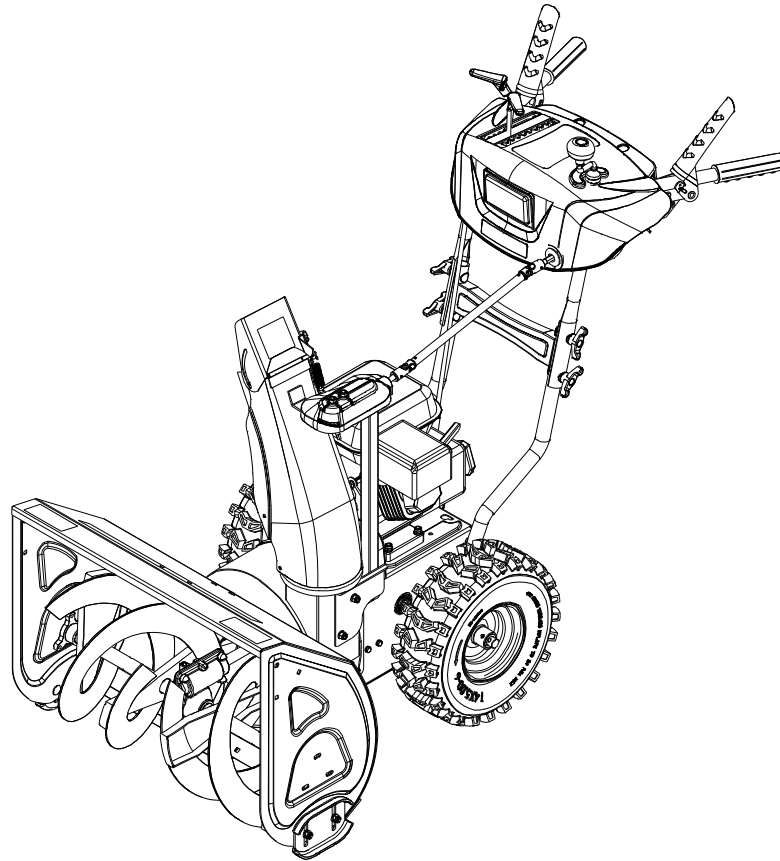

# Parts Manual



## Dual Stage Snow Thrower

### Snowthrowers

Mfg. No.	Description
1696614-01	1024MD, B&S 9.5 Gross TP 24" Dual Stage Snowthrower (2017)

Manual Part No. 1760684

Revision -

Rev. Date: 7/5/2016

Not for  
Reproduction

<b>PRODUCT COMPONENTS</b>	<b>PAGES</b>
Handles & Controls Group .....	4
Engine & Frame Group .....	10
Auger Housing Group .....	14
Auger Drive Group .....	16
Wheels & Tires Group .....	20
Decals Group .....	22
Discharge Chute Group .....	24
Transaxle Drive Group .....	28
<b>Torque Specification Chart .....</b>	<b>Inside Back Cover</b>

Not for  
Reproduction

## Handles & Controls Group

NOTE: Unless noted otherwise,  
use the standard hardware torque  
specification chart.

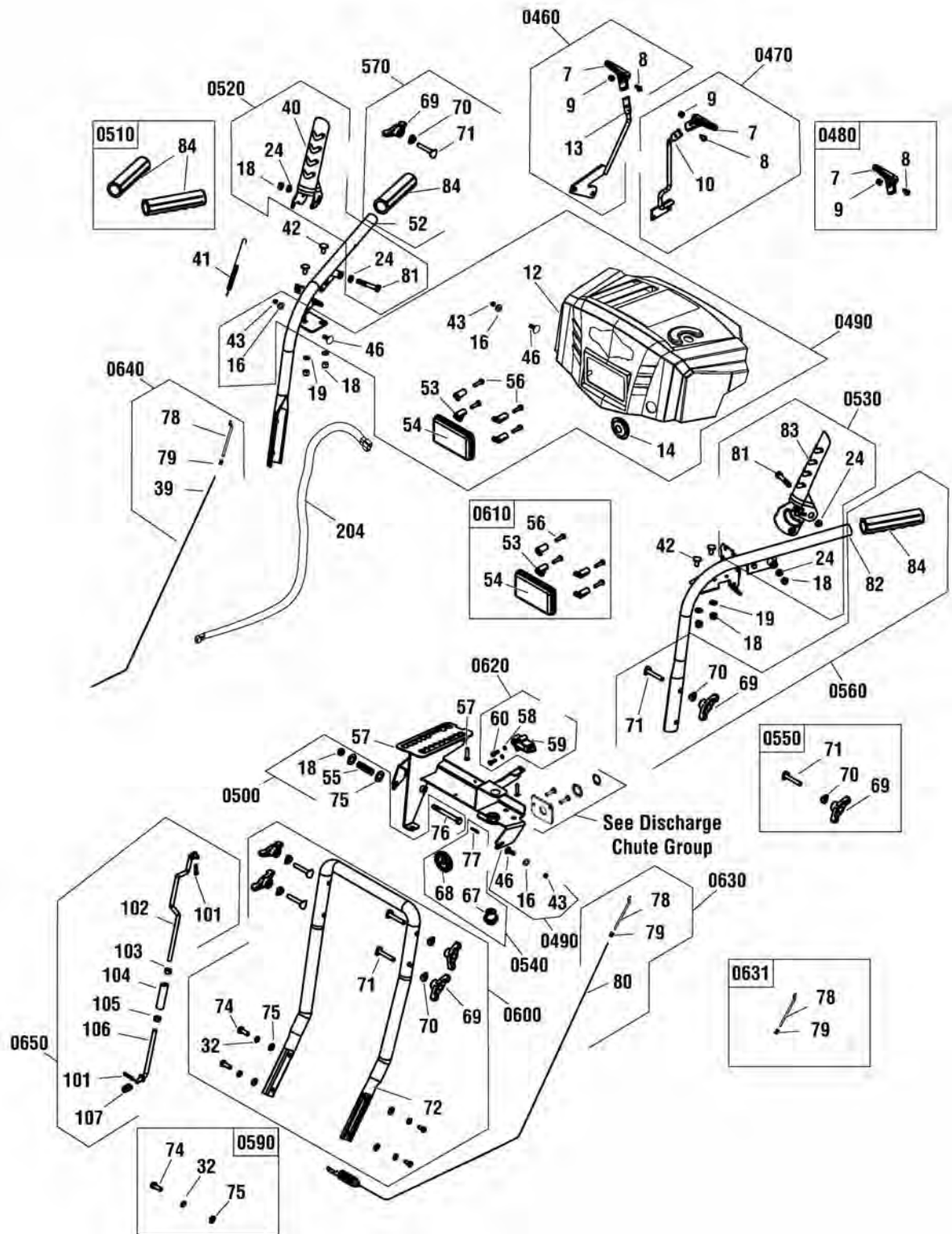

The above parts group applies to the following Mfg. Nos.:  
1696614-01 - 1024MD

## Handles & Controls Group

REF NO	PART NO.	QTY.	DESCRIPTION
0460	770081	1	KIT, Lever, Speed (Incl. Ref. Nos. 7, 8, 9 & 13)
7	-----	1	*KNOB (Included with Ref. No. 0460)
8	-----	1	*BOLT, Phillips Head (Included with Ref. No. 0460)
9	-----	1	*NUT, Hex Head Lock, Non-metal (Included with Ref. No. 0460)
13	-----	1	*LEVER, Control, Drive Speed (Included with Ref. No. 0460)
0470	707505	1	KIT, Lever, Discharge Chute (Incl. Ref. Nos. 7, 8, 9 & 10)
7	-----	1	*KNOB (Included with Ref. No. 0470)
8	-----	1	*BOLT, Phillips Head (Included with Ref. No. 0470)
9	-----	1	*NUT, Hex Head Lock, Non-metal (Included with Ref. No. 0470)
10	-----	1	*LEVER, Control, Discharge Chute (Included with Ref. No. 0470)
0480	707504	1	KIT, Knob, Lever (Incl. Ref. Nos. 7, 8 & 9)
7	-----	1	*KNOB (Included with Ref. No. 0480)
8	-----	1	*BOLT, Phillips Head (Included with Ref. No. 0480)
9	-----	1	*NUT, Hex Head Lock, Non-metal (Included with Ref. No. 0480)
0490	770072	1	KIT, Dash (Incl. Ref. Nos. 12, 14, 16, 43, 46, 53, 54, 56, 301, 302, 312, 313 & 314)
12	-----	1	*PANEL, Dash (Included with Ref. No. 0490)
14	-----	1	*SLEEVE, Rubber (Included with Ref. No. 0490)
16	-----	2	*WASHER, Flat (Included with Ref. No. 0490)
43	-----	2	*NUT, Hex Head Lock, Non-metal (Included with Ref. No. 0490)
46	-----	2	*BOLT, Square Neck, Cup Head (Included with Ref. No. 0490)
53	-----	4	*BUCKLE, Lamp (Included with Ref. No. 0490)
54	-----	1	*LAMP (Included with Ref. No. 0490)
56	-----	6	*BOLT, Phillips Head (Included with Ref. No. 0490)
301	1751429YP	1	DECAL, Auger Control (Included with Ref. No. 0490)
302	1751430YP	1	DECAL, Traction Control (Included with Ref. No. 0490)
312	-----	1	*DECAL, 1-6 Transmission Speed Control (Included with Ref. No. 0490)
313	-----	1	*DECAL, Free Hand Operation (Included with Ref. No. 0490)
314	-----	1	*DECAL, Chute Rotation (Included with Ref. No. 0490)
0500	707507	1	KIT, Hardware, Speed & Discharge (Incl. Ref. Nos. 18, 55, 75 & 76)
18	-----	1	*NUT, Hex Head Lock, Non-metal (Included with Ref. No. 0500)
55	-----	1	*SPRING (Included with Ref. No. 0500)
75	-----	2	*WASHER, Flat (Included with Ref. No. 0500)
76	-----	1	*SCREW, Hex Head (Included with Ref. No. 0500)
0510	770080	1	KIT, Grip, Handle (Incl. Qty. 2 Ref. No. 84)
84	-----	2	Grip (Included with Ref. No. 0510)
0520	707509	1	KIT, Right Hand Lever, Traction Drive (Incl. Ref. Nos. 18, 24, 40 & 81)
18	-----	2	*NUT, Hex Head Lock, Non-metal (Included with Ref. No. 0520)
24	-----	1	*PAD, Small Tensioning Plate (Included with Ref. No. 0520)
40	-----	1	*LEVER, Traction Drive Engagement Lever (Included with Ref. No. 0520)
81	-----	1	*SCREW, Hex Head (Included with Ref. No. 0520)

### Footnotes

Note:\* Not a serviceable part.

The above parts group applies to the following Mfg. Nos.:

1696614-01 - 1024MD

## Handles & Controls Group

NOTE: Unless noted otherwise,  
use the standard hardware torque  
specification chart.

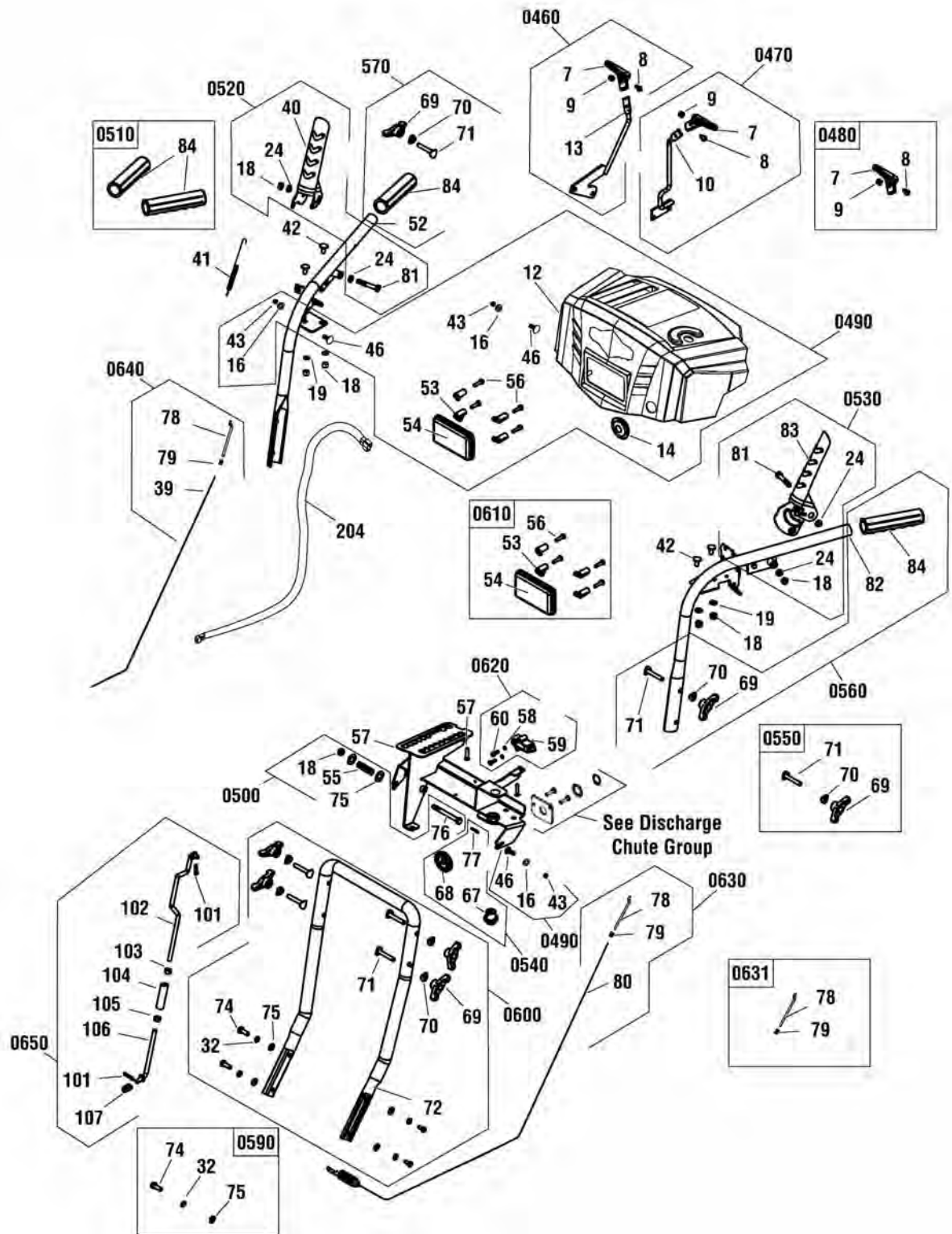

The above parts group applies to the following Mfg. Nos.:  
1696614-01 - 1024MD

## Handles & Controls Group

REF NO	PART NO.	QTY.	DESCRIPTION
0530	707508	1	KIT, Left Hand Lever, Auger Drive (Incl. Ref. Nos. 18, 24, 81 & 83)
18	-----	1	*NUT, Hex Head Lock, Non-metal (Included with Ref. No. 0530)
24	-----	2	*PAD, Small Tensioning Plate (Included with Ref. No. 0530)
81	-----	1	*SCREW, Hex Head (Included with Ref. No. 0530)
83	-----	1	*LEVER, Auger Engagement (Included with Ref. No. 0530)
0540	770070	1	KIT, Bevel Gear, Chute Rotation (Incl. Ref. Nos. 68, 68 & 77)
67	-----	1	*GEAR, Bevel (Included with Ref. No. 0540)
68	-----	1	*GEAR, Bevel, Turning (Included with Ref. No. 0540)
77	-----	1	*PIN, Spring (Included with Ref. No. 0540)
0550	707513	1	KIT, Wing Knob, Handle (Incl. Ref. Nos. 69, 70 & 71)
69	-----	2	*KNOB, Handle (Included with Ref. No. 0550)
70	-----	2	*WASHER (Included with Ref. No. 0550)
71	-----	2	*BOLT (Included with Ref. No. 0550)
0560	770075	1	KIT, Upper Handle, Left (Incl. Ref. Nos. 69, 70, 71, 82 & 84)
69	-----	2	*KNOB, Handle (Included with Ref. No. 0560)
70	-----	2	*WASHER (Included with Ref. No. 0560)
71	-----	2	*BOLT (Included with Ref. No. 0560)
82	-----	1	*HANDLE, Upper, Left (Included with Ref. No. 0560)
84	-----	1	*GRIP (Included with Ref. No. 0560)
0570	770076	1	KIT, Upper Handle, Right (Incl. Ref. Nos. 52, 69, 70, 71, & 84)
52	-----	1	*HANDLE, Upper, Right (Included with Ref. No. 0570)
69	-----	2	*KNOB, Handle (Included with Ref. No. 0570)
70	-----	2	*WASHER (Included with Ref. No. 0570)
71	-----	2	*BOLT (Included with Ref. No. 0570)
84	-----	1	*GRIP (Included with Ref. No. 0570)
0590	707517	1	KIT, Lower Handle Hardware (Included with Ref. No. 0570)
32	-----	4	*WASHER (Incl. Ref. Nos. 32, 74 & 75)
74	-----	4	*SCREW, Hex Head (Included with Ref. No. 0590)
75	-----	4	*WASHER, Flat (Included with Ref. No. 0590)
0600	707518	1	KIT, Lower Handle (Incl. Ref. Nos. 32, 69, 70, 71, 72, 74 & 75)
32	-----	4	*WASHER (Included with Ref. No. 0600)
69	-----	4	*KNOB, Handle (Included with Ref. No. 0600)
70	-----	4	*WASHER (Included with Ref. No. 0600)
71	-----	4	*BOLT (Included with Ref. No. 0600)
72	-----	1	*HANDLE, Lower (Included with Ref. No. 0600)
74	-----	4	*SCREW, Hex Head (Included with Ref. No. 0600)
75	-----	4	*WASHER, Flat (Included with Ref. No. 0600)
0610	707519	1	KIT, Headlight (Incl. Ref. Nos. 32, 69, 70, 71, 72, 74 & 75)
53	-----	4	*BUCKLE, Lamp (Included with Ref. No. 0610)
54	-----	1	*LAMP (Included with Ref. No. 0610)
56	-----	4	*BOLT, Phillips Head (Included with Ref. No. 0610)
41	707877	1	SPRING, Handle

### Footnotes

Note:\* Not a serviceable part.

The above parts group applies to the following Mfg. Nos.:

1696614-01 - 1024MD

## Handles & Controls Group

NOTE: Unless noted otherwise,  
use the standard hardware torque  
specification chart.

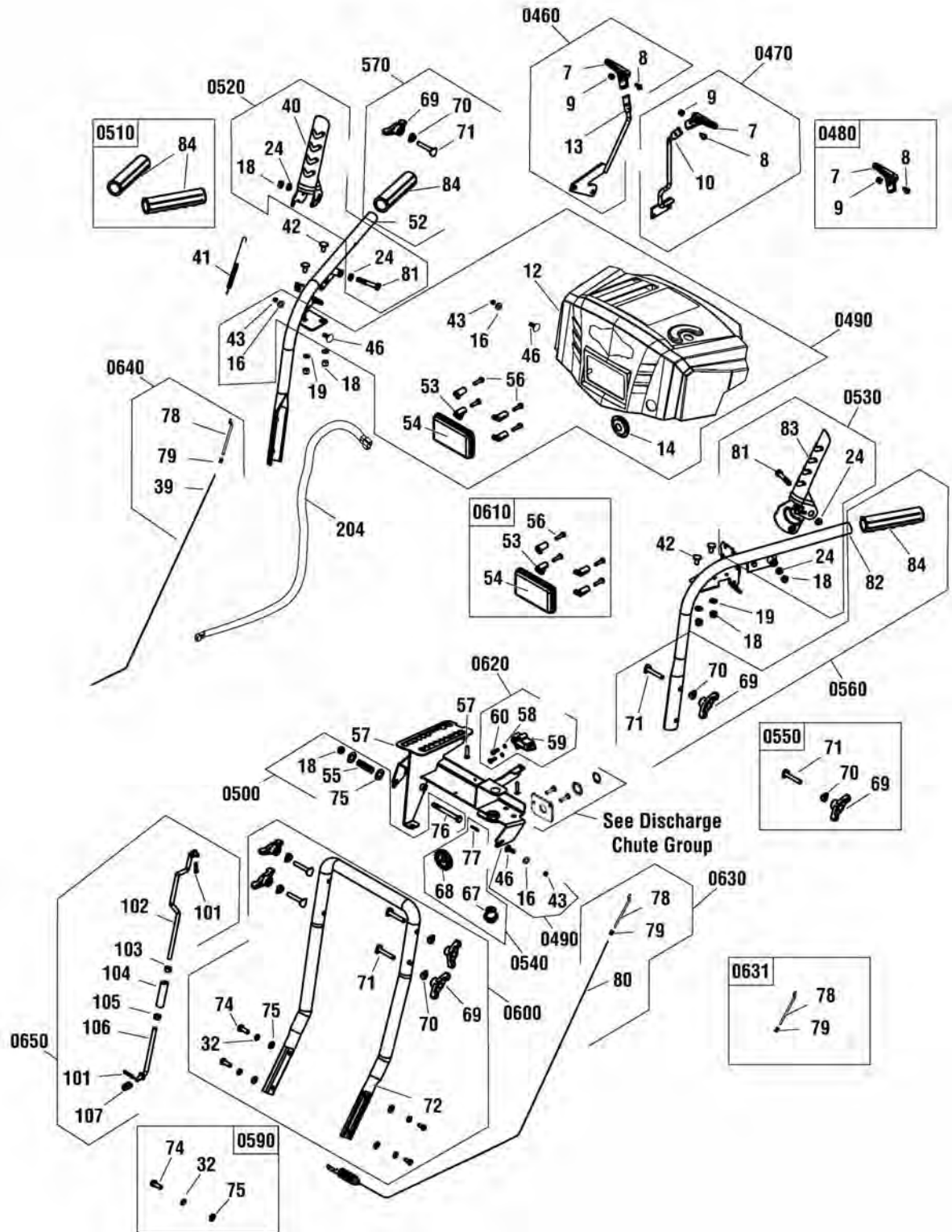

The above parts group applies to the following Mfg. Nos.:  
1696614-01 - 1024MD



## Handles & Controls Group

REF NO	PART NO.	QTY.	DESCRIPTION
0620	707521	1	KIT, Free Hand Control Assembly (Incl. Ref. Nos. 58, 59 & 60)
58	-----	2	*WASHER, Spring (Included with Ref. No. 0620)
59	-----	1	*SELF-LOCK, Assembly (Included with Ref. No. 0620)
60	-----	2	*SCREW, Hex Head (Included with Ref. No. 0620)
0630	707760	1	KIT, Cable, Auger Clutch (Incl. Ref. Nos. 78, 79 & 80)
78	-----	1	*ROD, Steel (Included with Ref. No. 0630)
79	-----	1	*NUT, Copper (Included with Ref. No. 0630)
80	-----	1	*CABLE, Auger (Included with Ref. No. 0630)
0631	709758	1	KIT, Cable, Hardware (Incl. Ref. Nos. 78 & 79)
78	-----	1	*ROD, Steel (Included with Ref. No. 0631)
79	-----	1	*NUT, Copper (Included with Ref. No. 0631)
0640	707761	1	KIT, Cable, Traction Drive (Incl. Ref. Nos. 39, 78 & 79)
39	-----	1	*ROD, Steel (Included with Ref. No. 0640)
78	-----	1	*ROD, Steel (Included with Ref. No. 0640)
79	-----	1	*NUT, Copper (Included with Ref. No. 0640)
0650	707526	1	KIT, Transaction Drive Rod (Incl. Ref. Nos. 101, 102, 103, 104, 105, 106 & 107)
101	-----	2	*BOLT (Included with Ref. No. 0650)
102	-----	1	*ROD, Traction Drive (Included with Ref. No. 0650)
103	-----	1	*SCREW, Hex Head (Included with Ref. No. 0650)
104	-----	1	*ROD, Regulating Sleeve, Drive (Included with Ref. No. 0650)
105	-----	1	*NUT (Included with Ref. No. 0650)
106	-----	1	*ROD, Traction Drive (Included with Ref. No. 0650)
107	-----	1	*SPRING, Regulating (Included with Ref. No. 0650)
57	-----	1	*PANEL, Steel
18	-----	4	*NUT, Hex Head Lock, Non-metal
19	-----	4	*WASHER, Flat
42	-----	4	*BOLT, Square Neck Cup Head
204	707637	1	HARNESS, Wiring

### Footnotes

Note:\* Not a serviceable part.

The above parts group applies to the following Mfg. Nos.:

1696614-01 - 1024MD

## Engine & Frame Group

NOTE: Unless noted otherwise,  
use the standard hardware torque  
specification chart.

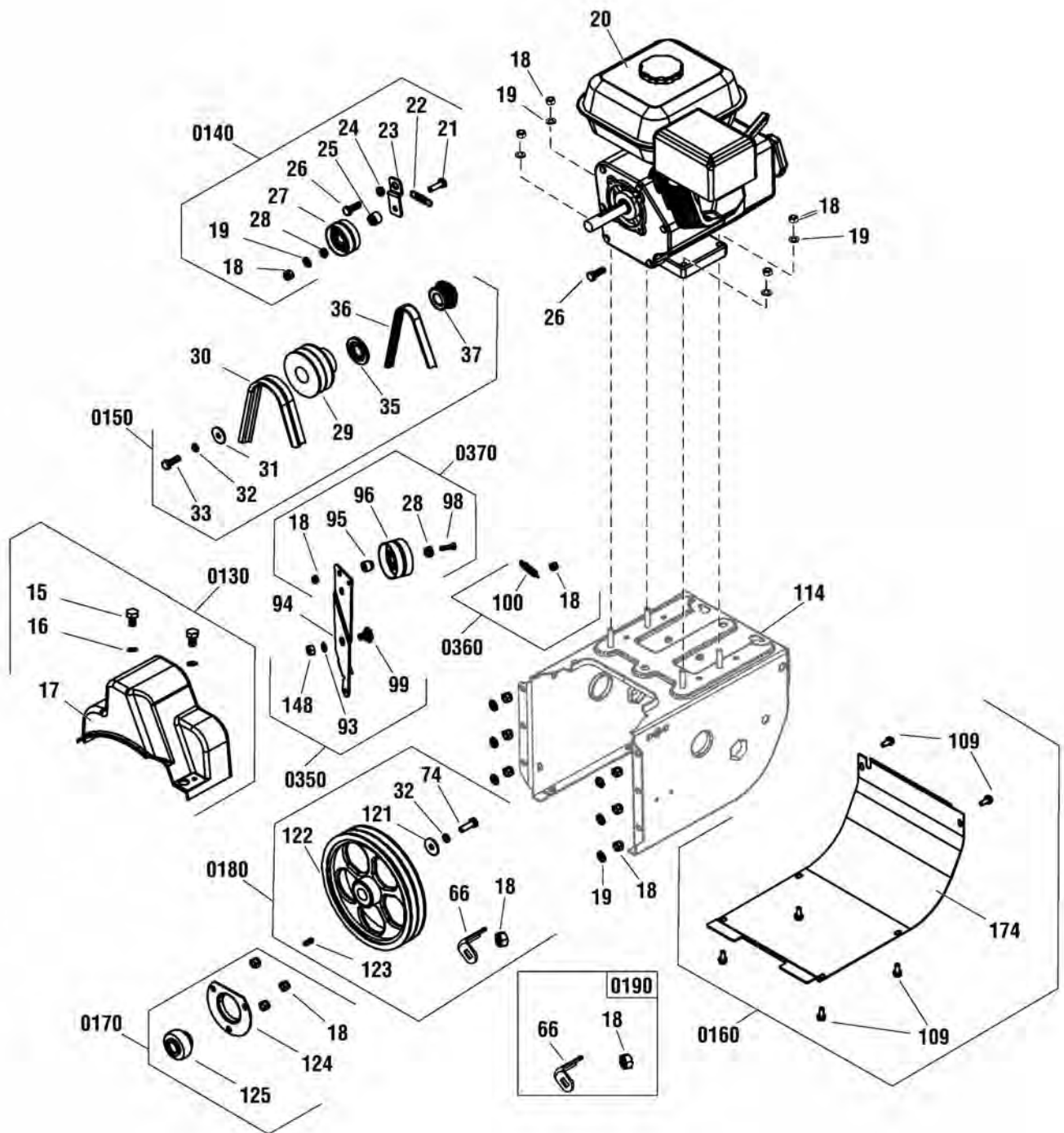

The above parts group applies to the following Mfg. Nos.:  
1696614-01 - 1024MD

## Engine & Frame Group

REF NO	PART NO.	QTY.	DESCRIPTION
20	13A137-0004-F1	1	**ENGINE, 9.5 Gross TP Briggs & Stratton (Engine Model: 13A137-0004-F1)
18	-----	4	*NUT, Hex Head Lock, Non-metal
19	-----	4	*WASHER, Flat
26	-----	1	*SCREW, Hex Head
0130	707567	1	KIT, Belt Cover (Incl. Ref. Nos. 15, 16 & 17)
15	-----	2	*SCREW, Hex Head (Included with Ref. No. 0130)
16	-----	2	*WASHER, Flat (Included with Ref. No. 0130)
17	-----	1	*COVER, Belt (Included with Ref. No. 0130)
0140	707568	1	KIT, Idler Pulley, Traction Drive (Incl. Ref. Nos. 18, 19, 21, 22, 23, 24, 25, 26, 27 & 28)
18	-----	1	*NUT, Hex Head Lock, Non-metal (Included with Ref. No. 0140)
19	-----	1	*WASHER, Flat (Included with Ref. No. 0140)
21	-----	1	*SCREW, Hex Head (Included with Ref. No. 0140)
22	-----	1	*SPRING (Included with Ref. No. 0140)
23	-----	1	*PLATE, Tensioning, Small (Included with Ref. No. 0140)
24	-----	1	*PAD, Tensioning Plate, Small (Included with Ref. No. 0140)
25	-----	1	*PAD, Tensioning Wheel, Small (Included with Ref. No. 0140)
26	-----	1	*SCREW, Hex Head (Included with Ref. No. 0140)
27	-----	1	*WHEEL, Tensioning Assembly, Small (Included with Ref. No. 0140)
28	-----	1	*Washer (Included with Ref. No. 0140)
30	707584	2	BELT, Auger Drive
36	707585	1	BELT, Traction Drive
0150	770141	1	KIT, Engine Pulley (Incl. Ref. Nos. 29, 31, 32, 33, 35 & 37)
29	-----	1	*PULLEY, Impeller Drive (Included with Ref. No. 0150)
31	-----	1	*WASHER, Flat (Included with Ref. No. 0150)
32	-----	1	*WASHER, Spring (Included with Ref. No. 0150)
33	-----	1	*SCREW, Hex Head (Included with Ref. No. 0150)
35	-----	1	*RING, Retainer, Synch-pulley (Included with Ref. No. 0150)
37	-----	1	*SYNCH-PULLEY (Included with Ref. No. 0150)
0160	707542	1	KIT, Bottom Cover (Incl. Ref. Nos. 109 & 174)
109	-----	6	*SCREW, Hex Head (Included with Ref. No. 0160)
174	-----	1	*COVER, Motor Box, Lower (Included with Ref. No. 0160)
0170	707548	1	KIT, Bearing Hardware, Auger Pulley (Incl. Ref. Nos. 18, 124 & 125)
18	-----	3	*NUT, Hex Head Lock, Non-metal (Included with Ref. No. 0170)
124	-----	1	*COVER, Round Bottom (Included with Ref. No. 0170)
125	-----	1	*BEARING, Ball (Included with Ref. No. 0170)
114	-----	1	*BOX, Frame
0180	707743	1	KIT, Auger Pulley (Incl. Ref. Nos. 18, 32, 66, 74, 121, 122 & 123)
18	-----	1	*NUT, Hex Head Lock, Non-metal (Included with Ref. No. 0180)
32	-----	1	*WASHER, Spring (Included with Ref. No. 0180)
66	-----	1	*BAFFLE, Belt (Included with Ref. No. 0180)
74	-----	1	*SCREW, Hex Head (Included with Ref. No. 0180)
121	-----	1	*WASHER, Flat (Included with Ref. No. 0180)
122	-----	1	*PULLEY, Drive (Included with Ref. No. 0180)

### Footnotes

Note\*\* To verify your specific engine model, please reference the ID Tag located on your engine. See your local Briggs & Stratton distributor for parts and service.

Note:\* Not a serviceable part.

**The above parts group applies to the following Mfg. Nos.:**

1696614-01 - 1024MD

## Engine & Frame Group

NOTE: Unless noted otherwise,  
use the standard hardware torque  
specification chart.

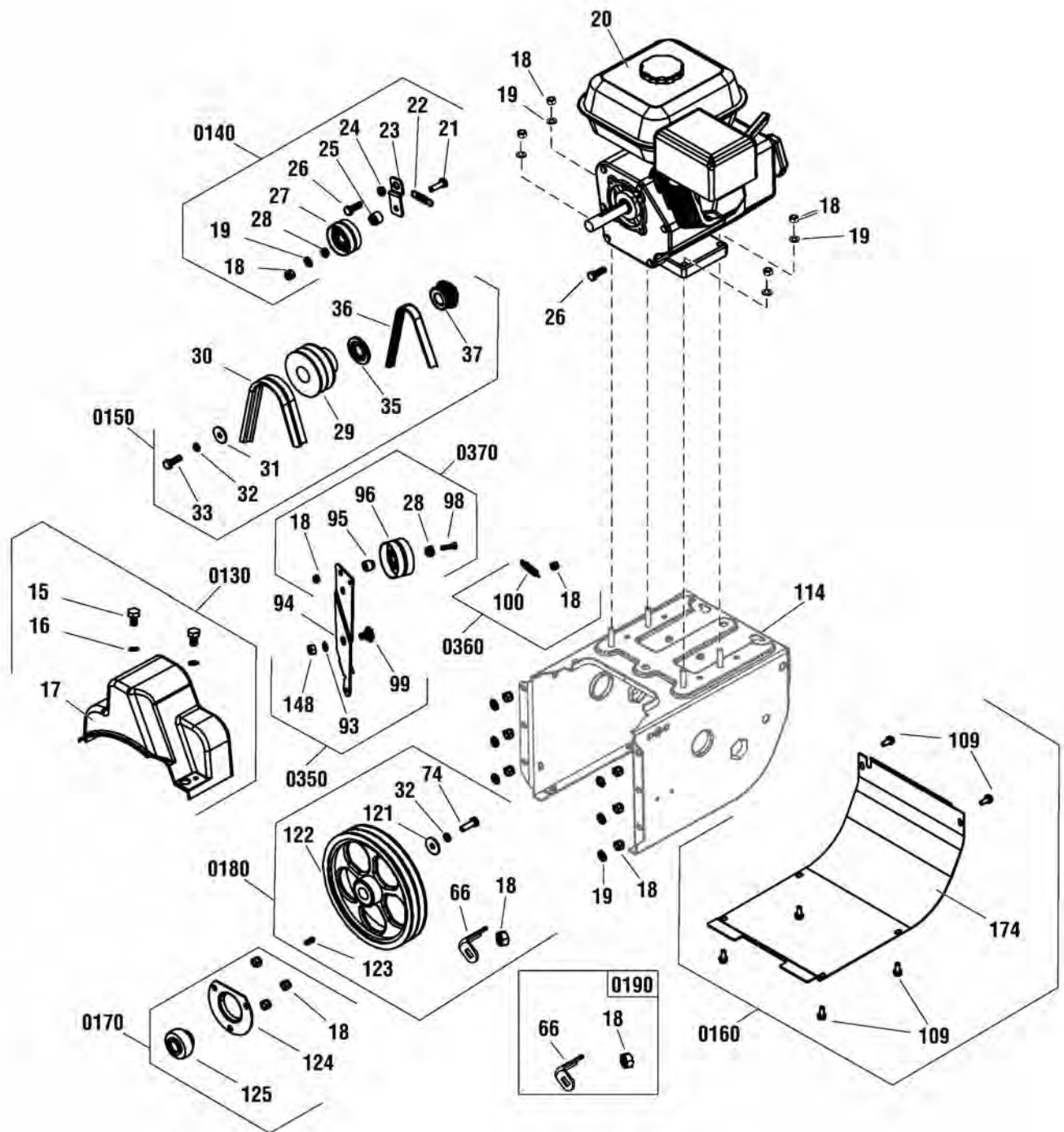

The above parts group applies to the following Mfg. Nos.:  
1696614-01 - 1024MD

## Engine & Frame Group

REF NO	PART NO.	QTY.	DESCRIPTION
123	----	1	*KEY, Flat (Included with Ref. No. 0180)
0190	707547	1	KIT, Belt Guide, Auger (Incl. Ref. Nos. 18 & 66)
18	----	1	*NUT, Hex Head Lock, Non-metal (Included with Ref. No. 0190)
66	----	1	*BAFFLE, Belt (Included with Ref. No. 0190)
0350	707565	1	KIT, Hardware, Idler Bracket (Incl. Ref. Nos. 93, 99 & 148)
93	----	1	*WASHER, Flat (Included with Ref. No. 0350)
99	----	1	*SCREW, Hex Head (Included with Ref. No. 0350)
148	----	1	*NUT, Hex Head Lock, Non-metal (Included with Ref. No. 0350)
94	709965	1	PLATE, Large Tensioning
0360	707654	1	KIT, Spring, Idler Pulley (Incl. Ref. Nos. 18 & 100)
18	----	1	*NUT, Hex Head Lock, Non-metal (Included with Ref. No. 0360)
100	----	1	*SPRING (Included with Ref. No. 0360)
0370	707566	1	KIT, Idler Pulley, Tension Plate (Incl. Ref. Nos. 18, 28, 95, 96 & 98)
18	----	1	*NUT, Hex Head Lock, Non-metal (Included with Ref. No. 0370)
28	----	1	*WASHER (Included with Ref. No. 0370)
95	----	1	*SLEEVE, Washer (Included with Ref. No. 0370)
96	----	1	*WHEEL, Large Tensioning (Included with Ref. No. 0370)
98	----	1	*SCREW, Hex Head (Included with Ref. No. 0370)

Not for  
Reproduction

### Footnotes

Note\*\* To verify your specific engine model, please reference the ID Tag located on your engine. See your local Briggs & Stratton distributor for parts and service.

Note:\* Not a serviceable part.

---

The above parts group applies to the following Mfg. Nos.:

1696614-01 - 1024MD

## Auger Housing Group

NOTE: Unless noted otherwise,  
use the standard hardware torque  
specification chart.

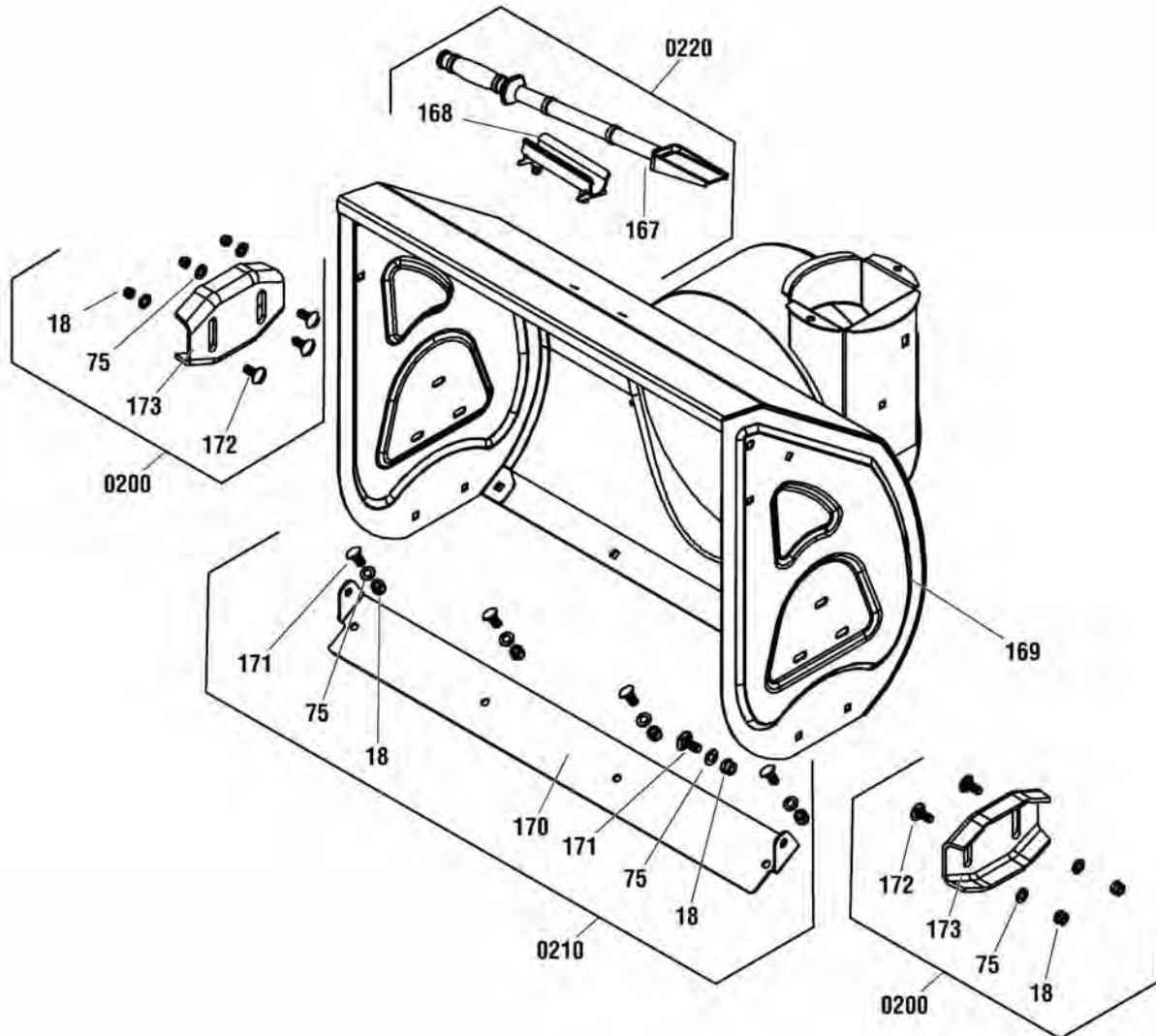

The above parts group applies to the following Mfg. Nos.:

1696614-01 - 1024MD

## Auger Housing Group

REF NO	PART NO.	QTY.	DESCRIPTION
169	-----		*HOUSING, Auger, 24"
0200	707550	1	KIT, Skid Shoe (Incl. Ref. Nos. 18, 75, 172 & 173)
18	-----	4	*NUT, Hex Head Lock, Non-metal (Included with Ref. No. 0200)
75	-----	4	*WASHER, Flat (Included with Ref. No. 0200)
172	-----	4	*BOLT, Square Neck, Cup Head (Included with Ref. No. 0200)
173	-----	2	*SHOE, Skid (Included with Ref. No. 0200)
0210	707762	1	KIT, Scraper Bar (Incl. Ref. Nos. 18, 75, 170 & 171)
18	-----	6	*NUT, Hex Head Lock, Non-metal (Included with Ref. No. 0210)
75	-----	6	*WASHER, Flat (Included with Ref. No. 0210)
170	-----	1	*BAR, Scraper, 24" Housing (Included with Ref. No. 0210)
171	-----	6	*BOLT, Square Neck, Cup Head (Included with Ref. No. 0210)
0220	707549	1	KIT, Cleanout Brush Stick (Incl. Ref. Nos. 167 & 168)
167	-----	1	*STICK, Cleanout (Included with Ref. No. 0220)
168	-----	1	*BASE, Cleanout Stick (Included with Ref. No. 0220)

Not for  
Reproduction

### Footnotes

Note:\* Not a serviceable part.

---

The above parts group applies to the following Mfg. Nos.:

1696614-01 - 1024MD

# Auger Drive Group

NOTE: Unless noted otherwise,  
use the standard hardware torque  
specification chart.

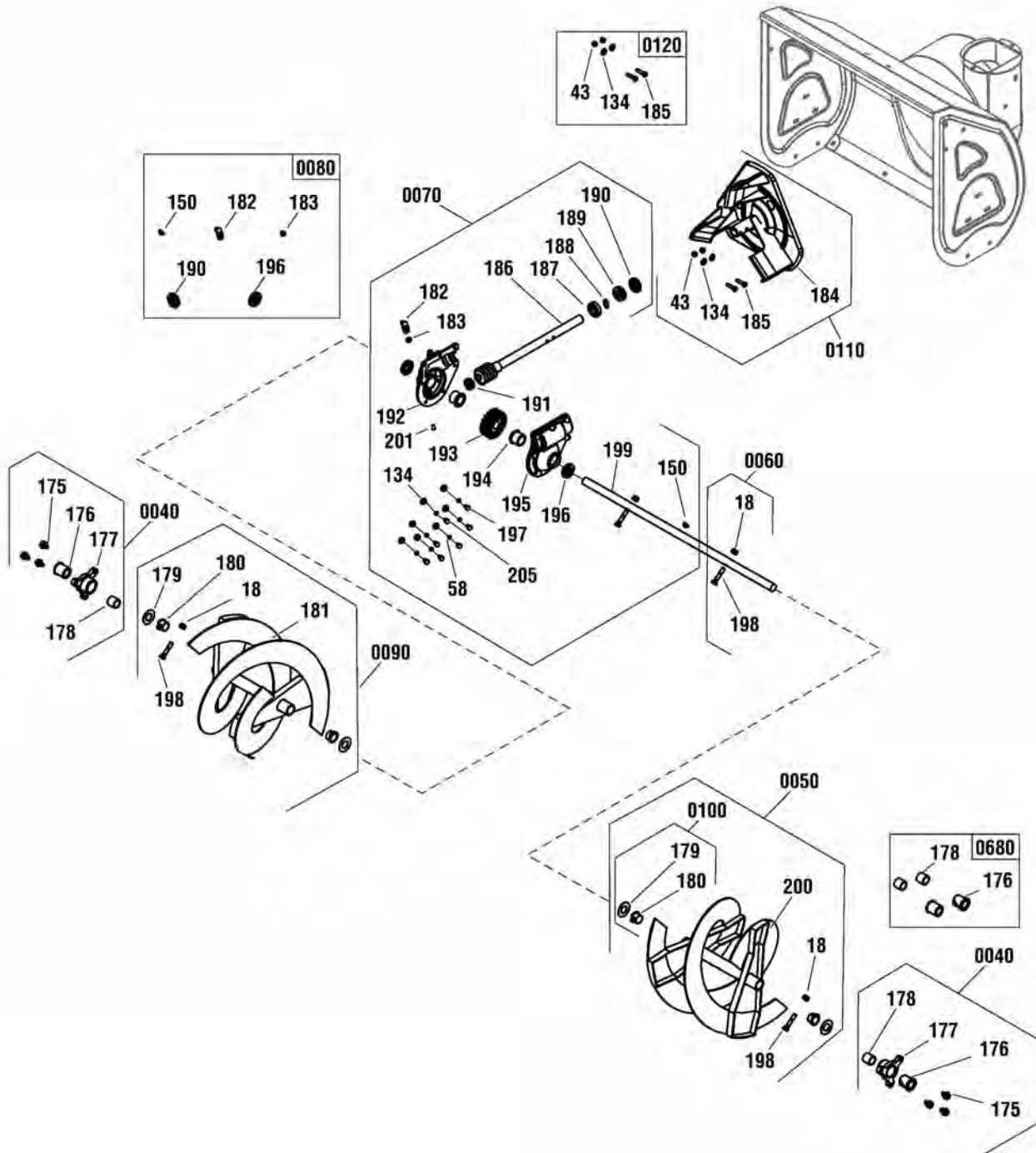

The above parts group applies to the following Mfg. Nos.:  
1696614-01 - 1024MD



## Auger Drive Group

REF NO	PART NO.	QTY.	DESCRIPTION
0040	707553	2	KIT, Mounting Plate, Auger Housing (Incl. Ref. Nos. 175, 176, 177 & 178)
175	-----	3	*SCREW, Hex Head (Included with Ref. No. 0040)
176	-----	1	*BEARING, Nylon (Included with Ref. No. 0040)
177	-----	1	*BASE, Auger (Included with Ref. No. 0040)
178	-----	1	*PAD, Auger (Included with Ref. No. 0040)
0050	707744	1	KIT, Auger Assembly, Left (Incl. Ref. Nos. 18, 179, 180, 198 & 200)
18	-----	2	*NUT, Hex Head Lock, Non-metal (Included with Ref. No. 0050)
179	-----	2	*WASHER, Flat (Included with Ref. No. 0050)
180	-----	2	*SLEEVE, Output Shaft 24-2 (Included with Ref. No. 0050)
198	-----	2	*BOLT, Auger Shear (Included with Ref. No. 0050)
200	-----	1	*AUGER, Left (Included with Ref. No. 0050)
0060	707555	1	Kit, Shear Pin, Auger (Incl. Ref. Nos. 18 & 198)
18	-----	2	*NUT, Hex Head Lock, Non-metal (Included with Ref. No. 0060)
198	-----	2	*BOLT, Auger Shear (Included with Ref. No. 0060)
0070	707745	1	KIT, Gear Box, Auger (Incl. Ref. Nos. 18, 75, 58, 134, 150, 182, 183, 185, 186, 187, 188, 189, 190, 191, 192, 193, 194, 195, 196, 197, 199, 201 & 205)
18	-----	2	*NUT, Hex Head Lock, Non-metal (Included with Ref. No. 0070)
75	-----	2	*WASHER, Flat (Included with Ref. No. 0070)
58	-----	7	*WASHER, Spring (Included with Ref. No. 0070)
134	-----	7	*WASHER, Flat (Included with Ref. No. 0070)
150	-----	2	*KEY, Woodruff (Included with Ref. No. 0070)
182	-----	1	*NIPPLE, Oil (Included with Ref. No. 0070)
183	-----	1	*GASKET, Corrugated (Included with Ref. No. 0070)
185	-----	2	*SCREW, Fixed, Impeller (Included with Ref. No. 0070)
186	-----	1	*SHAFT, Worm (Included with Ref. No. 0070)
187	-----	1	*BEARING, Deep Groove Ball (Included with Ref. No. 0070)
188	-----	1	*SPACER (Included with Ref. No. 0070)
189	-----	1	*BEARING, Single Thrust Ball (Included with Ref. No. 0070)
190	-----	1	*SEAL, Oil (Included with Ref. No. 0070)
191	-----	1	*BEARING, Deep Groove Ball (Included with Ref. No. 0070)
192	-----	1	*BOX, Gear, Right (Included with Ref. No. 0070)
193	-----	1	*GEAR, Worm (Included with Ref. No. 0070)
194	-----	2	*SLEEVE, Output Shaft (Included with Ref. No. 0070)
195	-----	1	*BOX, Gear, Left (Included with Ref. No. 0070)
196	-----	2	*SEAL, Oil (Included with Ref. No. 0070)
197	-----	6	*SCREW, Hex Head (Included with Ref. No. 0070)
199	-----	1	*SHAFT, Auger (Included with Ref. No. 0070)
201	-----	1	*BOLT, Phillips Head (Included with Ref. No. 0070)
205	-----	1	*SCREW, Hex Head (Included with Ref. No. 0070)
0080	707558	1	KIT, Seal, Gear Box (Incl. Ref. Nos. 150, 182, 183, 190 & 196)
182	-----	1	*NIPPLE, Oil (Included with Ref. No. 0080)
183	-----	1	*GASKET, Corrugated (Included with Ref. No. 0080)
196	-----	2	*SEAL, Oil (Included with Ref. No. 0080)

### Footnotes

Note:\* Not a serviceable part.

The above parts group applies to the following Mfg. Nos.:

1696614-01 - 1024MD

# Auger Drive Group

NOTE: Unless noted otherwise, use the standard hardware torque specification chart.

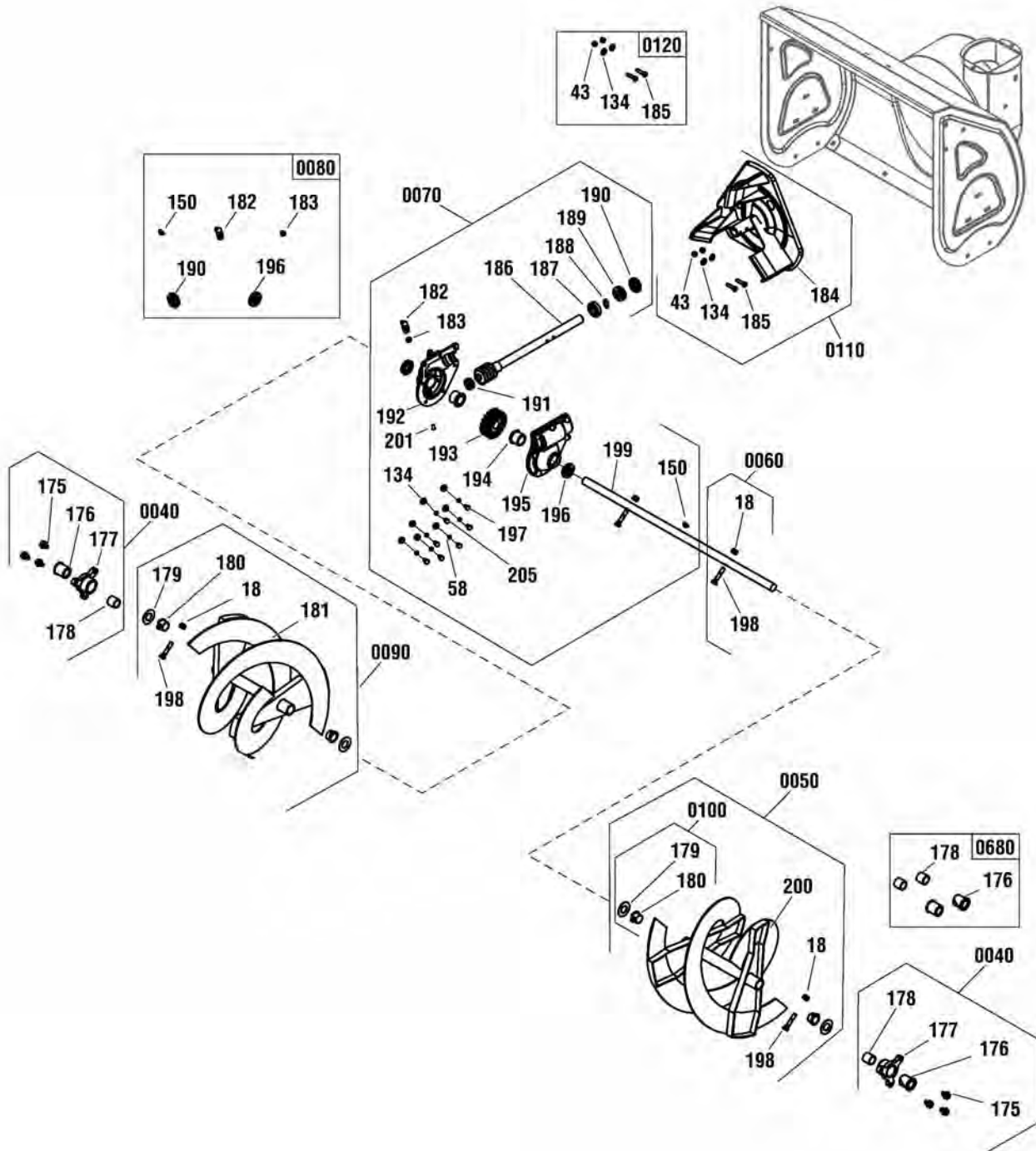

The above parts group applies to the following Mfg. Nos.:  
1696614-01 - 1024MD

## Auger Drive Group

REF NO	PART NO.	QTY.	DESCRIPTION
0090	707763	1	KIT, Auger Assembly, Right (Incl. Ref. Nos. 18, 179, 180, 181 & 198)
18	-----	2	*NUT, Hex Head Lock, Non-metal (Included with Ref. No. 0090)
179	-----	2	*WASHER, Flat (Included with Ref. No. 0090)
180	-----	2	*SLEEVE, Output Shaft 24-2 (Included with Ref. No. 0090)
181	-----	1	*AUGER, Right (Included with Ref. No. 0090)
198	-----	2	*BOLT, Auger Shear (Included with Ref. No. 0090)
0100	707554	1	KIT, Auger Shaft Hardware (Incl. Ref. Nos. 179 & 180)
179	-----	2	*WASHER, Flat (Included with Ref. No. 0100)
180	-----	2	*SLEEVE, Output Shaft 24-2 (Included with Ref. No. 0100)
0110	707560	1	KIT, Impeller Assembly (Incl. Ref. Nos. 43, 134, 184, & 185)
43	-----	2	*NUT, Hex Head Lock, Non-metal (Included with Ref. No. 0110)
134	-----	2	*WASHER, Flat (Included with Ref. No. 0110)
184	-----	1	*BLADE, Impeller (Included with Ref. No. 0110)
185	-----	2	*SCREW, Fixed, Impeller (Included with Ref. No. 0110)
0120	707561	1	KIT, Shear Pin, Impeller (Incl. Ref. Nos. 18, 134 & 185)
43	-----	2	*NUT, Hex Head Lock, Non-metal (Included with Ref. No. 0120)
134	-----	2	*WASHER, Flat (Included with Ref. No. 0120)
185	-----	2	*SCREW, Fixed, Impeller (Included with Ref. No. 0120)
0680	707552	1	KIT, Bearing, Mounting Plate (Incl. Ref. Nos. 176 & 178)
176	-----	2	*BEARING, Nylon (Included with Ref. No. 0680)
178	-----	2	*PAD, Auger (Included with Ref. No. 0680)

Not for  
Reproduction

### Footnotes

Note:\* Not a serviceable part.

The above parts group applies to the following Mfg. Nos.:

1696614-01 - 1024MD



## Wheels & Tires Group

REF NO	PART NO.	QTY.	DESCRIPTION
0010	707534	1	KIT, Wheel & Tire, Right (Incl. Ref. Nos. 34, 44, 97 & 156)
34	-----	1	*TIRE, Assembly, Right (Included with Ref. No. 0010)
44	-----	1	*WASHER, Flat (Included with Ref. No. 0010)
97	-----	1	*GASKET, Corrugated (Included with Ref. No. 0010)
156	-----	1	*PIN, Klik (Included with Ref. No. 0010)
0020	707533	1	KIT, Wheel & Tire, Left (Incl. Ref. Nos. 44, 97, 155 & 156)
44	-----	1	*WASHER, Flat (Included with Ref. No. 0020)
97	-----	1	*GASKET, Corrugated (Included with Ref. No. 0020)
155	-----	1	*TIRE, Assembly, Left (Included with Ref. No. 0020)
156	709530	1	*PIN, Klik (Included with Ref. No. 0020)
0030	770078	1	KIT, Axle & Sprocket (Incl. Ref. Nos. 44, 97, 149, 150, 151, 152, 153 & 154)
44	-----	2	*WASHER, Flat (Included with Ref. No. 0030)
97	-----	2	*GASKET, Corrugated (Included with Ref. No. 0030)
149	-----	1	*C-CLIP, Shaft (Included with Ref. No. 0030 & 0670)
150	-----	1	*KEY, Woodruff (Included with Ref. No. 0030 & 0670)
151	-----	1	*PIN, Spring (Included with Ref. No. 0030 & 0670)
152	-----	1	*SHAFT, Drive Wheel (Included with Ref. No. 0030)
153	-----	1	*GEAR, Drive (Included with Ref. No. 0030)
154	-----	2	*SLEEVE, Axle (Included with Ref. No. 0030 & 0660)
0660	707532	1	KIT, Axle Sleeve (Incl. Ref. Nos. 154)
154	-----	2	*SLEEVE, Axle (Included with Ref. No. 0030 & 0660)
0670	707530	1	KIT, Bearing Hardware, Axle (Incl. Ref. Nos. 149, 150, & 151)
149	-----	1	*C-CLIP, Shaft (Included with Ref. No. 0030 & 0670)
150	-----	1	*KEY, Woodruff (Included with Ref. No. 0030 & 0670)
151	-----	1	*PIN, Spring (Included with Ref. No. 0030 & 0670)

### Footnotes

Note:\* Not a serviceable part.

The above parts group applies to the following Mfg. Nos.:

1696614-01 - 1024MD

# Decals Group

**NOTE:** Unless noted otherwise, use the standard hardware torque specification chart.

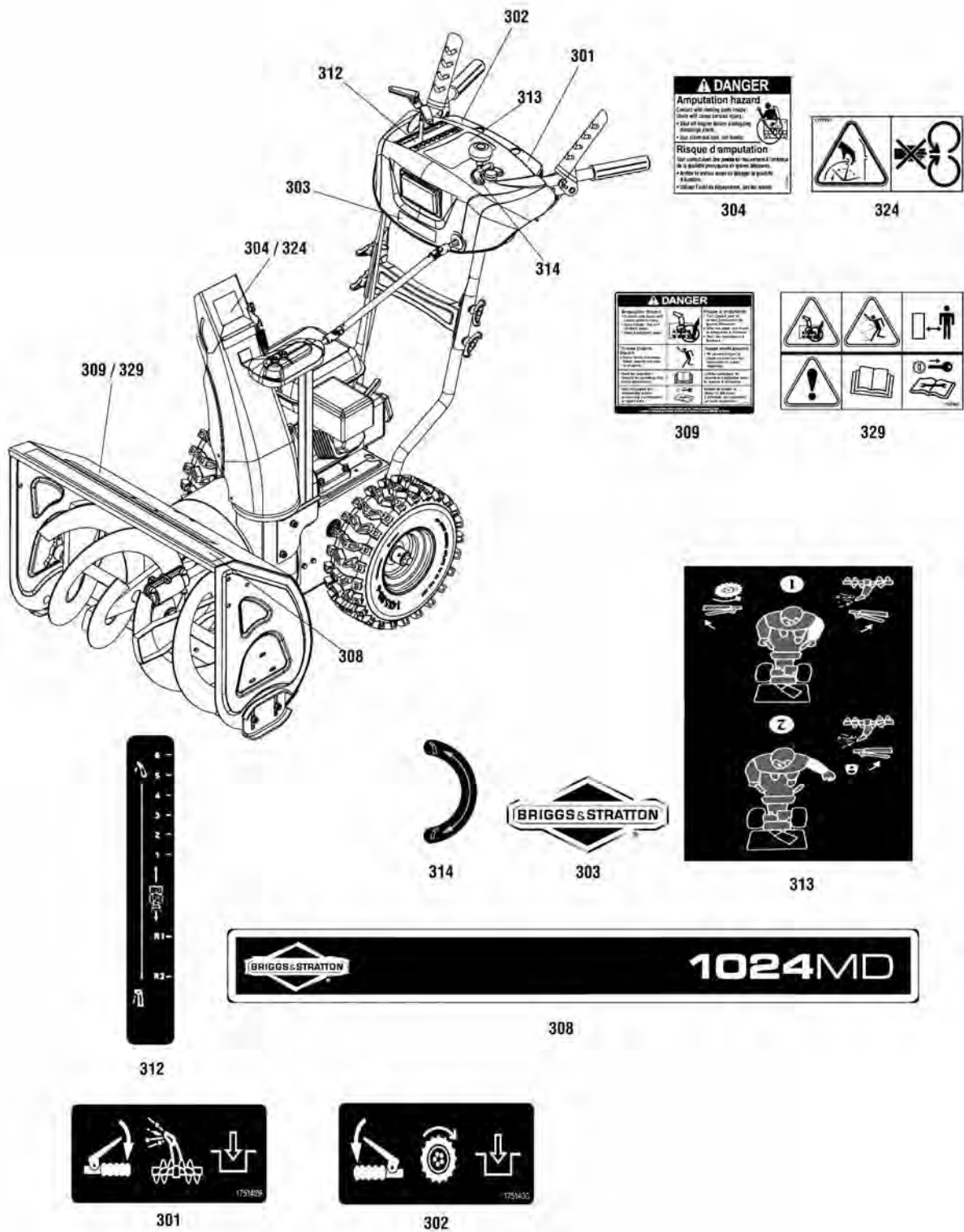

The above parts group applies to the following Mfg. Nos.:  
1696614-01 - 1024MD

## Decals Group

REF NO	PART NO.	QTY.	DESCRIPTION
1	770374	1	KIT-DECAL, Briggs 1024MD (Incl. Ref. No. 301, 302, 303, 304, 308, 309, 312, 313 & 314)
2	770378	1	KIT-DECAL, Briggs 1024MD, Export (Incl. Ref. No. 301, 302, 303, 308, 312, 313 & 314, 324 & 329)
301	-----	1	*DECAL, Auger Control (Included with Ref. No. 1 & 2) (Included with Dash Kit)
302	-----	1	*DECAL, Traction Control (Included with Ref. No. 1 & 2) (Included with Dash Kit)
303	-----	1	*DECAL, Control Panel, Briggs & Stratton (Included with Ref. No. 1 & 2)
304	1737865YP	1	DECAL, Danger Chute (Included with Ref. No. 1)
308	-----	1	*DECAL, Auger Housing, 1024MD (Included with Ref. No. 1 & 2)
309	1737866YP	1	DECAL, Danger Foot (Included with Ref. No. 1)
312	-----	1	*DECAL, 1-6 Transmission Speed Control (Included with Ref. No. 1 & 2) (Included with Dash Kit)
313	-----	1	*DECAL, Free Hand Operation (Included with Ref. No. 1 & 2) (Included with Dash Kit)
314	-----	1	*DECAL, Chute Rotation (Included with Ref. No. 1 & 2) (Included with Dash Kit)
324	1727207SM	1	DECAL, Chute Warning, Export (Included with Ref. No. 2)
329	1737867YP	1	DECAL, Danger Auger Icons, Export (Included with Ref. No. 2)

Not for  
Reproduction

### Footnotes

Note:\* Not a serviceable part.

---

The above parts group applies to the following Mfg. Nos.:

1696614-01 - 1024MD

# Discharge Chute Group

NOTE: Unless noted otherwise, use the standard hardware torque specification chart.

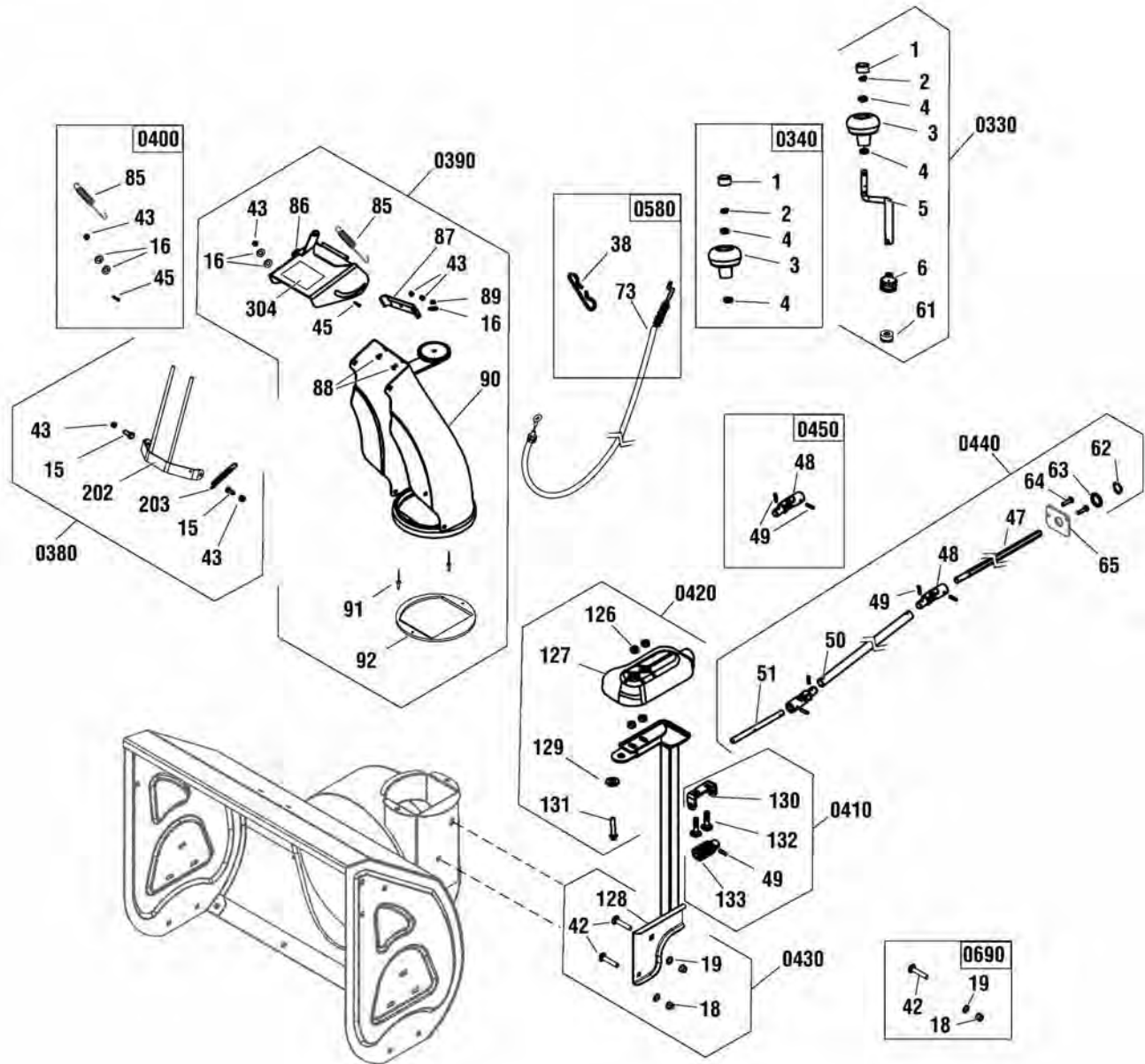

The above parts group applies to the following Mfg. Nos.:  
1696614-01 - 1024MD



## Discharge Chute Group

REF NO	PART NO.	QTY.	DESCRIPTION
0330	707503	1	KIT, Chute Rotation (Incl. Ref. Nos. 1, 2, 3, 4, 5, 6 & 61)
1	-----	1	*COVER, Lever Knob, Chute Rotater (Included with Ref. No. 0330)
2	-----	1	*C-Clip, Shaft (Included with Ref. No. 0330)
3	-----	1	*KNOB, Lever, Chute Rotater (Included with Ref. No. 0330)
4	-----	2	*WASHER, Flat (Included with Ref. No. 0330)
5	-----	1	*LEVER, Chute Rotater (Included with Ref. No. 0330)
6	-----	1	*SLEEVE, Rubber (Included with Ref. No. 0330)
61	-----	1	*SLEEVE, Damping, Chute Rotater Lever (Included with Ref. No. 0330)
0340	707502	1	KIT, Chute Knob (Incl. Ref. Nos. 1, 2, 3 & 4)
1	-----	1	*COVER, Lever Knob, Chute Rotater (Included with Ref. No. 0340)
2	-----	1	*C-CLIP, Shaft (Included with Ref. No. 0340)
3	-----	1	*KNOB, Lever, Chute Rotater (Included with Ref. No. 0340)
4	-----	2	*WASHER, Flat (Included with Ref. No. 0340)
0380	707570	1	KIT, Chute Guard (Incl. Ref. Nos. 15, 43, 202 & 203)(CE/Export Only)
15	-----	2	*SCREW, Hex-Head (Included with Ref. No. 0380)(CE/Export Only)
43	-----	2	*Lock Nut, Hex Head, non-metal (Included with Ref. No. 0380)(CE/Export Only)
202	-----	1	*Chute Guard (Included with Ref. No. 0380)(CE/Export Only)
203	-----	1	*Spring (Included with Ref. No. 0380)(CE/Export ONLY)
0390	707747	1	KIT, Chute Assembly (Domestic Only) (Incl. Ref. Nos. 4, 16, 43, 45, 85, 86, 87, 88, 89, 90, 91 & 92)
0390	707748	1	KIT, Chute Assembly (CE/Export Only) (Incl. Ref. Nos. 4, 16, 43, 45, 85, 86, 87, 88, 89, 90, 91 & 92)
16	-----	2	*WASHER, Flat (Included with Ref. No. 0390)
43	-----	2	*NUT, Hex Head Lock, Non-metal (Included with Ref. No. 0390)
45	-----	1	*SCREW, Non-standard (Included with Ref. No. 0390)
85	-----	1	*SPRING, Tensioned, Chute Deflector (Included with Ref. No. 0390)
86	-----	1	*DEFLECTOR, Chute (Included with Ref. No. 0390)
87	-----	1	*PAD, Chute Rubber (Included with Ref. No. 0390)
88	-----	2	*SCREW, Hex Head (Included with Ref. No. 0390)
89	-----	1	*NUT, Hex Head Lock, Non-metal (Included with Ref. No. 0390)
90	-----	1	*CHUTE (Included with Ref. No. 0390)
91	-----	2	*RIVET, Core (Included with Ref. No. 0390)
92	-----	1	*RING, Chute (Included with Ref. No. 0390)
304	1737865YP	1	*DECAL, Danger Chute (Included with Ref. No. 0390)
304	1727207SM	1	*DECAL, Danger Chute, Export (Included with Ref. No. 0390)
0400	707563	1	KIT, Spring, Chute (Incl. Ref. Nos. 16, 43, 45 & 85)
16	-----	2	*WASHER, Flat (Included with Ref. No. 0400)
43	-----	1	*NUT, Hex Head Lock, Non-metal (Included with Ref. No. 0400)
45	-----	1	*SCREW, Non-standard (Included with Ref. No. 0400)
85	-----	1	*SPRING, Tensioned, Chute Deflector (Included with Ref. No. 0400)
0410	707543	1	KIT, Worm Gear Hardware, Chute (Incl. Ref. Nos. 49, 126, 130, 132 & 133)
49	-----	1	*SPRING, Splitpin (Included with Ref. No. 0410)
130	-----	1	*BRACKET, Worm (Included with Ref. No. 0410)

### Footnotes

Note:\* Not a serviceable part.

The above parts group applies to the following Mfg. Nos.:

1696614-01 - 1024MD

## Discharge Chute Group

NOTE: Unless noted otherwise,  
use the standard hardware torque  
specification chart.

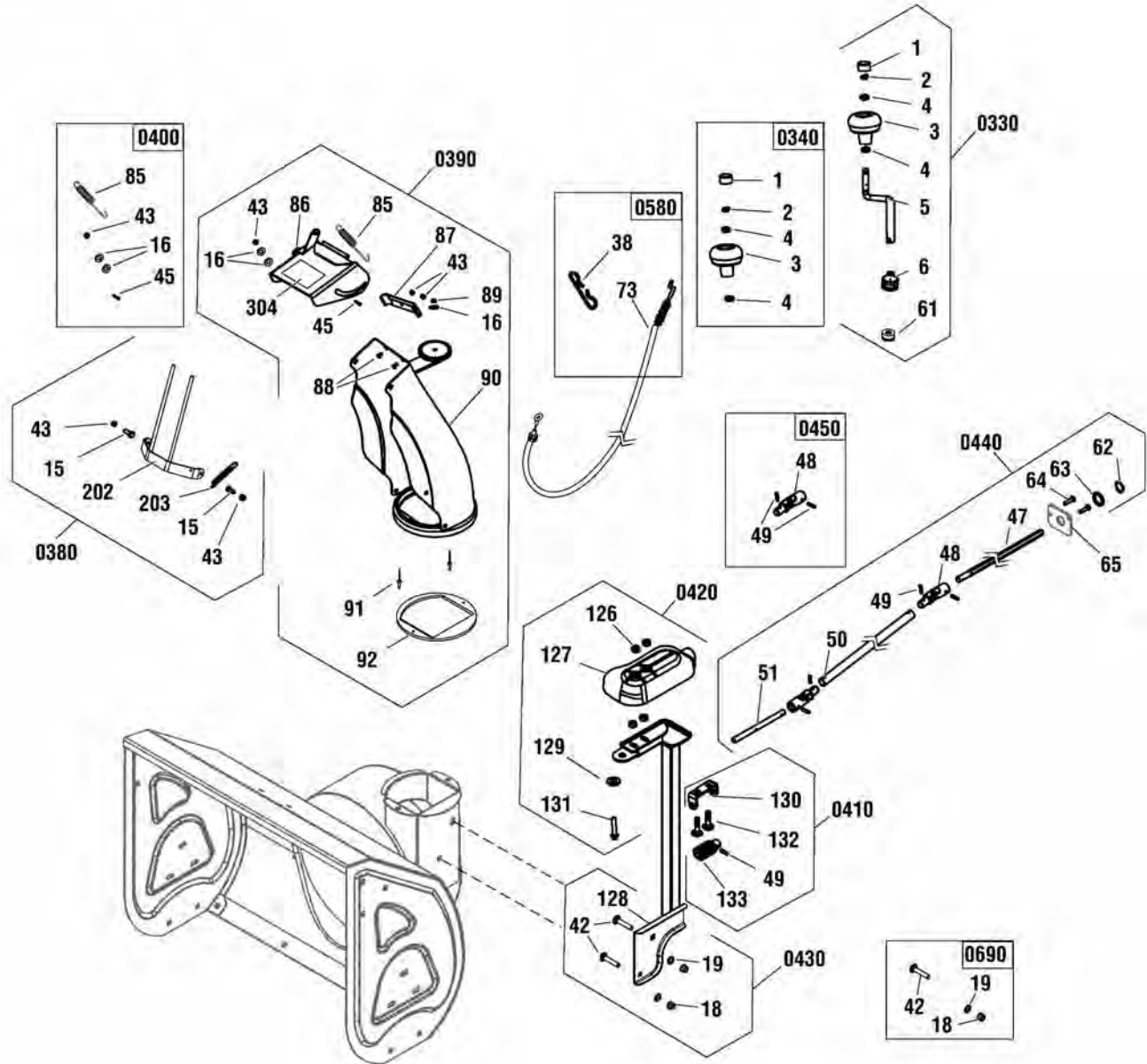

The above parts group applies to the following Mfg. Nos.:  
1696614-01 - 1024MD

## Discharge Chute Group

REF NO	PART NO.	QTY.	DESCRIPTION
0420	707544	1	KIT, Cover, Chute Rotation (Incl. Ref. Nos. 126, 127, 129 & 131)
126	-----	4	*NUT (Included with Ref. No. 0420)
127	-----	1	*HEAD, Chute Rotation (Included with Ref. No. 0420)
129	-----	1	*SELF-LOCK, Assembly, Chute Deflector (Included with Ref. No. 0420)
131	-----	1	*SCREW, Hex Head (Included with Ref. No. 0420)
0430	707545	1	KIT, Bracket, Chute Rotation (Incl. Ref. Nos. 18, 19, 42 & 128)
18	-----	2	*NUT, Hex Head Lock, Non-metal (Included with Ref. No. 0430)
19	-----	2	*WASHER, Flat (Included with Ref. No. 0430)
42	-----	2	*BOLT, Square Neck, Cup Head (Included with Ref. No. 0430)
128	-----	1	*BRACKET, Chute Rotation (Included with Ref. No. 0430)
0440	707525	1	KIT, Chute Rotation Rod (Incl. Ref. Nos. 47, 48, 49, 50, 51, 62, 63 & 64)
47	-----	1	*ROD, Hex, Chute Rotation (Included with Ref. No. 0440)
48	-----	2	*JOINT, Cardan (Included with Ref. No. 0440)
49	-----	4	*SPRING, Splitpin (Included with Ref. No. 0440)
50	-----	1	*ROD, Rotation, Chute (Included with Ref. No. 0440)
51	-----	1	*ROD, Rotation, Chute (Included with Ref. No. 0440)
62	-----	1	*C-CLIP, Shaft (Included with Ref. No. 0440)
63	-----	1	*WASHER, Flat (Included with Ref. No. 0440)
64	-----	2	*SCREW, Hex Head (Included with Ref. No. 0440)
65	-----	1	*SEAT, Bevel Gear
0450	707524	1	KIT, Cardan Joint (Incl. Ref. Nos. 48 & 49)
48	-----	1	*JOINT, Cardan (Included with Ref. No. 0450)
49	-----	2	*SPRING, Splitpin (Included with Ref. No. 0450)
0580	707516	1	KIT, Cable-Chute Deflector (Incl. Ref. Nos. 38 & 73)
38	-----	1	*HOOK, Cable (Included with Ref. No. 0580)
73	-----	1	*CABLE, Chute Deflector (Included with Ref. No. 0580)
0690	709757	1	KIT, Hardware, Chute Rotation (Incl. Ref. Nos. 18, 19 & 42)
18	-----	1	*NUT, Hex Head Lock, Non-metal (Included with Ref. No. 0690)
19	-----	1	*WASHER, Flat (Included with Ref. No. 0690)
42	-----	1	*BOLT, Square Neck, Cup Head (Included with Ref. No. 0690)

### Footnotes

Note:\* Not a serviceable part.

The above parts group applies to the following Mfg. Nos.:

1696614-01 - 1024MD

## Transaxle Drive Group

NOTE: Unless noted otherwise, use the standard hardware torque specification chart.

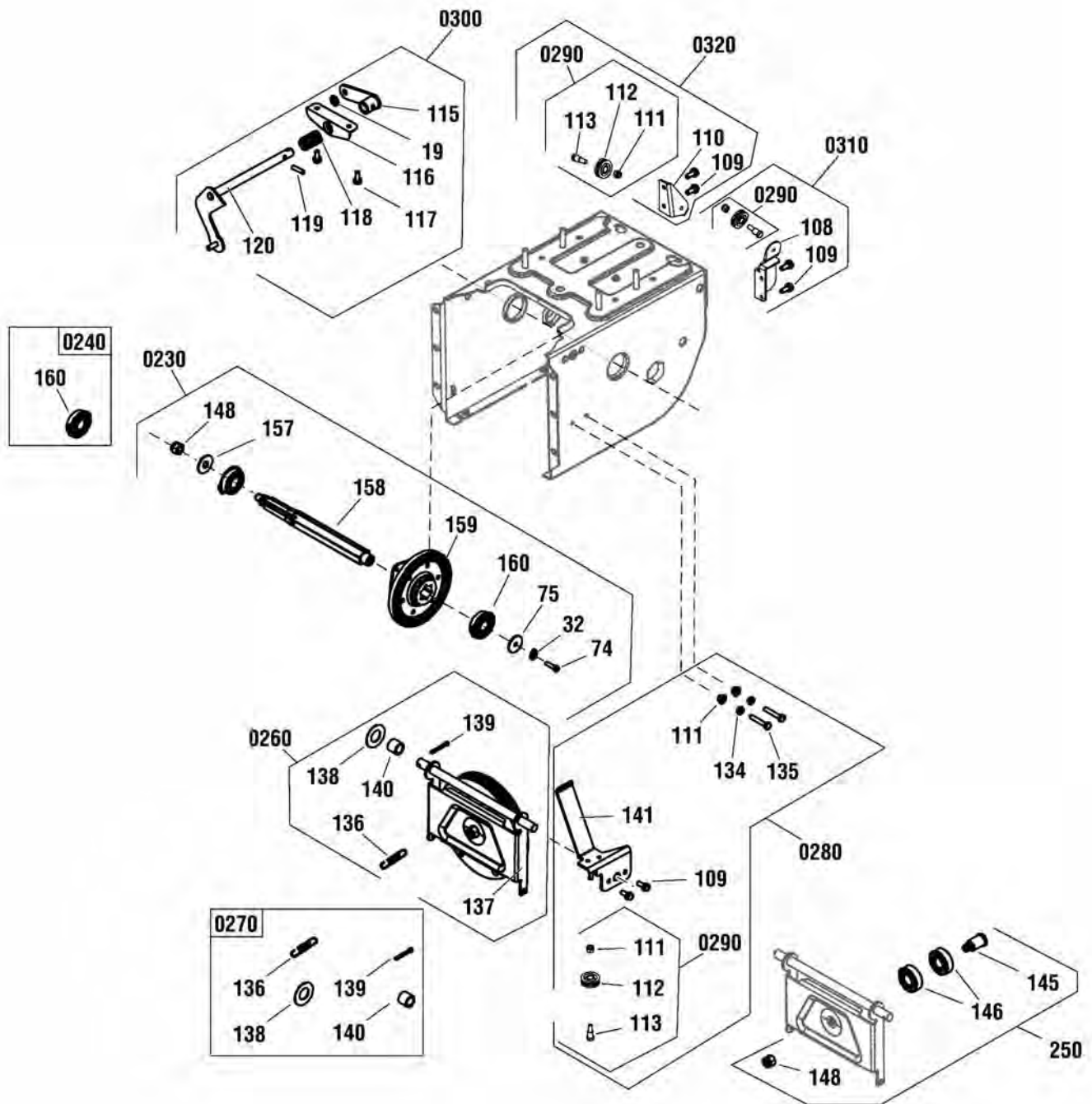

The above parts group applies to the following Mfg. Nos.:  
1696614-01 - 1024MD

## Transaxle Drive Group

REF NO	PART NO.	QTY.	DESCRIPTION
0230	707535	1	KIT, Friction Wheel & Shaft (Incl. Ref. Nos. 32, 74, 75, 148, 157, 158, 159 & 160)
32	-----	1	*WASHER, Spring (Included with Ref. No. 0230)
74	-----	1	*SCREW, Hex Head (Included with Ref. No. 0230)
75	-----	1	*WASHER, Flat (Included with Ref. No. 0230)
148	-----	1	*NUT, Hex Head Lock, Non-metal (Included with Ref. No. 0230)
157	-----	1	*WASHER, Flat (Included with Ref. No. 0230)
158	-----	1	*SHAFT, Hexagonal Gear (Included with Ref. No. 0230)
159	708080	1	WHEEL, Friction Assembly (Included with Ref. No. 0230)
160	-----	2	*BEARING, Ball, Deep Groove (Included with Ref. No. 0230)
0240	707536	1	KIT, Bearing, Friction Wheel & Shaft (Incl. Qty. 2 Ref. No. 160)
160	-----	2	*BEARING, Ball, Deep Groove (Included with Ref. No. 0240)
0250	707539	1	KIT, Bearing, Swinging Plate (Incl. Ref. Nos. 145, 146 & 148)
145	-----	1	*SHAFT, Drive Disk (Included with Ref. No. 0250)
146	-----	2	*BEARING, Ball, Deep Groove (Included with Ref. No. 0250)
148	-----	1	*NUT, Hex Head Lock, Non-metal (Included with Ref. No. 0250)
0260	707540	1	KIT, Swinging Plate (Incl. Ref. Nos. 136, 137, 138, 139 & 140)
136	-----	1	*SPRING (Included with Ref. No. 0260)
137	-----	1	*PLATE, Swinging (Included with Ref. No. 0260)
138	-----	1	*WASHER, Flat (Included with Ref. No. 0260)
139	-----	1	*SPLITPIN (Included with Ref. No. 0260)
140	-----	1	*SLEEVE (Included with Ref. No. 0260)
0270	707538	1	KIT, Spring, Swinging Plate (Incl. Ref. Nos. 136, 138, 139 & 140)
136	-----	1	*SPRING (Included with Ref. No. 0270)
138	-----	1	*WASHER, Flat (Included with Ref. No. 0270)
139	-----	1	*SPLITPIN (Included with Ref. No. 0270)
140	-----	1	*SLEEVE (Included with Ref. No. 0270)
0280	770079	1	KIT, Belt Guide (Incl. Ref. Nos. 109, 111, 112, 113, 134, 135 & 141)
109	-----	2	*SCREW, Hex Head (Included with Ref. No. 0280)
111	-----	3	*SCREW, Flange, Hex Head (Included with Ref. No. 0280)
112	-----	1	*PULLEY, Cable (Included with Ref. No. 0280)
113	-----	1	*BOLT (Included with Ref. No. 0280)
134	-----	2	*WASHER, Flat (Included with Ref. No. 0280)
135	-----	2	*SCREW, Hex Head (Included with Ref. No. 0280)
141	-----	1	*PLATE, Belt Pressing (Included with Ref. No. 0280)
0290	707541	1	KIT, Pulley, Cable (Incl. Ref. Nos. 111, 112 & 113)
111	-----	1	*SCREW, Flange, Hex Head (Included with Ref. No. 0290)
112	-----	1	*PULLEY, Cable (Included with Ref. No. 0290)
113	-----	1	*BOLT (Included with Ref. No. 0290)
0300	707527	1	KIT, Shift Rod (Incl. Ref. Nos. 19, 115, 116, 117, 118, 119 & 120)
19	-----	1	*WASHER, Flat (Included with Ref. No. 0300)
115	-----	1	*ARM, Shift Fork (Included with Ref. No. 0300)
116	-----	1	*BASE, Shift Fork (Included with Ref. No. 0300)
117	-----	2	*SCREW, Hex Head (Included with Ref. No. 0300)

### Footnotes

Note:\* Not a serviceable part.

The above parts group applies to the following Mfg. Nos.:

1696614-01 - 1024MD

## Transaxle Drive Group

NOTE: Unless noted otherwise,  
use the standard hardware torque  
specification chart.

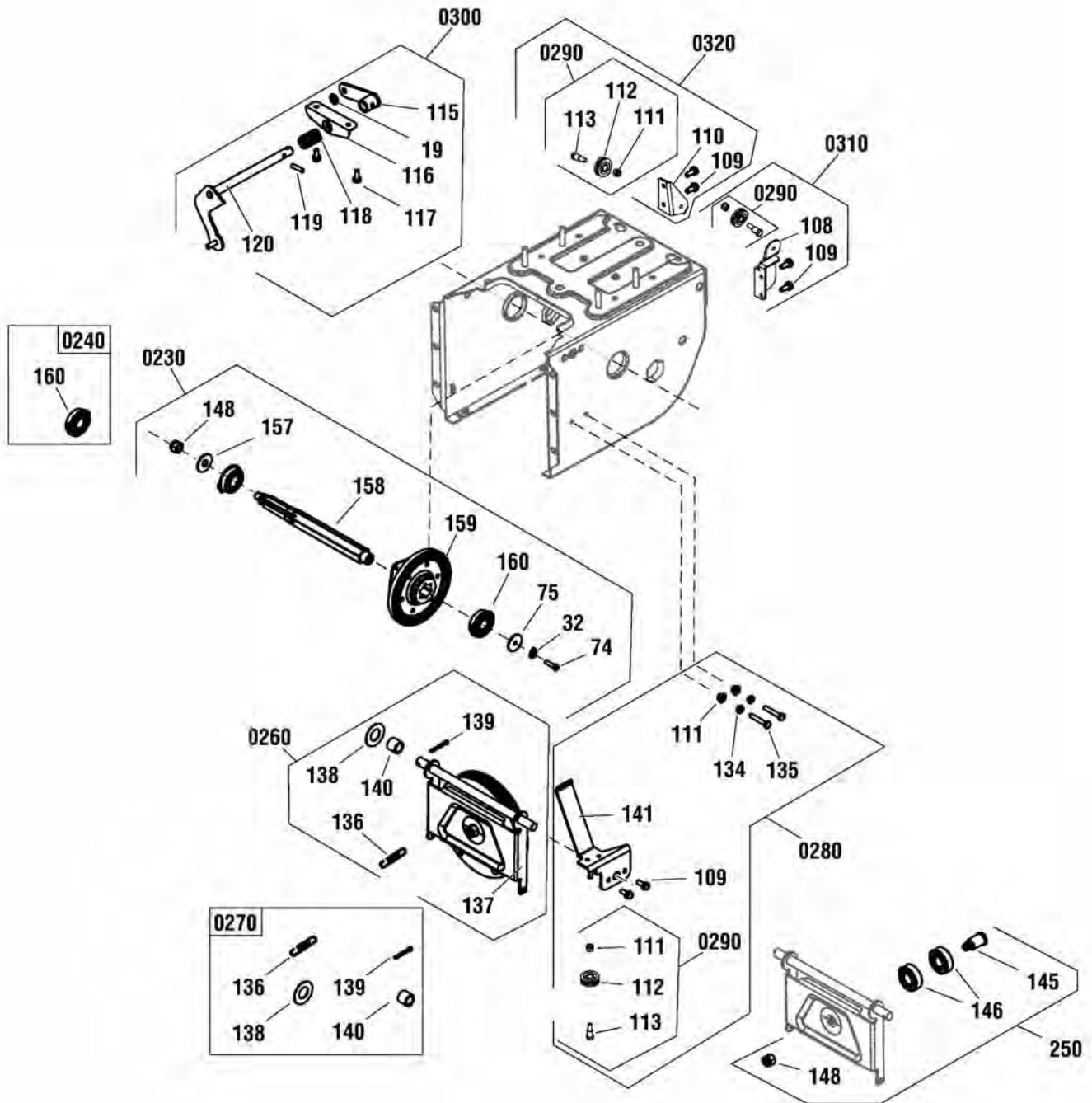

The above parts group applies to the following Mfg. Nos.:  
1696614-01 - 1024MD

## Transaxle Drive Group

REF NO	PART NO.	QTY.	DESCRIPTION
118	----	1	*SPRING, Regulating (Included with Ref. No. 0300)
119	----	1	*PIN, Spring (Included with Ref. No. 0300)
120	----	1	*FORK, Shift (Included with Ref. No. 0300)
0310	707528	1	KIT, Cable Base, Auger Drive (Incl. Ref. Nos. 108, 109, 111, 112 & 113)
108	----	1	*BASE, Cable (Included with Ref. No. 0310)
109	----	2	*SCREW, Hex Head (Included with Ref. No. 0310)
111	----	1	*SCREW, Flange, Hex Head (Included with Ref. No. 0310)
112	----	1	*PULLEY, Cable (Included with Ref. No. 0310)
113	----	1	*BOLT (Included with Ref. No. 0310)
0320	707529	1	KIT, Cable Base, Traction Drive (Incl. Ref. Nos. 109, 110, 111, 112 & 113)
109	----	2	*SCREW, Hex Head (Included with Ref. No. 0320)
110	----	1	*PULLEY, Mounting Plate (Included with Ref. No. 0320)
111	----	1	*SCREW, Flange, Hex Head (Included with Ref. No. 0320)
112	----	1	*PULLEY, Cable (Included with Ref. No. 0320)
113	----	1	*BOLT (Included with Ref. No. 0320)
114	----	1	*BOX, Frame

Not for  
Reproduction

### Footnotes

Note:\* Not a serviceable part.

---

The above parts group applies to the following Mfg. Nos.:

1696614-01 - 1024MD

Not for  
Reproduction



Not for  
Reproduction

Not for  
Reproduction

# Hardware Identification & Torque Specifications

Torque Specification Chart								
FOR STANDARD METRIC MACHINE HARDWARE (Tolerance ± 20%)								
Property Class	5.6		8.8		10.9		12.9	
	Class 5.6		Class 8.8		Class 10.9		Class 12.9	
Size Of Hardware	in/lbs		in/lbs		in/lbs		in/lbs	
	ft/lbs	Nm.	ft/lbs	Nm.	ft/lbs	Nm.	ft/lbs	Nm.
M3	5.88	.56	13.44	1.28	19.2	1.80	22.92	2.15
M4	13.44	1.28	30.72	2.90	43.44	4.10	52.56	4.95
M5	26.4	2.50	60.96	5.75	5.97	8.10	7.15	9.7
M6	44.64	4.3	7.3	9.9	10.3	14	12.1	16.5
M7	5.2	7.1	12.1	16.5	16.9	23	19.9	27
M8	7.7	10.5	17.7	24	25	34	29	40
M10	15	21	35	48	50	67	59	81
M12	26	36	61	83	86.2	117	103	140
M14	42	58	101	132	136	185	162	220
M16	64	88	147	200	210	285	250	340
M18	89	121	202	275	287	390	346	470
M20	126	171	290	390	405	550	486	660
M22	169	230	390	530	559	745	656	890
M24	217	295	497	375	708	960	840	1140
M27	320	435	733	995	1032	1400	1239	1680
M30	435	590	995	1350	1401	1900	1681	2280
M33	590	800	1349	1830	1902	2580	2278	3090
M36	759	1030	1740	2360	2441	3310	2935	3980
M39	988	1340	2249	3050	3163	4290	3798	5150

The guides and ruler furnished below are designed to help you select the appropriate hardware.

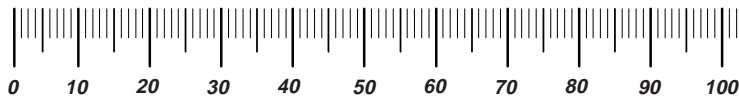

**Nut, M8**

Thread Diameter (mm)  
Inside Diameter (in)  
Threads per inch

**Nut, 1/2-16**

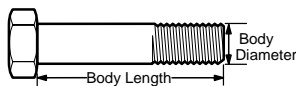

**Screw, M8- 1.25 x 25**

Thread Diameter (mm)  
Body Diameter  
Distance between threads (mm)  
Threads per inch  
Body Length (mm)  
Body Length (in)

**Screw, 1/2- 16 x 2**

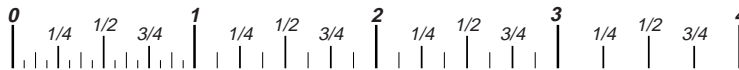

## Standard Hardware Sizing

When a washer or nut is identified as **1/2"** (M8), this is the *Nominal size*, meaning the *inside diameter* is 1/2 inch (8mm metric thread diameter); if a second number is present it represents the *threads per inch* (distance between threads).

When bolt or capscrew is identified as **1/2 - 16 x 2"** (M8 - 1.25 x 50 ), this means the *Nominal size*, or body diameter is 1/2 inch (8mm metric thread diameter), the second number, 16, represents the *threads per inch*, (1.25 thread diameter). The final number is the body length of the bolt or screw, 2 inches (50mm).

Torque Specification Chart						
FOR STANDARD MACHINE HARDWARE (Tolerance ± 20%)						
Hardware Grade	No Marks		SAE Grade 5		SAE Grade 8	
	SAE Grade 2		SAE Grade 5		SAE Grade 8	
Size Of Hardware	in/lbs		in/lbs		in/lbs	
	ft/lbs	Nm.	ft/lbs	Nm.	ft/lbs	Nm.
8-32	19	2.1	30	3.4	41	4.6
8-36	20	2.3	31	3.5	43	4.9
10-24	27	3.1	43	4.9	60	6.8
10-32	31	3.5	49	5.5	68	7.7
1/4-20	66	7.6	8	10.9	12	16.3
1/4-28	76	8.6	10	13.6	14	19.0
5/16-18	11	15.0	17	23.1	25	34.0
5/16-24	12	16.3	19	25.8	29	34.0
3/8-16	20	27.2	30	40.8	45	61.2
3/8-24	23	31.3	35	47.6	50	68.0
7/16-14	30	40.8	50	68.0	70	95.2
7/16-20	35	47.6	55	74.8	80	108.8
1/2-13	50	68.0	75	102.0	110	149.6
1/2-20	55	74.8	90	122.4	120	163.2
9/16-12	65	88.4	110	149.6	150	204.0
9/16-18	75	102.0	120	163.2	170	231.2
5/8-11	90	122.4	150	204.0	220	299.2
5/8-18	100	136	180	244.8	240	326.4
3/4-10	160	217.6	260	353.6	386	525.0
3/4-16	180	244.8	300	408.0	420	571.2
7/8-9	140	190.4	400	544.0	600	816.0
7/8-14	155	210.8	440	598.4	660	897.6
1-8	220	299.2	580	788.8	900	1,244.0
1-12	240	326.4	640	870.4	1,000	1,360.0

## NOTES

- These torque values are to be used for all hardware excluding: locknuts, self-tapping screws, thread forming screws, sheet metal screws and socket head setscrews.
- Recommended seating torque values for locknuts:
  - for prevailing torque locknuts - use 65% of grade 5 torques.
  - for flange whizlock nuts and screws - use 135% of grade 5 torques.
- Unless otherwise noted on assembly drawings, all torque values must meet this specification.

## Common Hardware Types

Hex Head Capscrew

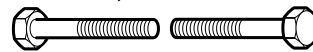

Washer

Carriage Bolt

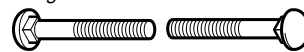

Lockwasher



Hex Nut

## Wrench & Fastener Size Guide

1/4" Bolt or Nut Wrench—7/16"	5/16" Bolt or Nut Wrench—1/2"	3/8" Bolt or Nut Wrench—9/16"	7/16" Bolt or Nut Wrench (Bolt)—5/8" Wrench (Nut)—11/16"	1/2" Bolt or Nut Wrench—3/4"
M6 Bolt or Nut Wrench—10mm	M8 Bolt or Nut Wrench—13mm	M10 Bolt or Nut Wrench—17mm	M12 Bolt or Nut Wrench—19mm	M14 Bolt or Nut Wrench—22mm



Not for  
Reproduction

**IT IS THE POLICY OF BRIGGS & STRATTON CORP. TO IMPROVE ITS PRODUCTS  
WHENEVER IT IS POSSIBLE AND PRACTICAL TO DO SO. WE RESERVE THE RIGHT TO  
MAKE CHANGES OR ADD IMPROVEMENTS AT ANY TIME WITHOUT INCURRING ANY  
OBLIGATION TO MAKE SUCH CHANGES ON PRODUCTS.**

**Briggs & Stratton Power Products Group**

---

12301 W. Wirth Street  
Wauwatosa, WI, 53222 USA

[www.BRIGGSandSTRATTON.com](http://www.BRIGGSandSTRATTON.com)

© Copyright 2016 by Briggs & Stratton Corporation  
Milwaukee, WI, USA. All rights reserved