

Telescoping housing extends from 3.75" - 6.50"
Diameter 8.1875"

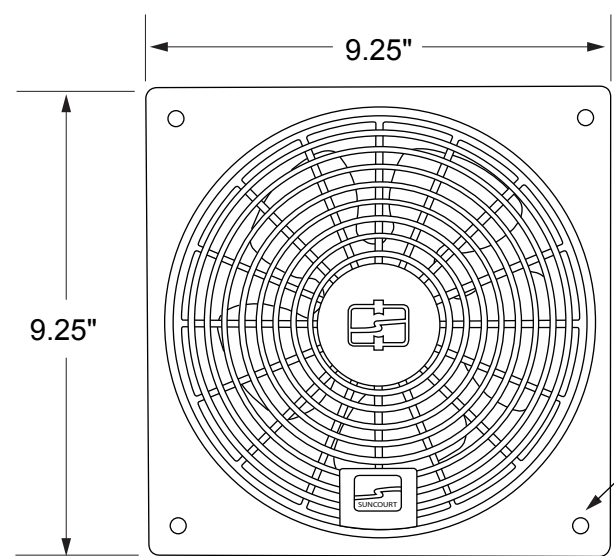

Front View

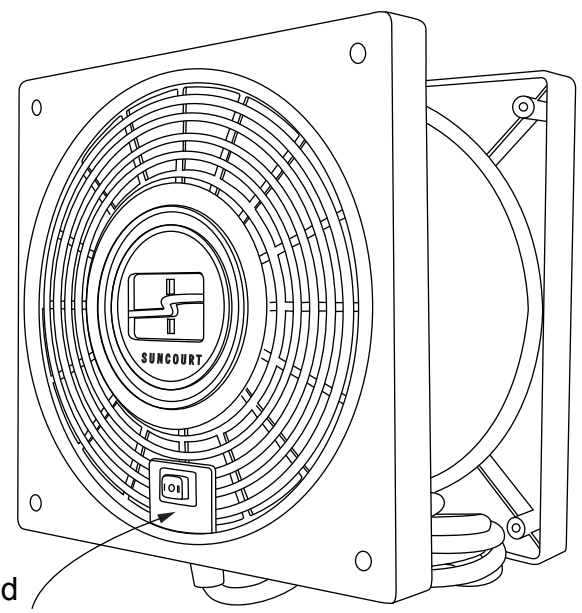

10' SJT power cord with molded on grounded plug

0.125" Diameter screw mounting hole

N.T.S.



ThruWall™ Room To Room Fan™

Model: TW408 2-Speed w/ Airflow Adapter

Quietly and efficiently moves heated or cooled air from one room to another.

Running Watts: 29 Low / 40 High • AMPS: 0.75 • VAC: 120 • HZ: 60 • dBA: 54
Unit weight: 4.65 lbs. • UL® listed • Blade type: Polycarbonate
One year limited warranty

SUNCOURT INC.
P.O. Box 40
Durant, IA 52747-0040
1.800.999.FANS (3267)
www.suncourt.com