

SWISHER®

COMMERCIAL PRO

RESPONSE

with

Patented

**RAPID
RESPONSE
CONTROL
SYSTEM**

Models:

Z21554CPHO
Z21554CPHO-CA
Z21560CPHO
Z21560CPHO-CA
Z2460CPKA
Z2460CPKA-CA
Z2466CPKA
Z2466CPKA-CA

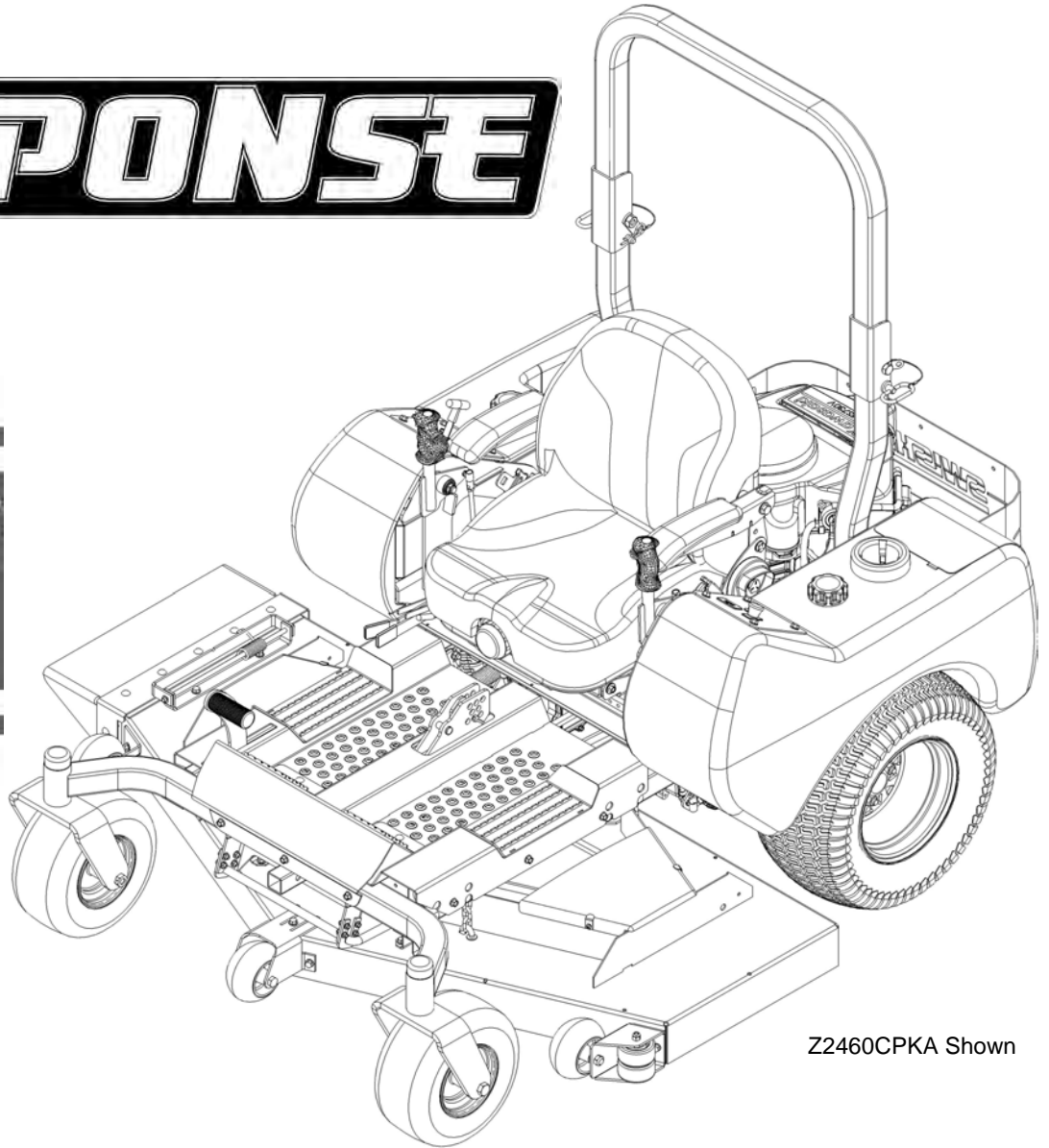

Z2460CPKA Shown

SWISHER ACQUISITION INC.
1602 CORPORATE DRIVE, WARRENSBURG MISSOURI 64093
PHONE: 660-747-8183 FAX: 660-747-8650
TOLL FREE: 1-800-222-8183

Manufacturing quality lawn care equipment since 1945,
Celebrating over 70 years of innovation



ILLUSTRATED PARTS MANUAL

STARTING SERIAL # L116-336001

PARTS BREAKDOWN

Item #	Part #	Description	Qty.
1	18705*	Weldment - Rear Frame, ROPS	1
2	20648*	Weldment - Front Frame	1
3	18860	Kit - ROPS, Fully Assembled, Txt Blk	1
4	20693*	Wrap - Engine; Txt Blk	1
5	B98	Bearing	4
6	18581	Plug - Finishing, 1 x 3 x .083 Tube	2
7	18629	Plug - Finishing, 3/4 x 3/4 x .120 Tube	4
8	18635	Bolt - Carriage 5/16-18 x 6; GR5, Full Thrd	4
9	18589	Bolt - Hex, 1/2-13 x 6 1/4; GR8, ZP	4
10	NB177	Washer - Mach 1/2 NR 14 GA.	16
11	12669	Bolt - 1/2-13 x 3 1/4; GR8, ZY	4
12	NB121	Nut - 2-Way Jam Lock, 1/2-13, ZY	8
13	26X249	Screw - 5/16-18 X 3/4	7
14	NB515	Bolt - Serr Flange 5/16-18 x 1 3/4; GR5, ZY	8
15	NB170	Nut - Serr Flange 5/16-18 ; Case Hrd, ZY	8

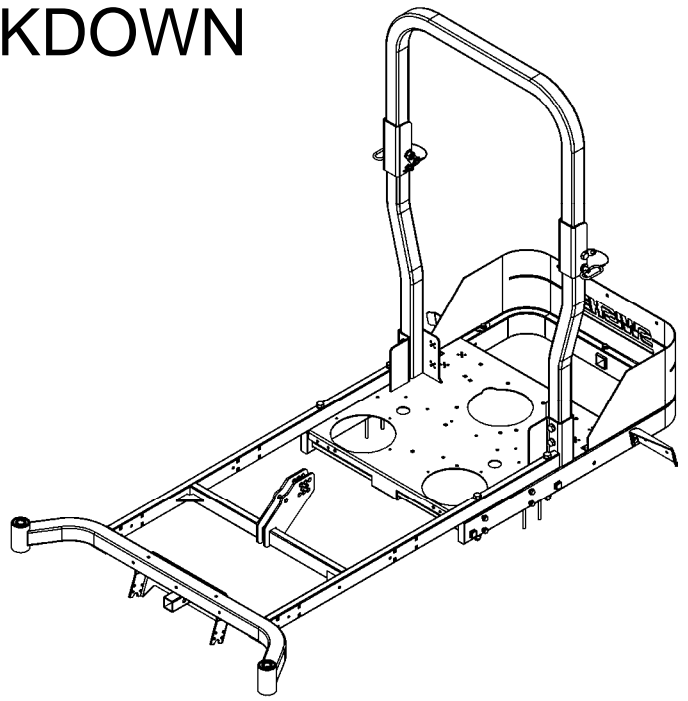

Notes:

Torque settings for bolt number 9 should be set at 25 ft./lbs.

Torque settings for bolt number 11 should be set at 75 ft./lbs.

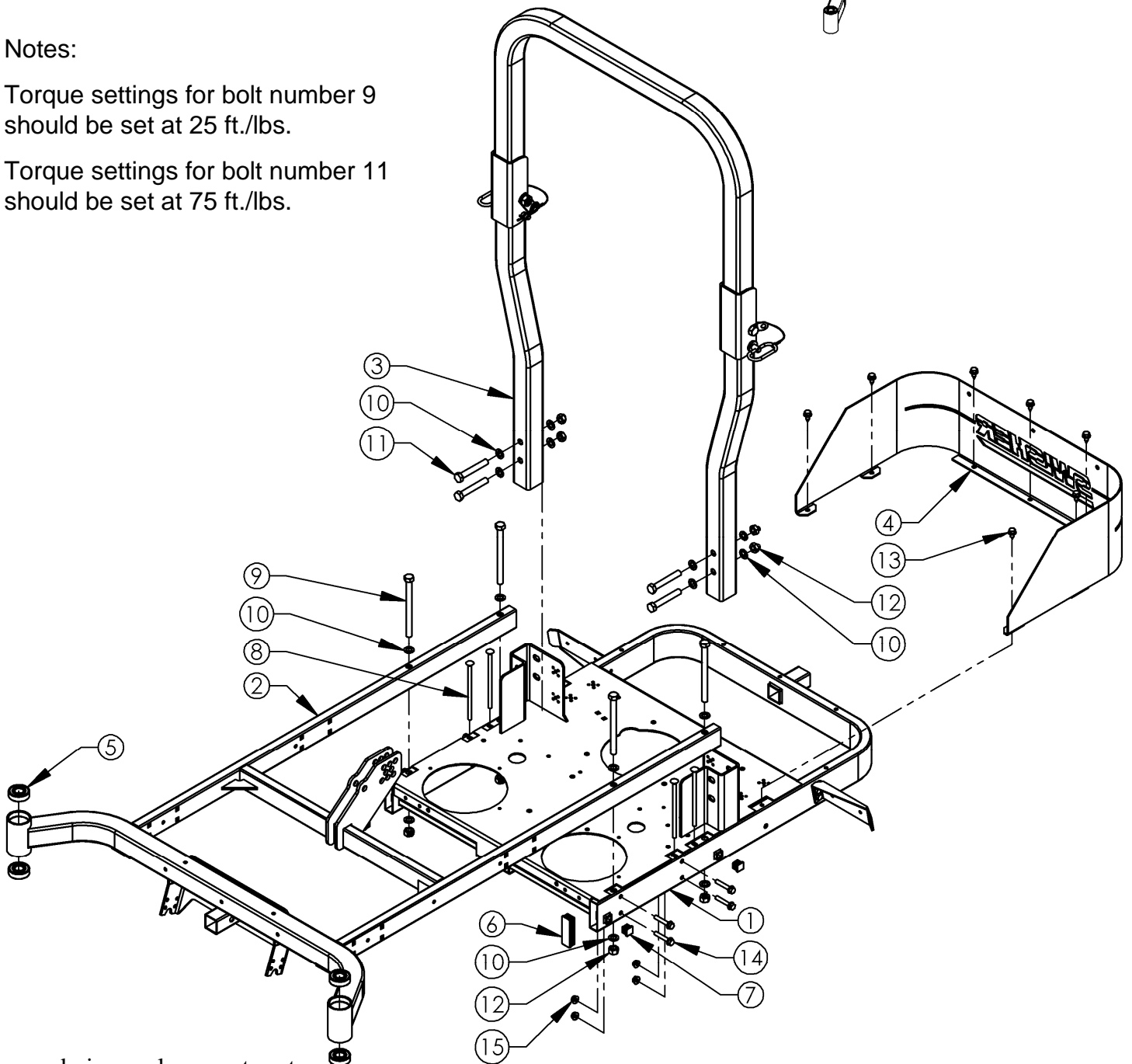

When ordering replacement parts
*USE PAINT CODE: TK=BLACK

PARTS BREAKDOWN

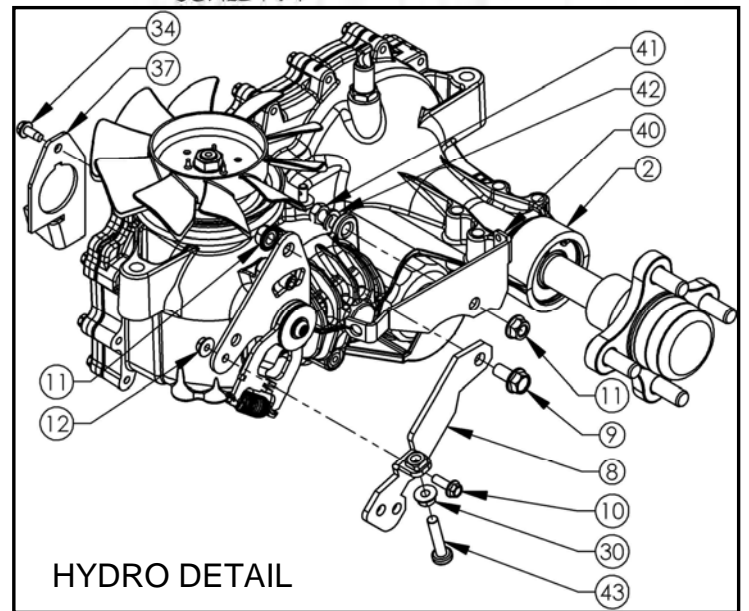
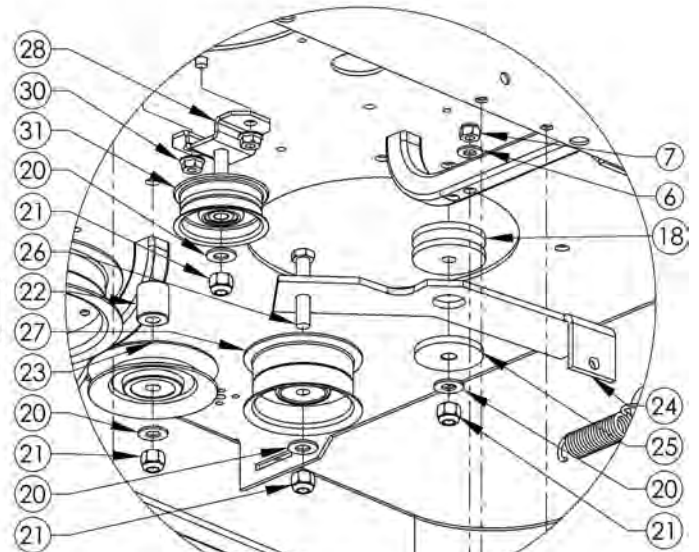
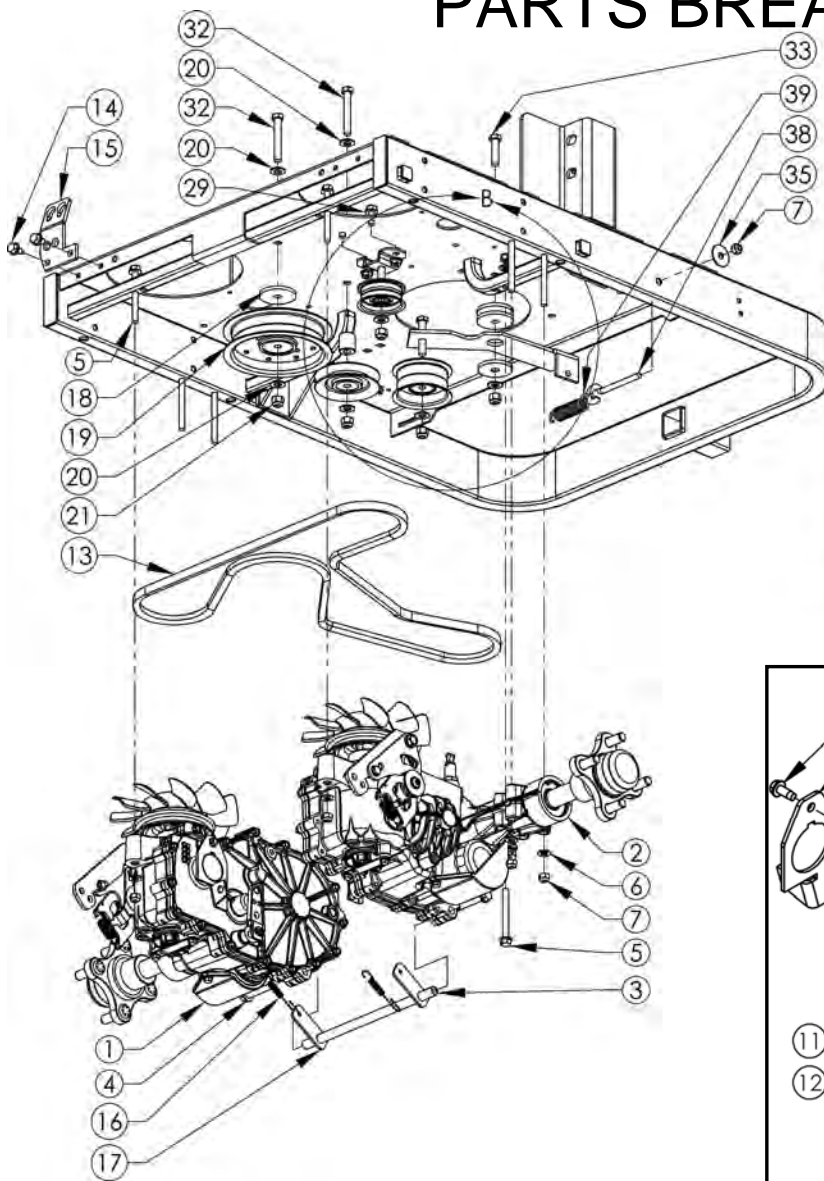

Tip: Item 43 can be adjusted to limit the speed of the hydrostat if tracking adjustments are needed.

Item #	Part #	Description	Qty.
1	20107	Hydrostat - Hydro-Gear ZT3100, Right	1
2	20106	Hydrostat - Hydro-Gear ZT3100, Left	1
3	18858*	Weldment - Hydro Link Support	1
4	NB515	Bolt - Serr Flange, 5/16-18 x 1 3/4; GR5, ZY	2
5	18580	Bolt - Serr Flange, 5/16-18 x 3; GR5, ZP	4
6	NB275	Washer - SAE Flat, 5/16; ZY	8
7	NB181	Nut - Nyloc, 5/16-18; ZY	9
8	19624*	Weldment - Hydro Control, Left	1
	19625*	Weldment - Hydro Control, Right	1
9	NB780	Bolt - Serr Flange, 3/8-16 x 3/4; GR5, ZY	2
10	NB690	Bolt - Serr Flange, 1/4-20 x 3/4; GR5, ZY	2
11	NB779	Nut - Serr Flange, 3/8-16; ZY	4
12	NB524	Nut - Serr Flange, 1/4-20: GR5, ZY	2
13	18811	Belt - Hydro; 1/2 x 80 1/4"	1
14	26X249	Screw - .313-18 x .75	2
15	18938*	Bracket - Bulkhead Cable Mount	1
16	17465	Spring - Extension, Hydro Release, ZT	2
17	18952*	Plate - Brake Spring Return	2
18	6040Z	Washer - Idler, 3/8: ZP	3
19	18607	Pulley - Backside Idler, 5"	1
20	NB272	Washer - SAE Flat, 3/8; Carbon Steel, ZY	7
21	NB182	Nut - Nyloc, 3/8-16; ZY	5
22	18628	Spacer - 7/8 OD x 3/8 ID x 1"	1

Item #	Part #	Description	Qty.
23	3622	Pulley - V, Idler; 3.54 OD x 3/8 ID	1
24	18674*	Plate - Idler	1
25	6037	Bushing - Idler	1
26	NB198	Bolt - HCC, 3/8-16 x 2; GR5, ZY	1
27	7509	Pulley - Idler, 2 3/4 OD x 3/8 ID	1
28	18714*	Weldment - Idler Pulley Offset	1
29	NB596	Bolt - Serr Flange, 5/16-18 x 3/4; GR5, ZY	2
30	NB170	Nut - Serr Flange, 5/16-18; Case Hard, ZY	4
31	B27	Pulley - Idler, 2.16 OD x 3/8 ID	1
32	NB221	Bolt - HCC, 3/8-16 x 2 1/2; GR5, ZY	2
33	NB107	Bolt - HCC, 3/8-16 x 1 1/2; GR5, ZY	1
34	0025X3	Screw - 1/4-20 x 1/2, Thread Form Hex	2
35	NB579	Washer - Fender, 5/16 x 1 1/4; GR2, ZY	1
36	NB231	Bolt - HTC, 3/8-16 x 2; GR5, ZY	2
37	18950*	Bracket - Brake Cable, Left	1
	18949*	Bracket - Brake Cable, Right	1
38	NB315	Eyebolt - 5/16-18 x 3; w/ Gap, ZY	1
39	7821	Spring - Latch	1
40	18941*	Mount - Bypass Cable, Left	1
	18940*	Mount - Bypass Cable, Right	1
41	NB604	Bolt - 3/8-16 X 1 GR5 ZY	2
42	NB711	Washer - Split Lock, 3/8 ZY, Medium	2
43	NB591	Bolt - 5/16-18 X 1 1/2 Torx Pan	2

When ordering replacement parts

*USE PAINT CODE: TK=BLACK

PARTS BREAKDOWN

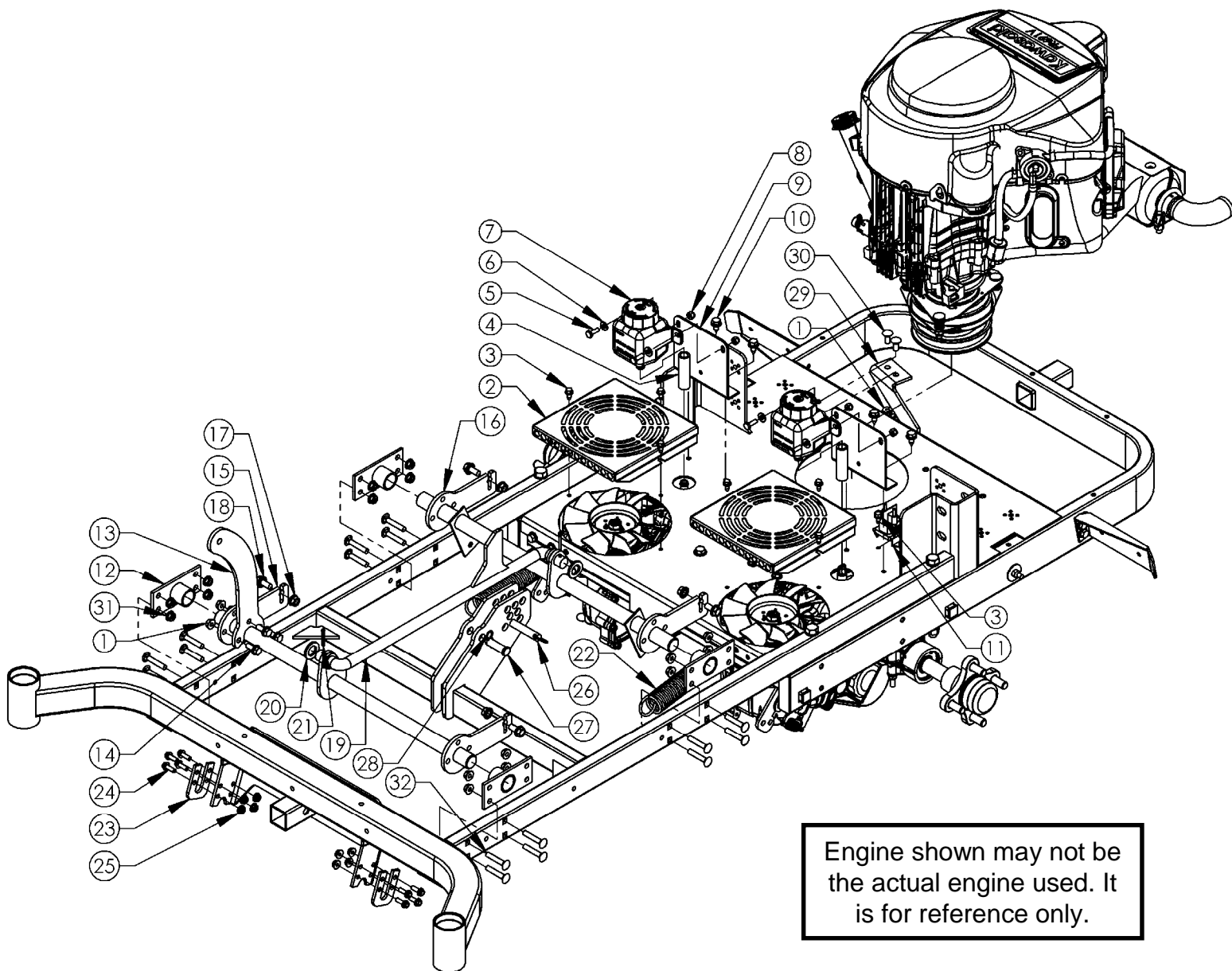

Item #	Part #	Description	Qty.
1	NB170	Nut - Serr Flange, 5/16-18	5
2	18691*	Cover - Hydro Fan	2
3	NB114	Bolt - TCS, 1/4-20 x 1/2; Unslot, GR2, ZY	8
4	AS161	Hose - Bulk, Oil Drain	2.5" x2
5	NB250	Bolt - 1/4-20 x 3/4; GR5, ZY	4
6	NB274	Washer - SAE Flat, 1/4; ZY	4
7	17015	Tank Expansion - Hydro Reservoir (71328)	2
8	NB180	Nut - Nyloc, 1/4-20	4
9	18696*	Bracket - Hydro Expansion Tank	2
10	26X249	Screw - 5/16-18 x 3/4	4
11	1002004	Solenoid - 3 Pole	1
12	18709*	Weldment - Contnmt. Rocker Shaft	4
13	18614*	Plate - Deck Lift Pedal	1
14	NB596	Bolt - Serr Flange, 5/16-18 x 3/4; GR5, ZY	3
15	19115*	Weldment - Rocker Shaft, Front	1
16	19114*	Weldment - Rocker Shaft, Rear	1

Item #	Part #	Description	Qty.
17	NB779	Nut - Serr Flange, 3/8-16; ZY	4
18	NB780	Bolt - Serr Flange, 3/8-16 x 3/4; GR5, ZY	4
19	18592	Weldment - Deck Height Stop Rod	1
20	NB184	Washer - 3/4ID x 1 1/4 OD x 10 GA.	2
21	NB126	Pin - Cotter, 1/8 x 1"; Carbon Steel	2
22	2335	Spring - Tilt	2
23	18650*	Plate - Drag Link Capture	2
24	NB690	Bolt - Serr Flange, 1/4-20 x 3/4; GR5, ZY	8
25	NB524	Nut - Serr Flange, 1/4-20; GR5, ZY	8
26	NB651	Pin - Ball Lock, 1/2 x 2 1/2	1
27	18602	Pin - Clevis 1/2 OD x 1-33/64	1
28	NB127	Pin - Hair, #39; Std, ZY	1
29	18667*	Bracket - Clutch Stop (Kawasaki Models)	1
	20960*	Bracket - Clutch Stop (Honda Models)	1
30	10216	Bolt - Carriage, 5/16-18 x 3/4; GR5, ZY	2
31	20237	Nut - Serr Flange 5/16-18	16
32	20653	Bolt - Carriage, 5/16-18X1.75	16

When ordering replacement parts

*USE PAINT CODE: TK=BLACK

PARTS BREAKDOWN

HONDA ENGINE DETAIL

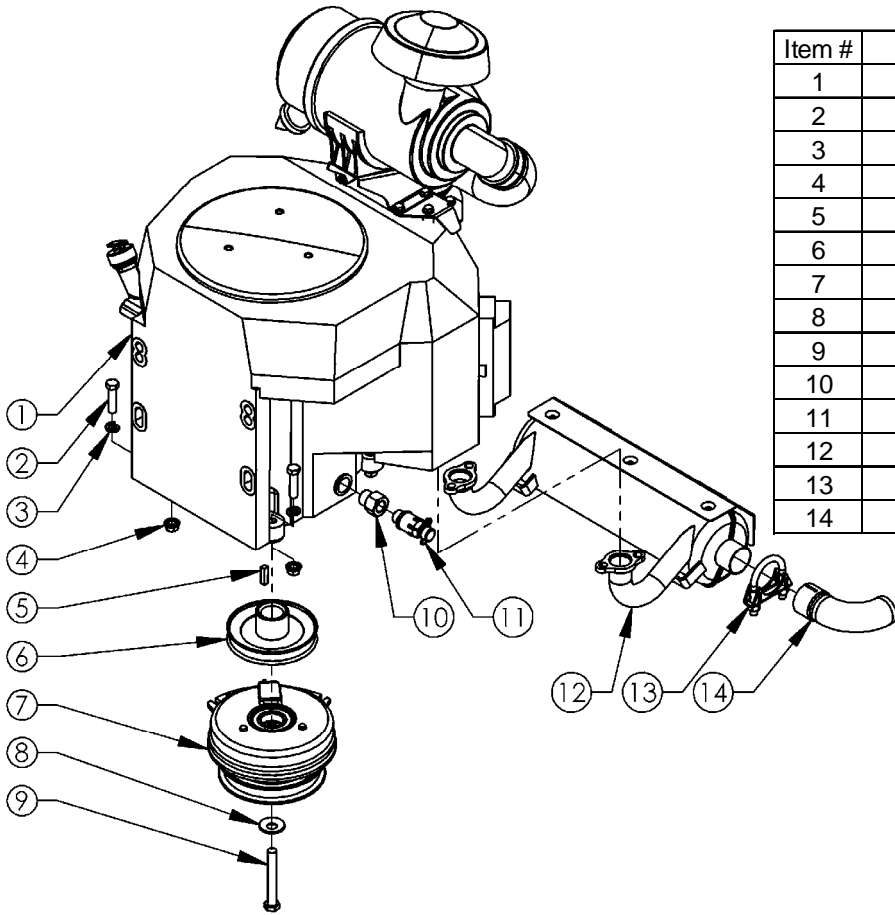

Item #	Part #	Description	Qty.
1	NA	Engine - 21.5 HP Honda	1
2	NB107	Bolt - 3/8-16 X 1 1/2	4
3	NB711	Washer - Split Lock, 3/8	4
4	NB779	Nut - Serrated Flange, 3/8-16	4
5	9031	Key Stock - 1/4 X 1	1
6	19285	Pulley - Engine, Ø1.125" Bore	1
7	19433	Clutch - Ø1 1/8", 125 ft/lbs	1
8	10291	Washer - Belleville, .512 X 1.26 X .138	1
9	NB705	Bolt - HCF, 7/16-20 X 3.25	1
10	20881	Adapter - Oil Drain, Honda	1
11	16000	Valve - Oil Drain	1
12	20882	Muffler - Honda	1
13	18876	Clamp - Muffler	1
14	18853	Deflector - Muffler Turn Down, 90°	1

Notes:

Torque settings for bolt number 9 should be set at 20 ft./lbs.

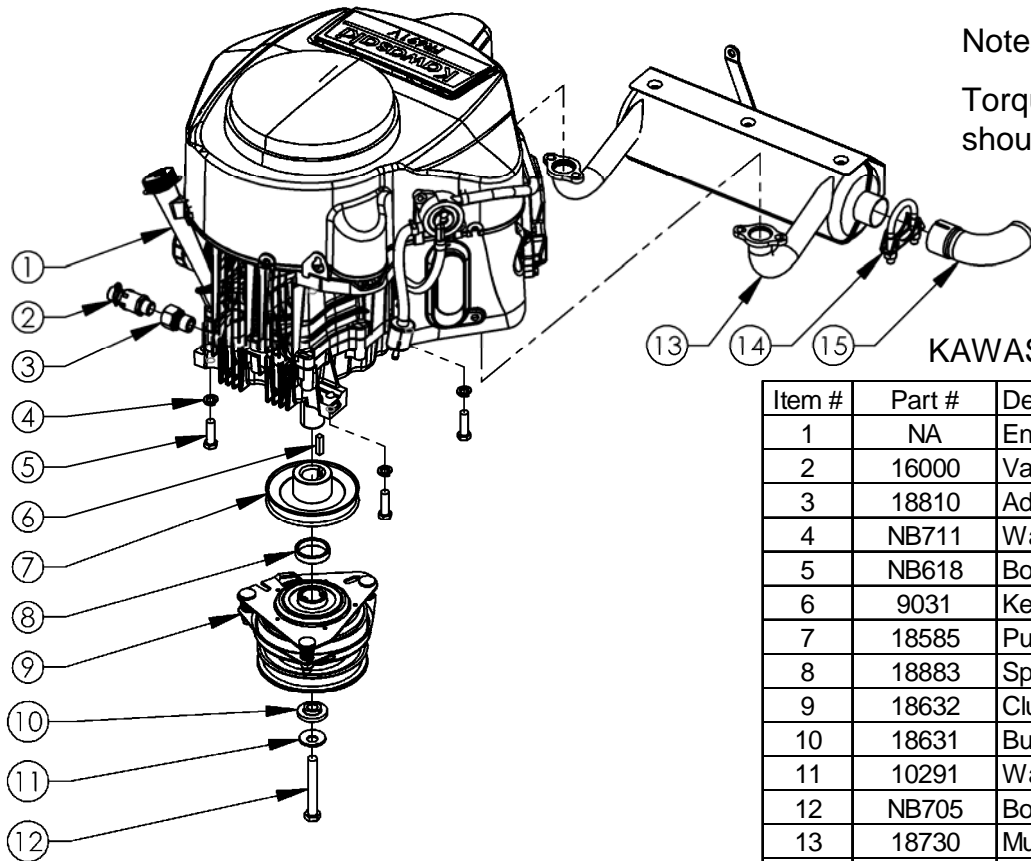

Notes:

Torque settings for bolt number 12 should be set at 20 ft./lbs.

KAWASAKI ENGINE DETAIL

Item #	Part #	Description	Qty.
1	NA	Engine - 24 HP Kawasaki	1
2	16000	Valve - Oil Drain	1
3	18810	Adapter - Oil Drain	1
4	NB711	Washer - Split Lock, 3/8	4
5	NB618	Bolt - 3/8-16 X 1 1/4	4
6	9031	Key Stock - 1/4 X 1	1
7	18585	Pulley - Engine	1
8	18883	Spacer - Clutch, Top	1
9	18632	Clutch - Ogura, 1" Shaft	1
10	18631	Bushing - Clutch, Ogura	1
11	10291	Washer - Belleville, .512 X 1.26 X .138	1
12	NB705	Bolt - HCF, 7/16-20 X 3.25	1
13	18730	Muffler - Kawasaki	1
14	18876	Clamp - Muffler	1
15	18853	Deflector - Muffler Turn Down, 90°	1

PARTS BREAKDOWN

HANDLE DETAIL

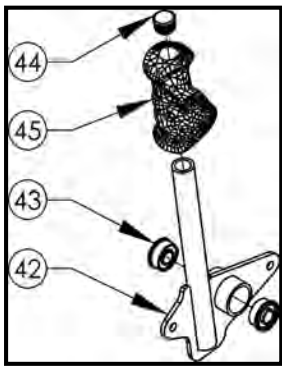

Notes:

-Item number 23 (two places) attaches to item number 8 from Page 3 using item numbers 29 & 30.

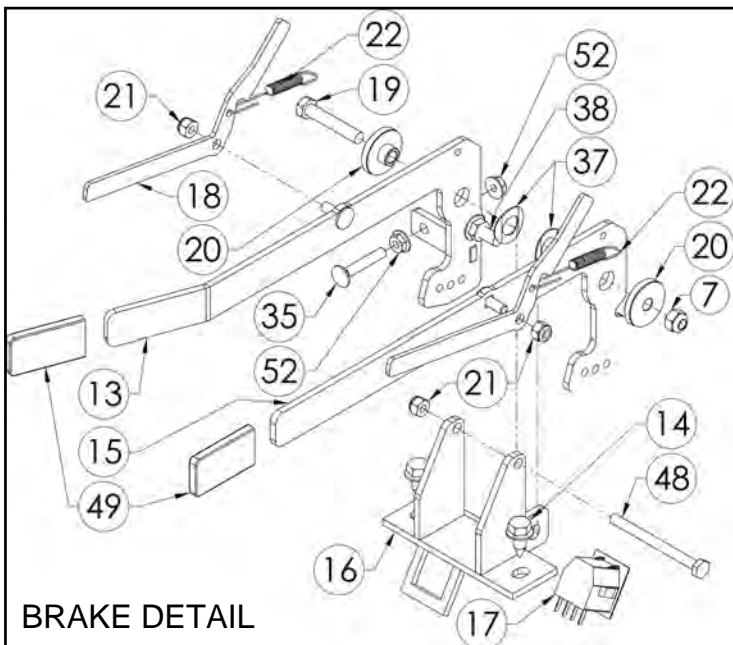
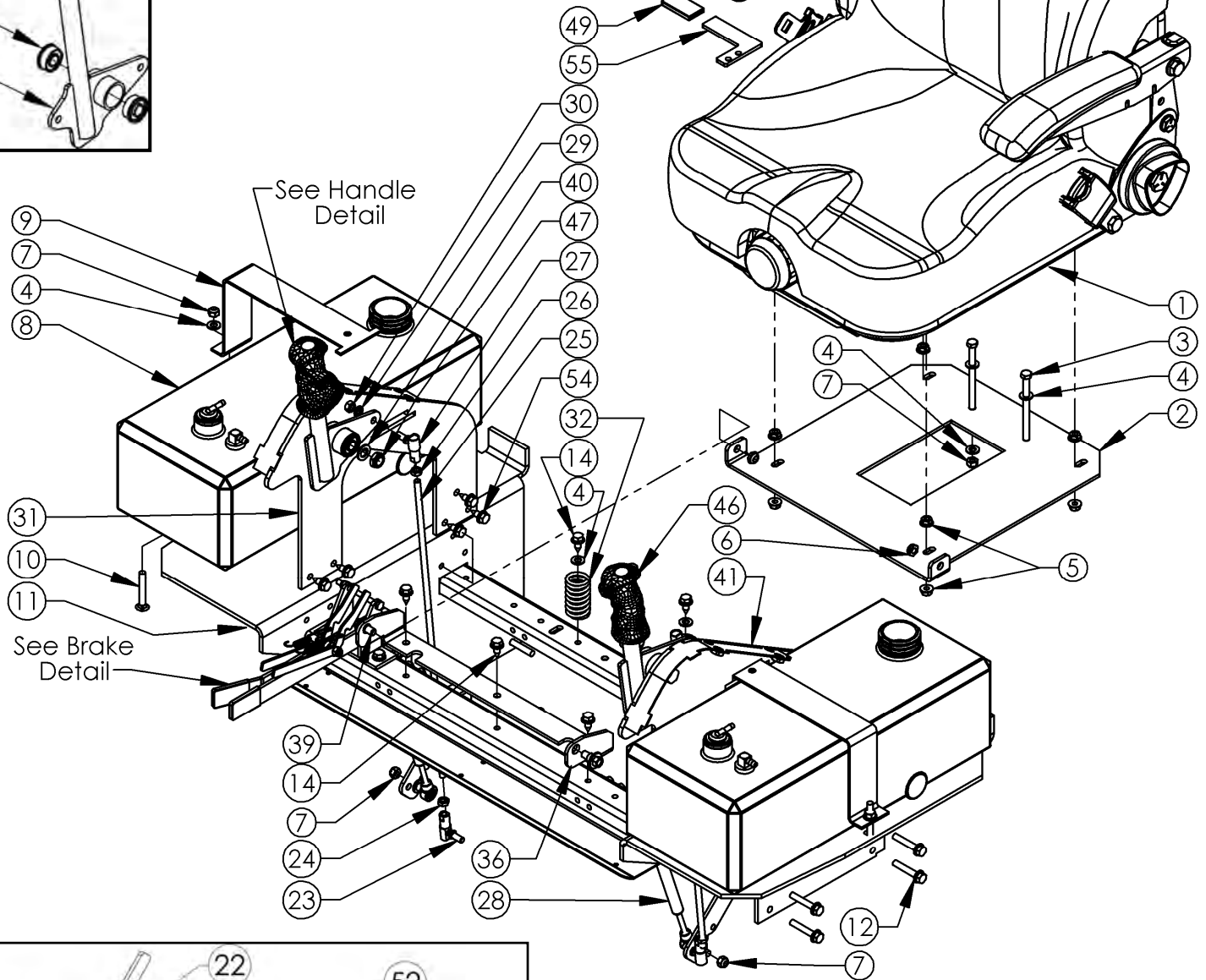

BRAKE DETAIL

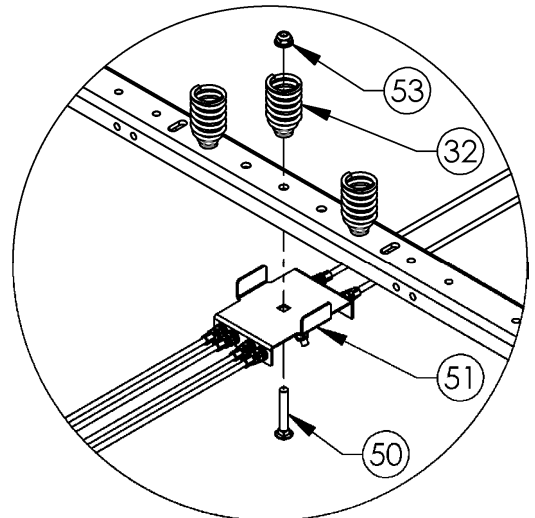

BRAKE & HYDRO BYPASS ASSEMBLY

PARTS BREAKDOWN

Item #	Part #	Description	Qty.
1	19367	Seat - Suspension, Armrest; Seatbelts	1
2	18679*	Base - Seat	1
3	NB513	Bolt - HCC, 5/16-18 x 4; GR5, ZY	2
4	NB275	Washer - SAE Flat, 5/16; ZY	5
5	NB170	Nut - Serr Flange, 5/16-18; Case Hard, ZY	15
6	NB207	Nut - Jam, Nyloc 3/8-16 ZY	2
7	NB181	Nut - Nyloc, 5/16-18; ZY	5
8	18582	Gas Tank - 4 Gallon, ZT	2
9	18686*	Strap - Tank Hold Down	2
10	NB110	Bolt - Carriage, 5/16-18 x 2 1/4; GR2, ZY	2
11	18713*	Weldment - Tank & Seat Mount	1
12	NB515	Bolt - Serr Flange 5/16-18 x 1 3/4; GR5, ZY	8
13	18931*	Weldment - Brake Arm	1
14	26X249	Screw - 5/16-18 x 3/4	9
15	18951*	Weldment - Bypass Arm	1
16	18936*	Weldment - Brake Mount Bracket	1
17	18945	Switch - 2 Pole, NC/NO	1
18	18933*	Plate - Swivel lock	2
19	NB503	Bolt - HCC, 5/16-18 x 1 3/4; GR5, ZP	1
20	14029	Bushing	2
21	NB180	Nut - Nyloc, 1/4-20	3
22	17465	Spring - Extension, Hydro Release, ZT	2
23	NB264	Linkage - Ball, Left; Moridge # 265616	2
24	NB265	Nut - Jam, 5/16-24; Left-Hand Thrd; GR2, ZY	2
25	18627	Linkage - 5/16-24 x 1; LHT & RHT	2
26	NB190	Nut - Jam, 5/16-24; GR2, ZY	2
27	NB263	Linkage - Ball, Right; Moridge # 265615	2
28	18723	Damper	2
29	NB159	Washer - Split Lock, 5/16; Medium Duty, ZY	4
30	NB215	Nut - Hex, 5/16-24; GR2, ZY	4
31	18710*	Weldment - Handle Mount, Right	1
32	3609	Spring - Tapered	3
33	18685*	Bracket - Damper Mount, Right (Hidden)	1
34	18687*	Bracket - Damper Mount, Left (Hidden)	1
35	NB583	Bolt - Carriage, 1/4-20 x 1 1/2; GR2, ZY	1
36	18680*	Bracket - Seat Swivel	1
37	18937	Washer - Wave, 1/2 ID x 1 OD x .087	2
38	10548	Bolt - Serr Flange, 5/16-18 x 1; GR5, ZY	1
39	009X58	Bolt - Shoulder, 3/8-16	2
40	NB177	Washer - Mach, 1/2 x 14 GA; NR	2
41	18711*	Weldment - Handle Mount, Left	1
42	18712*	Weldment - Handle; Txt Blk	2
43	MWB	Bearing - Wheel, 1 1/8" OD x 1/2" ID	4
44	18852	Plug - Plastic, 7/8 OD x 11 GA Tube; Blk	2
45	18807	Grip - Hand Conforming, Right	1
46	18808	Grip - Hand Conforming, Left	1
47	NB688	Nut - Nyloc Jam, 1/2-13; ZY	2
48	NB574	Bolt - 1/4-20 x 3; GR2, ZP	1
49	2077	Pivot - Handle Grip	3
50	NB590	Bolt - Carriage, 5/16-18 X 2	1
51	20103	Assembly - Brake & Hydro Bypass	1
52	NB524	Nut - Serr Flange, 1/4-20 Grade 5 ZY	2
53	20105	Nut - Flange 5/16-18, Nyloc	1
54	20235	Screw - Serr Flng 5/16-18X3/4, Type F ZP	10
55	20396*	Handle - Seat Adjustment	1

When ordering replacement parts

*USE PAINT CODE: TK=BLACK

PARTS BREAKDOWN

Z21554CPHO, Z21554CPHO-CA

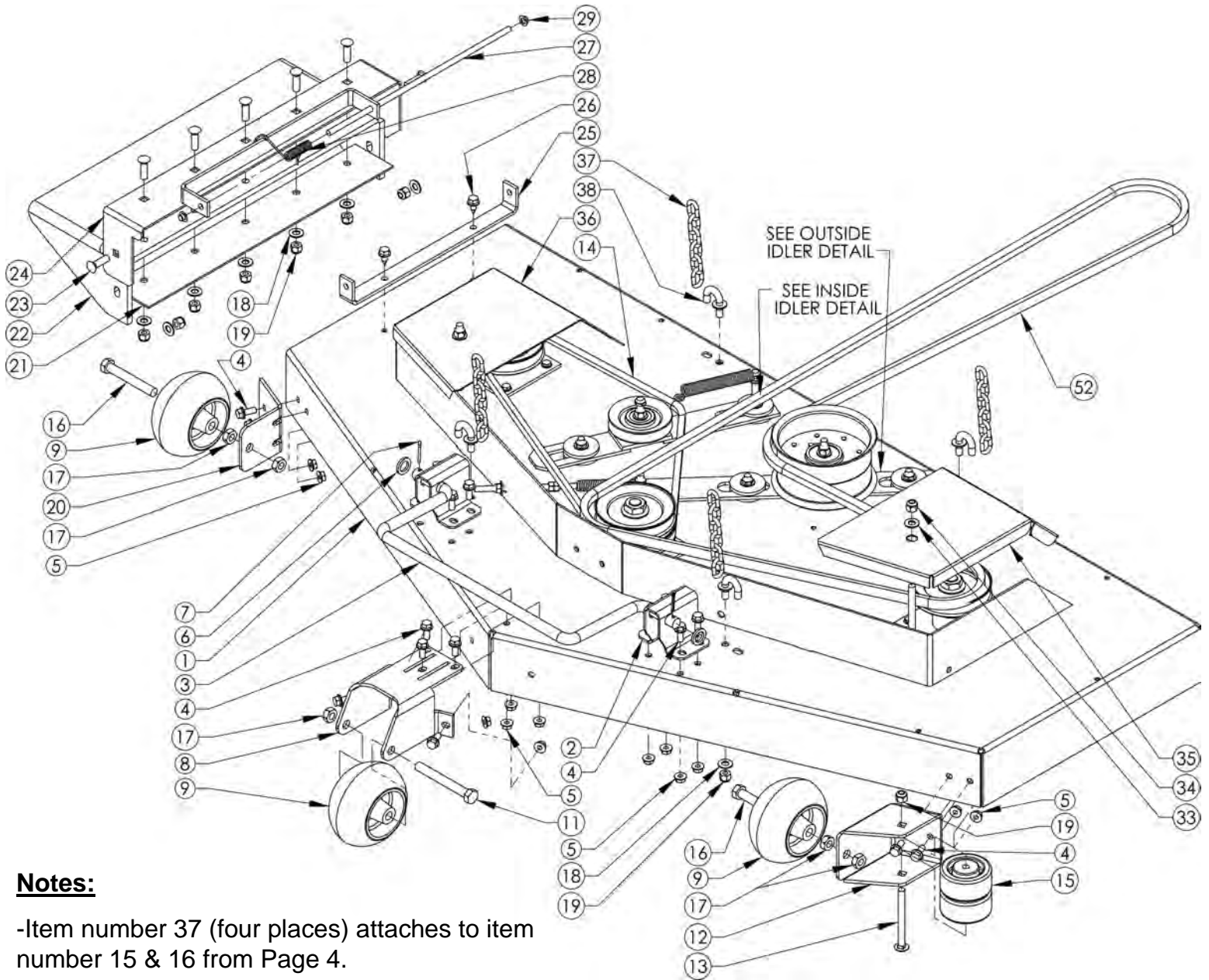

Notes:

-Item number 37 (four places) attaches to item number 15 & 16 from Page 4.

-Item number 3 attaches to item number 2 from Page 2 using item numbers 23, 24 & 25 from Page 4.

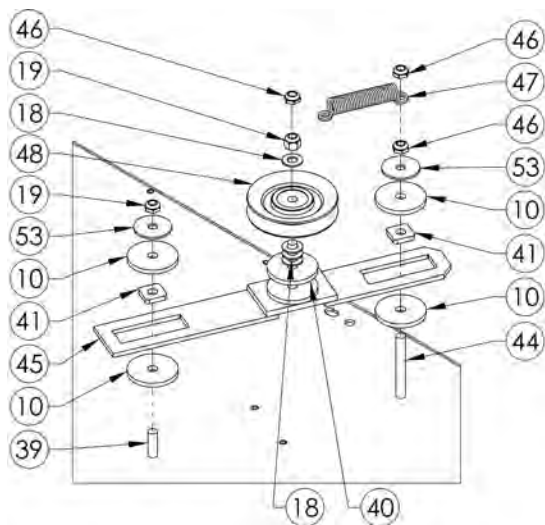

INSIDE IDLER DETAIL

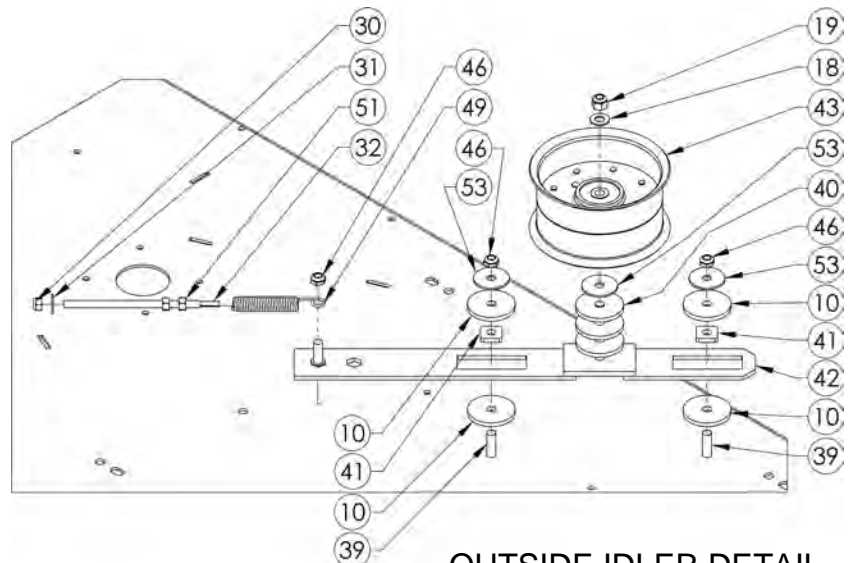

OUTSIDE IDLER DETAIL

PARTS BREAKDOWN

Z21554CPHO, Z21554CPHO-CA

Item #	Part #	Description	Qty.
1	18703*	Weldment - 54" Deck	1
2	18863*	Bracket - Stabilizer, 54" Deck	2
3	18601	Rod - Drag Link Bar	1
4	NB596	Bolt - Serr Flange, 5/16-18 x 3/4; GR5, ZY	17
5	NB170	Nut - Serr Flange, 5/16-18; Case Hard, ZY	19
6	NB178	Washer - 5/8" ID x 1" OD x 10 GA; ZY	2
7	NB126	Pin - Cotter, 1/8 x 1"; Carbon Steel, Ext Pmg	2
8	18383*	Bracket - Middle Roller	1
9	3511	Gauge - Wheel	3
10	18874	Washer - UHMW, 2" OD x 3/8" ID x .188"	8
11	NB132	Bolt - Hex, 1/2-13 x 4; GR5	1
12	15779*	Bracket - Left Wheel	1
13	NB707	Bolt - Carriage, 3/8-16 x 4; Full Thread, GR2	1
14	18638	Belt - Deck Idler, 1/2" x 54"	1
15	AS001	Roller - Anti-Scalp, 3/8 ID	2
16	NB577	Bolt - 1/2-13 x 3 1/2; GR5, ZY	2
17	NB121	Nut - Jam Lock, 1/2-13; 2-way, GR A	5
18	NB272	Washer - SAE Flat, 3/8; Carbon Steel, ZY	20
19	NB182	Nut - Nyloc, 3/8-16; ZY	14
20	15780*	Bracket - Anti-Scalp	1
21	18652*	Bracket - Grass Chute	1
22	18604	Rubber - Grass Chute	1
23	10501	Bolt - Carriage, 3/8-16 x 1 1/4; GR5, ZY	7
24	18702*	Weldment - Grass Chute	1
25	18654*	Bracket - Grass Chute Mount	1
26	26X249	Screw - 5/16-18 x 3/4	2
27	18595	Rod - Deck, Grass Chute; ZP	1
28	166X34	Spring - Torsion	1
29	NB117	Nut - Push, 5/16; ZP	2
30	NB181	Nut - Nyloc, 5/16-18; ZY	1
31	NB275	Washer - SAE Flat, 5/16; ZY	1
32	18622	Bolt - Spade, 5/16-18; ZY	1
33	NB272	Nut - Nyloc 3/8-16 ZY	2
34	NB182	Washer - Fender 3/8 ZY Carbon Steel	2
35	18726*	Cover - Left, Belt 54"	1
36	18725*	Cover - Right, Belt 54"	1
37	18722	Chain - Deck Hanger, Six Links	4
38	18597	Bolt - Hook, 3/8-16	4
39	NB618	Bolt - 3/8-16 x 1 1/4; GR5, ZY	3
40	6040Z	Washer - Idler, ZP	9
41	18875	Spacer - UHMW, 7/8" Sq. x 3/8" ID x .200"	4
42	18873*	Weldment - Backside Idler, 54	1
43	18613	Pulley - 4 1/2" OD x 2 1/2"	1
44	NB164	Washer - 1 x 1 1/2 x 10 GA	1
45	18708*	Weldment - Deck Idler, Inside	1
46	NB207	Nut - Nyloc Jam, 3/8-16; ZY	7
47	18728	Spring - Deck Idler, Short; ZP	1
48	3622	Pulley - V, Idler; 3.54 OD x 3/8 ID	1
49	4422	Spring - Idler Tension, Bent Leg	1
50	NB779	Nut - Serr Flange, 3/8-16; ZY	1
51	NB210Z	Nut - HNC, 5/16-18; GR2, ZY	2
52	18787	Belt - Engine to Deck, 1/2 x 122, Gates	1
53	10177	Washer - Fender 3/8X1 1/2, Crbn Stl GR 2	5

When ordering replacement parts

*USE PAINT CODE: TK=BLACK

PARTS BREAKDOWN

Z21560CPHO, Z21560CPHO-CA, Z2460CPKA, Z2460CPKA-CA

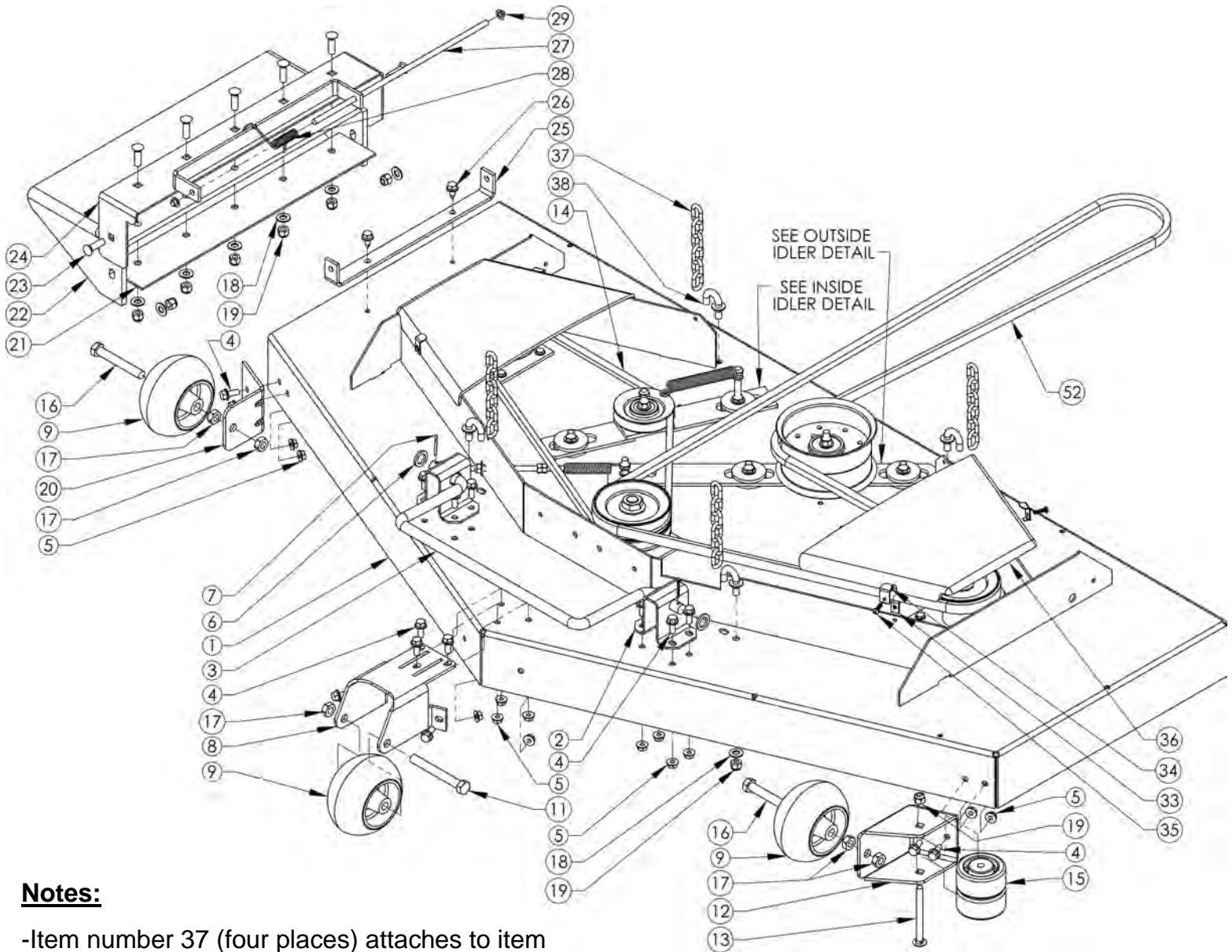

Notes:

-Item number 37 (four places) attaches to item number 15 & 16 from Page 4.

-Item number 3 attaches to item number 2 from Page 2 using item numbers 23, 24 & 25 from Page 4.

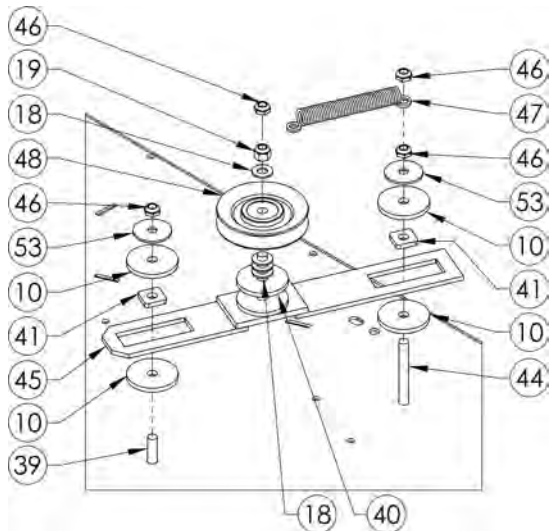

INSIDE IDLER DETAIL

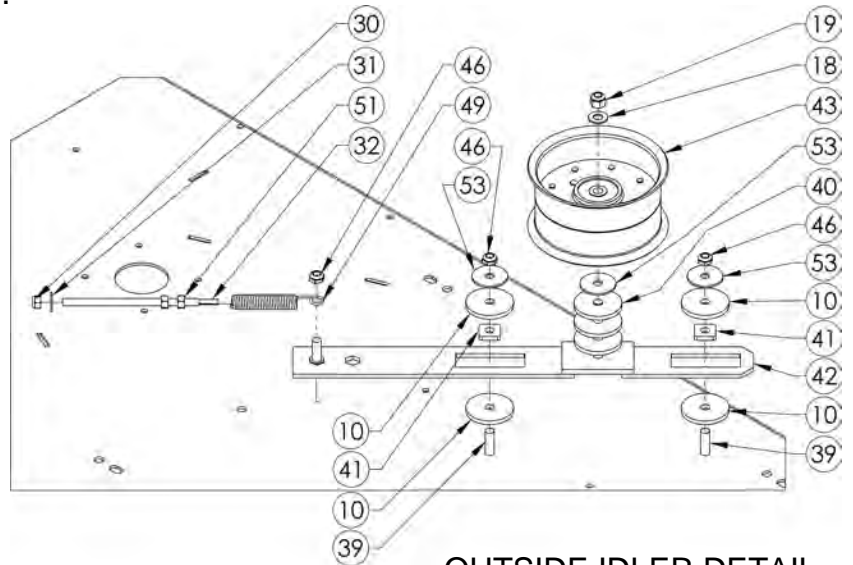

OUTSIDE IDLER DETAIL

PARTS BREAKDOWN

Z21560CPHO, Z21560CPHO-CA, Z2460CPKA, Z2460CPKA-CA

Item #	Part #	Description	Qty.
1	18701*	Weldment - 60" Deck	1
2	18786*	Bracket - Deck Stabilizer	2
3	18601	Rod - Drag Link Bar	1
4	NB596	Bolt - Serr Flange, 5/16-18 x 3/4; GR5, ZY	17
5	NB170	Nut - Serr Flange, 5/16-18; Case Hard, ZY	19
6	NB178	Washer - 5/8" ID x 1" OD x 10 GA; ZY	2
7	NB126	Pin - Cotter, 1/8 x 1"; Carbon Steel, Ext Prng	2
8	18383*	Bracket - Middle Roller	1
9	3511	Gauge - Wheel	3
10	18874	Washer - UHMW, 2" OD x 3/8" ID x .188"	8
11	NB132	Bolt - Hex, 1/2-13 x 4; GR5	1
12	15779*	Bracket - Left Wheel	1
13	NB707	Bolt - Carriage, 3/8-16 x 4; Full Thread, GR2	1
14	18637	Belt - Deck Idler, 1/2" x 55"	1
15	AS001	Roller - Anti-Scalp, 3/8 ID	2
16	NB577	Bolt - 1/2-13 x 3 1/2; GR5, ZY	2
17	NB121	Nut - Jam Lock, 1/2-13; 2-way, GR A	5
18	NB272	Washer - SAE Flat, 3/8; Carbon Steel, ZY	20
19	NB182	Nut - Nyloc, 3/8-16; ZY	14
20	15780*	Bracket - Anti-Scalp	1
21	18652*	Bracket - Grass Chute	1
22	18604	Rubber - Grass Chute	1
23	10501	Bolt - Carriage, 3/8-16 x 1 1/4; GR5, ZY	7
24	18702*	Weldment - Grass Chute	1
25	18654*	Bracket - Grass Chute Mount	1
26	26X249	Screw - 5/16-18 x 3/4	2
27	18595	Rod - Deck, Grass Chute; ZP	1
28	166X34	Spring - Torsion	1
29	NB117	Nut - Push, 5/16; ZP	2
30	NB181	Nut - Nyloc, 5/16-18; ZY	1
31	NB275	Washer - SAE Flat, 5/16; ZY	1
32	18622	Bolt - Spade, 5/16-18; ZY	1
33	18532	Nut - Clip, 10-24	4
34	18531	Washer - Bent, 1/4" ID x 18 GA; Belt Cover	4
35	024203	Screw - Phillips Truss Head, 10-34; ZP	4
36	18621	Cover - Deck Belt, Short	2
37	18722	Chain - Deck Hanger, Six Links	4
38	18597	Bolt - Hook, 3/8-16	4
39	NB618	Bolt - 3/8-16 x 1 1/4; GR5, ZY	3
40	6040Z	Washer - Idler, ZP	9
41	18875	Spacer - UHMW, 7/8" Sq. x 3/8" ID x .200"	4
42	18707*	Weldment - deck Idler, Backside	1
43	18613	Pulley - 4 1/2" OD x 2 1/2"	1
44	NB164	Washer - 1 x 1 1/2 x 10 GA	1
45	18708*	Weldment - Deck Idler, Inside	1
46	NB207	Nut - Nyloc Jam, 3/8-16; ZY	7
47	18605	Spring - Extension, Idler; ZP	1
48	3622	Pulley - V, Idler; 3.54 OD x 3/8 ID	1
49	4422	Spring - Idler Tension, Bent Leg	1
50	NB779	Nut - Serr Flange, 3/8-16; ZY	1
51	NB210Z	Nut - HNC, 5/16-18; GR2, ZY	2
52	18746	Belt - Engine to Deck, 1/2 x 126, Gates	1
53	10177	Washer - Fender 3/8X1 1/2, Crbn Stl GR 2	5

When ordering replacement parts

*USE PAINT CODE: TK=BLACK

PARTS BREAKDOWN

Z2466CPKA, Z2466CPKA-CA

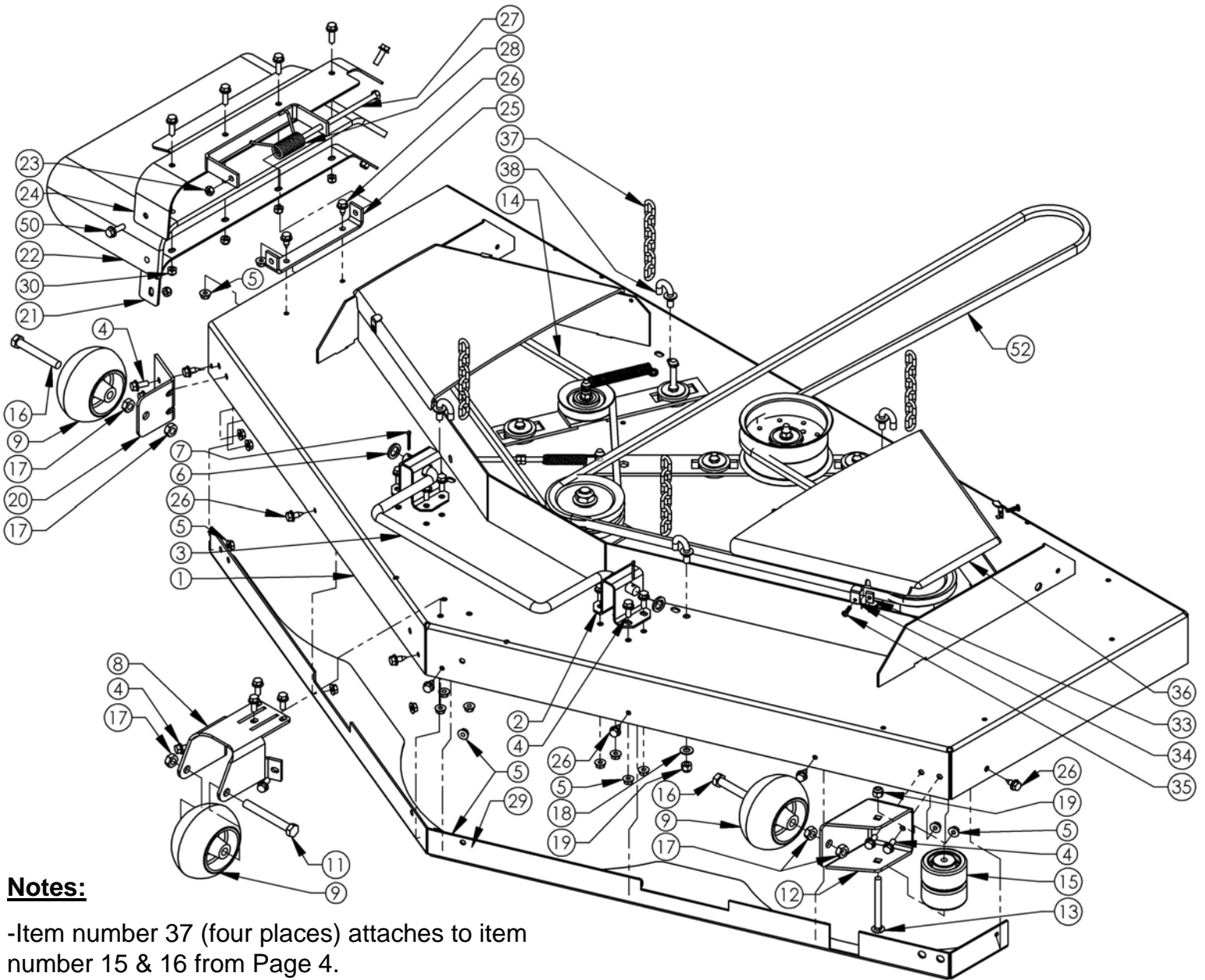

Notes:

-Item number 37 (four places) attaches to item number 15 & 16 from Page 4.

-Item number 3 attaches to item number 2 from Page 2 using item numbers 23, 24 & 25 from Page 4.

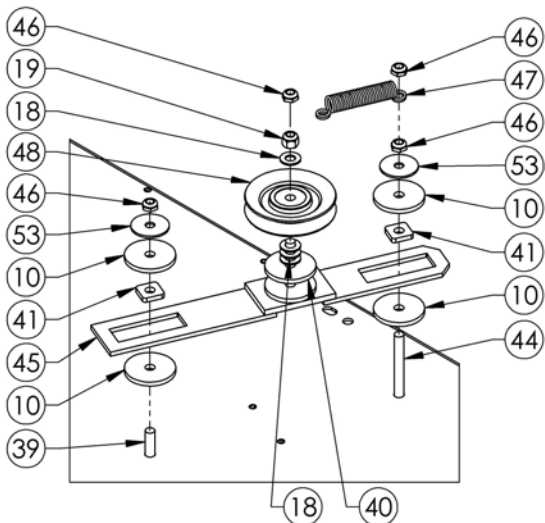

INSIDE IDLER DETAIL

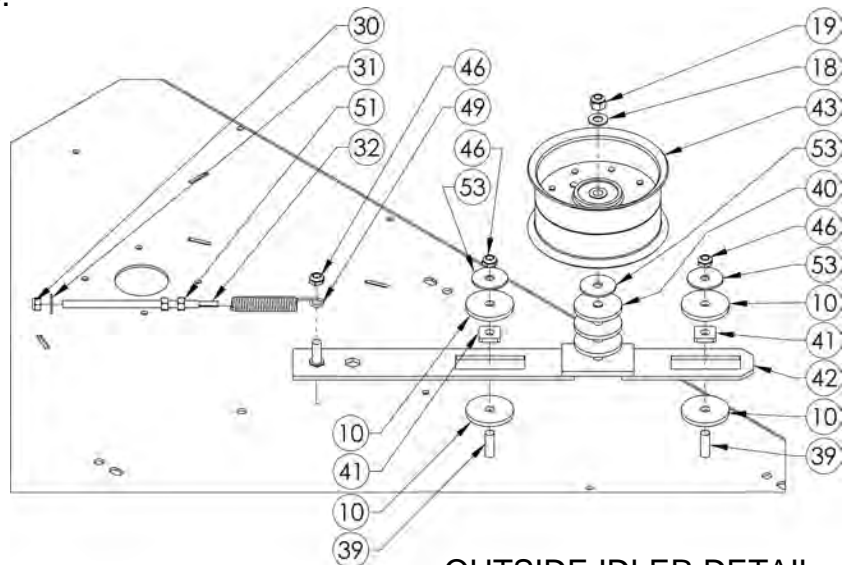

OUTSIDE IDLER DETAIL

PARTS BREAKDOWN

Z2466CPKA, Z2466CPKA-CA

Item #	Part #	Description	Qty.
1	19064*	Weldment - 66" deck; Txt Blk	1
2	18786*	Bracket - Deck Stabilizer; Txt Blk	2
3	18601	Rod - Drag Link Bar	1
4	NB596	Bolt - Serr Flange, 5/16-18 x 3/4; GR5, ZY	17
5	NB170	Nut - Serr Flange, 5/16-18; Case Hard, ZY	19
6	NB178	Washer - 5/8" ID x 1" OD x 10 GA; ZY	2
7	NB126	Pin - Cotter, 1/8 x 1"; Carbon Steel, Ext Pmg	2
8	18383*	Bracket - Middle Toller; Txt Blk	1
9	3511	Gauge - Wheel	3
10	18874	Washer - UHMW, 2" OD x 3/8" ID x .188"	8
11	NB132	Bolt - Hex, 1/2-13 x 4; GR5	1
12	15779*	Bracket - Left Wheel; Txt Blk	1
13	NB707	Bolt - Carriage, 3/8-16 x 4; Full Thread, GR2	1
14	19070	Belt - Deck Idler, 1/2" x 62"	1
15	AS001	Roller - Anti-Scalp, 3/8 ID	2
16	NB577	Bolt - 1/2-13 x 3 1/2; GR5, ZY	2
17	NB121	Nut - Jam Lock, 1/2-13; 2-way, GR A	5
18	NB272	Washer - SAE Flat, 3/8; Carbon Steel, ZY	5
19	NB182	Nut - Nyloc, 3/8-16; ZY	7
20	15780*	Bracket - Anti-Scalp; Txt Blk	1
21	14256*	Bracket - Grass Chute; Txt Blk	1
22	14258	Rubber - Grass Chute	1
23	NB558	Nut - 2-Way Lock, 5/16-18; ZY	2
24	14434*	Weldment - Grass Chute; Txt Blk	1
25	6030*	Bracket - Grass Chute Mount; Txt Blk	1
26	26X249	Screw - 5/16-18 x 3/4	9
27	NB136	Rod - 5/16-18 X 8 3/4; ZP	1
28	166X34	Spring - Torsion	1
29	19067*	Plate - Debris Shield, 66"; Txt Blk	1
30	NB181	Nut - Nyloc, 5/16-18; ZY	7
31	NB275	Washer - SAE Flat, 5/16; ZY	1
32	18622	Bolt - Spade, 5/16-18; ZY	1
33	18532	Nut - Clip, 10-24	4
34	18531	Washer - Bent, 1/4" ID x 18 GA; Belt Cover	4
35	024203	Screw - Phillips Truss Head, 10-34; ZP	4
36	19068	Cover - Deck Belt, 66"	2
37	18722	Chain - Deck Hanger, Six Links	4
38	18597	Bolt - Hook, 3/8-16	4
39	NB618	Bolt - 3/8-16 x 1 1/4; GR5, ZY	3
40	6040Z	Washer - Idler, ZP	5
41	18875	Spacer - UHMW, 7/8" Sq. x 3/8" ID x .200"	4
42	18707*	Weldment - Deck Idler, Backside; Txt Blk	1
43	18613	Pulley - 4 1/2" OD x 2 1/2"	1
44	NB164	Bolt - HTC 3/8-16 x 3; GR5 (Full Thread)	1
45	18708*	Weldment - Deck Idler, Inside; Txt Blk	1
46	NB207	Nut - Nyloc Jam, 3/8-16; ZY	6
47	18728	Spring - Idler, Short; ZP	1
48	3622	Pulley - V, Idler; 3.54 OD x 3/8 ID	1
49	4422	Spring - Idler Tension, Bent Leg	1
50	10548	Bolt - Serr Flange, 5/16-18 x 1; GR5	6
51	NB210Z	Nut - HNC, 5/16-18; GR2, ZY	2
52	19069	Belt - Engine to Deck, 1/2 x 130, Gates	1
53	10177	Washer - Fender 3/8X1 1/2, Crbn Stl GR 2	5

When ordering replacement parts

*USE PAINT CODE: TK=BLACK

PARTS BREAKDOWN

CENTER BLADE DRIVER

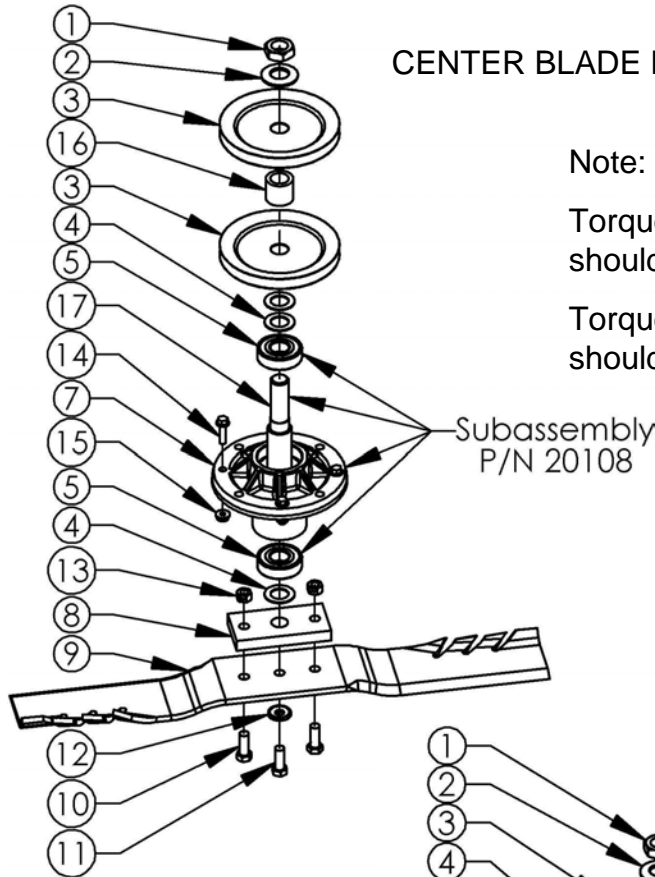

Note:

Torques for bolt numbers 10 & 11 should be set at 35 ft./lbs.

Torque settings for nut number 1 should be set at 35 ft./lbs.

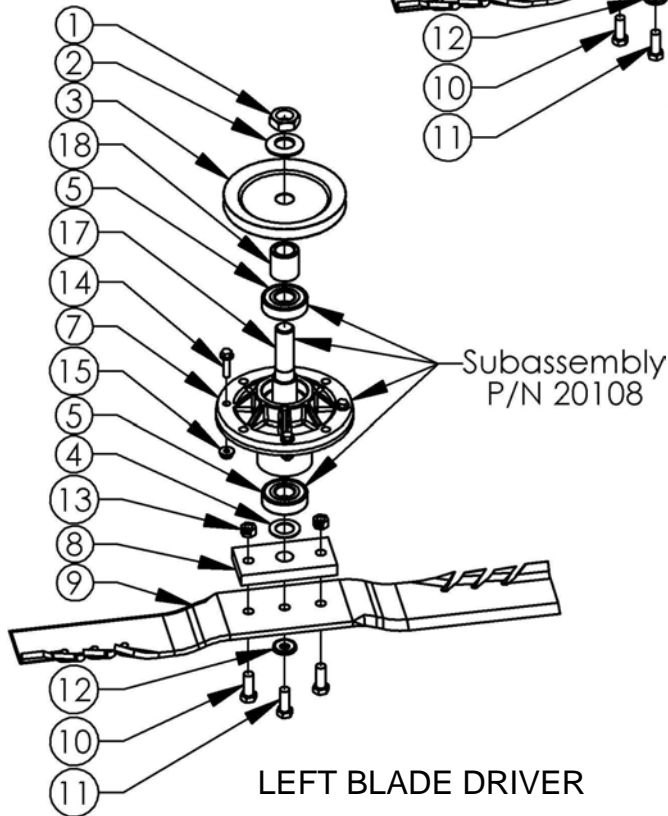

LEFT BLADE DRIVER

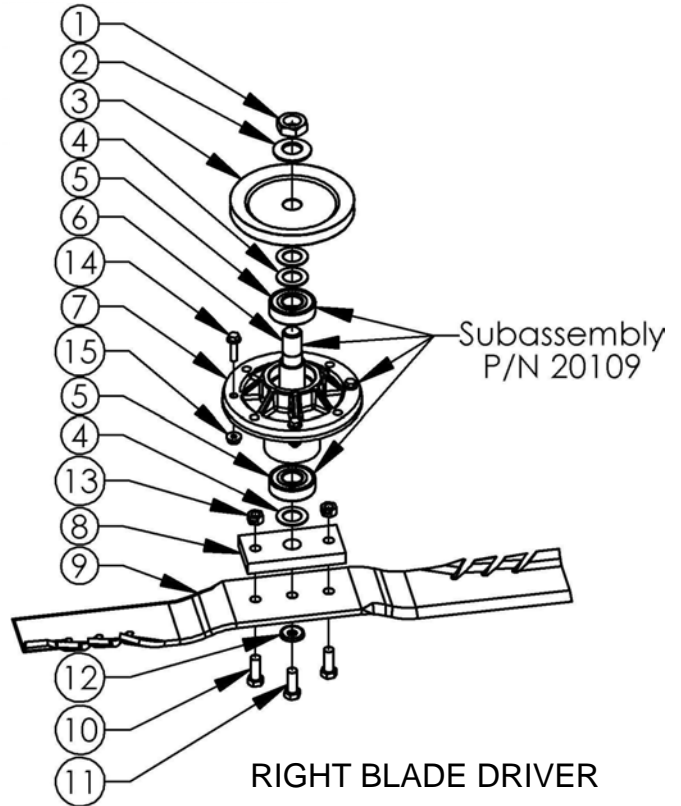

RIGHT BLADE DRIVER

Item #	Part #	Description	Qty.
1	NB175	Nut - Jam, 3/4-16; GR2	3
2	AS155	Washer - Belleville, 3/4 x 1 1/2 x .098	3
3	B4104*	Pulley - Blade 4.5" (54" & 60" Decks)	4
	3785	Pulley - Blade 5" (66" Deck)	4
4	NB179	3/4 ID X 1 1/4 OD 18 GA Washer	7
5	B98	Bearing - Blade	6
6	9077	Shaft - Blade 5", Long Shoulder	1
7	19924*	Blade Driver - Cast Iron Txt Blk	3
8	9008	Plate - Blade Mount	3

Item #	Part #	Description	Qty.
9	20667	Blade - G6 Gator, 18.5" (54" Deck)	3
	20186	Blade - G6 Gator, 20.5" (60" Deck)	3
	20115	Blade - G6 Gator, 22.5" (66" Deck)	3
10	NB166	Bolt - 3/8-24 x 1 1/4; GR5, ZY	6
11	NB238N	Bolt - HHc, 3/8-24 x 1; GR5, Nyloc	3
12	NB607	Washer - SP Belleville, .413 x .945 x .118	3
13	NB216	Nut - Two Way Lock, 3/8-24; GR A, ZY	6
14	13182	Bolt - Serr Flange, 1/4-20 x 1; GR5	12
15	NB524	Nut - Serr Flange, 1/4-20; Case Hard, ZY	12
16	12823	Spacer - 3/4 ID x 1, Powder Metal	1
17	9078	Shaft - Blade 6", Long Shoulder	2
18	18620	Spacer - Pulley, Deck Idler	1

When ordering replacement parts

*USE PAINT CODE: TK=BLACK

PARTS BREAKDOWN

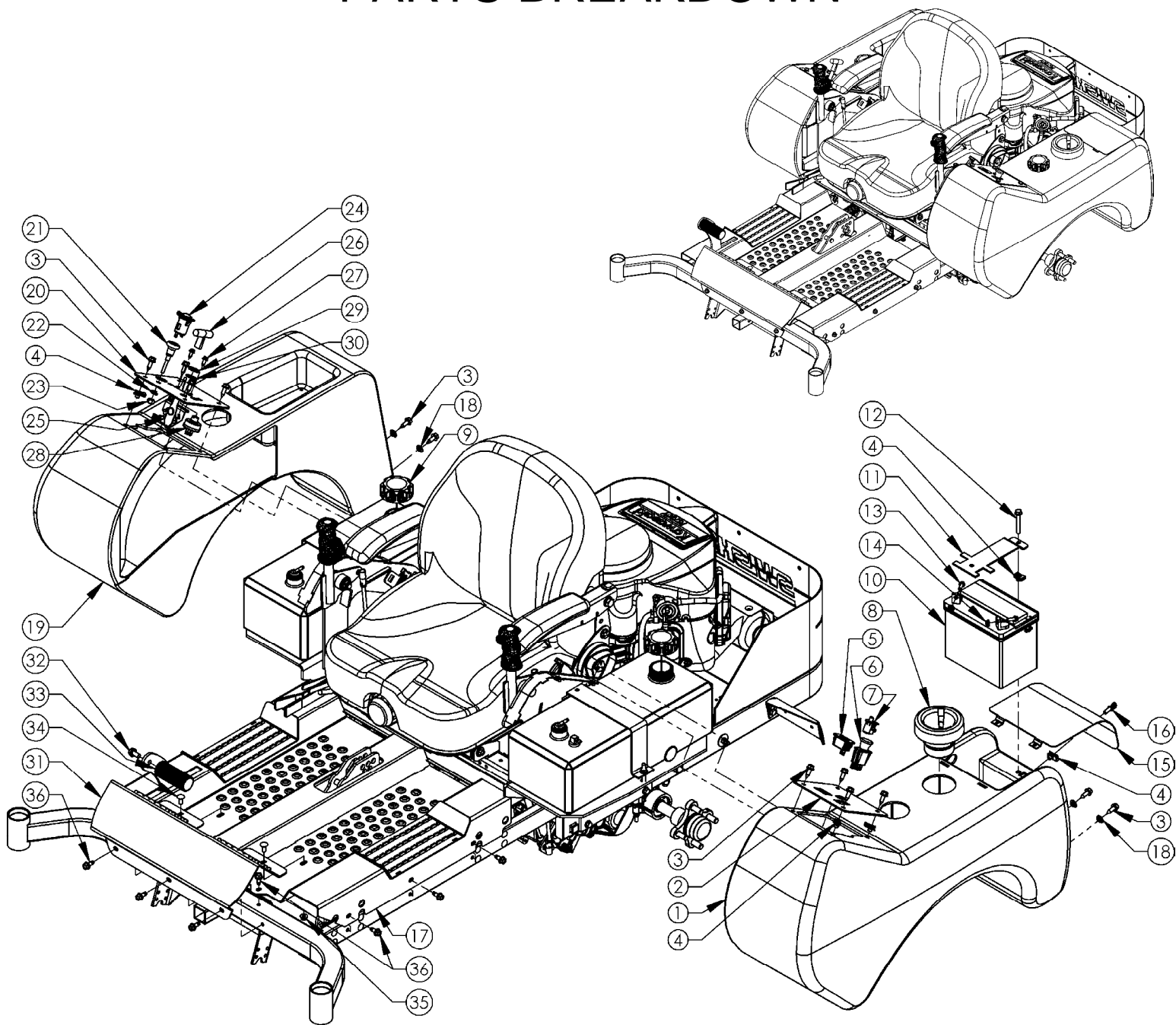

Item #	Part #	Description	Qty.
1	20433	Fender - Left	1
2	18578*	Panel - Control, Left	1
3	18743	Screw - Thread Cut, 5/16-18X1	12
4	3706	Clip - Timmerman, 5/16-18	6
5	17635	Hour Meter - LCD	1
6	3605	Switch - PTO	1
7	18636	Switch - Starter	1
8	1001542	Holder - GA, Beverage	1
9	18221	Cap, Fuel - 2.5 Gallon, Carb Sealed	2
10	EBAT300	Battery - 12V (8U1L)	1
11	18698*	Strap - Battery Hold Down	1
12	NB622	Bolt - Serr Flange, 5/16-18 x 2 1/4; GR5, ZY	1
13	NB690	Bolt - Serr Flange, 1/4-20 x 3/4; GR5, ZY	2
14	NB524	Nut - Serr Flange, 1/4-20; GR5, ZY	2
15	18697*	Cover - Battery, Fender	1
16	18802	Screw - Thumb w/ Shoulder, 5/16-18 x 3/4	1
17	20636*	Weldment - Floorpan	1
18	18717	Spacer - Fender	4

Item #	Part #	Description	Qty.
19	20432	Fender - Right	1
20	18639*	Panel - Control, Right	1
21	18606	Cable - Choke 66" (Kawasaki Models)	1
	19170	Cable - Choke 52" (Honda Models)	1
22	NB711	Washer - Split Lock, 3/8; Medium, ZY	1
23	NB456	Nut - HNF, 3/8-24; GR2, ZY	1
24	18745	Adapter - 12V Power Plug	1
25	4226	Cable - Throttle	1
26	4226K	Knob - T, for Throttle Cable	1
27	26X263	Screw - 1/4-20 x 1/2	2
28	3623	Switch - Key	1
29	9087	Nut - Key Switch	1
30	9088	Washer - Lock, Key Switch	1
31	20643*	Weldment - Foot Rest Bracket	1
32	NB780	Bolt - Serr Flange, 3/8-16 x 3/4; GR5, ZY	1
33	18603B	Bar - Foot Pedal, Black Oxide	1
34	20236	Bolt - Carriage 5/16-18 X .75	2
35	20237	Nut - Serr Flange 5/16-18	2
36	20235	Screw - Serr Flng 5/16-18X3/4	11

When ordering replacement parts

*USE PAINT CODE: TK=BLACK

PARTS BREAKDOWN

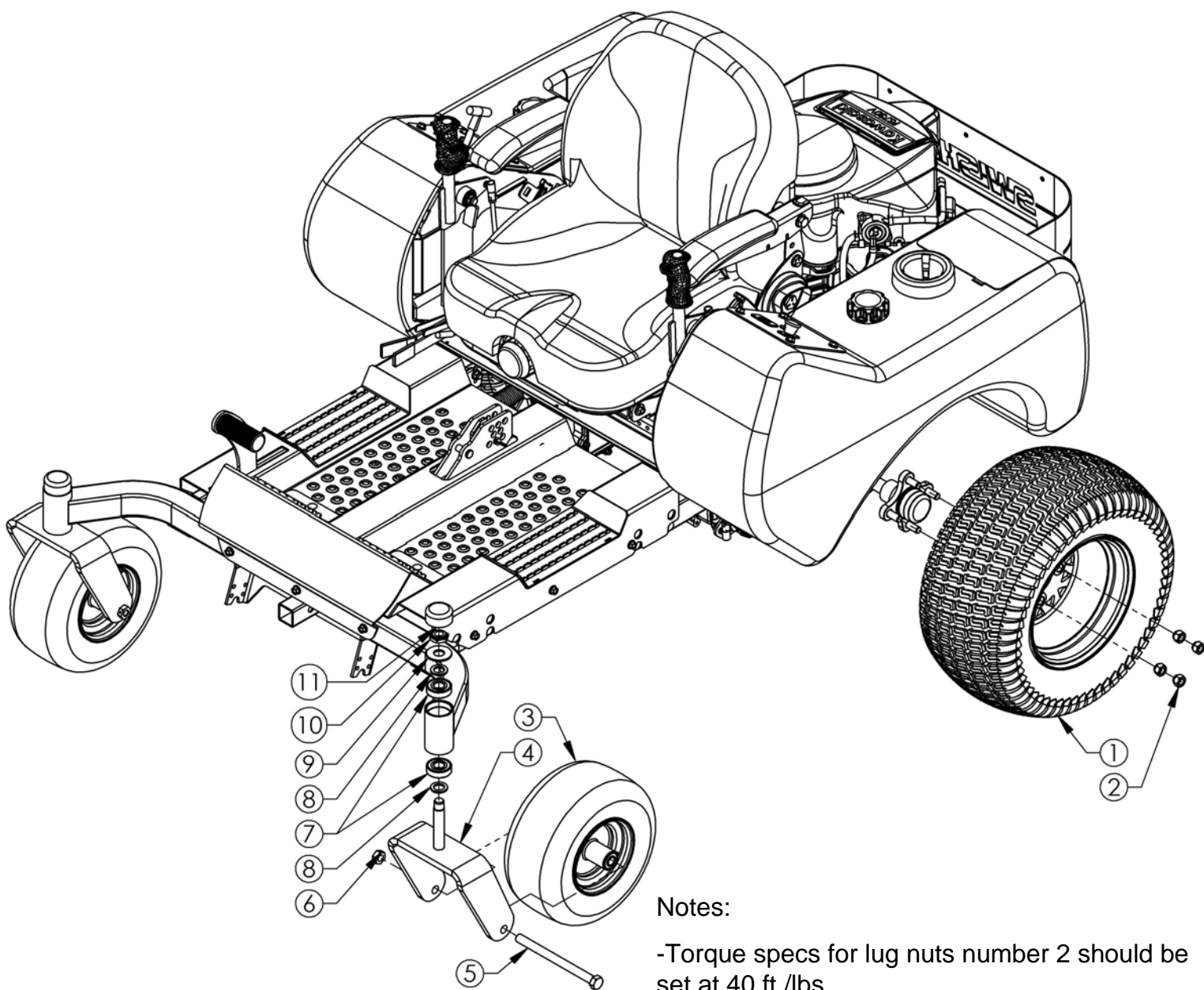

Notes:

-Torque specs for lug nuts number 2 should be set at 40 ft./lbs.

-Nut number 10 should not be fastened tightly. It should only be tight enough to engage the Nyloc nut but also allow the caster (#4) to spin freely. There should be no up and down axial movement in the caster once fastened.

-Bolt & nut numbers 5 & 6 should also not be fastened tightly. They should be tight enough that the bolt has no axial movement side to side but also allow the wheel (#3) to spin freely.

Item #	Part #	Description	Qty.
1	18784	Tire/Wheel - 20 x 10-10; Spoked, Blk	2
2	2203LN	Nut - Lug, Wheel Hub, 1/2-20; GR5, ZY	8
3	18785	Tire/Wheel - 12/600 x 6-4Ply; Smooth, Blk	2
4	18816*	Weldment - Caster, 3/8" (54" Deck)	2
	18886*	Weldment - Caster, 1/2" (60" & 66" Decks)	2
5	14430	Bolt - 5/8-11 x 8 (54" Deck)	2
	18953	Bolt - 5/8-11 X 8 1/2 (60" & 66" Decks)	2
6	NB595	Nut - 2-way Jam Lock, 5/8-11; GR A	2
7	B98	Bearing - Blade	4
8	NB195	Washer - 13/16 x 1 1/4 x 1/8; Mild, ZY	4
9	17X195	Washer - Flat	2
10	NB313	Nut - Myloc Jam, 3/4-10	2
11	094618	Cap - Hub	2

When ordering replacement parts

*USE PAINT CODE: TK=BLACK

WIRING HARNESS

RIGHT WIRING HARNESS P/N 18692

For models equipped with a Kawasaki Engine.

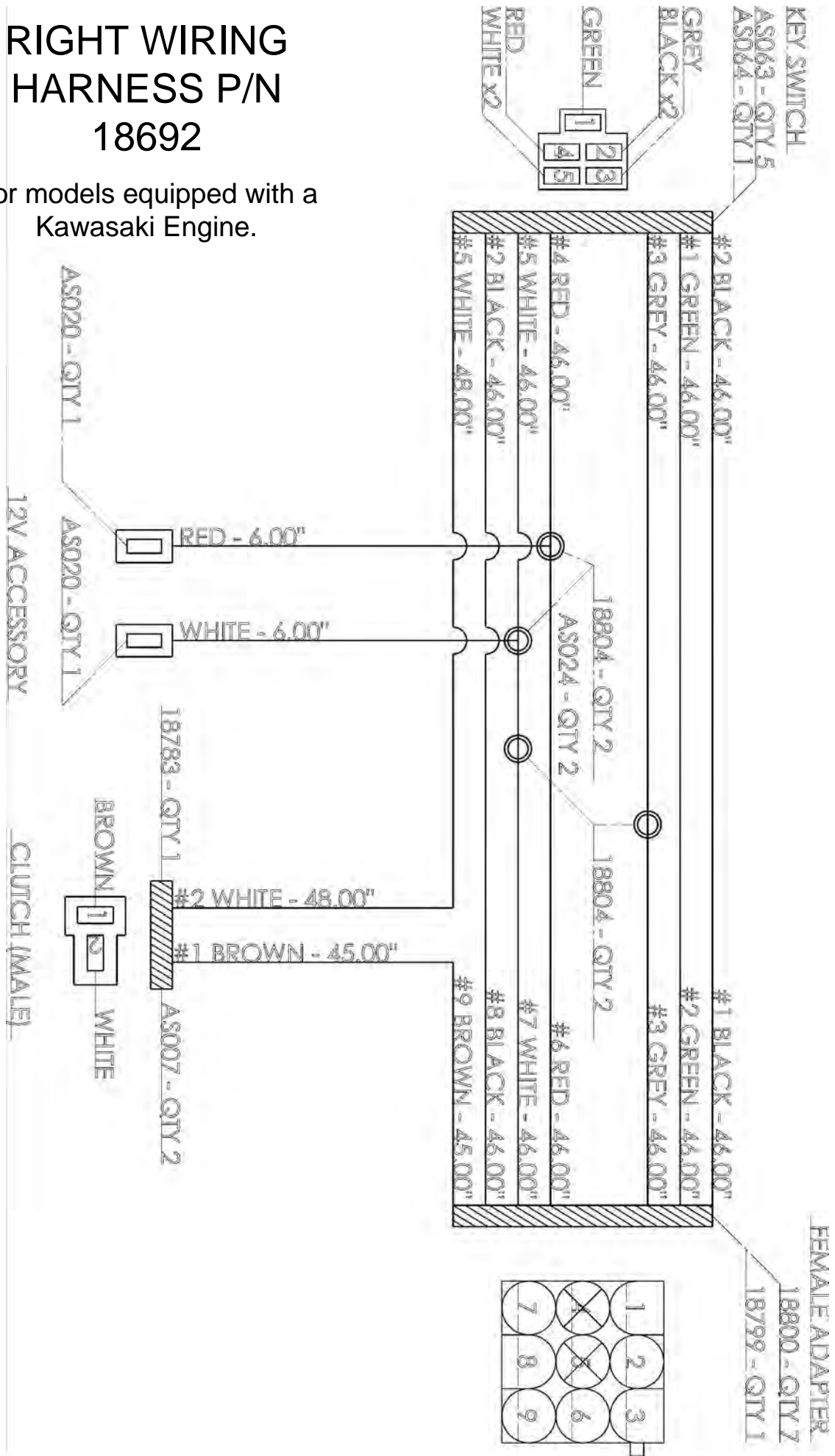

WIRING HARNESS

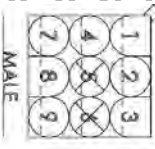

LEFT WIRING HARNESS P/N 18693

For models equipped with a Kawasaki Engine.

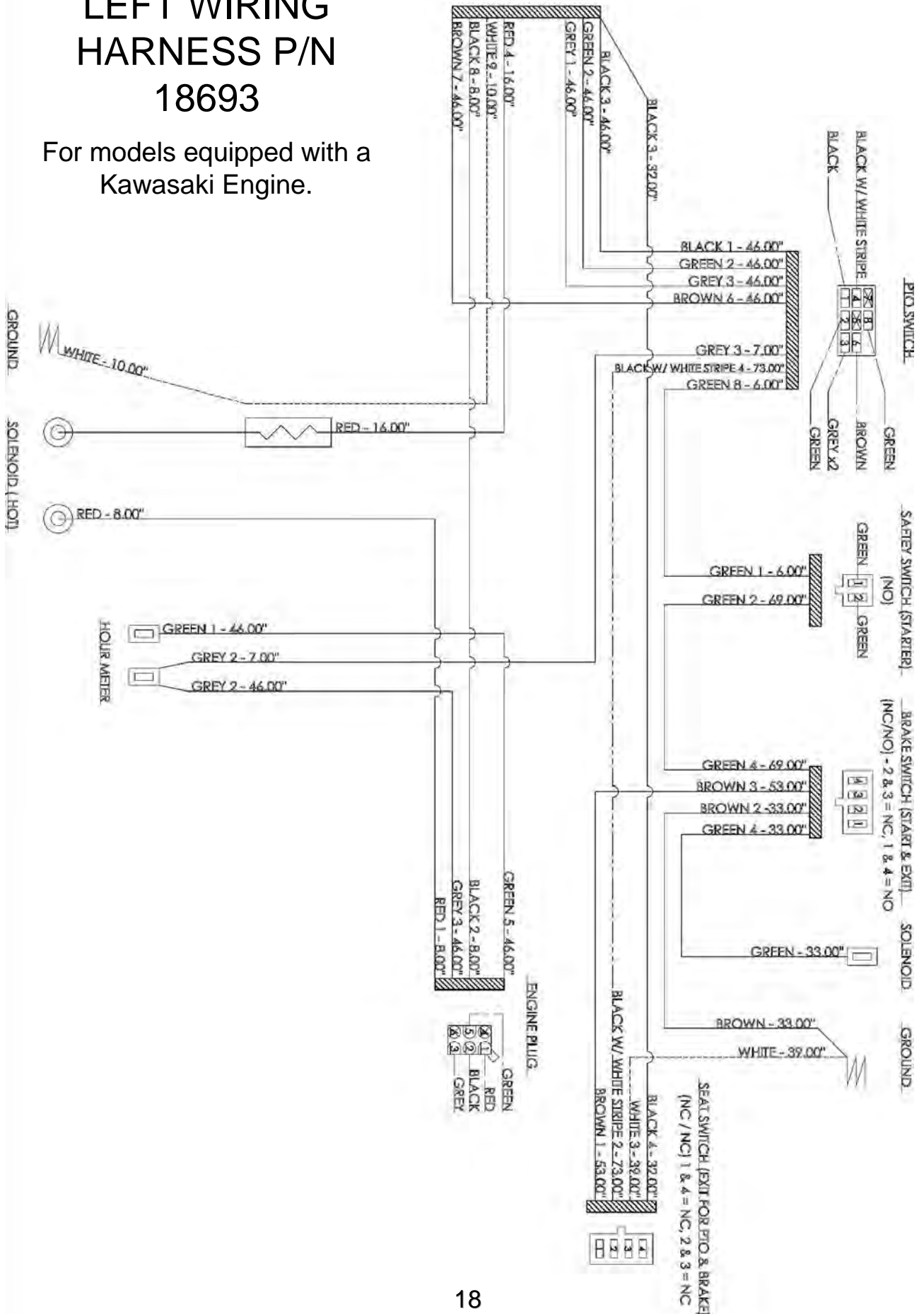

WIRING HARNESS

WIRING HARNESS P/N 18806

For models equipped with a
Kawasaki Engine.

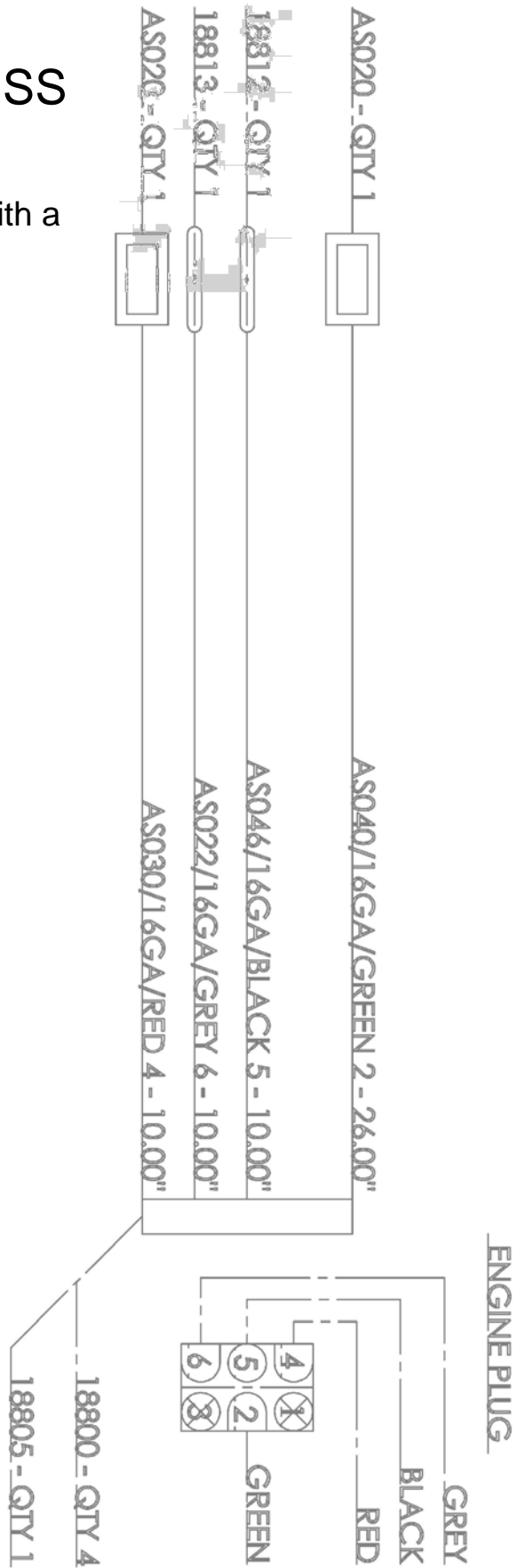

WIRING HARNESS

RIGHT WIRING HARNESS P/N 20945

For models equipped with a Honda Engine.

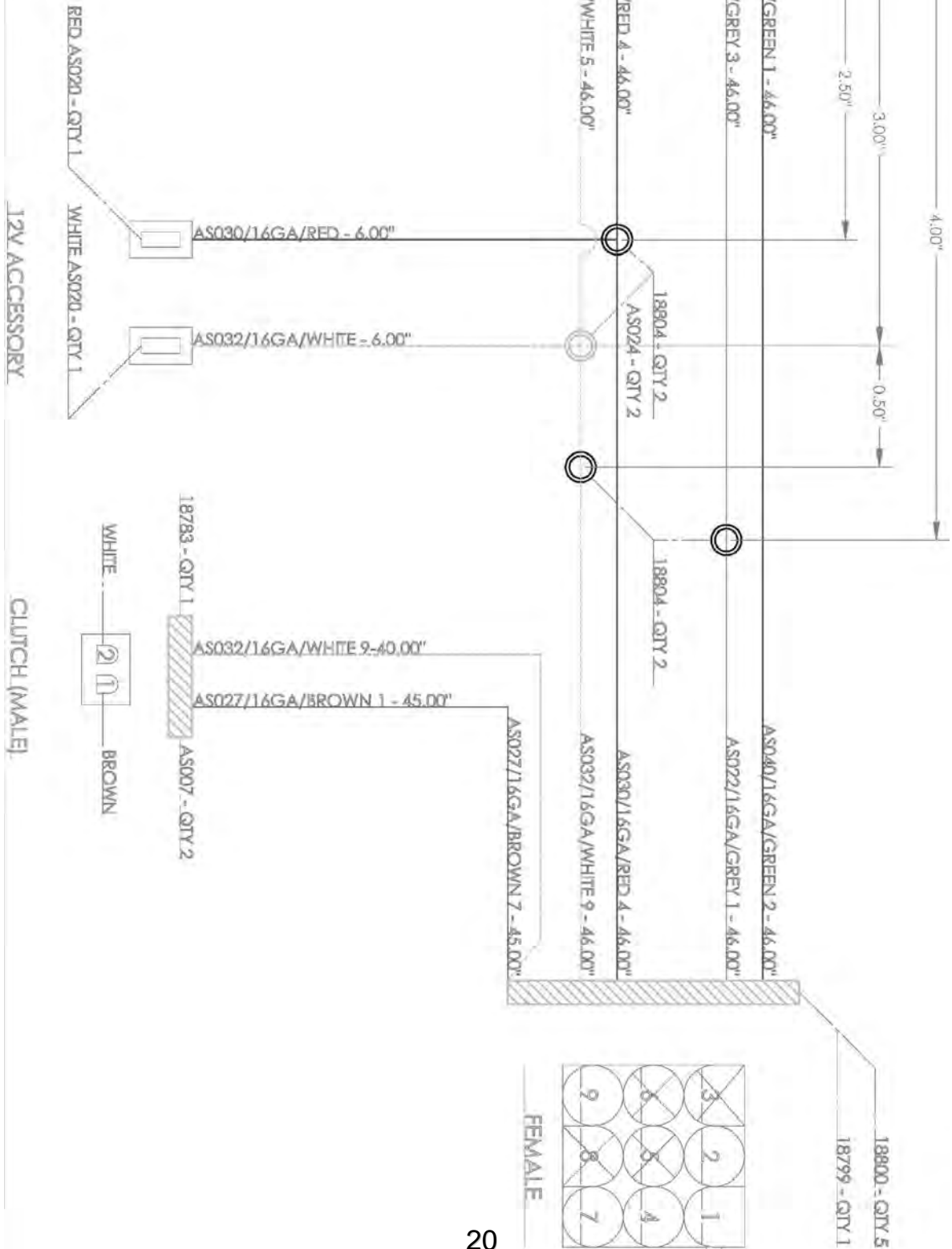

WIRING HARNESS

LEFT WIRING HARNESS P/N 20944

For models equipped with a Honda Engine.

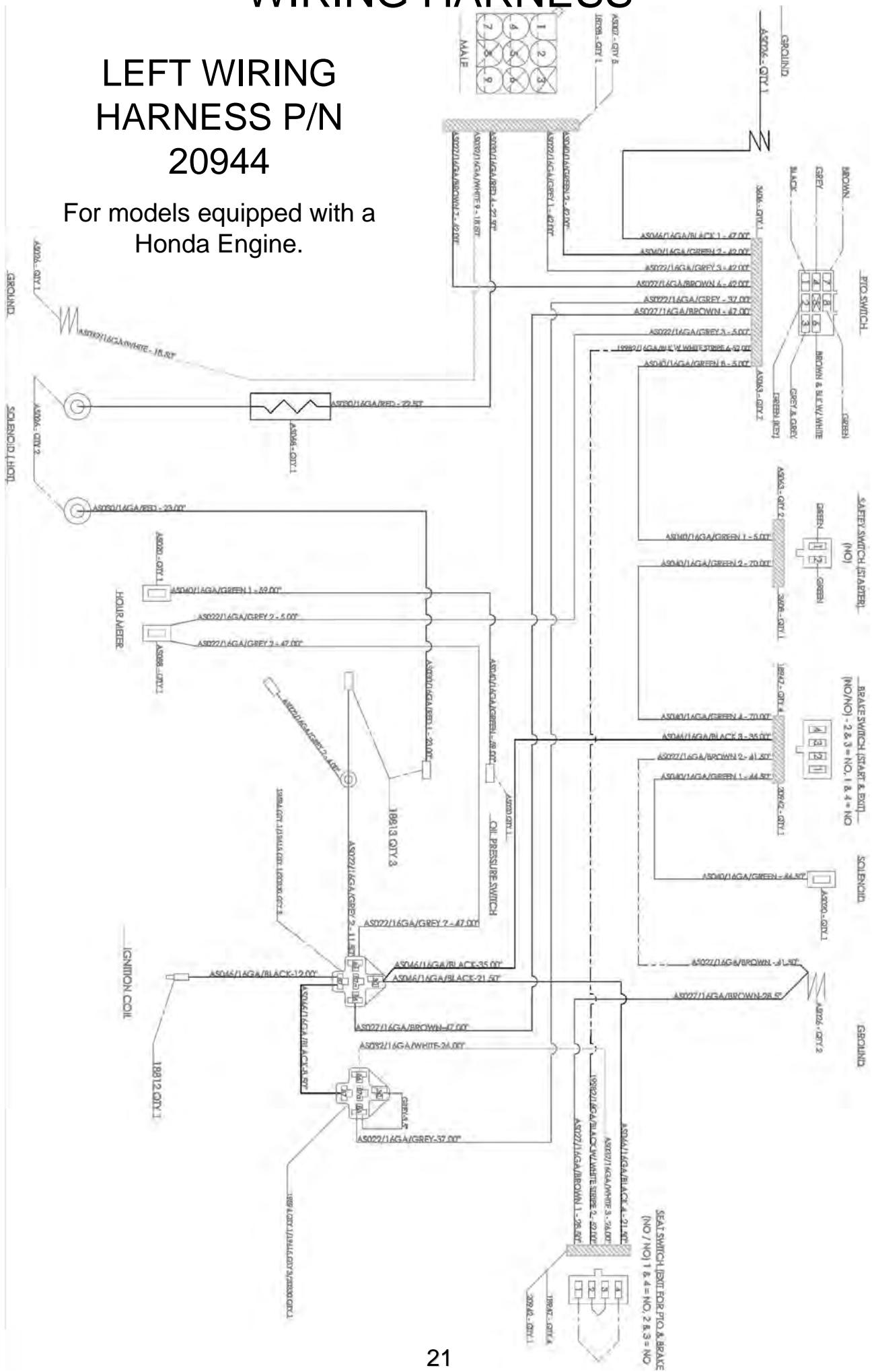

NOTES

NOTES

REPLACEMENT PARTS

Quick Reference

Z21554CPHO, Z21554CPHO-CA

Part #	Description
18811	Belt – Hydro, ½ x 80 ¼
18787	Belt – Engine to Deck ½ x 122
18638	Belt – Deck Idler, ½ x 54
18784	Tire/Wheel – 20 x 10-10, Spoked
18785	Tire/Wheel – 12/600 x 6-4 Ply
20667	Blade – G6 Gator, 18.5"
AS069	Fuse – 10 Amp
20109	Blade – Driver Assembly (Right)
20108	Blade – Driver Assembly (Center & Left)

Z21560CPHO, Z21560CPHO-CA,
Z2460CPKA, Z2460CPKA-CA

Part #	Part Description
18811	Belt – Hydro, ½ x 80 ¼
18746	Belt – Engine to Deck ½ x 126
18637	Belt – Deck Idler, ½ x 55
18784	Tire/Wheel – 20 x 10-10, Spoked
18785	Tire/Wheel – 12/600 x 6-4 Ply
20186	Blade – G6 Gator, 20.5"
AS069	Fuse – 10 Amp
20109	Blade – Driver Assembly (Right)
20108	Blade – Driver Assembly (Center & Left)

Z2466CPKA, Z2466CPKA-CA

Part #	Part Description
18811	Belt – Hydro, ½ x 80 ¼
19069	Belt – Engine to Deck ½ x 130
19070	Belt – Deck Idler, ½ x 62
18784	Tire/Wheel – 20 x 10-10, Spoked
18785	Tire/Wheel – 12/600 x 6-4 Ply
20115	Blade – G6 Gator, 22.5"
AS069	Fuse – 10 Amp
20109	Blade – Driver Assembly (Right)
20108	Blade – Driver Assembly (Center & Left)