

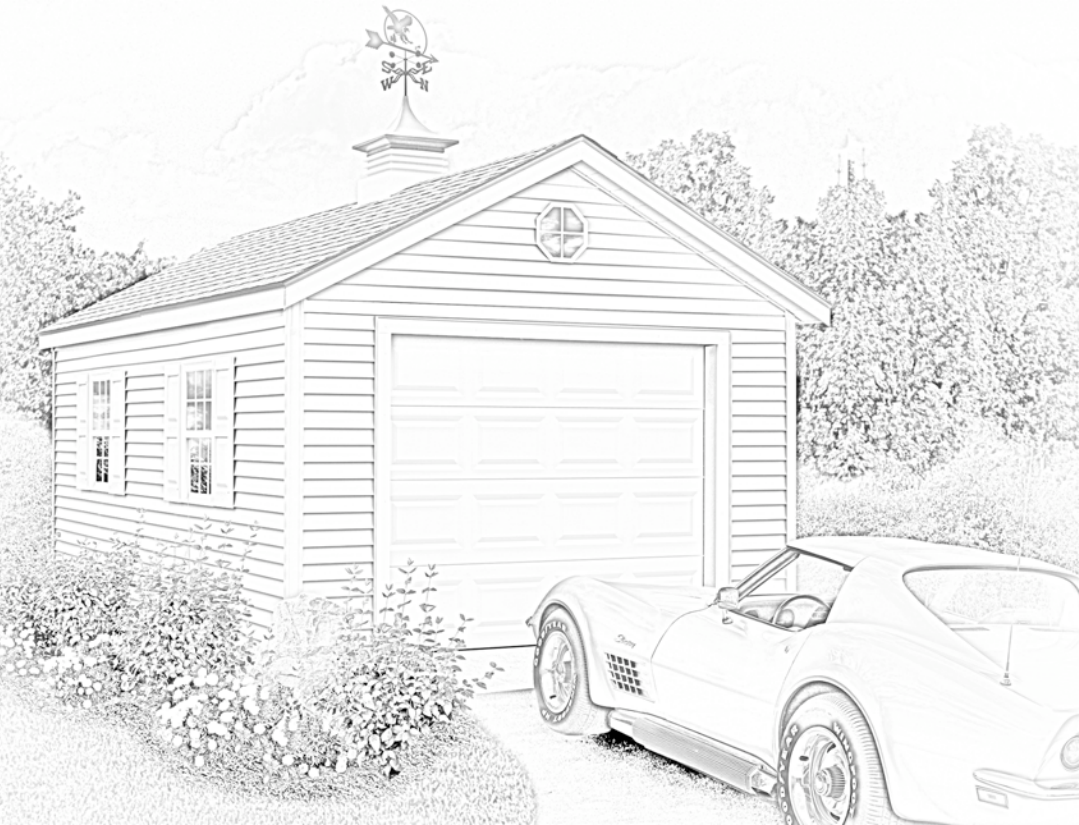

# Best Barns USA Assembly Book

Revised April 28 2015



## the Greenbriar 12' x 20'

**Manufactured by Reynolds Building Systems, Inc.**

205 Arlington Drive

Greenville, PA 16125

724-646-3775

This manual is copyrighted. Under the copyright laws, this manual may not be copied, in whole or in part, without consent from Reynolds Building Systems, Inc. © Copyright 2012

## IMPORTANT INFORMATION ABOUT YOUR SHED KIT

Thank you for purchasing our Greenbriar kit. These instructions will construct a 12'x20' building. **If you received two books, use the one with the latest revision date.**

If you have any questions about assembling the kit, call 800-245-1577. If you are calling after normal business hours, call 724-866-HELP (4357) or email to help@barnkits.com.

Before you begin construction, be sure to study this assembly manual. Also, obtain a building permit and check all pertinent building code regulations.

The material that is included in our kit is listed on the back page. The optional floor package, *if ordered*, will be supplied by a local lumber supplier.

The door opening is for a 8' wide x 7' high garage door. You will need to order your garage door with an 9" low headroom kit.

The foundation size should measure 12'-0" wide by 20'-0". **Do Not** make the foundation larger than the building size. The siding should project beyond the foundation for water to expel properly from the sidewalls.

If you are installing the building on a concrete slab cut the siding flush with the bottom wall plate . Install sill sealer between the bottom plate and the concrete slab. Available from Owens Corning brand comes in 3-1/2" x 50' rolls and sells for under \$7.00 a roll. This material will protect the 2x4 bottom plate from moisture and chemicals in the concrete.

**IMPORTANT:** Unpack the material from the pallet, then unscrew the 2x4s from the pallet. The bit for the screws is packed in the hardware bag. Remove the OSB panel, it will be used for roof sheathing. The 2x4s will be used for wall bracing and interior door jamb material.

When building the trusses, our instructions suggest using the floor as a work area. If your foundation is a concrete slab it will not be possible to use this method. Build the 12' long back wall to use as a platform.

Thank you for your purchase.

Bill & Linda Rinella, owners

## Tool List

- |  |   |
|--|---|
| <input type="checkbox"/> Hammer & Phillips Screwdriver | <input type="checkbox"/> Power Drill/Screwdriver    |
| <input type="checkbox"/> Framing Square & Level        | <input type="checkbox"/> Measuring Tape & Chalkline |
| <input type="checkbox"/> Circular Saw and/or Hand Saw  | <input type="checkbox"/> 2-8' Step Ladders          |

**Always wear safety glasses when cutting or nailing!**

## Optional Wood Floor System

Shown below is a typical wood floor. Depending on your area, the construction may have to be changed to meet local codes. The foundation size should be 12' - 0" x 20' - 0".

1. Cut (2) two treated 2x4-8' boards in half.
2. Butt 4x4-10' treated runners together. Use one of the 4' long 2x4s to secure them together. Note: Use 16d galv. nails to secure all treated framing together.
3. Repeat to join the other 4x4 runners.

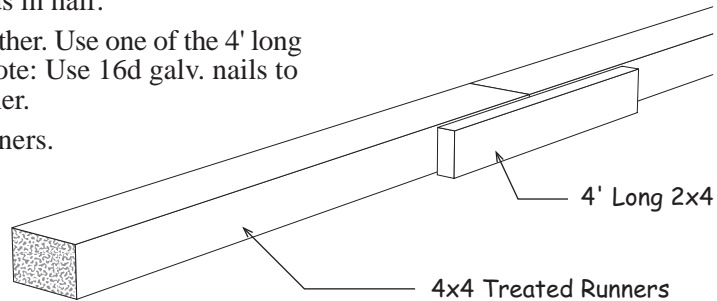

4. Cut (2) two 2x4-12' joist headers to 12' - 0".
5. Layout for 12" on center joist spacing. 'X' marks where floor joist will be placed.

### Detail 1

2x4 - 12' 0"  
Joist Header

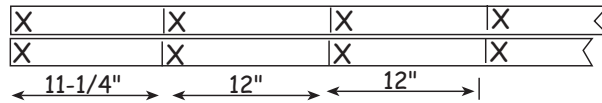

6. Cut all the 2x4-12' boards to 11'-9". These boards will be the floor joist. *Treated lumber may be thicker than 1-1/2". Take this into account when cutting the length of floor joists. Shorten joist measurements if necessary to obtain 12'-0" building width.*
7. Install floor joist boards between the joist headers. Install this section over 4x4s.

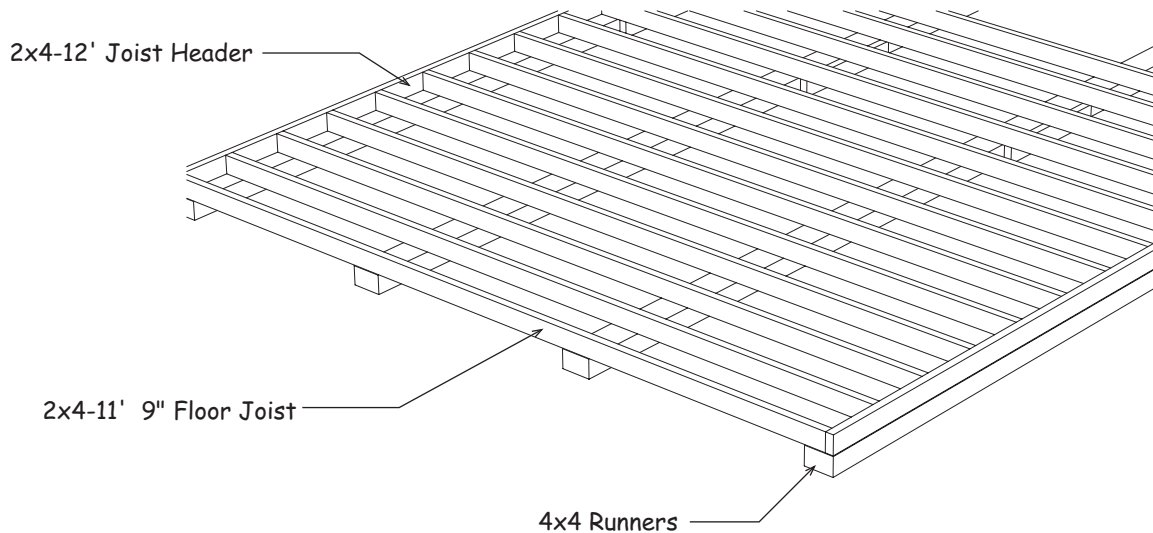

8. Cut (2) two 2x4-8' treated boards to 8' - 0".
9. Layout for 12" on center joist spacing, see **Detail 1**.
10. Assemble another floor section.  
Install over the 4x4s and nail both floor sections together.

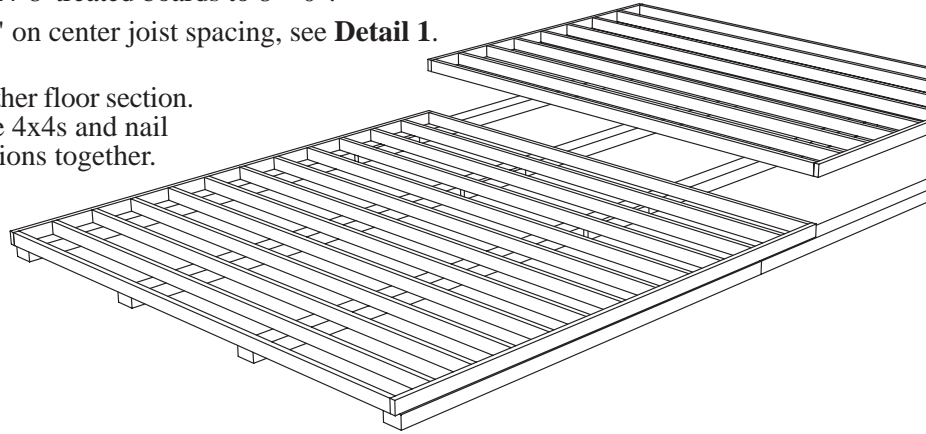

11. Square the floor. See note below. The angle measurement should be 23' - 4". Nail several floor joist to the 4x4 runners to hold the floor frame in place.

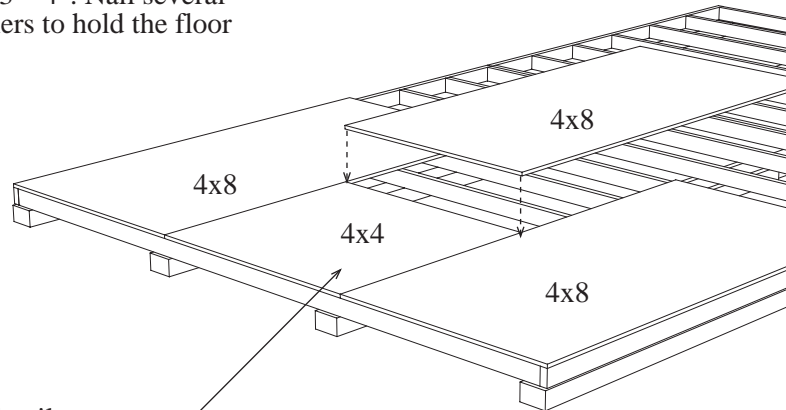
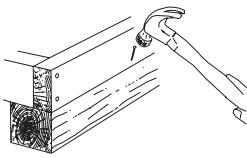

12. Install floor using 8d spiral nails.

Material Description	12' x 20' shed
2x4 Treated	4 pcs. 8'
2x4 Treated	24 pcs. 12'
4x4 Treated Runners	8 pcs. 10'
Flooring 3/4"	8 pcs. 4x8
Screw Floor Nails	5 lb. 8d
Galv. Box Nails	5 lb. 16d

#### ***Notes To Floor***

It is important that the floor be level and square. Square the floor as follows: before nailing the flooring, measure the floor diagonally (corner to corner). Then measure the opposite corners. These measurements will be the same if the floor is square.

## Step 1 Assemble Trusses



**Building Tip:** To aid in the assembly of the trusses, temporarily screw 2x4 blocks to the floor. There are short 2x4s, *that may have an angle on one end*, supplied in kit. This will insure that all the trusses are assembled the same.

1. Screw (2) two 2x4 blocks to the 12' wide end of the floor at the corner, *see below*.
2. Place two truss legs together. Position the notch in the 2x4s (called a bird's mouth) into the 2x4 blocks. **Important:** You must have 12'-0" between the bird's mouth. Affix more 2x4 blocks above the truss legs to hold the truss members in place.
3. Secure the tops together with a wood gusset. Apply wood glue between the 2x4 boards and the gusset. Nail the gusset to the 2x4s with 6d common nails. Use 14 nails per gusset.
4. Install a 2x4-90° collar tie between the 2x4 boards. Hold in place with 2x4 blocks. Install 12"x24" gussets to the ends of the collar tie. Glue and nail using 14 nails per gusset.
5. Turn this truss over and apply wood gussets to the opposite side.
6. Repeat 2 through 5 to assemble (8) eight more trusses.

Do Not remove blocks from floor until completing **Step 2**.

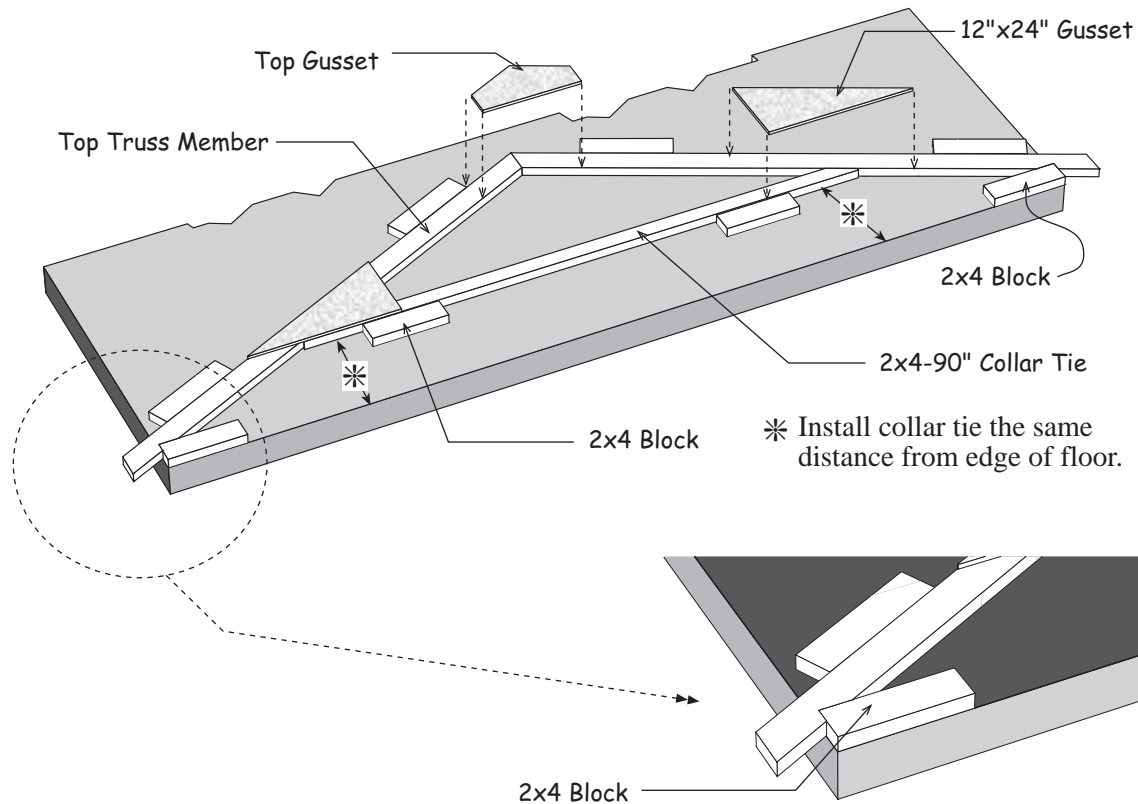

## Step 2 Assemble Roof Gables

1. Butt (2) two 72" long 2x4s together and secure by nailing a 3-1/2" x 31-3/4" long plywood gusset across the top where they butt together. Use glue and 6d common nails.

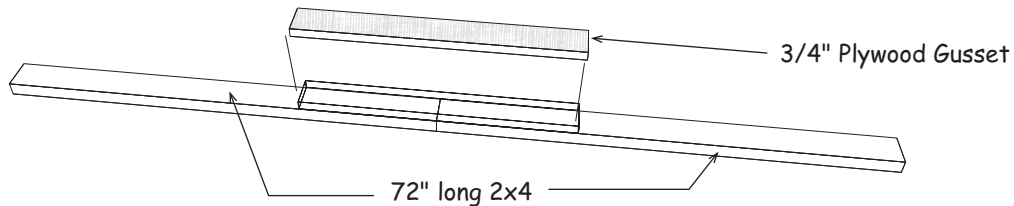

2. Place (2) two truss members in the jig. Secure the top together with a barbed metal plate.
3. Remove the 2x4 blocks at the corners of the floor and insert the gable plate assembled above into the bird's mouth. Make sure the 2x4 gable plate is straight. If necessary, tack 2x4 blocks to hold plate straight.

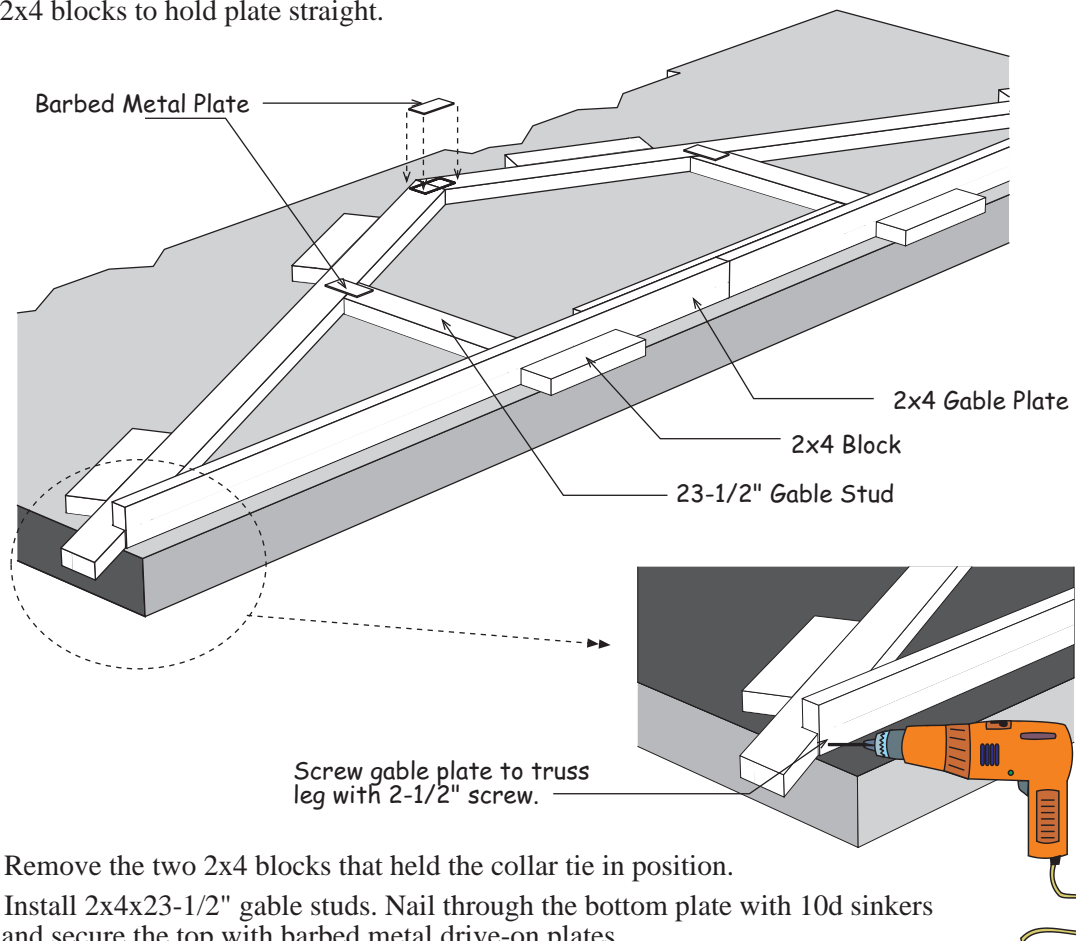

4. Remove the two 2x4 blocks that held the collar tie in position.
5. Install 2x4x23-1/2" gable studs. Nail through the bottom plate with 10d sinkers and secure the top with barbed metal drive-on plates.
7. Repeat to assemble another gable. Remove 2x4 blocks.

## Step 3A Install Siding on Gables

1. Select one of the gable frames, Turn the gable over letting the bottom plate overhang the floor so the gable lays flat.

2. Install gable siding using 6d galv. nails across the top of the gable frame. Use 8d galv. nails along the bottom edge.

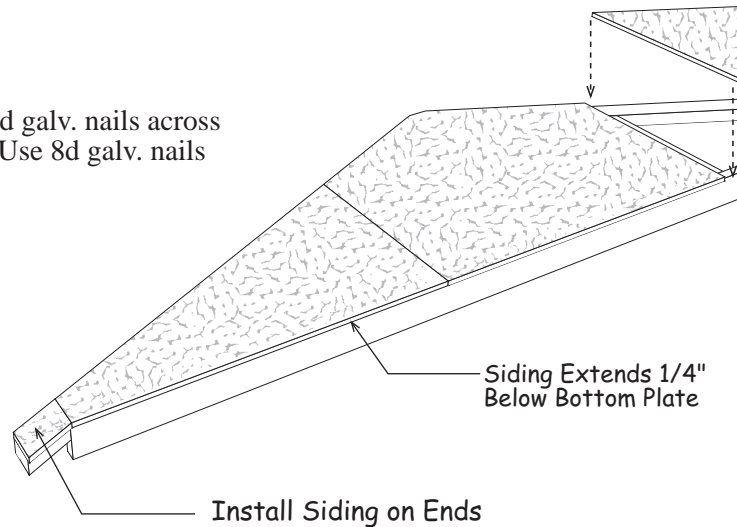

3. Install siding on the other gable frame.

## Step 3B Build 2x4 Assembly

1. Locate (2) two 49-1/2" boards that have shorter 2x4s attached. Butt these boards together.

2. Apply glue over the exposed area of the longer boards. Using 6d common, nail a 3-1/2" x 44" OSB filler over the bottom boards. Align the boards against the floor or other object to make sure the boards are straight before securing the OSB filler.

3. Install a 55" long 2x4 over the OSB filler. For added strength apply glue between the 2x4 board and the OSB filler. Secure with (8) eight 2-1/2" long deck screws at each end and the center.

4. Mark this side (B) so when installed this side will face the back of the building. Another layer of 2x4s will be installed after the 1x6 door jamb is installed

5. Install (8) eight more screws on the opposite side in the center as shown.

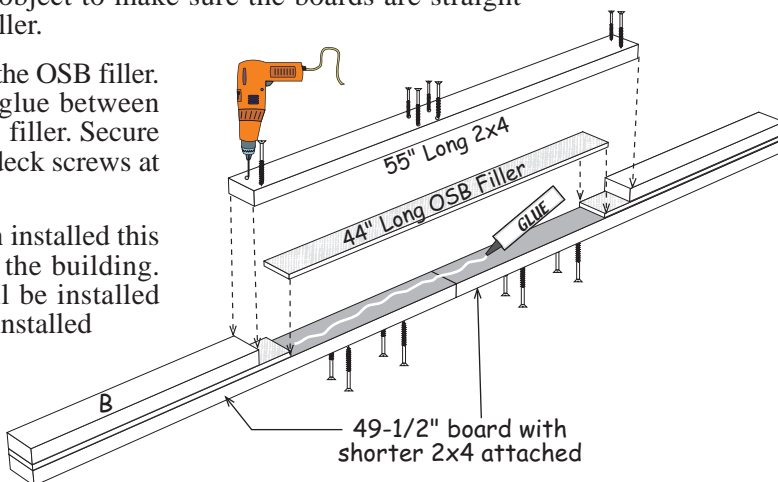

## Step 4 Assemble 12' Back Wall

1. Position 2x4-68-1/2" boards together and indicate with 'X' marks, where the wall studs will be located. Mark the ends that will butt together with the letters 'A' and 'B'.

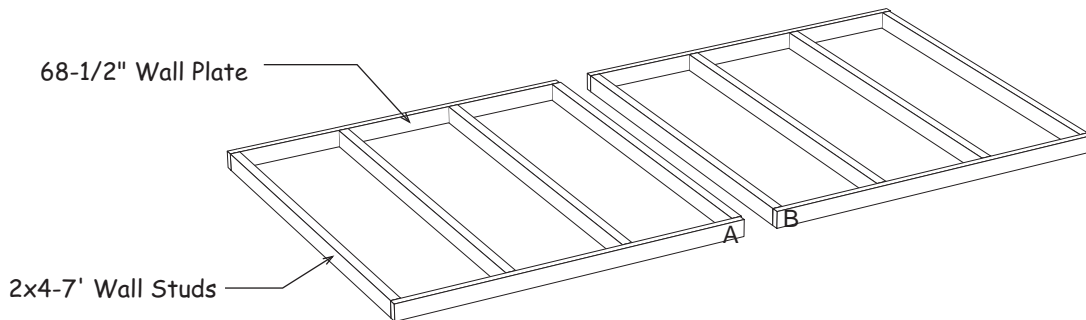
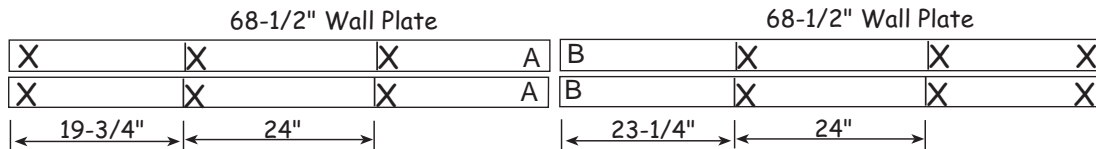

2. Install 7' wall studs between the top and bottom plates. Assemble wall frames with 10d sinkers, two (2) nails at each stud end. Nail both wall frames together.
3. Square wall frame. *Measure diagonally (corner to corner). The measurements will be the same when the wall is square.*
4. Install the first siding panel with the edge extending 3-1/2" past the wall frame. The bottom will extend 3/4" below the bottom plate. Use 8d galv. nails spaced 12" apart.
5. Install the other siding panels. The last panel will extend 3-1/2" beyond the last wall stud.

 ***The siding will be 1/2" below the top of the wall frame on all walls.***

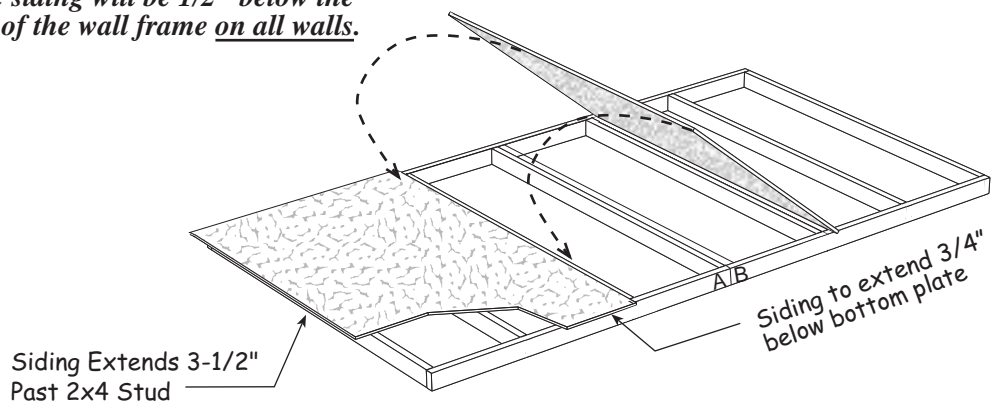



## Step 5 Assemble 10' Long Sidewalls

1. Position (2) two 2x4-48" boards and (2) two 2x4-72" boards together and indicate with 'X' marks, where the wall studs will be located.

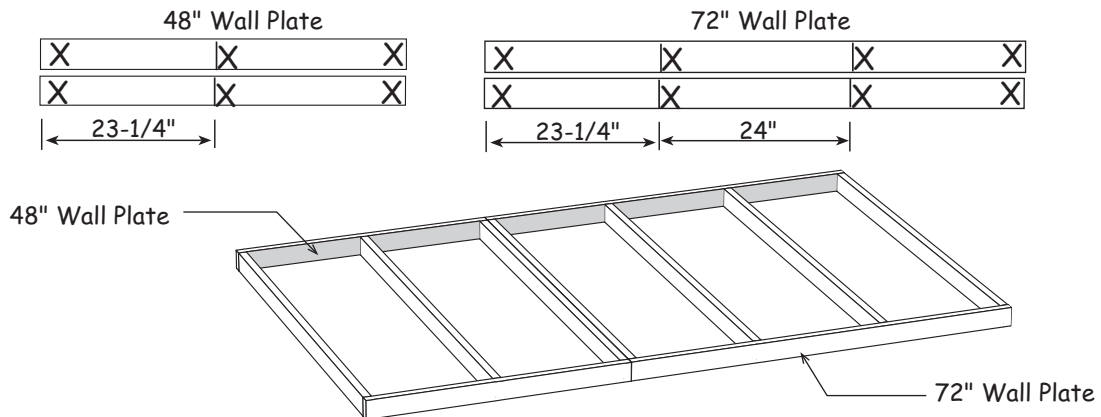

 If you are installing the optional walk-in door see the instructions at the back of the book.

2. Install 7' wall studs between the top and bottom plates. Nail both wall frames together.
3. Repeat to assemble (3) three more 10' long sidewall frames.

## Step 6 Assemble Sidewalls for 20' Building Length

1. Square wall frame. Select (1) one of the 2' wide panels and install panel with the edge flush with the end of the wall and extending 3/4" below the bottom plate.
2. Install (2) two more full width siding panels.

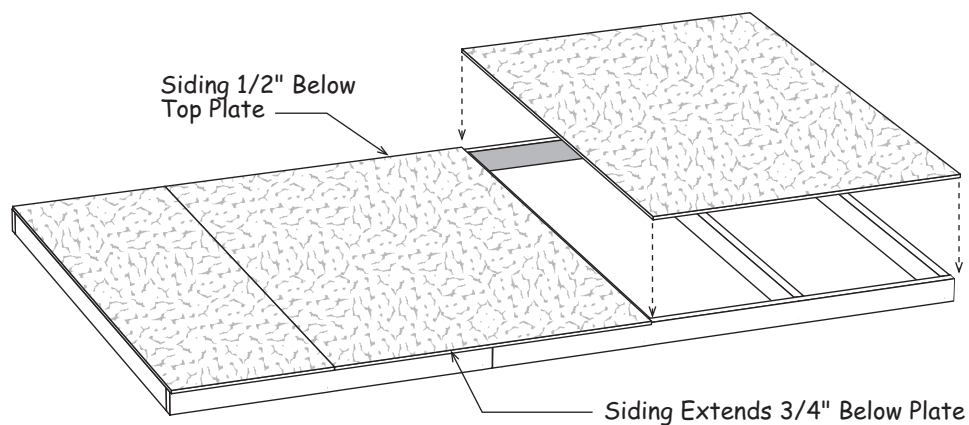

3. Repeat to apply siding to (3) three more sidewall frames.

## Step 7 Assemble Door Walls

1. Locate a 7' wall stud with a 83-1/2" long 2x4 attached.
2. Assemble a wall frame using a 7' wall stud, the double stud and (2) two 19" long 2x4 wall plates. Use 10d sinkers.

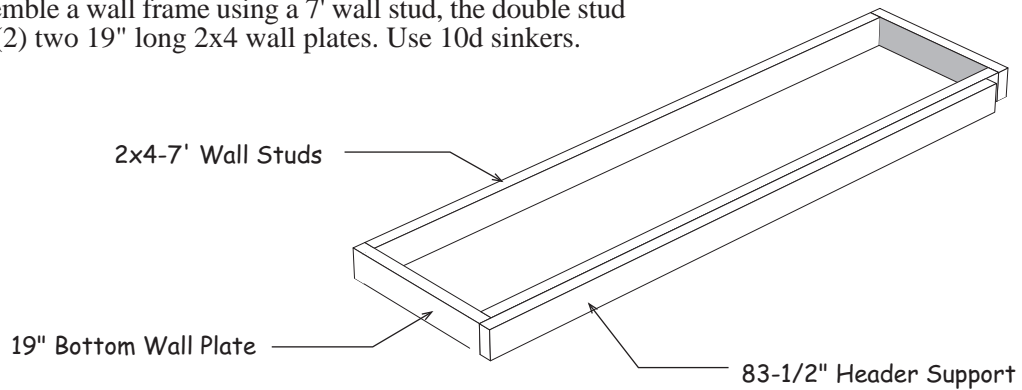

3. Repeat to assemble another wall frame.

4. Cut a panel in half and install a 24" wide siding panel flush with the 2x4 header support and extending 3/4" below the bottom plate.

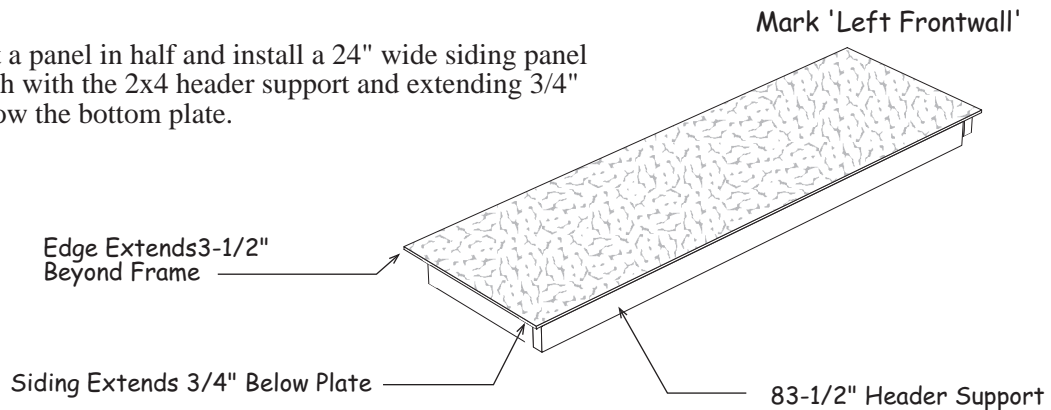

Mark 'Right Frontwall'

5. Install the remaining siding panel flush with the edge of the 2x4 header support.

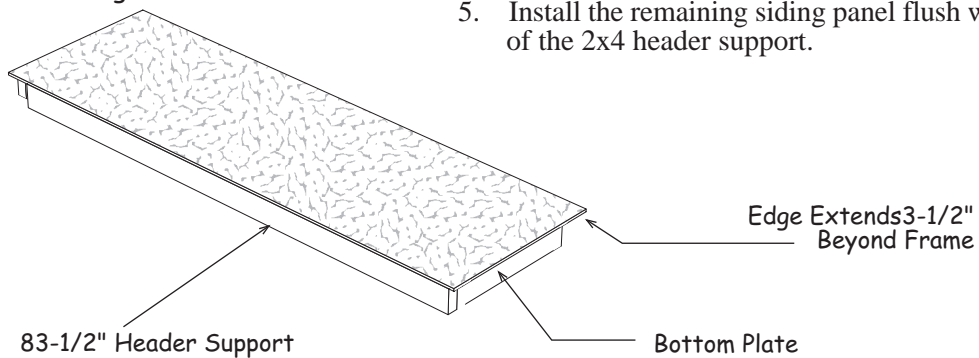

## Step 8 Set Walls

1. Set wall panels. Secure at corners with 10d sinkers (4 nails per corner). Secure to floor with 10 sinkers. Disassemble shipping pallet and use the 2x4s to brace the front wall and the sidewalls.
2. Install the pre-built 2x4 assembly, from **Step 3B**, between the front wall panels. Install assembly on the front wall panels with the side marked with the letter 'B' facing the back of the building.
3. Install (2) two 3-1/2" x 48" siding panels over the built-up assembly.

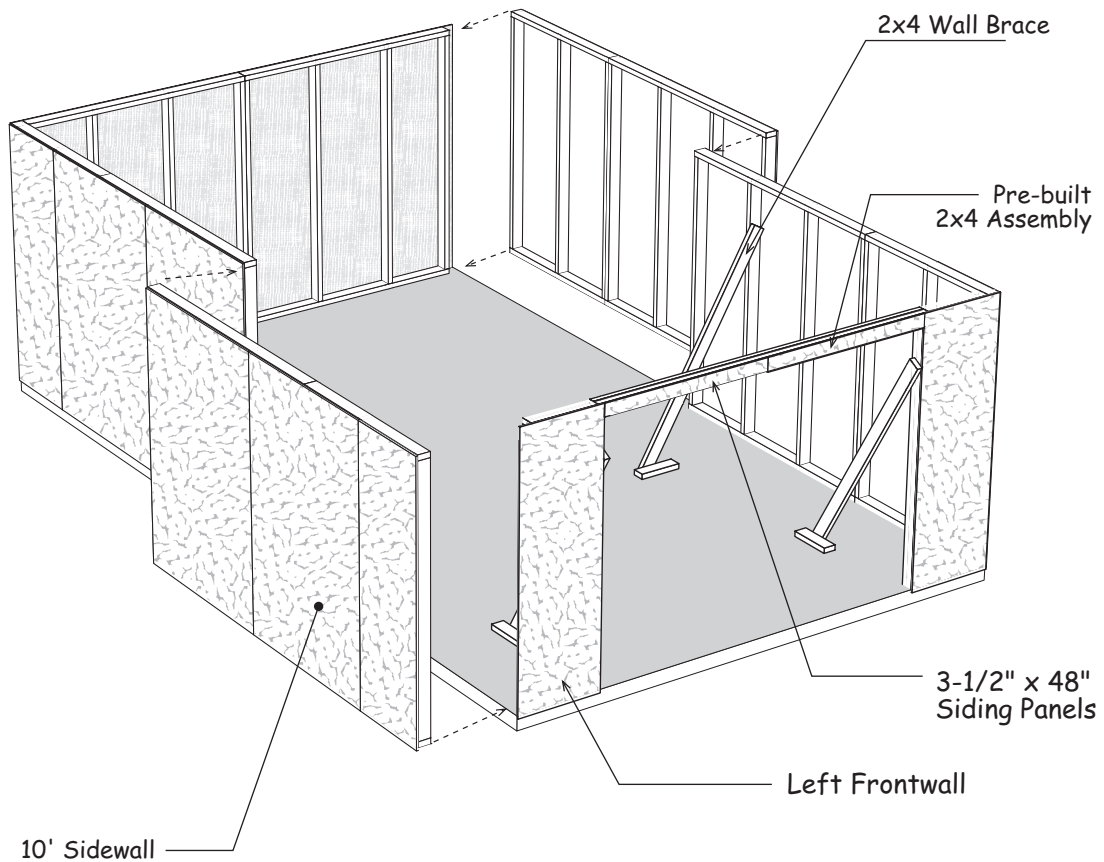

## Step 9 Install 2x4 gable Overhang

1. Install (2) two 86-1/4" long 2x4s on the gable, flush with the top of the gable siding. Secure with 10d sinkers.

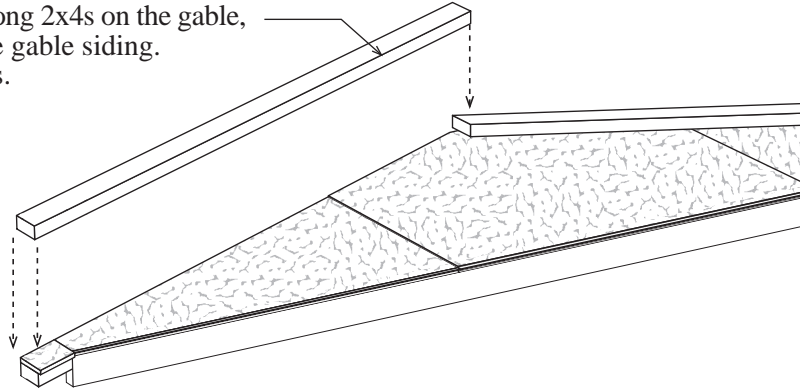

2. Repeat to install 2x4s on the another gable frame.

## Step 10 Install Front Wall Door Jamb

1. Install 48" long x 5-3/8" wide primed siding material on the top of the door opening.
2. Install 83" long x 5-3/8" wide primed siding material on the sides of the door opening.

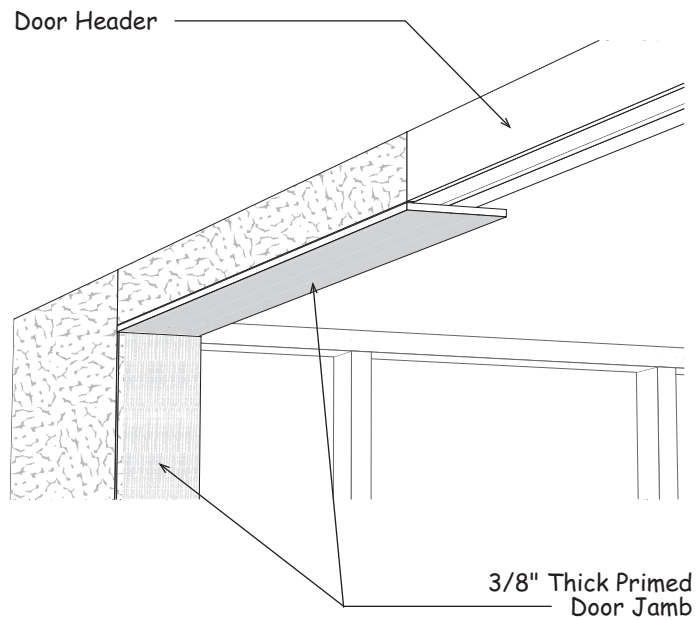

## Step 11 Install Gables

1. Install a gable on the rear wall. Secure gable to wall by nailing through the gable plate with 10d sinkers.

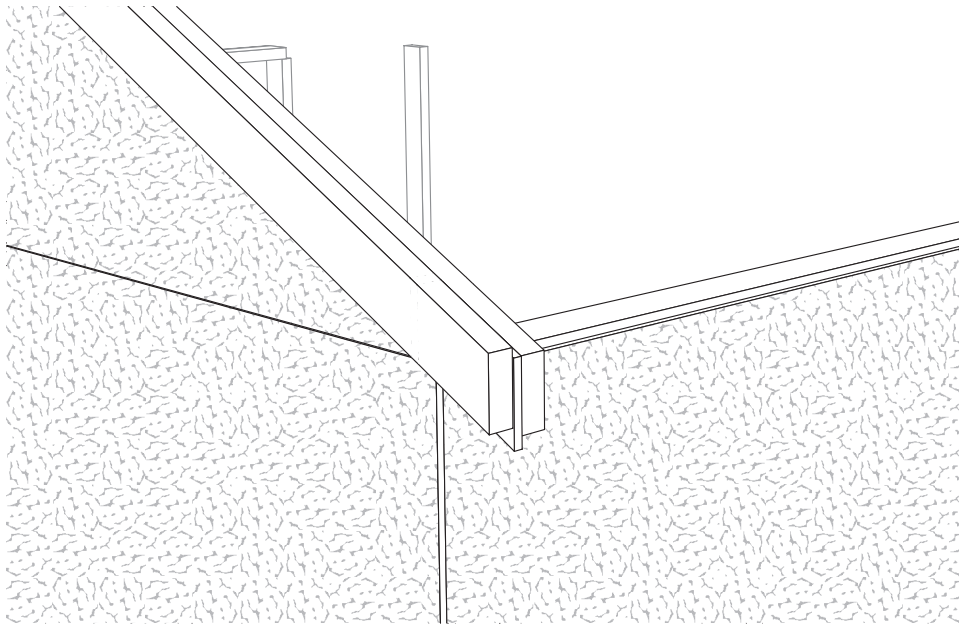

2. Repeat to install a gable on the front wall.

## Step 12 Install 2x4 Tie Plates

1. Install a 2x4-6' board over the sidewall, against the rear gable plate. Use 10d sinkers.

2x4-6' Tie Plates

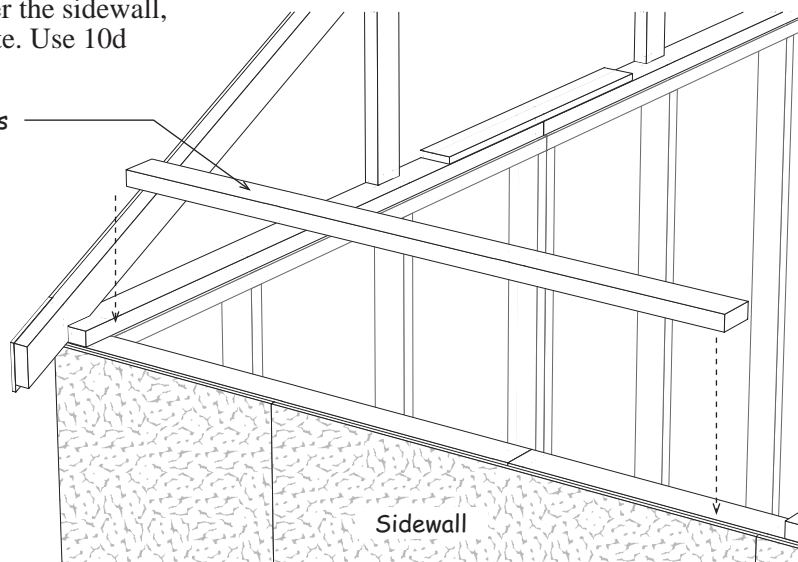

2. Install (2) two more 2x4-6' boards next to the first one.
3. Install a 48" long 2x4 at the front of the building.
4. Install 2x4 tie plates on the opposite sidewall.

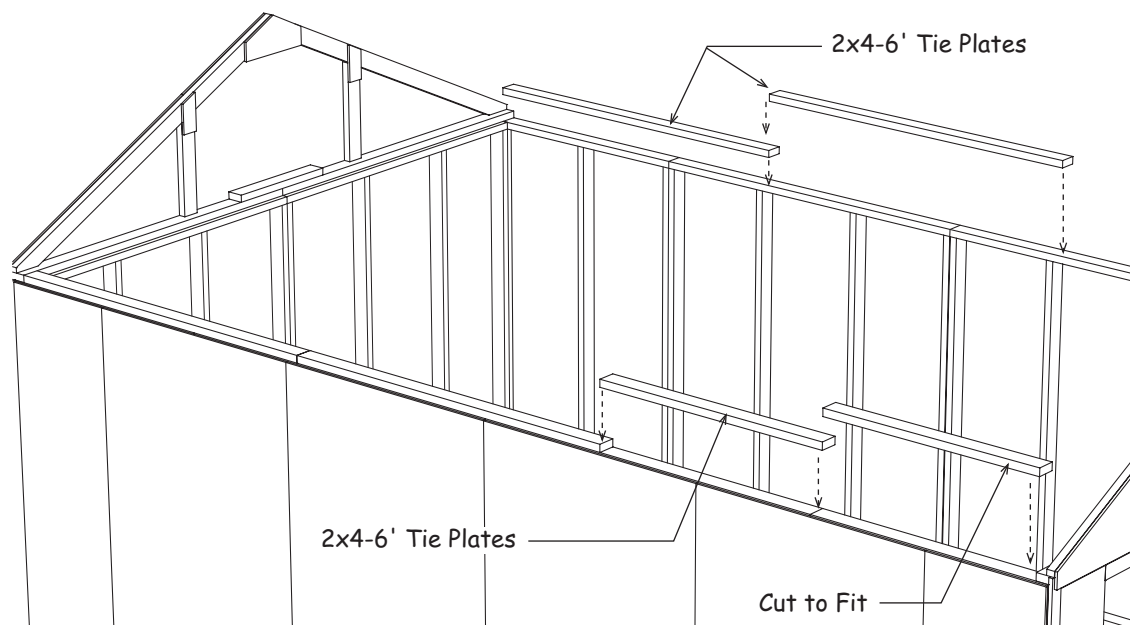

## Step 13 Layout Roof Trusses

1. Layout the truss spacing from the rear of the building. Measure from the inside of the rear gable when marking the location of the first truss. **Important:** When marking the opposite wall, place the 'X' mark on the same side of the line so your trusses are parallel when they are installed.
2. Using 1-1/2" hanger nails, install metal hangers to the 2x4 tie plate. The opening should line up with the 'X' mark, the bottom of the opening, flush with the 2x4 tie plate. See **Detail 'D'**.

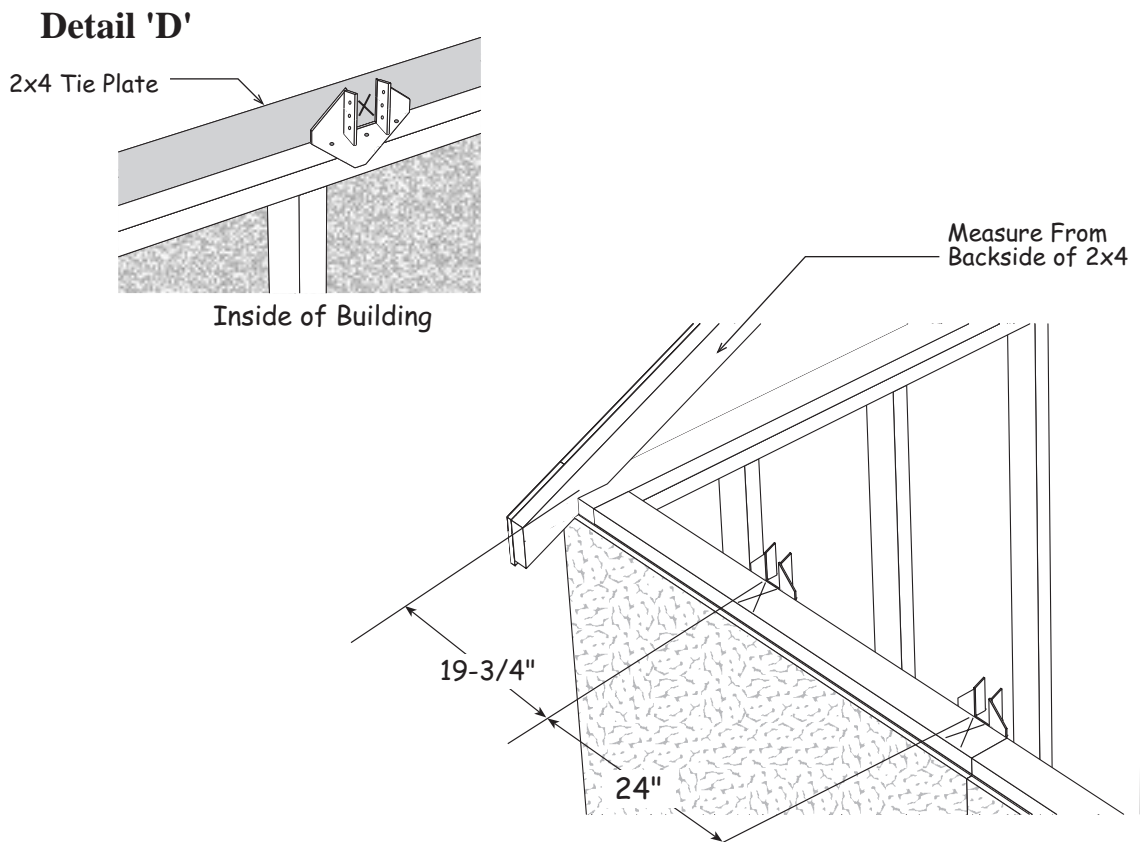

## Step 14 Set Roof Trusses

Set roof trusses. Secure trusses to metal hangers with 1-1/2" hanger nails.

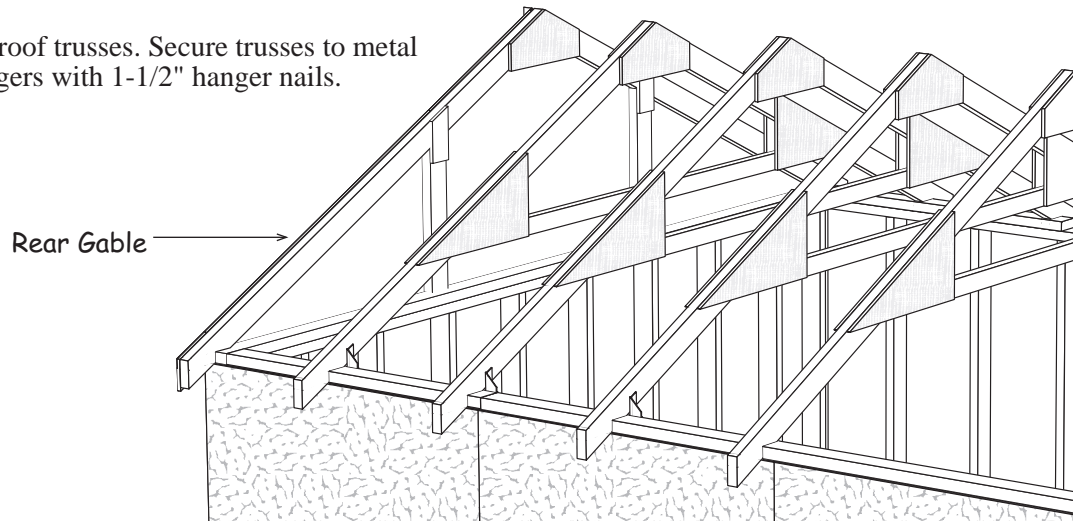

## Step 15 Install Eave Soffit

Install 5" wide siding panels as soffit under the truss overhang. Use 8d galv. nails.

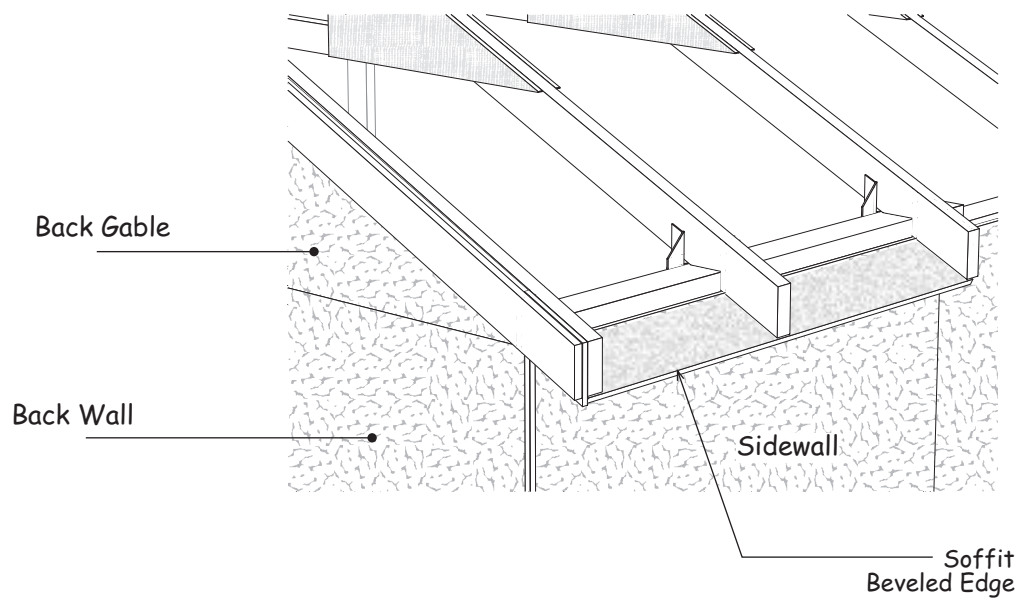



## Step 16 Install 1x6 Fascia

When installing 1x6 fascia, *see below*, it will be necessary to install 22-1/2" long 2x4 blocks between trusses where the fascia boards meet.

The 2x4 blocks have a beveled edge on the top to allow the roof sheathing to rest on. Install block through the end of the trusses with 10d sinkers.

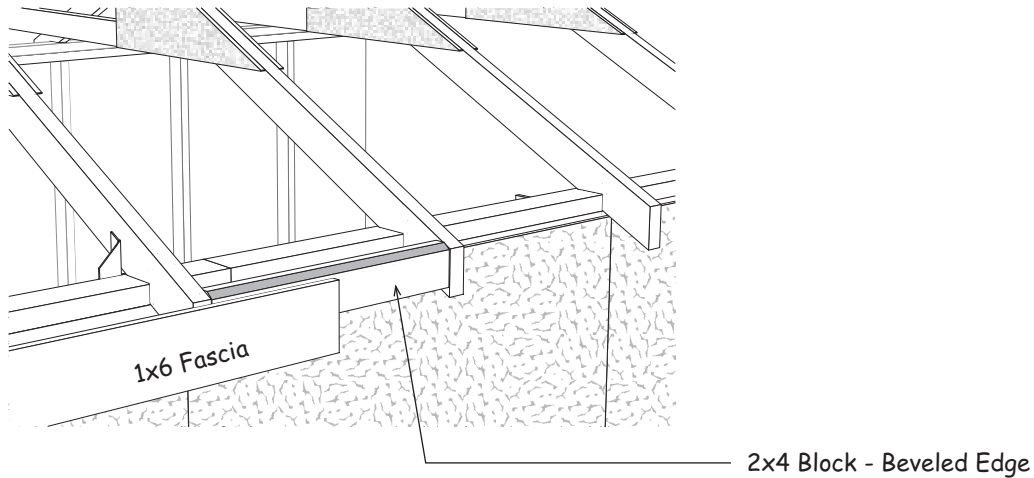

Starting at the rear of the building, install 4'x6' OSB roof panels and 1x6-7' white pine fascia boards on each side flush with the face of the siding on the back gable. Install the fascia so the bottom edge of the roof sheathing will rest on the 1x6. Use 8d galv. nails to install fascia.

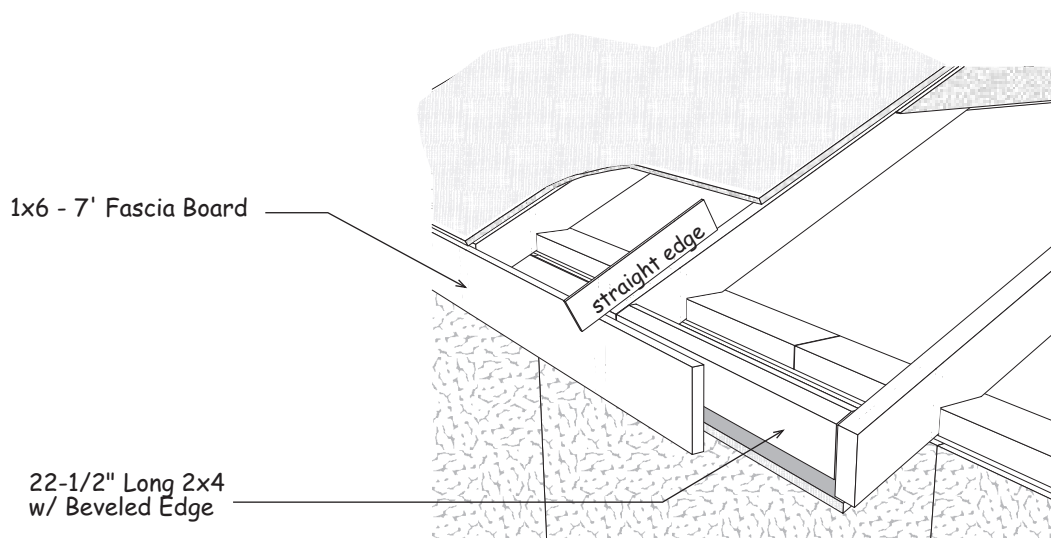

## Step 17 Install Roof Sheathing

1. Cut (2) two 37-1/2" x 83-1/2" OSB panels to a length of 81-1/2". One of the panel was fastened to the shipping pallet.
2. Cut (2) two 4 8" wide x (81-1/2" or 90") OSB panels to a length of 57-1/2". One of the OSB panels was fastened to the shipping pallet.
3. Install roof sheathing per layout below. Make sure the trusses are plumb and the roof sheathing meets the center of the truss. Use 7d sinkers spaced 12" apart. The top row of roof sheathing will be about 1" below the ridge to allow for ventilation.

**Important:** Make sure the front gable is plumb and the roof sheathing extends 8-1/2" past the siding along the face of the gable.

4. Install a 1x6 - 7' fascia board. Install a 22-1/2" long 2x4 soffit block, *with beveled edge*, between the truss.

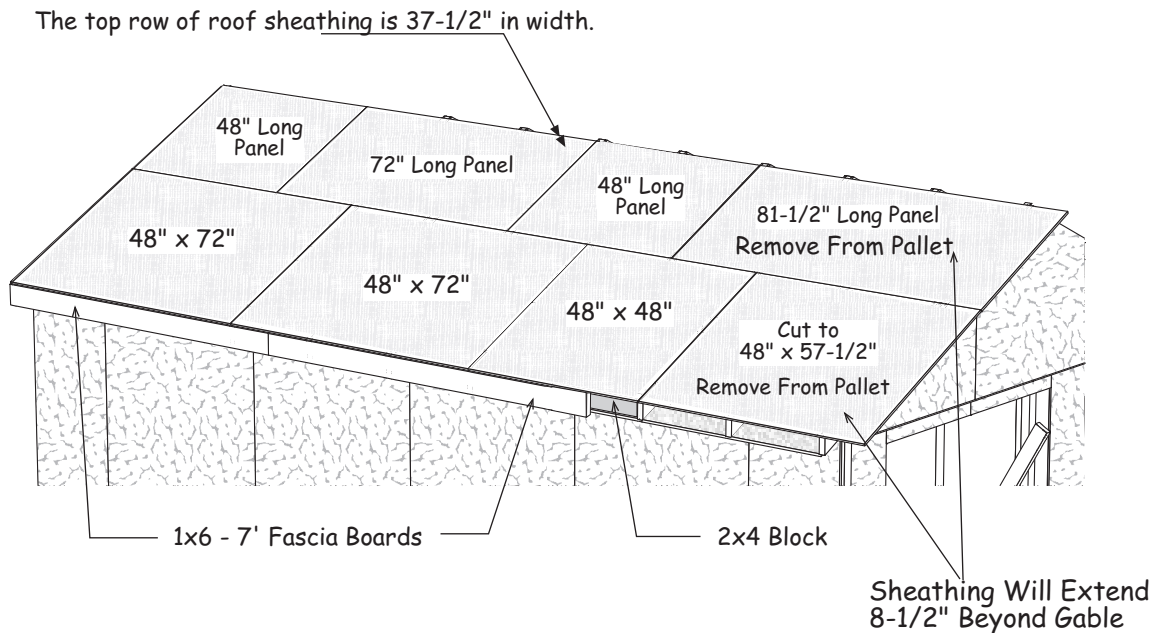

## Step 18 Install Front Soffit

1. Install 86" long 2x4s under the front edge of the roof sheathing. Hold the 2x4s against the roof sheathing and screw through the sheathing into the 2x4 boards. Use 1-5/8" long screws.
2. Install 8-1/2" wide siding under the gable overhang as the soffit. Use 6d galv. nails.

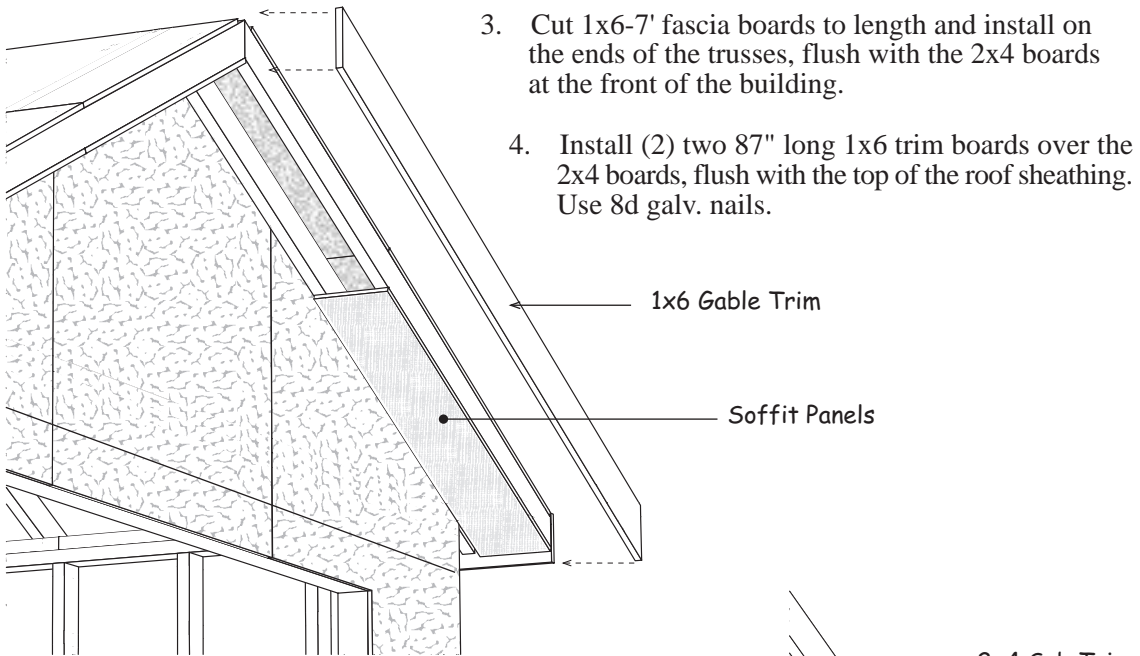

5. Install 1x6 trim on the rear gable, flush with the top of the roof sheathing. Use 8d galv. nails.

The 1x6 gable trim will extend below the 2x4 sub-trim creating a slot for the vinyl siding.

Install vinyl outside corners under the 1x6 gable trim.

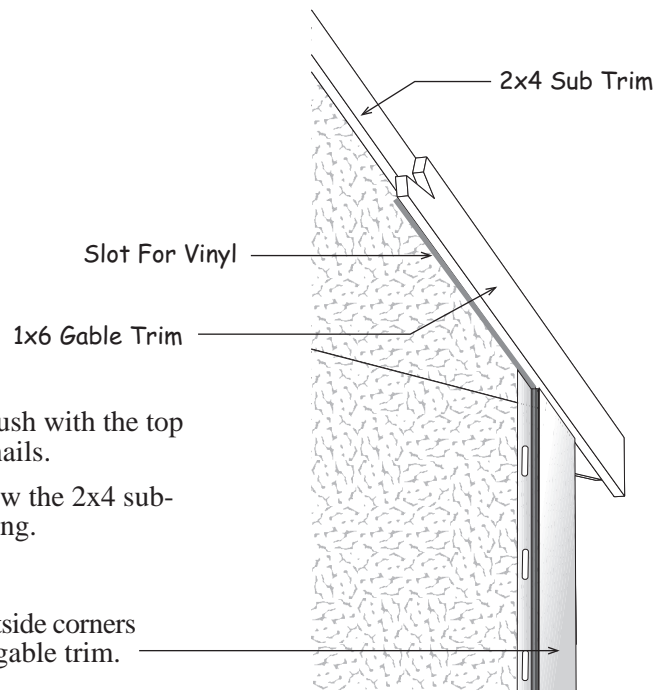

## Step 19 Install Door Trim

1. Install 1x4-84" trim boards along each side of the door opening.
2. Install (2) two 51-1/4" long trim boards across the top of the door opening.

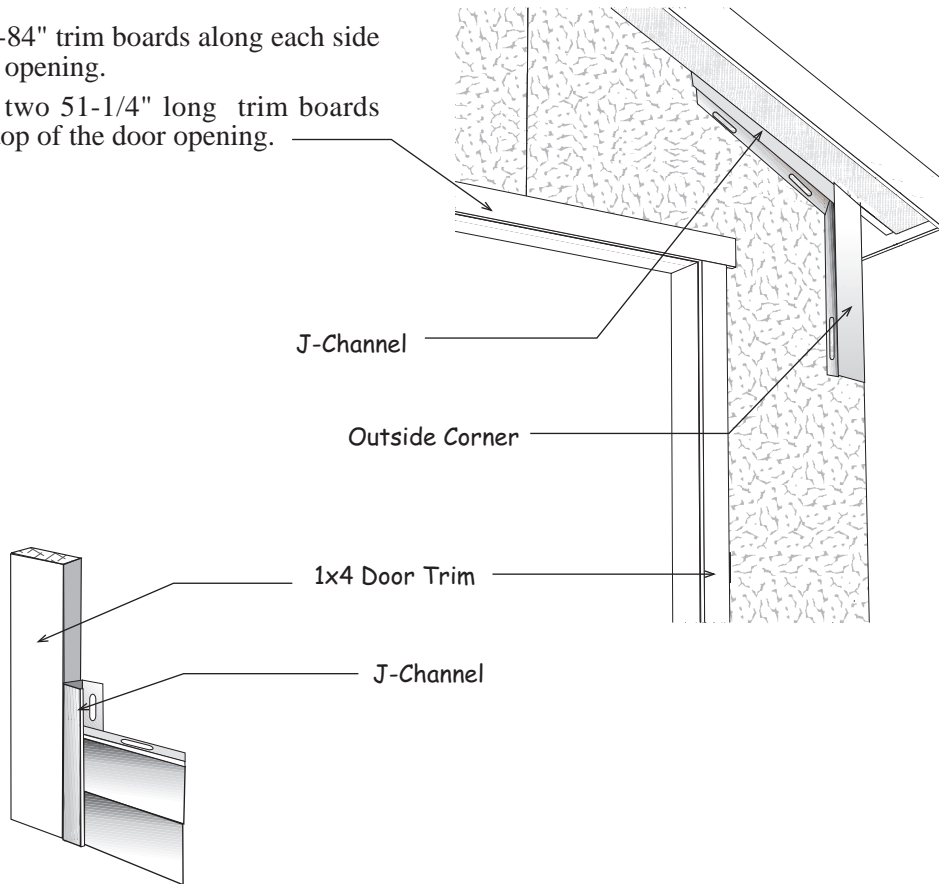

### *Vinyl Siding Overview*

Install the siding according to the manufacturer's instructions.

Starter Strip is installed along the bottom of the building.

Center the nail in the nailing slots. **DO NOT** nail the siding tight. The panels should float on the nails to provide for expansion and contraction. Nail into wall studs wherever possible. If it is necessary to nail between the studs, cutoff the tips of nails that protrude through the siding.

When installed, the siding panels should have 1/4" free space at each end of the siding panel. This will allow the panel to expand with changes in temperature.

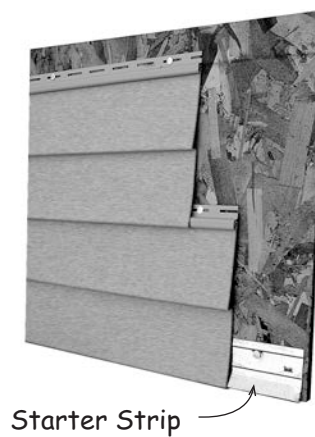

## Step 20 Install 2x4 Around Door Jamb

1. Install a 2x4 - 7' on the inside of the door opening to support the door track.  
Use 2x4 wall bracing material
2. Install 51-1/2" long 2x4s across the top of the door jamb.

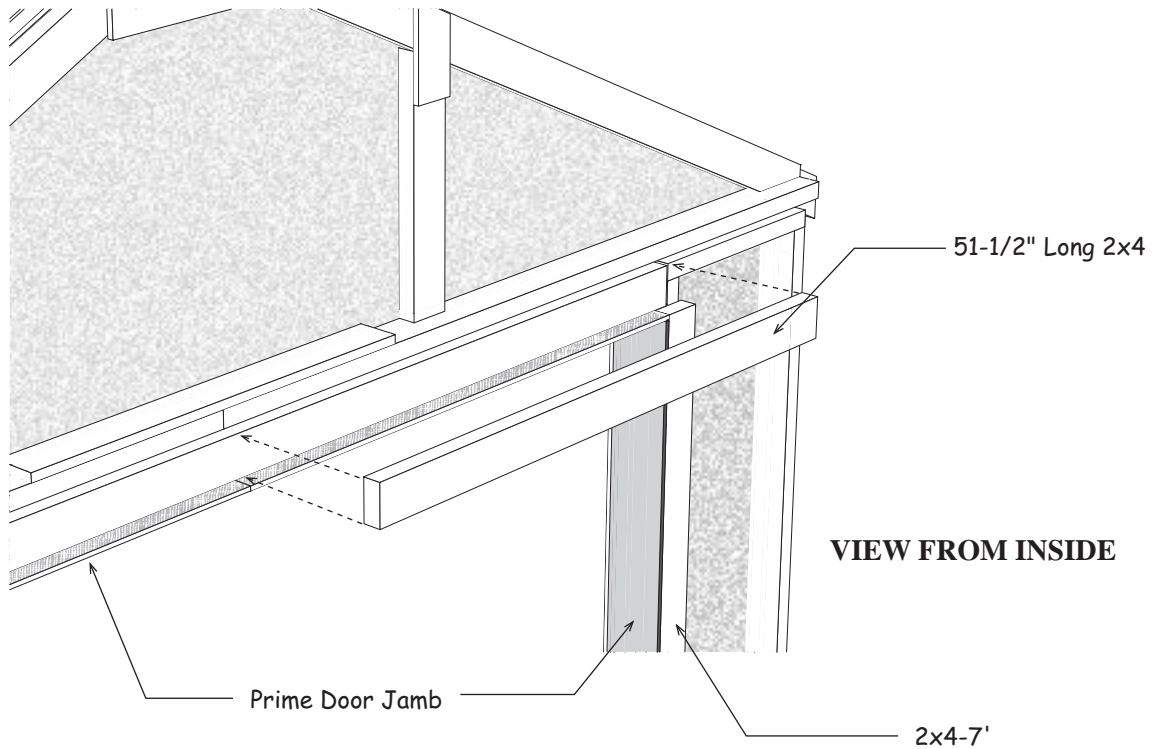

## Install Optional Door Sill

If you ordered the optional floor, install the galvanized door sill. Secure sill with pan head screws.

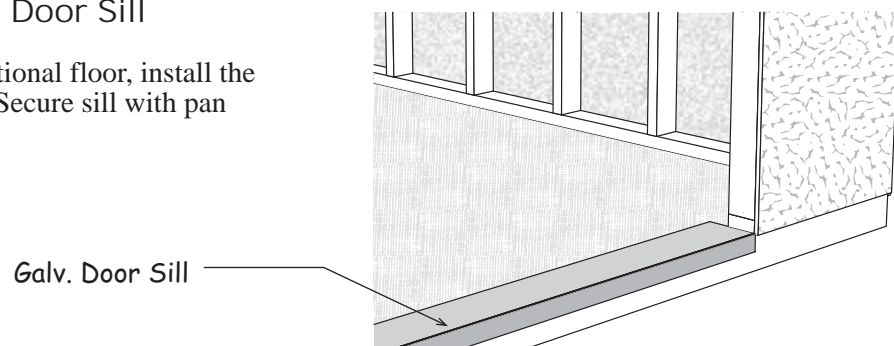

## Step 21 Install Roofing — Not Supplied in Kit

1. Install metal roof edging perimeter of the roof area. If you are not installing shingles at this time, you can purchase felt paper to protect the roof sheathing. Install the felt paper before you install the metal roof edge.

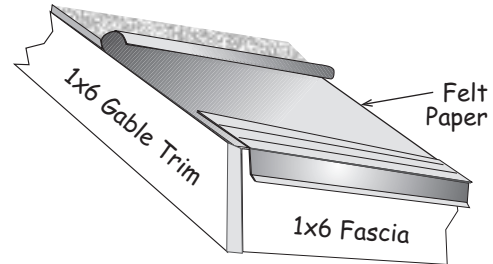

2. Install shingles according to the instructions on the wrapper. If you need more detailed instructions on installing shingles, there are good publications at book stores or newsstands.

**Building Tip:** Install a ridge vent in lieu of shingle caps. Ridge vent provides ideal ventilation, preventing heat or moisture from damaging your building or its contents.

*Optional ridge vent provides ideal ventilation.*

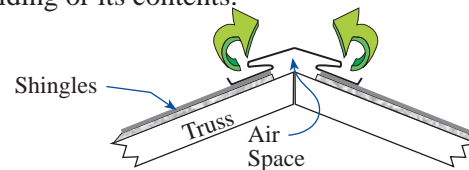

## Optional Door Opening

1. Cut (2) two 80-1/2" long header supports from 2x4-7' boards.
2. Cut (2) two 37-1/2" boards from a 2x4-7'.
3. Cut a 3-1/2" x 37-1/2" filler from a 48" long OSB board included in the kit.
4. Assemble the door header.
5. Install door header over header supports.

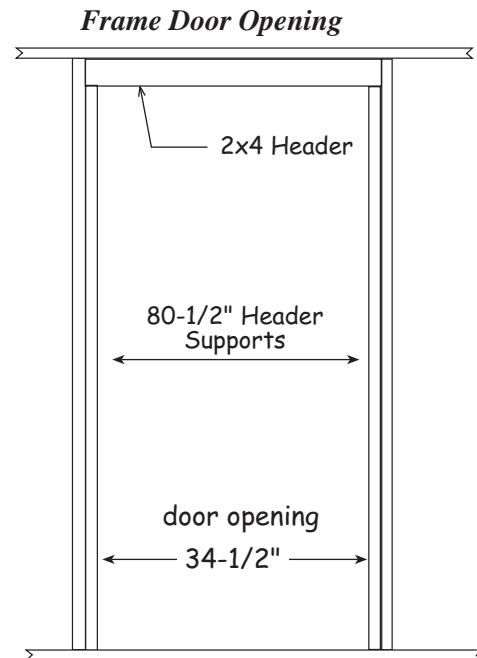
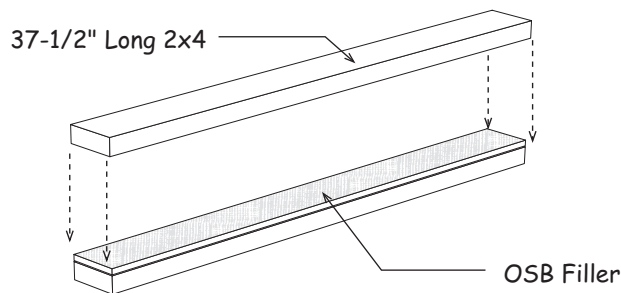

***Material Packaged In Lumber Kit***

7	Collar Ties	2x4	90"	3	1 lb. box	10d	Sinkers
22	Truss Rafters	2x4	86-1/4"	3	1 lb. box	8d	Galv.
35	Wall Studs	2x4	84"	2	1 lb. box	7d	Sinkers
2	Double Studs	2x4	84"	1	1 lb. box	6d	Galv.
18	Wall Plates	2x4	72"	3	1 lb. box	6d	Common
4	Wall Plates	2x4	68-1/2"	1	1 lb. box	1-1/2"	Hanger Nails
2	Door Jamb	2x4	51-1/2"	6	ea.	1x4	Metal Plates
1	Door Assembly	2x4	55"	14	ea.	2x4	Metal Truss Hangers
4	Wall Plates	2x4	48"	1	bag		Wood Screws
4	Wall Plates	2x4	19"	2	ea.		Bottle Glue
4	Gable Studs	2x4	23-1/2"	4	pcs.	1x6 Gable Trim	87"
2	Pre-built Door Assembly		49-1/2"	6	pcs.	1x6 Fascia Trim	84"
2	SidingOver Door	3/8"	3-1/2" x 48"	2	pcs.	1x4 Door Trim-sides	84"
8	Primed Soffit Boards	3/8"	5" x 48"	2	pcs.	1x4 Door Trim-top	51-1/4"
2	Primed Soffit Boards	3/8"	5" x 24"	1	pc.	7/16" Filler Board	3-1/2" x 44"
4	Primed Soffit Boards	3/8"	8-1/2" x 48"	2	pcs.	7/16" Filler Board	3-1/2" x 48"
2	Primed Door Jamb	3/8"	5-3/8" x 48"	14	pcs.	7/16" Truss Gussets	8" x 20"
2	Primed Door Jamb	3/8"	5-3/8" x 83"	28	pcs.	7/16" Truss Gussets	12" x 24"
2	Plywood Gusset	3/4" x 3-1/2"	32"	2	pcs.	7/16" OSB	37-1/2" x 83-1/2"

Continued On Back Page

***Material Packaged In Siding & Roof Sheathing Kit***

2 pcs.	2x4 Collar Ties	90"	11	Siding Panels	48" x 87-1/4"
6 pcs.	2x4 Truss Rafters	86-1/4"	6	Siding Panels	24" x 87-1/4"
6 pcs.	2x4 Wall Studs	84"	2	Siding Panels-Gables	48" x 40"
4 pcs.	2x4 Wall Plates	48"	4	Siding Panels-Gables	48" x 28"
4 pcs.	2x4 Fascia Blocks	22-1/2"	2	Roof Sheathing	37-1/2" x 72"
4 pcs.	716"Wood Gussets	8" x 20"	4	Roof Sheathing	37-1/2" x 48"
8 pcs.	716"Wood Gussets	12" x 24"	4	Roof Sheathing	48" x 72"
1 lb.	10d Sinkers Nails		2	Roof Sheathing	48" x 90"
1 lb.	8d Galv. Nails				to be cut to 57-1/2"
1 lb.	7d Sinkers		2	Roof Sheathing	48" x 48"
1 lb.	6d Common		2	Sidewall Soffit	5" x 48"
1/2 lb.	1-1/2" Hanger Nails		4	2x4 Metal Truss Hangers	

**Roof Covering - not supplied in kit**

12 bdl.	Roof Shingles	
9 pcs.	Roof 'drip' Edge	10'