



4000 GALLONS KOI POND PRESSURE BIO AQUARIUM FILTER

ITEM: 71015



OWNER'S MANUAL AND SAFETY INSTRUCTIONS

SAVE THIS MANUAL: KEEP THIS MANUAL FOR SAFETY WARNINGS, PRECAUTIONS, ASSEMBLY, OPERATING, INSPECTION, MAINTENANCE AND CLEANING PROCEDURES. WRITE THE PRODUCT'S SERIAL NUMBER ON THE BACK OF THE MANUAL NEAR THE ASSEMBLY DIAGRAM (OR MONTH AND YEAR OF PURCHASE IF PRODUCT HAS NO NUMBER).

FOR QUESTIONS PLEASE CALL OUR CUSTOMER SUPPORT: (909) 628 0880 MON-FRI 9AM TO 3PM PST

IMPORTANT SAFETY INFORMATION



GENERAL SAFETY WARNINGS

Read all safety warnings and instructions. Failure to follow the warnings and instructions may result in electric shock, fire and/or serious injury. Save all warnings and instructions for future reference.

SAFETY

The warnings, precautions, and instructions discussed in this instruction manual cannot cover all possible conditions and situations that may occur. It must be understood by the operator that common sense and caution are factors which cannot be built into this product, but must be supplied by the operator. Read carefully and understand all ASSEMBLY AND OPERATION INSTRUCTIONS before operating. Failure to follow the safety rules and other basic safety precautions may result in serious personal injury.

- **Read and understand all instructions.** Failure to follow all instructions may result in serious injury or property damage.
- **DO NOT** allow persons to operate or assemble the product until they have read this manual and have developed a thorough understanding of how it works.
- **DO NOT modify this product in any way.** Unauthorized modification may impair the function and/or safety and could affect the life of the product. There are specific applications for which the product was designed.
- **Keep children and bystanders away from the work area while operating the filter. DO NOT** allow children to handle the product.
- To avoid possible electric shock, special care should be taken since water is employed in the use of this equipment. For each of the following situations, do not attempt repairs yourself; return the appliance or discard the appliance
- If the unit falls into the water, **DO NOT** reach for it. First, unplug it and then retrieve it. If electrical components of the unit get wet, unplug immediately.
- **DO NOT** operate any appliance if it has a damaged cord or plug, or if it is malfunctioning, or if it is dropped, or damaged in any manner.
- Always unplug the unit from the outlet when not in use, before putting or taking off parts, and before cleaning. Never yank the cord to pull plug from outlet. Grasp the plug and pull to disconnect.
- **DO NOT** use this unit for other than intended use. The use of attachments is not recommended by the manufacturer and may cause an unsafe condition.
- **Ground Fault Interrupter Protection**
To comply with the National Electrical Code (NFPA 70), and to provide additional protection from risk of electric shock, this unit should only be connected to a receptacle that is protected by a ground fault circuit interrupter (GFCI).
- **DO NOT** look at an unshielded UV-C globe. Ultra Violet light is harmful to your eyes and may cause blindness.

- **Grounding Instructions:** This appliance must be grounded. In the event of a malfunction or breakdown, grounding will reduce the risk of electric shock by providing a path of least resistance for electric current. This appliance is equipped with a cord having an appliance-grounding conductor and a grounding plug. The plug must be plugged into an appropriate outlet that is installed and grounded in accordance with all local codes and ordinances.
- **Extension Cords**
 - A. Use only extension cords that are intended for outdoor use. These extension cords are identified by the marking “Acceptable for use with outdoor appliances; store indoors while not in use”.
 - B. Use only extension cords having an electrical rating not less than the rating of the product.
 - C. Do not use damaged extension cords.
 - D. Examine extension cord before using and replace if damaged.
 - E. Do not abuse extension cord and do not yank on any cord to disconnect.
 - F. Keep cord away from heat and sharp edges.
 - G. Always disconnect the extension cord from the receptacle before disconnecting the product from the extension cord.
- **WARNING:** To reduce the risk of electrocution keep all connections dry and off the ground. **DO NOT** touch the plug with wet hands.
- **WARNING:** Improper connection of the appliance-grounding conductor can result in a risk of electric shock. Check with a qualified electrician or service representative if you are in doubt whether the appliance is properly grounded. **DO NOT** modify the plug provided with the appliance; if it will not fit the outlet, instead have a proper outlet installed by a qualified technician.
- **DO NOT** use with pumps that exceed 4500 gallons per hour. This could damage the filter.
- **DO NOT** use pumps with flows less than 2500 gal/hr. A minimum of 2500 gallons per hour is necessary to perform the back flush operation.

NOTE: All pressure filters restrict the flow from your pump. Expect about a 45% reduction in the water flow through the filter.
- **DO NOT** submerge the filter in water.
- For your own safety, disconnect from the power supply before any maintenance of any equipment is attempted on the tank or water body.
- **DO NOT** operate the filter if any components of the system, such as the power cable, have been damaged. **DO NOT** operate the filter without water at any time, permanent damage may occur.
- If required, have a qualified electrician install a weather proof power point near to the pond or water feature (within the cable length of the filter).
- **NEVER** operate the filter with integrated UVC with water pressure greater than 0.2bar/2mwh. The height difference between the filter lid and the pressure-free outlet point can be 2m max. The maximum delivery of the pump being used must not exceed 0.5bar/5mwh. Only operate the filter with pressure hoses that are approved for at least 0.2bar. Check and clean the water outlet to the pond on a regular basis.
- **DO NOT** install or store the appliance where it will be exposed to extreme hot or cold temperatures. **DO NOT** use with water above 35 ° C.
- **DO NOT** attempt to repair the electrical appliance yourself. Return to an authorized service centre or place of purchase if a fault occurs, (regular maintenance is not considered repair and is required by user).

FEATURES

Keep your fish healthy and let them thrive in a clean and fresh pond! This powerful filter cleans out harmful algae and growth using a UV light purifier. Transform dirty green pond water into a crystal clear oasis, so your fish can live longer and happier for years to come.

FEATURES

- **VOLTAGE:** 120V/60HZ
- **MAX FLOW RATE:** 4000 GPH
- **UV Lamp Life:** 8,000 hours
- **Overall Dimensions:** 14"(Dia) x 20"(H)
- **Cord Length:** 15'
- **Weight:** 19.8lbs
- Does not include pump
- No assembly required
- Includes inlet and outlet adapters
- Powerful filter for 2500 gallons with a normal fish load, or 1500 gallons with a heavy fish load.
- UV purifier reduces algae by preventing its ability to reproduce, creating a healthy and clear pond.
- Back-flush feature cleans contaminants and debris with ease.
- Flow indicator lets you know when to clean.
- **Includes:** pressure filter with integrated UVC, 1.5" Transparent spiral stepped hose adapter, (2) 1.5" Black spiral stepped hose adapters, 1.5" Black threaded spiral stepped hose adapter, (4) 1.5" union nuts, Glass seal cover, (4) Flat seals, Instructions.



INSTALLATION

- Do not submerge this product in water. The pressure filter should be used in-line, between a pump and a water feature or waterfall. The filter can also be partially buried to help disguise it in your garden.
- Place the filter on a firm and level base, e.g. on a slab. Please make sure that there is unhindered access to the lid in order to be able to carry out maintenance on the filter.
- When the filter is being used at 'filter' mode, the cleaning connection or any drainage hose connected to it must always be sealed with the sealing cap and inserted flat seal in order to prevent the pond from emptying. At the same time the sealing cap acts as a safe guard in case the function switch is accidentally set to 'clean'.
- Make sure the Function switch is always set to 'Filter' when the pump is in operation. The Function switch may only be set to 'Clean' when cleaning the filter sponges with the handle function. Before starting up the filter check that the hoses, sealing cap and tension rings are sitting correctly. Never filter any liquids other than water. Keep the filter out of direct sunlight.

DIAGRAM

A. WATER INLET: The pump is connected to the water inlet with a pressure hose.

B. VORTEX SYSTEM: Suspended matter and bio-sludge are precipitated by the centrifugal affect and gravity.

C. MECHANICAL FILTER: Dirt particles are trapped by the outer surface of the filter sponges before the water flows the entire height of the filter from the edge into the inner chamber of the filter.

D. BIOLOGICAL CLARIFYING: The yellow and blue filter sponges differ in size and density. This creates zones where the water can flow at different speeds.

E. PRE-CLARIFYING POND WATER: As the water flows out it is briefly exposed to ultraviolet radiation under the UVC lamp. This kills off germs and bacteria and inhibits algae growth.

F. WATER OUTLET WITH FLOW INDICATOR: At the water outlet the clarified water is fed back into the garden pond via pressure hose or a watercourse etc.

G. CLEANING CONNECTION: When cleaning the filter a drainage hose can be connected to the cleaning connection which diverts the dirty water into the sewage system or into a flowerbed.

H. FUNCTION SWITCH: The Function Switch is used to switch between normal water discharge into the pond filter and the cleaning connection "Clean" and press it to wash the filter sponge.

I. TURBIDIMETER: If the filter sponge is too dirty, the Turbid will go from green to yellow. This means the sponge needs to be washed out.

CLEAR WATER: Clear water is achieved if the fish or stones can be seen at the bottom of the pond at a depth of 1m.

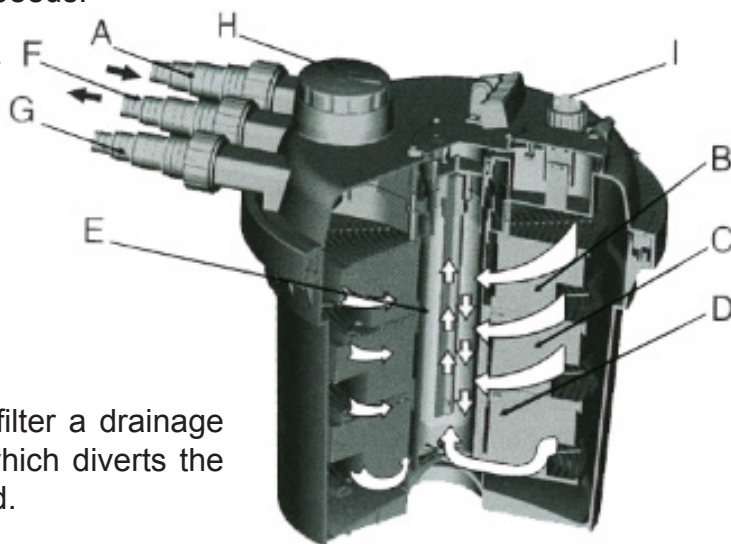

INSTALLATION

POND SIZE / WITH OR WITHOUT FISH

PUMP FLOW RATE	NATURAL POND/NO FISH	KOI POND WITH FISH
770GPH	880 GAL	440 GAL
1210GPH	1320 GAL	660 GAL
1760GPH	1760 GAL	880 GAL
2640GPH	2420 GAL	

The filter system with integrated UVC must be running permanently, 24 hours a day. The UVC lamp must be replaced after 8,000 hours of operation in order to ensure that the filter UVC continues to operate properly.



PRESSURE LOSS DUE TO HEIGHT DIFFERENCE

The selection table allows for a maximum height difference of 1m between the surface of the water and the highest point of the filtering system. If the height difference is greater than 1m, you should use a corresponding pump with more power. For hoses that are longer than 4m, always use hoses that correspond to the upper value of the scale.

In order to avoid pressure loss, cut the spiral stepped hose adapter at the relevant points for each hose. Avoid unnecessary corners and bends which contribute to further pressure loss.

INSTALLING AND CONNECTING THE PRESSURE FILTER

Choose a suitable location for the pressure filter. Install the filter so that it is safe from flooding. Secure your filter so that it won't fall into the pond. Be sure to place it at least 2m from the edge of the pond.

Place the filter on a firm, level base. The filter can also be dug in up to the step on the filter box. Make sure there is unhindered access to the lid in order to be able to carry out work on the filter.

Decide which hose diameter you need based on the selection table. Only operate the filter with pressure hoses that are approved for a pressure of 0.2bar (the maximum pressure of the pump). It is recommended to warm the hose with hot water, pushing it onto the spiral stepped hose adapter and securing it with a hose clip. This makes the connection watertight. To avoid pressure loss, cut the spiral stepped hose adapter at the relevant point to fit each hose.

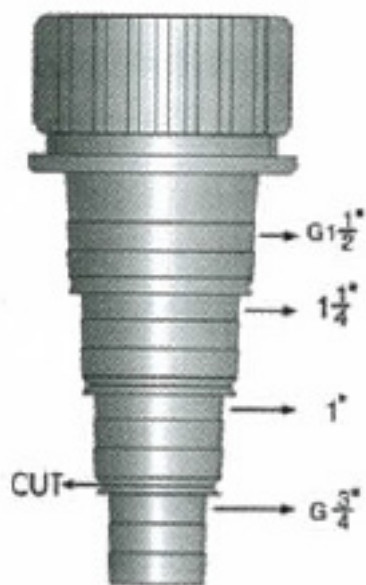

CONNECTION AT THE WATER INLET

Push the union nut onto the black spiral stepped hose adapter. Push/twist the hose on and secure with a hose clip. Insert the flat seal into the union nut and screw tight onto the water inlet nozzle. We recommend diverting the clean water via a small watercourse, for example, instead of feeding it directly back into the pond. This enriches the water with additional oxygen. Connecting to a cleaning connection, you can have a drainage hose permanently connected to the cleaning connection. This allows you to drain the dirty water directly into the sewage system or onto a flower bed.

INSTALLATION

STARTING THE PRESSURE FILTER

Before each start up, check that the connected hoses, sealing cap and tension ring with safety latch are sitting correctly. The function switch must be set to "Filter". It is imperative that you read and follow the following guidelines.



1. Switch on the pump. Caution: The UVC lamp should not be operated without water flowing.
2. After starting the pump, check that all connections are water tight.
3. Plug the filter into the mains. The power indicator should light up blue.

In new installation cases, the pressure filter only reaches full biological cleaning effectiveness after a few weeks. Extensive bacterial activity only starts at temperatures +10 °C and above.

MAINTENANCE AND CLEANING

The pressure filter is mainly maintenance free but the filter sponges should be cleaned regularly. Suspended matter and dirt are deposited on the filter sponges over time. These deposits reduce the effectiveness of the filter. Clean the sponges whenever the water runs dirty or cloudy. To change the sponge, see instructions below.

1. Twist off the sealing cap at the cleaning connection or at the drainage hose that is connected to the cleaning connection. There will be a small flow of water.
2. Turn the function switch clockwise until it clicks in the "Clean" position.
3. Press the "Function" switch hard. This squeezes the filter sponges and cleans them automatically.
4. The filter should now be rinsed. As soon as only clean water can be seen through the transparent spiral stepped hose adapter at the cleaning connection, turn the function switch counter-clockwise until it clicks into the "Filter" position.
5. Screw the sealing cap with the inserted flat seal tightly onto the cleaning connection or the drainage hose that is connected to the cleaning connection.
6. The filter should now be operating again. Check the water flow into the pond.

WASHING THE FILTER SPONGES

If the water flow is too small due to dirty filter sponges and cannot be improved through cleaning with the handle. The filter sponges must be washed or replaced. DO NOT use chemical cleaning agents, doing so may kill off micro-organisms in the filter sponges.

1. Disconnect the mains plug of the filter.
2. Switch off the pump and ensure that it cannot be turned on unintentionally.
3. Remove all hoses by unscrewing the union nuts.
4. Remove the tension ring. To do this, open the tension ring.
5. Lift off the lid with the filter sponge assembly. Place the lid upside down on another clean surface. The filter sponges are laying with the filter face up.
6. The distance between the sponge and filter pad should not be more than 5mm. Circumvolve the filter pad with the arrow in the opposite direction to get the pad out.
7. Pull out the filter sponges and clean with water, squeeze out excess water.
8. Clean out the filter box, lid and lattice pipe, both filter p;ates and the tension ring by spraying them with water. Lift the bypass valve slightly to clean the inlet comb of the filter.

INSTALLATION

9. Clean the lid sealing ring and the edge of the filter box.
10. Push one filter plate with the collar facing upwards, onto the lattice pipe and the cleaning rods.
11. The filter sponges are pushed on from the casing lid, starting with a large blue filter sponge and always alternating with a small yellow filter sponge. The cleaning rods lie in the two openings of the large chamber of filter sponges.
12. Put the filter plate with the collar facing downward. Fasten the cleaning rods flush to the filter plate using two screws.
13. Place the lid seal onto the upper edge of the filter box. To make an easy fit you can wet the seal ring.
14. Place the tension ring onto the edge of the filter box. Place the tension ring onto the edge of the filter box and lid, press down on the lid and click the fastening into place. Push safety latch in.

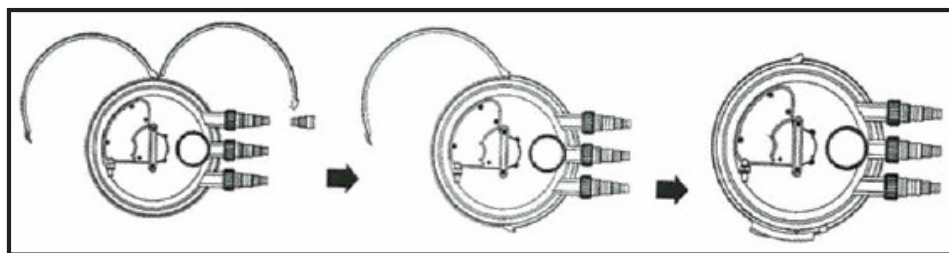

18. Fasten all hoses with flat seals or flow vane to the corresponding connection by screwing the union nuts on tightly. Start the pressure filter on again.

REPLACING THE UVC LAMP

The UVC Lamp must be replaced after 8,000 hours of operation in order to ensure that the filter continues to operate with optimum effectiveness.

1. Unscrew the eight screws of the filter cover and handle. Pull the lamp from the lid of the filter.
2. Pull the UVC lamp and replace it with a new one.
3. Insert the filter UVC in the lid of the filter and screw the eight screws. Start the pressure filter up again.

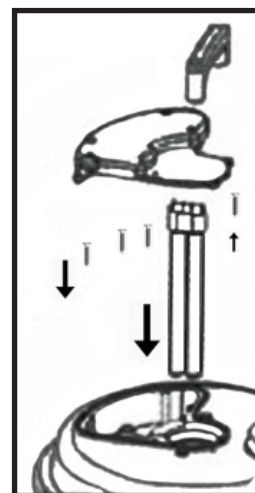

TROUBLESHOOTING

ISSUE	POSSIBLE CAUSE	POSSIBLE FIX
WATER NOT RUNNING CLEAR	Unit is still new	Full effectiveness of biological cleaning is only reached after a few weeks
	Inappropriate pump capacity	Reset the pump capacity
	Water is dirty	Remove algae and leaves from the pond
	Fish population is too large	Keep approx 1kg of fish per 1000 CBM of pond water
	Filter sponges and quartz tubes are dirty	Remove them and clean them
UVC LAMP INDICATOR WONT TUN ON	Mains plug of filter UVC is not connected	Connect the mains plug
	Defective UVC lamp	Replace the UVC lamp
	Faulty connection	Check the electrical connection
	Lamp has no UVC output	Replace the lamp after every 8,000 of operation
	Protective tube not fitted	Replace the UVC lamp
NO WATER DISCHARGE FROM THE POND INLET	Filter UVC overheating	After cooling down, UVC switched on automatically
	Function switch set to "Clean"	Reset Function switch to "filter"
	Mains plug of pump is not connected	Connect the mains plug of the pump
	Pond inlet blocked	Clean the pond inlet

PLEASE READ THE FOLLOWING CAREFULLY

THE MANUFACTURER AND/OR DISTRIBUTOR HAS PROVIDED THE PARTS LIST AND ASSEMBLY DIAGRAM IN THIS MANUAL AS A REFERENCE TOOL ONLY. NEITHER THE MANUFACTURER OR DISTRIBUTOR MAKES ANY REPRESENTATION OR WARRANTY OF ANY KIND TO THE BUYER THAT HE OR SHE IS QUALIFIED TO MAKE ANY REPAIRS TO THE PRODUCT, OR THAT HE OR SHE IS QUALIFIED TO REPLACE ANY PARTS OF THE PRODUCT. IN FACT, THE MANUFACTURER AND/OR DISTRIBUTOR EXPRESSLY STATES THAT ALL REPAIRS AND PARTS REPLACEMENTS SHOULD BE UNDERTAKEN BY CERTIFIED AND LICENSED TECHNICIANS, AND NOT BY THE BUYER. THE BUYER ASSUMES ALL RISK AND LIABILITY ARISING OUT OF HIS OR HER REPAIRS TO THE ORIGINAL PRODUCT OR REPLACEMENT PARTS THERETO, OR ARISING OUT OF HIS OR HER INSTALLATION OF REPLACEMENT PARTS THERETO.

Record Product's Serial Number Here: _____

Note: If product has no serial number, record month and year of purchase instead.

Note: Some parts are listed and shown for illustration purposes only and are not available individually as replacement parts.



SAVE THESE INSTRUCTIONS.



Questions, problems, missing parts?

Before returning to your retailer, our exceptional customer service is available.

Call us Tel: **909 628 0880**

Hour : **9am To 3pm PST (Monday to Friday)**

Email : **customer@xtremepowerusa.com**