

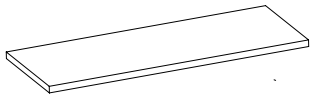

# 2 Tier Iron Pipe Wall Shelving

MODEL NUMBER  
IPWS-2T

## PARTS LIST



Ax2PCS

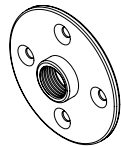

Bx4PCS

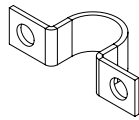

Cx4PCS

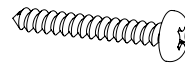

Dx16PCS



Ex16PCS

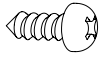

Fx8PCS

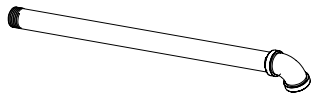

Gx4PCS

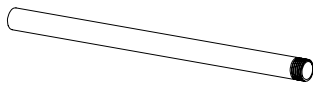

Hx2PCS

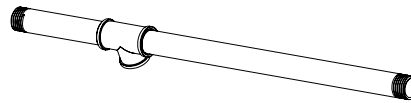

Ix2PCS

## TOOLS REQUIRED

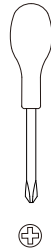
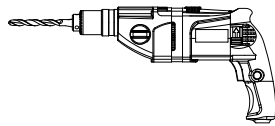
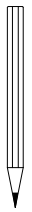

## ASSEMBLY INSTRUCTION

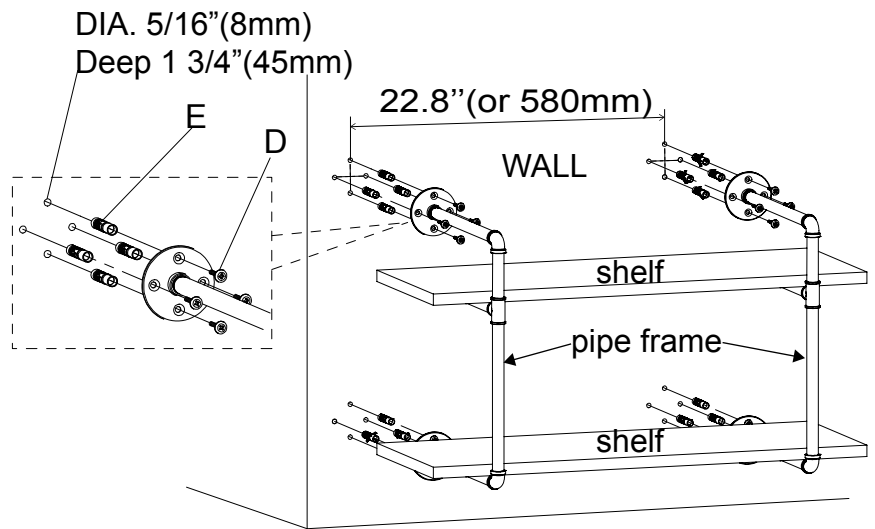
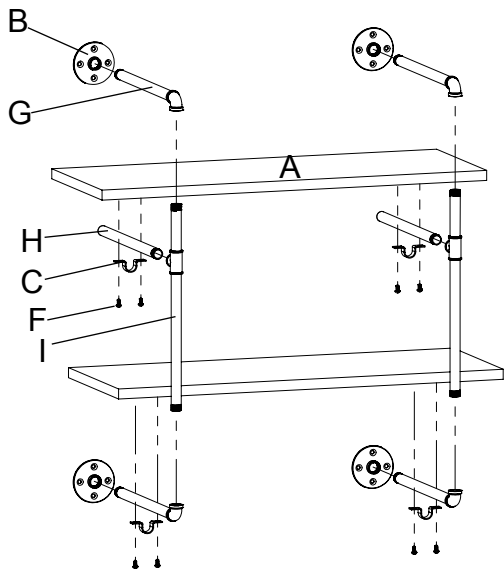

Here are two options to complete the installations:

### Option 1:

Step 1: Install two pipe frames separately with parts (B)(G)(H)(I).

Step 2: Screw shelves (A) on the pipe frames with screws(F) and shelf brackets(C).

Step 3: Mark a line on the wall using a gradienter. Mark the wall studs location on the wall.

Mount the frames to the studs. Drilling DIA. 5/16"(8mm) Deep 1 3/4"(45mm) into the wall and fitting anchor (E). Mount the pipe frames to the studs. Screw pipe frames with (D).

### Option 2:

Step 1: Install two pipe frames separately with parts (B)(G)(H)(I).

Step 2: Mount two pipe frames to the wall with the center-to-center distance 22.8" (or 580mm).

Step 3: Assemble shelves (A) on the pipe frames with screws(F) and shelf brackets(C).