

**16602-T**



***Call Us First!***

***DO NOT RETURN TO STORE.***

For immediate help with assembly or product information  
call our toll-free number:

**1-888-827-9056**

or email:

***customerservice@backyardproductsllc.com***

Our staff is ready to provide assistance.

**April through October M - F 8:00 AM to 7:00 PM EST**

**Saturday 8:30 AM to 4:30 PM EST**

**November through March M - F 8:00 AM to 5:00 PM EST**

***ANTES DE DEVOLVERLO, ¡LLÁMENOS!***

Si desea más información sobre el montaje, llámenos sin coste  
adicional alguno al siguiente teléfono:

**+1-888-827-9056**

o correo electrónico:

***customerservice@backyardproductsllc.com***

Nuestro personal le proporcionará toda la ayuda que necesite.

**Abril por octubre M - F 8:00 EST a 7:00 P.M. EST**

**el sábado 8:30 EST a 4:30 P.M. EST**

**noviembre por marzo M - F 8:00 EST a 5:00 P.M. EST**

(This page intentionally left blank.)

(Esta página está intencionado en blanco.)

**Customer Service**  
(Servicio al cliente)  
1-888-827-9056  
1000 Ternes Drive  
Monroe, MI 48162

# Premier / Heritage Series

## 10' Wide Gambrel

### Cubierta a la holandesa de 10'

Includes 10'x8' (305x244 cm), 10'x12' (305x366 cm), 10'x16' (305x488 cm) Building Instructions

Instrucciones para edificios de 10'x8' (305x244 cm), 10'x12' (305x366 cm), 10'x16' (305x488 cm)

**Tools required**  
(Herramientas necesarias)

- Hammer (Martillo)
- Phillips Screwdriver (Desarmador cruz)
- Level (Nivel)
- Ladder (Escalera)
- Pencil (Lápiz)
- Tape Measure (Cinta métrica)
- Utility Knife (Navaja)
- Paint Tools (Herramientas para pintar)
- Caulk Gun (Pistola para masillado)
- Hand Saw (Sierra portátil)
- Wood Glue (Pegamento para madera)

**Optional Tools**  
(Herramientas opcionales)

- Electric Drill w/ #2 Phillips Tip (Taladro eléctrico Broca "Phillips")
- Chalk Line (Línea de marcar)
- Square (Escuadra)
- Nail Pouch (Bolsillo para clavos)

**- BEFORE YOU BEGIN -**

**First...**

- Check with your local building authority before erecting.
- Read instructions thoroughly before you begin.

**Building Codes**

- Our buildings are designed to meet most local and national U.S. codes and are not meant to be used for living space.
- General construction drawings can be provided.
- Stamped certified drawings can be provided for a fee. Call for details.

**Check All Parts**

- If a part is missing, circle the part in question and call.
- Please note the primer color may vary on siding and trim parts. This is a factory applied primer intended for preparing your building for painting. This is NOT a finish coat. This primer color variation will not affect the look of your building once painted.

**Important**

- Lumber is graded from one side, use most attractive face to the outside.
- In a drawing, a dotted line represents a part hidden from view (like a part under a panel).

**Assistance required**

- Assistance is necessary to handle, fit, and secure some components.

**Squareness is very important!**

- Keep 90° corners and 90° perpendiculars throughout the assembly to ensure all components fit together.

**Check foundation size**

- Before starting on your foundation, make sure you are building the correct size foundation for your building.

**Always wear OSHA-APPROVED safety glasses throughout assembly process.**

**- ANTES DE EMPEZAR -**

**Primero...**

- Consulte la autoridad de construcción local antes de construir el edificio.
- Lea las instrucciones completamente antes de empezar.

**Códigos de Construcción**

- Hemos diseñado nuestros edificios a que conformen con todos los códigos de construcción locales y nacionales. Los edificios no están proyectados como residencia.
- Se disponen planes generales de construcción.
- Se disponen de planes certificados por un precio. Estos planes no garantizan la aprobación de los autoridades locales.

**Compruebe todas las piezas**

- Si falta una pieza, indícala con un círculo y llámenos.
- Aviso: El color del imprimador puede variar en la cobertura y las partes de la moldura. Este imprimador se aplica en la fábrica y es para preparar su edificio para pintar. NO es una capa de pintura terminada. La variación en el color del imprimador no afectará la apariencia de su edificio al pintarlo.

**Importante**

- La Madera está elaborada en un solo lado. Use el lado más atractivo en el exterior.
- Si falta una pieza, póngale un círculo y llámenos.
- En un dibujo una línea punteada representa una pieza no vista (por ejemplo, una pieza debajo de un panel)

**Ayuda requerido**

- Seleccione un sitio nivelado.
- Será necesario pedir ayuda para manejar, unir, y reforzar algunas piezas.

**¡Es preciso escuadrar el edificio!**

- Mantenga ángulos de 90° en las esquinas y los perpendiculares durante la construcción para asegurar que todas las piezas se unen correctamente.

**Compruebe las dimensiones de la cimentación.**

- Compruebe que las dimensiones de la cimentación son las correctas para el edificio.

**Siempre lleve gafas de seguridad aprobadas por OSHA durante la construcción.**

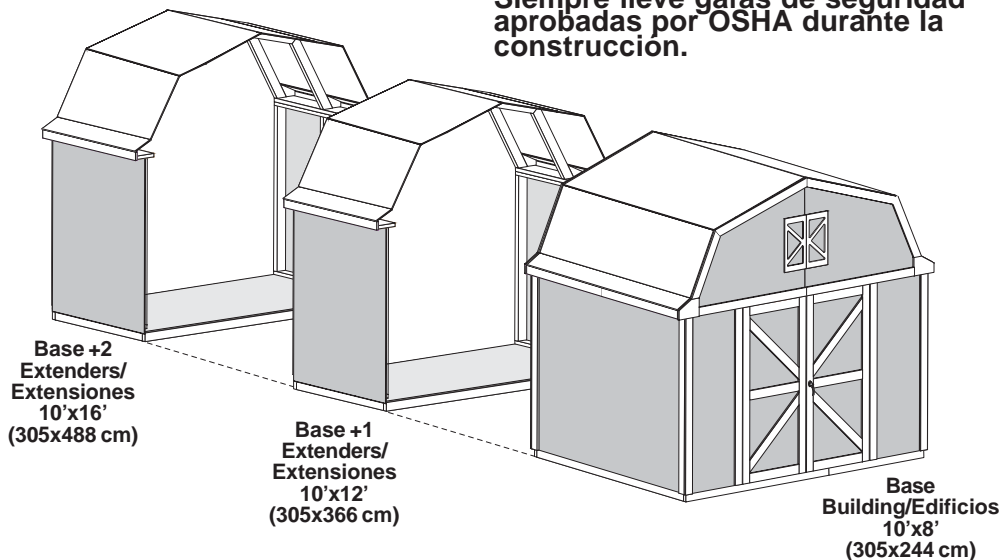



We manufacture kits from select construction grade lumber and engineered wood products. Construction grade lumber, a product cut from trees, has many natural characteristics and blemishes that may be present in some of the pieces you receive in your kit. Natural characteristics and blemishes in construction lumber may include knots, torn wood grain along edges, minor cracks/splits, twists, limited bark along edges and pitch pockets that may exude sap. Be assured that the individual parts have been cut and inspected to remove as many of the wood's natural, less appealing characteristics as possible. These characteristics and/or blemishes will not affect the strength, durability, or structural integrity of the finished product. Generally, the exterior trim parts selected for your kit are graded from only one side and should be installed with the most attractive side outward. Our limited warranty does not cover the natural characteristics and blemishes that occur with construction grade lumber products.

Fabricamos nuestros equipos de madera elaborada y de productos maquinados de madera. La madera elaborada, producto de árboles, tiene muchas características e imperfecciones naturales que puedan tener algunas piezas contenidas en el equipo. Estas imperfecciones y características pueden incluir nudos, grano rasgado sobre el borde, rajaduras pequeñas, torsiones, cortezas en el borde, y bolsos que exuden savia. Aseguramos que hemos cortado e inspeccionado las partes individuales para eliminar las características naturales menos atractivas posibles. Estas características y/o imperfecciones no afectarán la fuerza, durabilidad ni la integridad estructural del producto final. Por lo general, las piezas de moldura exterior seleccionadas para su equipo se elaboran de un solo lado y deben ser instaladas con la parte más atractiva por fuera. Nuestra garantía limitada no cubre las características e imperfecciones que ocurren con los productos de madera elaborada.

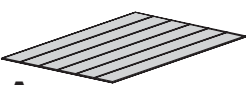
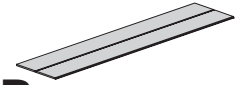
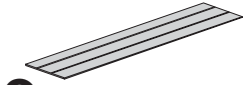
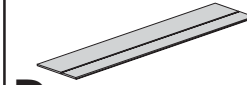

**10' X 8' (305 x 244 cm)  
PARTS LIST**

**10' X 8' (305 x 244 cm)  
LISTA DE PIEZAS**

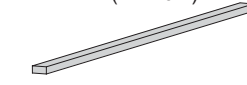
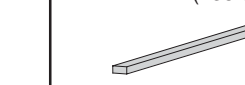

**MURO**

<p>3/8"x48"x72" (.9x122x183 cm)</p>  <p><b>A</b> x6</p>	<p>3/8"x15-7/8"x72" (.9x40x183 cm)</p>  <p><b>B</b> x2</p>	<p>3/8"x23-7/8"x72" (.9x61x183 cm)</p>  <p><b>C</b> x1</p>	<p>3/8"x11-7/8"x72" (.9x30x183 cm)</p>  <p><b>D</b> x2</p>	<p>2x8x92-1/2" (235 cm)</p>  <p><b>XB</b> x2</p>
--	---	---	--	---

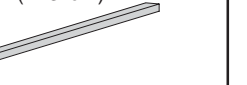

**WALLS**

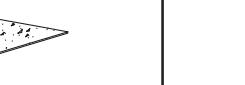
<p>2x4x96" (244 cm)</p>  <p><b>TP</b> x2</p>	<p>2x4x92-5/8" (235 cm)</p>  <p><b>UL</b> x8</p>	<p>2x4x68" (173 cm)</p>  <p><b>UM</b> x22</p>	<p>2x4x24" (61 cm)</p>  <p><b>RL</b> x6</p>
---	---	--	---

**TECHO**

<p>7/16"x48"x96" (1.1x122x244 cm)</p>  <p><b>F</b> x2</p>	<p>7/16"x28-1/2"x96" (1.1x72x244 cm)</p>  <p><b>G</b> x2</p>	<p>7/16"x6-7/8"x96" (1.1x17x244 cm)</p>  <p><b>H</b> x2</p>
--	---	--

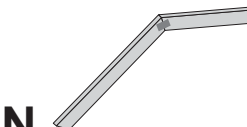

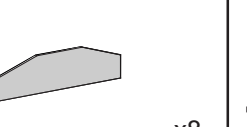

**ROOF**

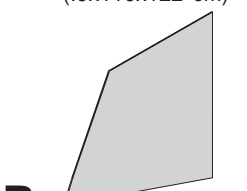
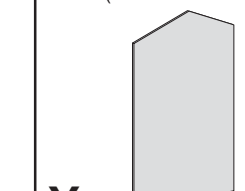
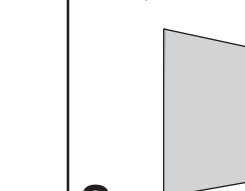
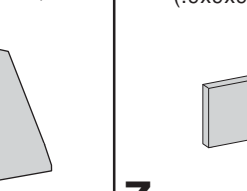
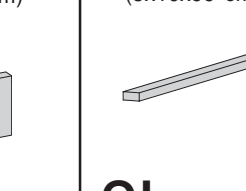
<p>Rafter Viga</p>  <p><b>N</b> x10</p>	<p>Soffit Block Bloque del soffito</p>  <p><b>P</b> x10</p>	<p>Gusset Placa de unión</p>  <p><b>Q</b> x8</p>	<p>2x4x96" (244 cm)</p>  <p><b>TP</b> x3</p>
--	--	---	--



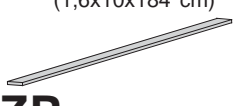
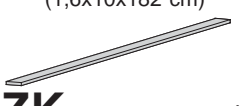

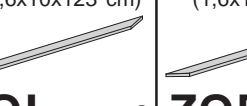
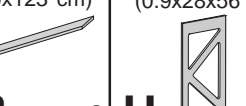
**GABLE**

<p>3/8"x43-3/8"x48" (.9x110x122 cm)</p>  <p><b>R</b> x2</p>	<p>3/8"x23-7/8"x47-1/8" (.9x61x120 cm)</p>  <p><b>Y</b> x2</p>	<p>3/8"x43-3/8"x48" (.9x110x122 cm)</p>  <p><b>S</b> x2</p>	<p>3/8"x3-1/2"x3-1/2" (.9x9x9cm)</p>  <p><b>Z</b> x4</p>	<p>2"x4"x39" (5x10x99 cm)</p>  <p><b>QL</b> x4</p>
---	--	---	---	--

**MOLDURA**

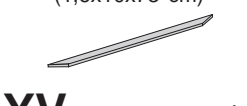
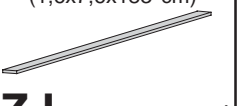
<p>5/8x4"x72-3/8" (1,6x10x184 cm)</p>  <p><b>ZP</b> x2</p>	<p>5/8x4"x71-5/8" (1,6x10x182 cm)</p>  <p><b>ZK</b> x4</p>	<p>5/8x4"x54-9/16" (1,6x10x139 cm)</p>  <p><b>YZ</b> x4</p>	<p>5/8x4"x48-5/16" (1,6x10x123 cm)</p>  <p><b>ZQL</b> x2</p>	<p>5/8x4"x48-5/16" (1,6x10x123 cm)</p>  <p><b>ZQR</b> x2</p>	<p>3/8x11x22" (0.9x28x56 cm)</p>  <p><b>U</b> x2</p>
---	---	--	--	---	---



**TRIM**

<p>5/8x4x28-7/8" (1,6x10x73 cm)</p>  <p><b>YV</b> x4</p>	<p>5/8x3x72" (1,6x7,6x183 cm)</p>  <p><b>ZJ</b> x4</p>	<p>5/8x4x24-3/8" (1,6x10x62 cm)</p>  <p><b>ZZ</b> x2</p>	<p>7-11/16x10-1/16" (19x26 cm)</p>  <p><b>TL</b> x2</p>	<p>7-11/16x10-1/16" (19x26 cm)</p>  <p><b>TR</b> x2</p>	<p>5/8x4x72" (1,6x10x183 cm)</p>  <p><b>ZO</b> x1</p>
---	---	---	---	--	--

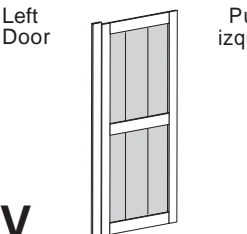
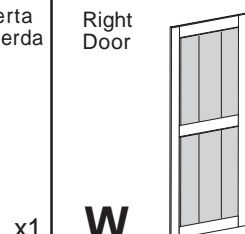
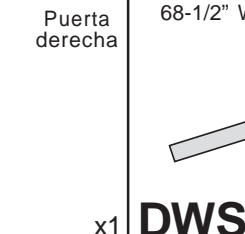
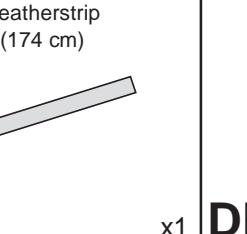
**PUERTA**

<p>Left Door Puerta izquierda</p>  <p><b>V</b> x1</p>	<p>Right Door Puerta derecha</p>  <p><b>W</b> x1</p>	<p>68-1/2" Weatherstrip (174 cm)</p>  <p><b>DWS</b> x1</p>	<p>68-1/2" Metal Door Edge "L" (174 cm)</p>  <p><b>DEL</b> x2</p>
--	---	---	---

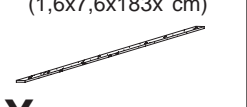
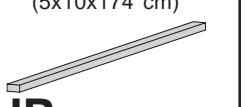
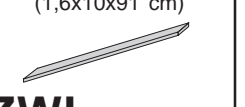

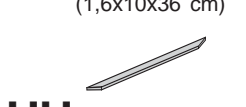









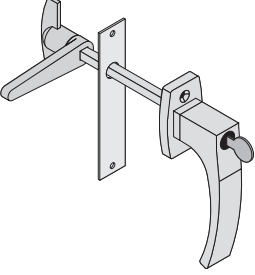

**DOOR**

<p>5/8"x3"x72" (1,6x7,6x183x cm)</p>  <p><b>X</b> x1</p>	<p>2"x4"x68-1/2" (5x10x174 cm)</p>  <p><b>UP</b> x2</p>	<p>5/8x4x35-1/4" (1,6x10x91 cm)</p>  <p><b>ZWL</b> x2</p>	<p>5/8x4x35-1/4" (1,6x10x91 cm)</p>  <p><b>ZWR</b> x2</p>	<p>5/8x4x14" (1,6x10x36 cm)</p>  <p><b>HU</b> x4</p>
---	--	--	---	---

**HARDWARE | FERRETERÍA**

**10' X 8' (305 x 244 cm)  
PARTS LIST**

**10' X 8' (305 x 244 cm)  
LISTA DE PIEZAS**

		Actual Size	Dimensiones verdaderas	
	x2	3" (7.6 cm)		x262
	x2	2" (5.0 cm)		x639
		2" (5.0 cm)		x230
	x1	1-1/2" (3.8 cm)		x188
		3" (7.6 cm) ⊕		x18
		2" (4.1 cm) ⊕		x12
		1-5/8" (4.1 cm) ⊕		x10
		1" (2.5 cm) ⊕		x59
1" (2.5cm) 	x2	1" (2.5 cm) ⊕		x34
1-1/4" (3cm) 	x2	3/4" (1.9 cm) ⊕		x24



**WALL | MURO**

**10' X 4' (305 x 122 cm)  
EXTENDER PARTS LIST**

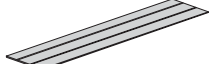
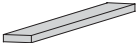
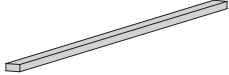
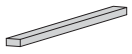

**10' X 4' (305 x 122 cm)  
LISTA DE PIEZAS DE EXTENSIÓN**

3/8"x48"x72" (.9x122x183 cm) 	x1	3/8"x23-7/8"x72" (.9x61x183 cm) 	x2	2x8x48" (5x20x122 cm) 	x2	2x4x68" (173 cm) 	x4	2x4x48" (122 cm) 	x4
<b>A</b>		<b>C</b>		<b>XE</b>		<b>UM</b>		<b>SP</b>	

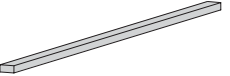

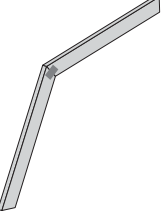

**ROOF | TECHO**

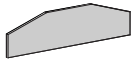
7/16"x47-7/8"x48" (1.1x122x122 cm) 	x2	7/16"x28-1/2"x48" (1.1x72x122 cm) 	x2	7/16"x6-7/8"x48" (1.1x17x122 cm) 	x2	2x4x96" (244 cm) 	x2
<b>J</b>		<b>K</b>		<b>L</b>		<b>TP</b>	

**TRIM | MOLDURA**

5/8x4x48" (1,6x10x122 cm) 	x2	Rafter Viga 	x4	Soffit Block Bloque del soffito 	x4	Gusset Placa de Union 	x4
<b>ZT</b>		<b>N</b>		<b>P</b>		<b>Q</b>	

**HARDWARE | FERRETERÍA**

Actual Size	Dimensiones verdaderas
 x 72 3" (7.6 cm)	 x 198 2" (5.0 cm)
⊕  x 4 3" (7.6 cm)	 x 12 2" (5.0 cm)
	 x 48 1-1/2" (3.8 cm)

# IMPORTANT!!!

## Building Tip

FOR THE BEST LOOKING FINISHED PRODUCT WE RECOMMEND THAT YOU INSPECT, SORT AND LAY OUT MATERIALS PRIOR TO BEGINNING ASSEMBLY OF YOUR BUILDING

# IMPORTANTE!!!

## Consejo

CON EL FIN DE OBTENER EL PRODUCTO ACABADO DE MEJOR ASPECTO RECOMENDAMOS QUE INSPECCIONE, CLASIFIQUE Y ORGANICE LOS MATERIALES ANTES DE EMPEZAR A MONTAR SU EDIFICIO

## HELPFUL MATERIAL NOTICE

## AVISO ÚTIL SOBRE LOS MATERIALES

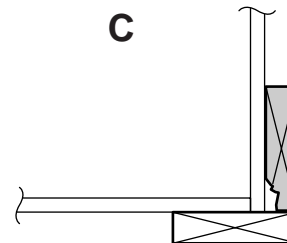
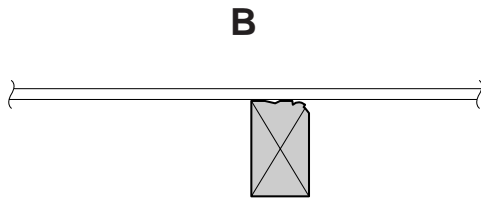
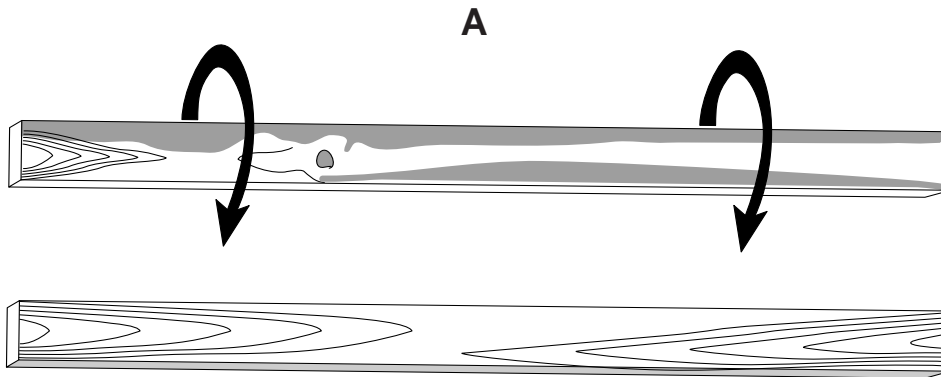

Wood is a natural product that has inherent blemishes. All interior framing is graded for structural strength and not appearance. Exterior trim is graded for one good side per industry standards.

- Blemishes can be easily installed to provide the best appearance. (Fig. A)
- Install wall framing with any blemished sides toward the siding and facing rear of building. (Fig. B)
- Install corner trim, gable trim and fascia with any blemished sides toward the siding material. (Fig. C)

Always install the material leaving the best edge and best surface visible.

Please remember that these blemishes in no way negatively affect the strength or integrity of our product.

La madera es un producto natural que tiene defectos inherentes. Todo la estructura interior ha sido aprobada por ofrecer una resistencia estructural y no por su aspecto. La guarnición exterior ha sido aprobada por tener un buen lado según las normas de la industria.

- La parte con defectos puede instalarse fácilmente de modo que el edificio tenga el mejor aspecto. (Fig. A)
- Instale el entramado de la pared con los lados con defectos apuntando hacia los costados y haciendo frente a la parte trasera del edificio. (Fig. B)
- Instale la guarnición de las esquinas, la guarnición de los hastiales y las impostas con los lados con defectos apuntando hacia el material lateral. (Fig. C)

Instale siempre el material dejando visibles el mejor borde y la mejor superficie.

Recuerde que estos defectos no afectan de forma negativa la resistencia o la integridad de nuestros productos.

Please feel free to call our Consumer Help Line - Toll Free  
**1-888-827-9056**

April through October M - F 8:00 AM to 7:00 PM EST

Saturday 8:30 AM to 4:30 PM EST

November through March M - F 8:00 AM to 5:00 PM EST

Llame de forma gratuita a nuestra línea de ayuda al  
consumidor

**1-888-827-9056**

Abril por octubre M - F 8:00 EST a 7:00 P.M. EST

el sábado 8:30 EST a 4:30 P.M. EST

noviembre por marzo M - F 8:00 EST a 5:00 P.M. EST

## FOUNDATION OPTIONS

(Not supplied with kit)

YOU MUST ASSEMBLE YOUR BUILDING ON A WOOD FLOOR OR CONCRETE SLAB.

### SITE PREPARATION

- Site must be properly leveled.
- Site should have natural drainage and no standing water

## OPCIONES PARA LA CIMENTACIÓN

(No incluidas)

HAY QUE CONSTRUIR EL EDIFICIO SOBRE UN BASE DE MADERA O DE CONCRETO.

### PREPARACIÓN DEL SITIO

- El sitio debe de estar nivelado correctamente.
- Instale una barrera contra yerbajos debajo de la estructura.

A) Purchase our optional Floor Kit or build your own wood floor.

A) Compre nuestro equipo opcional para el suelo o construya su propio suelo de madera.

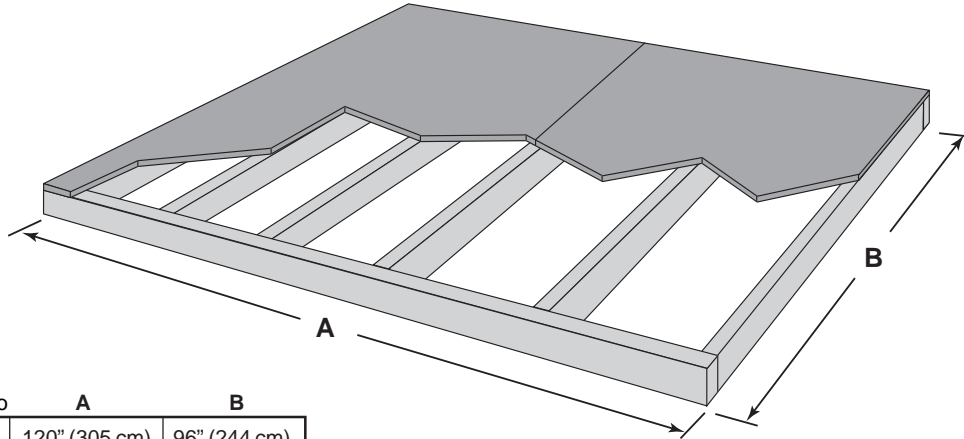

Building Size Dimensiones del edificio	A	B
10' x 8' (305 x 244 cm)	120" (305 cm)	96" (244 cm)
10' x 12' (305 x 366 cm)	120" (305 cm)	144" (366 cm)
10' x 16' (305 x 488 cm)	120" (305 cm)	192" (488 cm)

Important: Square floor and level to ground before beginning assembly of building.

Importante: Asegure que el suelo está nivelado y escuadrado antes de construir el edificio.

## B) Concrete Slab Foundation

## B) Base en losa de concreto

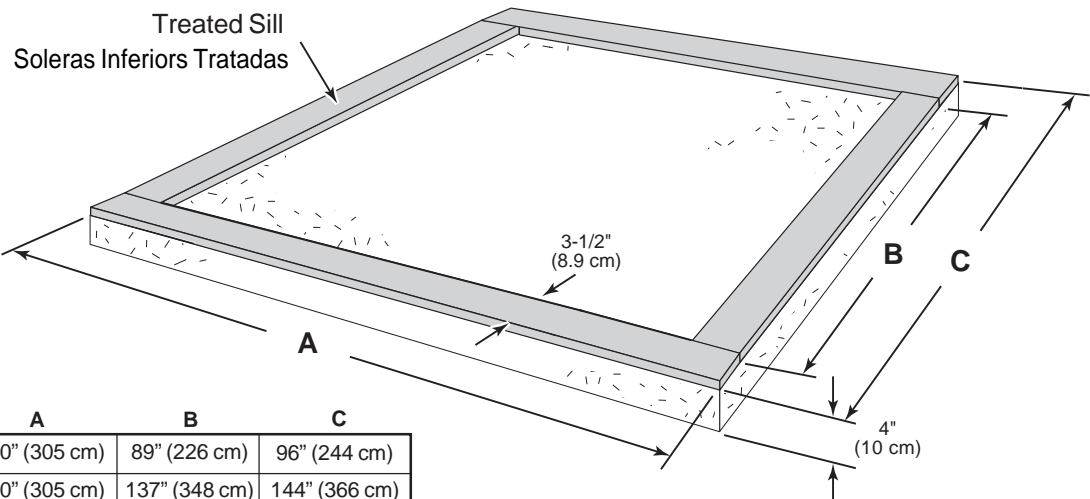

Building Size Dimensiones del edificio	A	B	C
10' x 8' (305 x 244 cm)	120" (305 cm)	89" (226 cm)	96" (244 cm)
10' x 12' (305 x 366 cm)	120" (305 cm)	137" (348 cm)	144" (366 cm)
10' x 16' (305 x 488 cm)	120" (305 cm)	185" (470 cm)	192" (488 cm)

Fasten treated 2x4 sill plates to slab using approved concrete anchors. (Treated sill plates and fasteners not included.)

Fije las soleras inferiores tratadas 2x4 a la losa con anclajes de concreto aprobados. (Las soleras y los anclajes no están incluidos.)



**Before proceeding, determine desired door location and build door wall first.**



**Antes de continuar determine la posición de la puerta y construya el muro con la puerta primero.**

**BUILD WALL NUMBERS SPECIFIED  
WALL NUMBER EQUALS PAGE NUMBER**

**CONSTRUYA LOS NÚMEROS DE LOS MUROS ESPECIFICADOS  
EL NÚMERO DEL MURO CORRESPONDE AL NÚMERO DE LA PÁGINA.**

**10' X 8' (244x244 cm)**

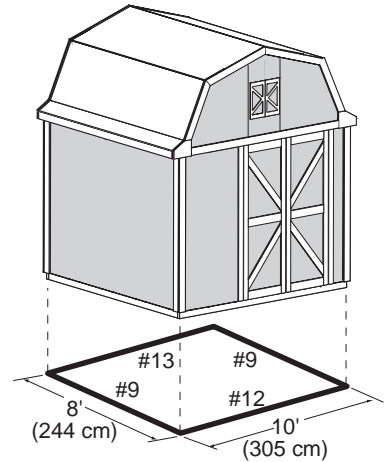
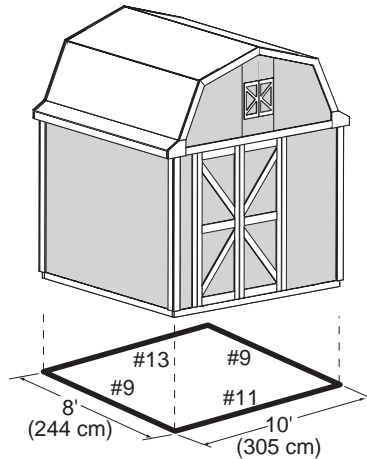
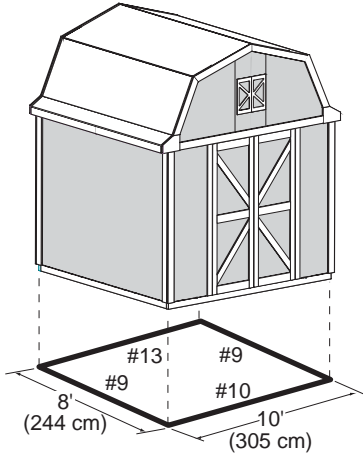

**10' X 12' (305x366 cm)**

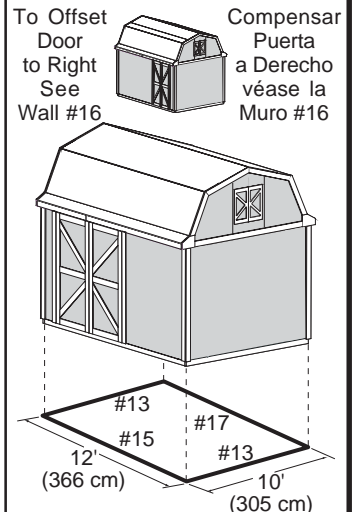
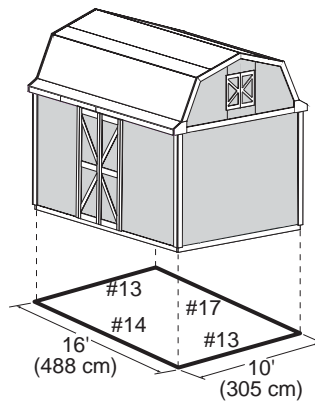
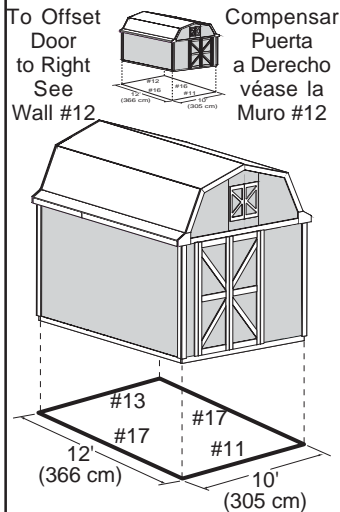
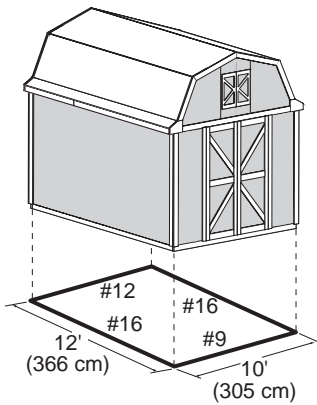

**10' X 16' (305x488 cm)**

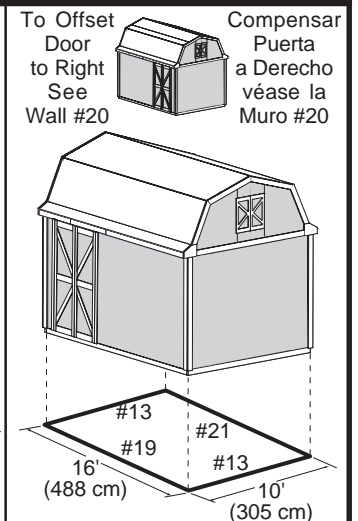
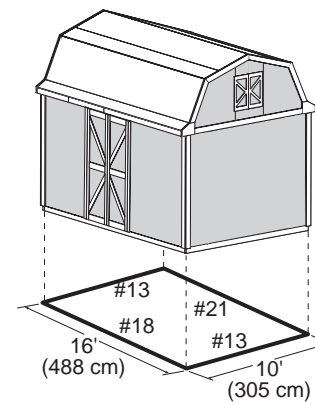
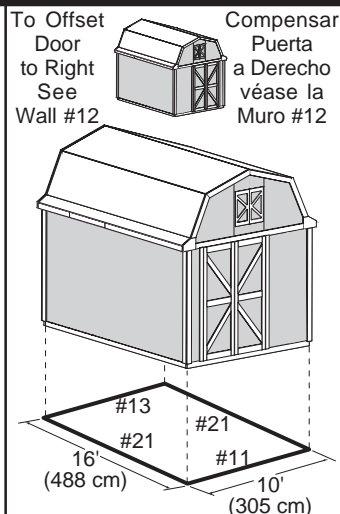
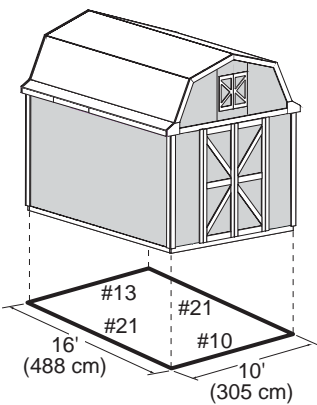



# IMPORTANT!!!

## Building Tip

YOUR BUILDING CAN BE CONFIGURED IN A VARIETY OF WAYS. BEFORE ERECTING WALLS, REFER TO PAGE 5 TO ENSURE YOU BUILT THE RIGHT WALLS FOR YOUR BUILDING.

# IMPORTANTE!!!

## Consejo

ES PRECISO ALINEAR LOS PANELES DE LOS MUROS Y DEL TECHO ANTES DE CLAVARLOS COMPLETAMENTE PARA ASEGURAR LA ESCUADRA.

## Erecting the Walls

Make sure all walls are built as shown below.  
**BUILD DOOR WALL FIRST.**

## Construyendo los Muros

Asegure que se construyan los muros como en los dibujos abajo  
**CONSTRUYA EL MURO CON PUERTA PRIMERO**

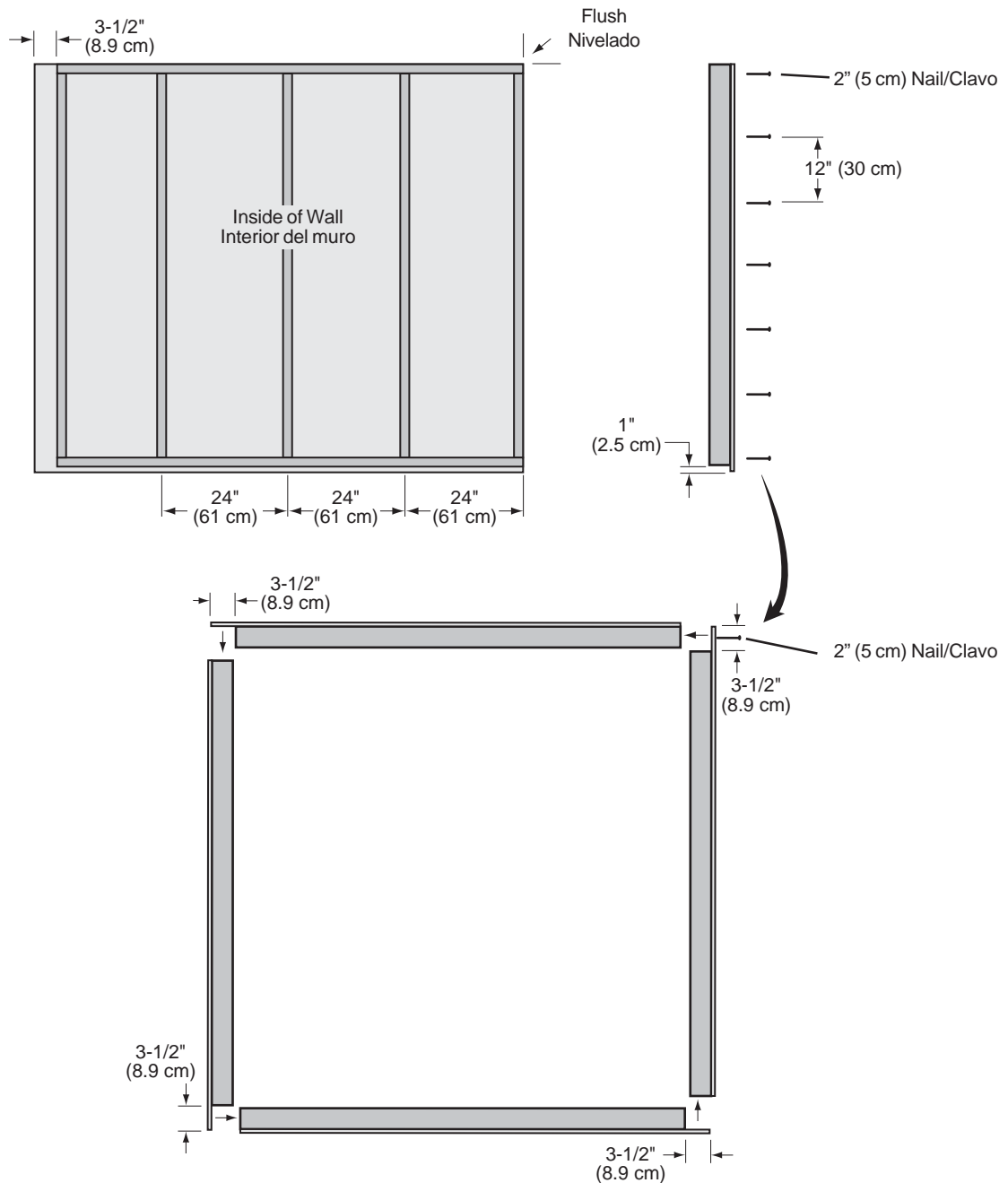

# IMPORTANT!!!

## Building Tip

YOU MAY NEED TO RACK YOUR WALL PANELS AND ROOF PANELS TO ENSURE SQUARENESS BEFORE COMPLETELY NAILING

# IMPORTANTE!!!

## Consejo

ES PRECISO ALINEAR LOS PANELES DE LOS MUROS Y DEL TECHO ANTES DE CLAVARLOS COMPLETAMENTE PARA ASEGURAR LA ESCUADRA.

### Racking a Wall

### Alineando un Muro

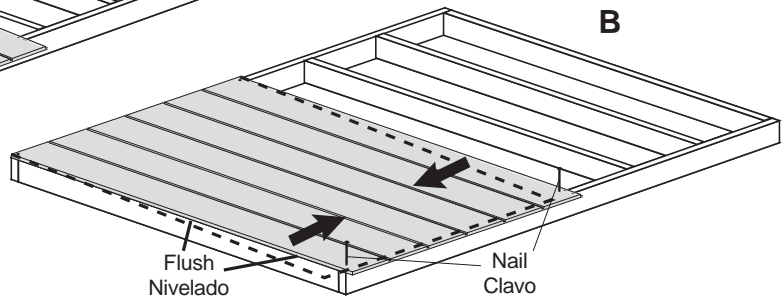
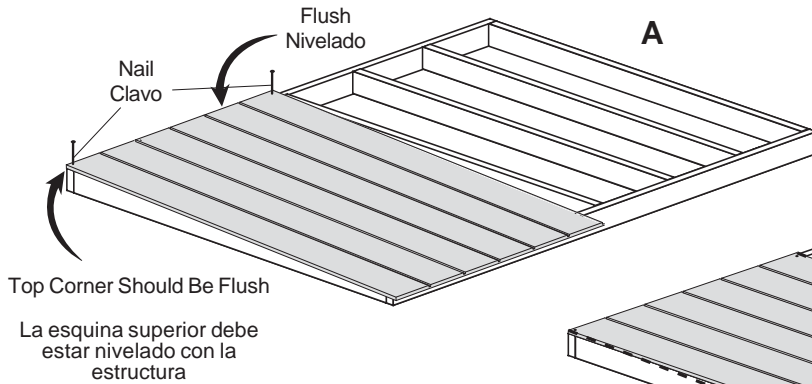

When building walls, always apply panel at far left first. Position panel flush with top of wall frame and nail in upper corners as shown. Rack wall square by moving lower end of wall panel right or left until panel is flush with framing along left edge and secure with one nail in each lower corner. Continue nailing as instructed.

Al construir los muros, siempre fije primero el panel hasta la izquierda extrema. Posicione el panel nivelado con la parte superior de la estructura del muro y clávelo en la esquina superior como en el dibujo. Alinee nivelado el muro por mover el lado inferior a la derecha o a la izquierda hasta que el panel esté nivelado con la estructura a lo largo del borde izquierda. Fije con un clavo en cada esquina inferior.

### Racking a Roof

### Alineando un techo

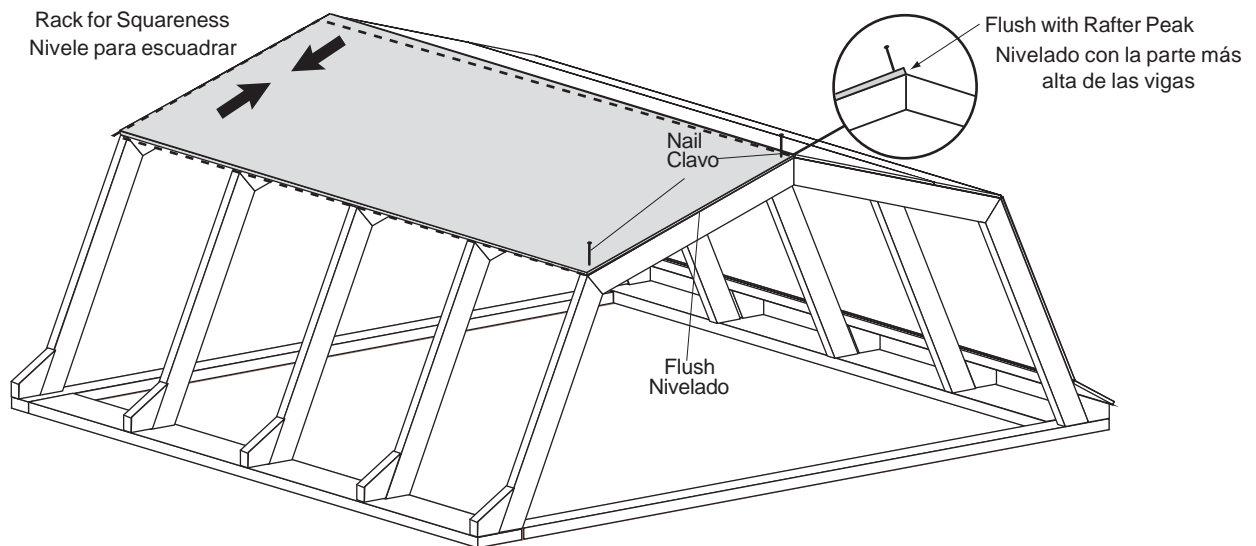

Position panel flush with outside front edge of rafter and nail in two corners as shown. Rack panel square by moving opposite end up or down until panel is flush along peak of rafters and secure with one nail in each corner. Ensure spacing of center rafters and nail as instructed.

Posicione los paneles nivelados con el borde delantero exterior de la viga y clave en las dos esquinas como en el dibujo. Alinee escuadra el panel por mover los extremos opuestos arriba o abajo hasta que el panel esté nivelado a lo largo del punto más alto de las vigas, y fíjelo con un clavo en cada esquina. Compruebe el espacio de las vigas centrales y clave como indicado.

WALL #9

3"(7.6 cm)

x 20

MURO #9

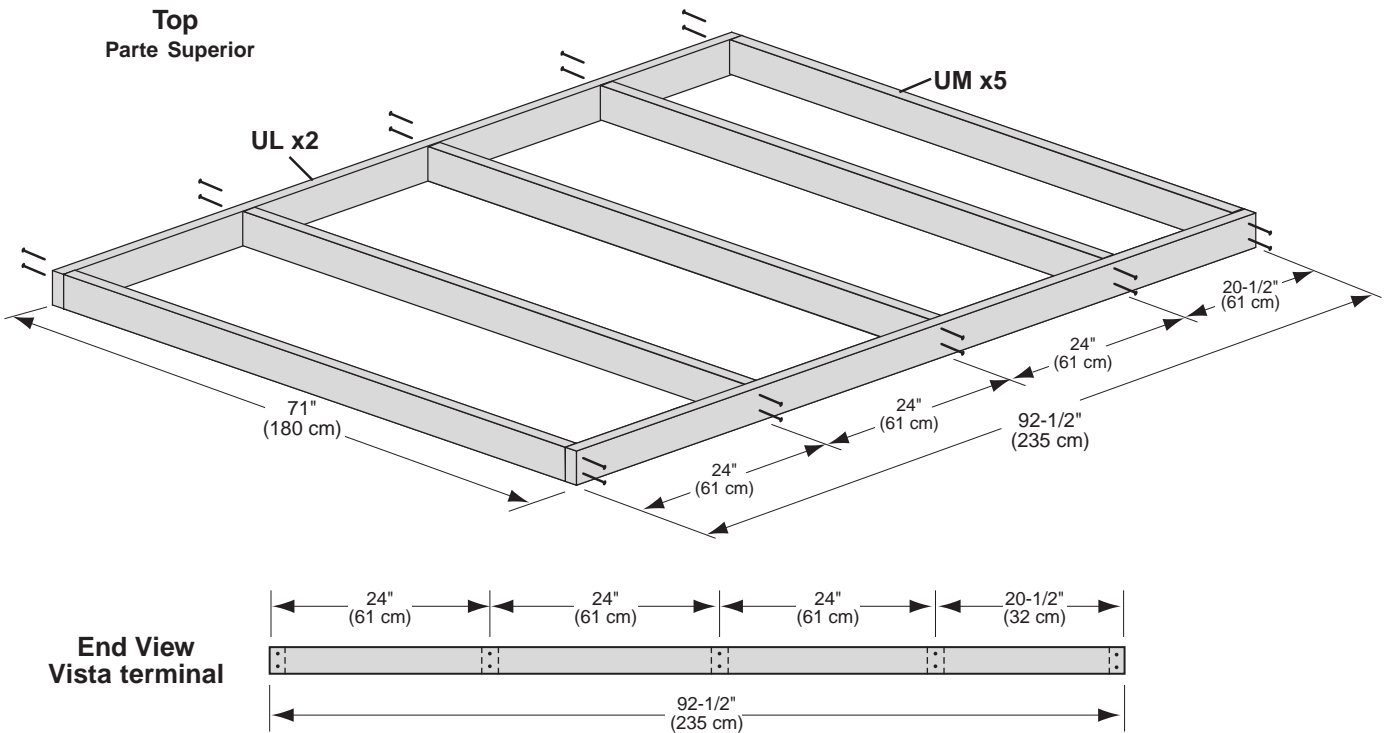

WALL #9

2"(5 cm)

x 90

MURO #9

See Page 8 For Building Tip!!!

¡Ver la página 8 para un consejo!!!

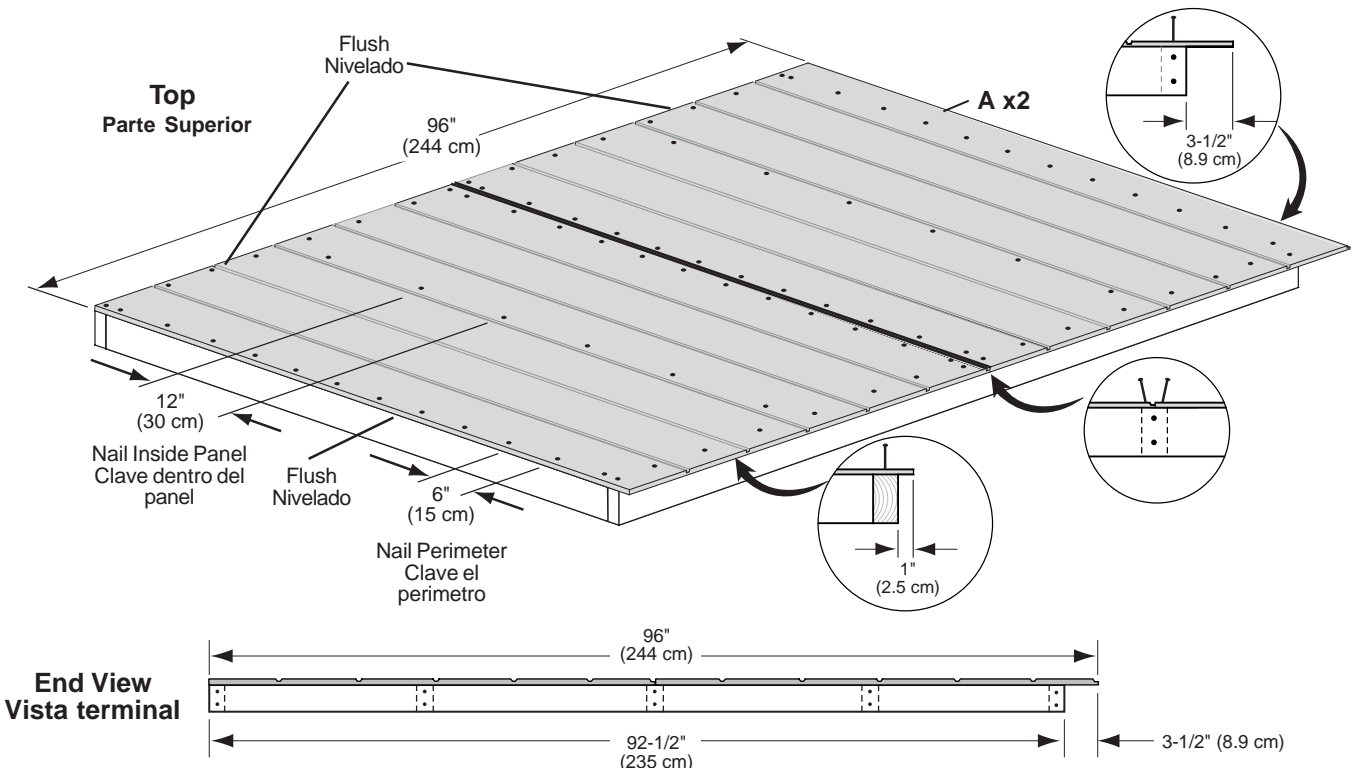

# WALL #10

3"(7.6 cm)

x 28

# MURO #10

Top  
Parte Superior

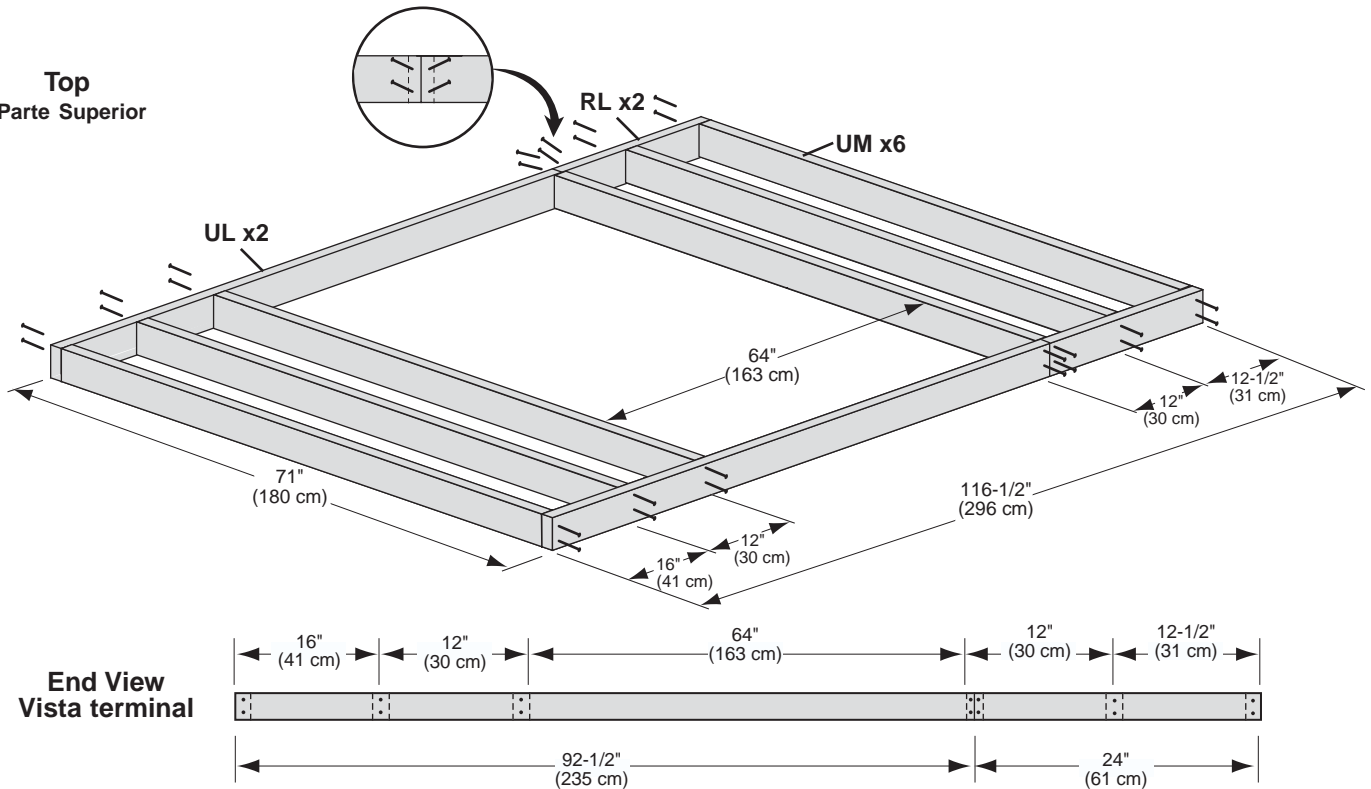

# WALL #10

2"(5 cm)

x 124

# MURO #10

See Page 8 For Building Tip!!!

¡Ver la página 8 para un consejo!!!

Top  
Parte Superior

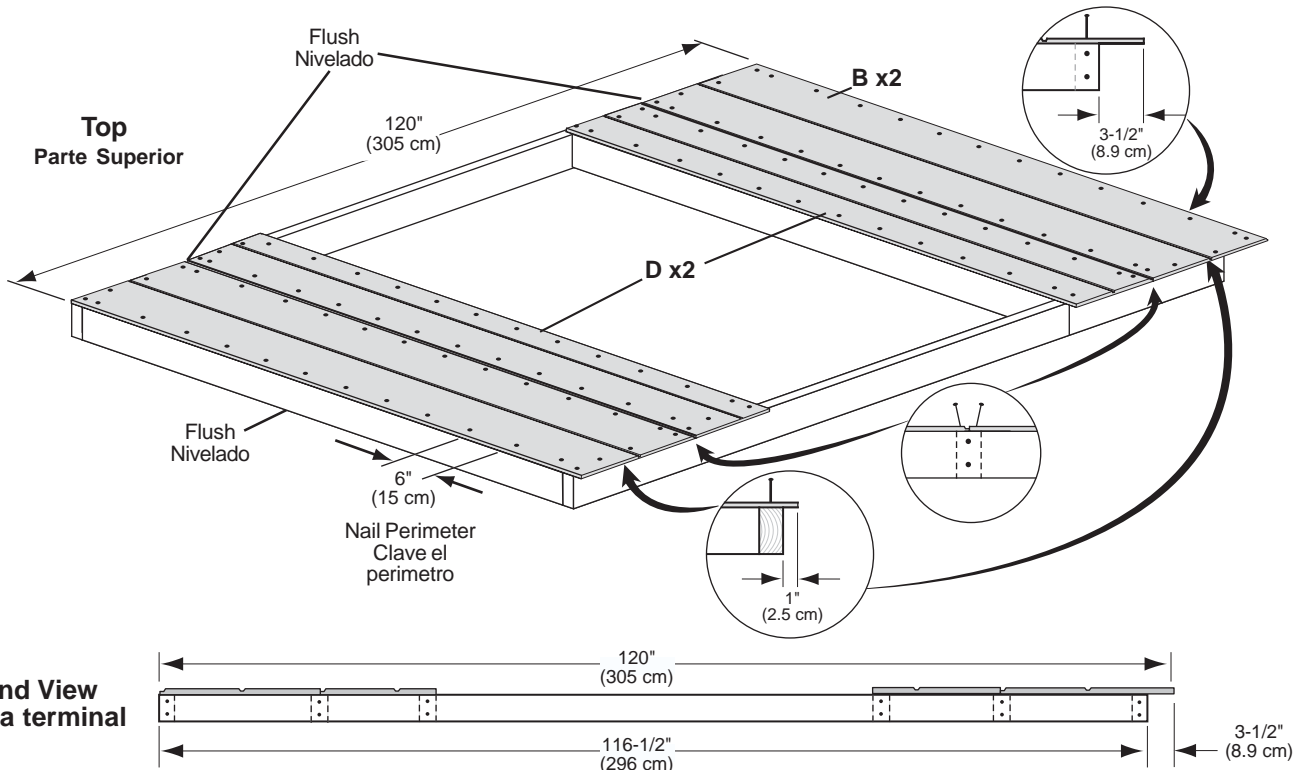

# WALL #11

3"(7.6 cm)

x 28

# MURO #11

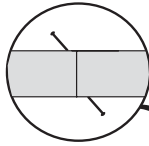

Top  
Parte Superior

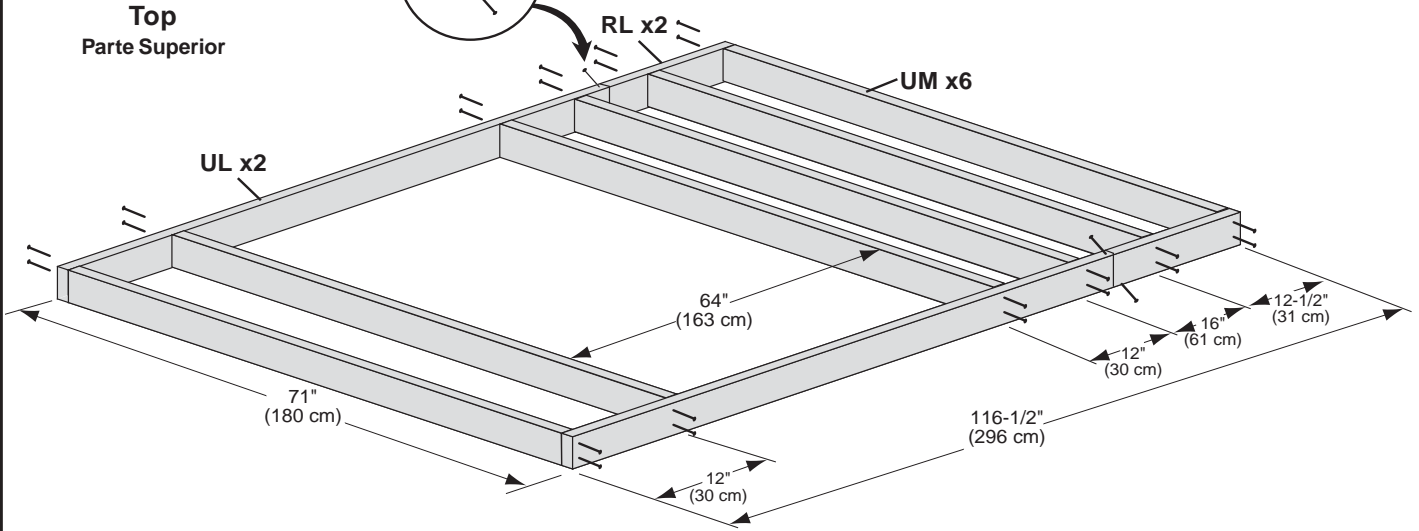

End View  
Vista terminal

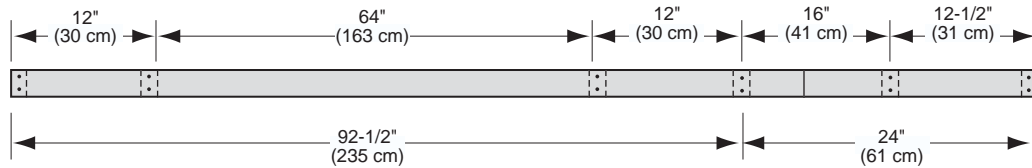

# WALL #11

2"(5 cm)

x 124

# MURO #11

See Page 8 For Building Tip!!!

¡Ver la página 8 para un consejo!!!

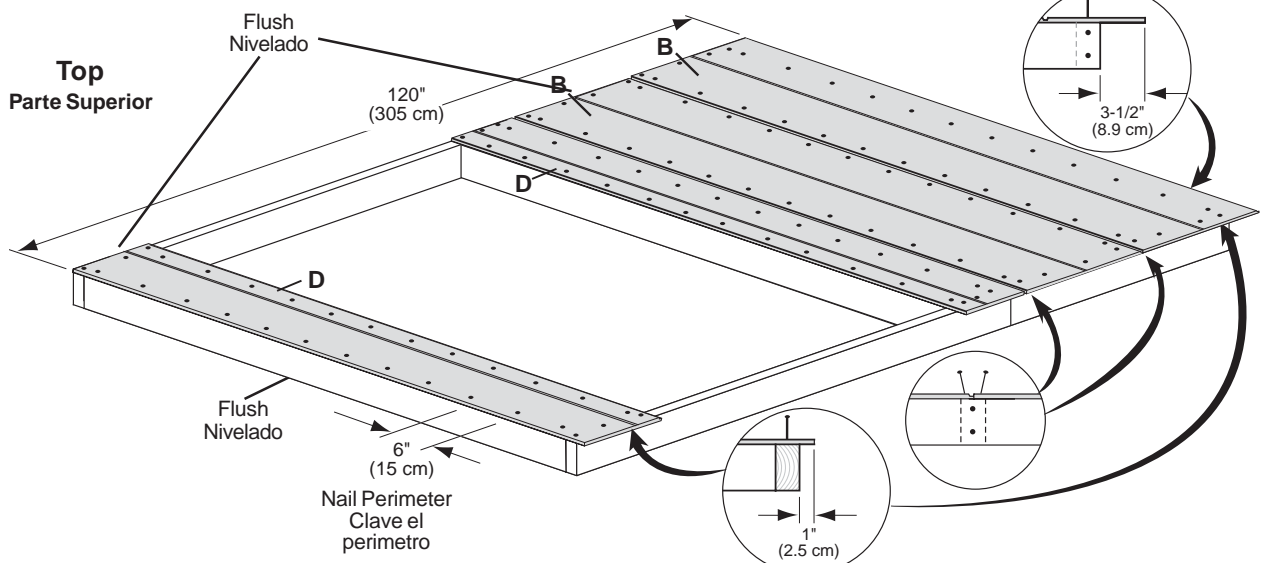

End View  
Vista terminal

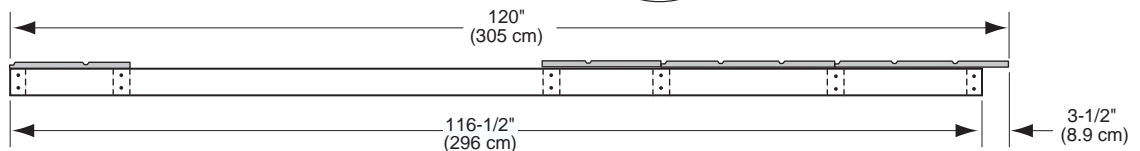

# WALL #12

3" (7.6 cm)

x 28

# MURO #12

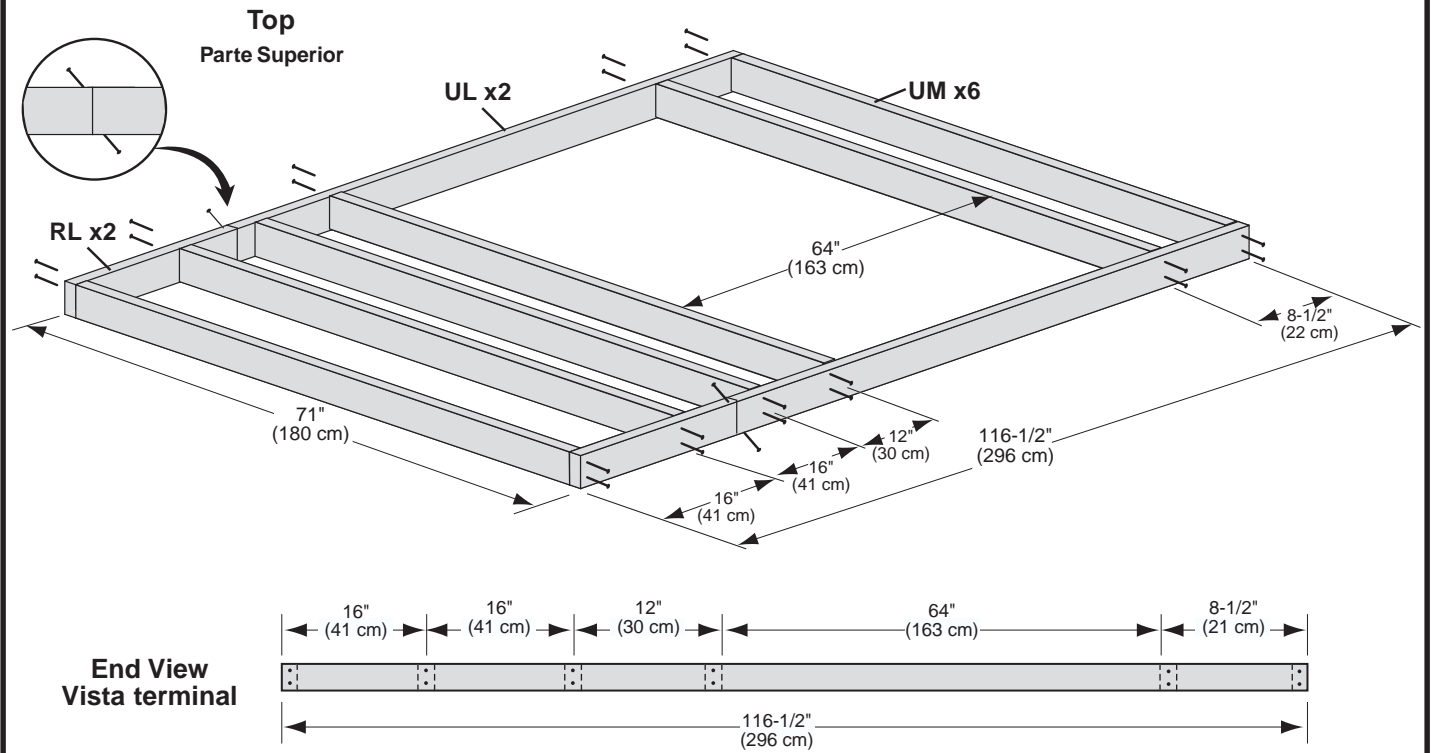

# WALL #12

2" (5 cm)

x 124

# MURO #12

See Page 8 For Building Tip!!!

¡Ver la página 8 para un consejo!!!

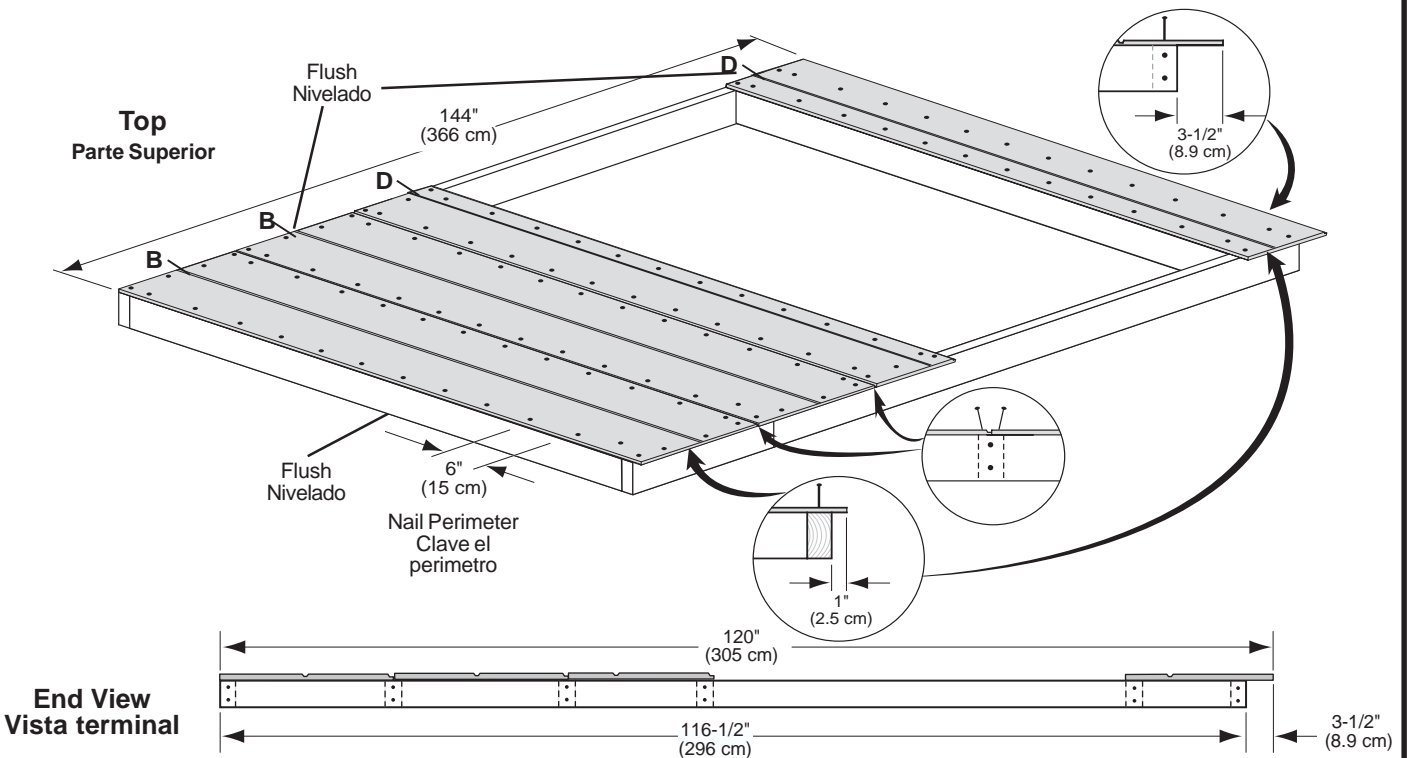

# WALL #13

3"(7.6 cm)

x 20

# MURO #13

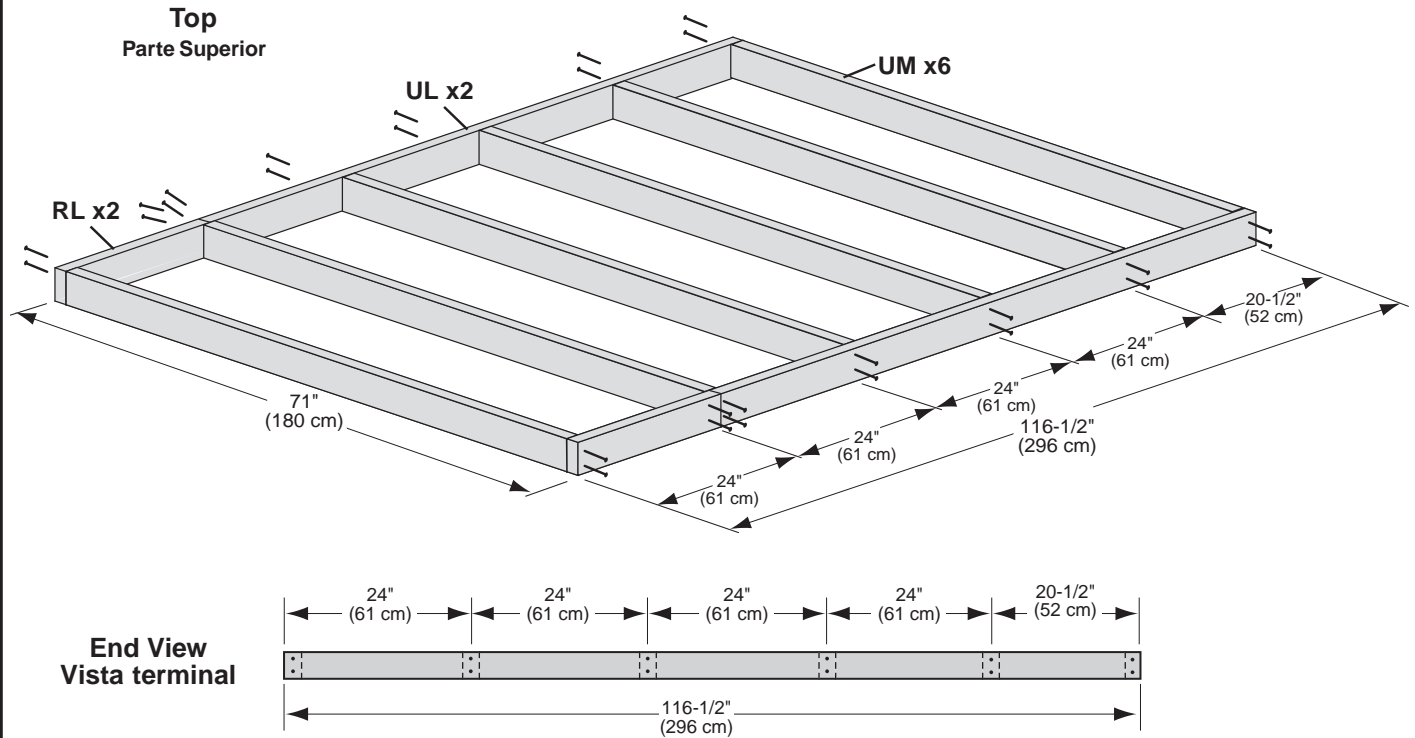

# WALL #13

2"(5 cm)

x 90

# MURO #13

See Page 8 For Building Tip!!!

¡Ver la página 8 para un consejo!!!

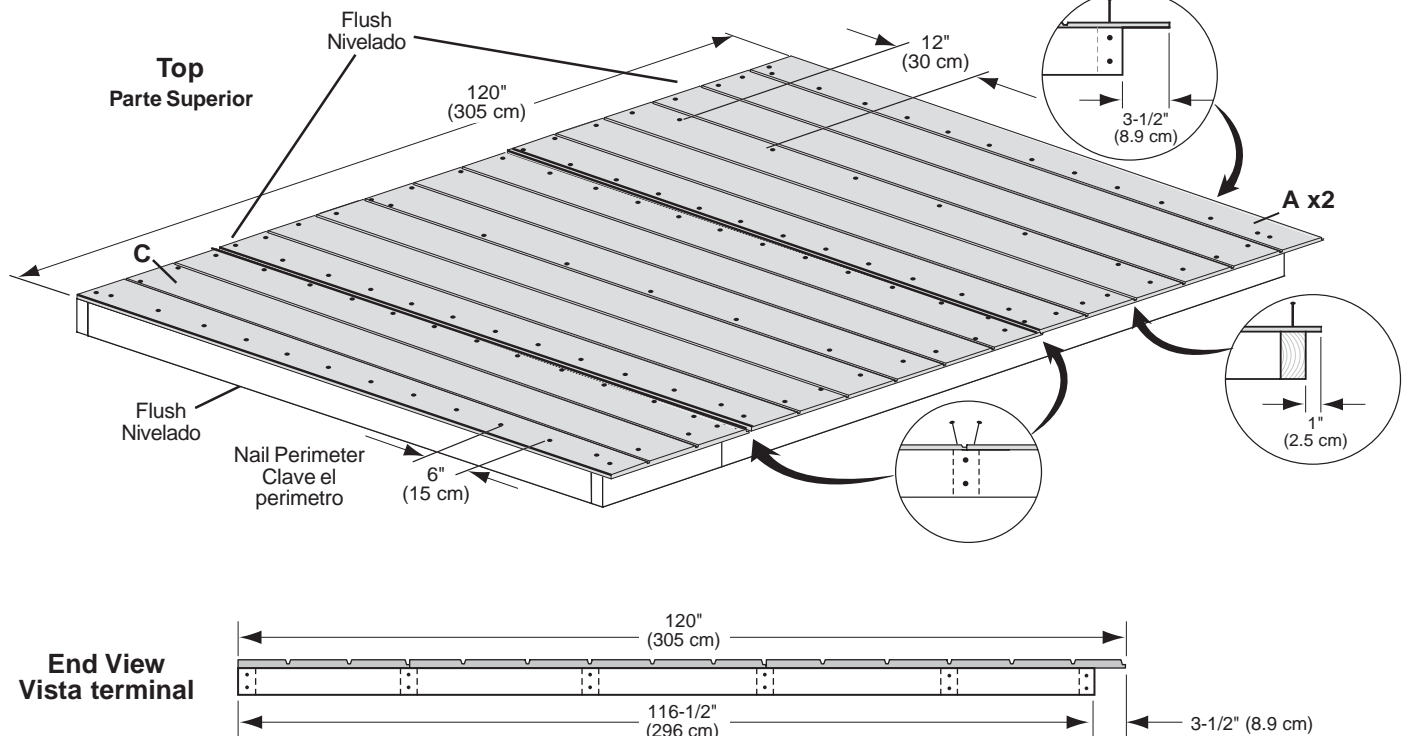

# WALL #14

3"(7.6 cm)

x 28

# MURO #14

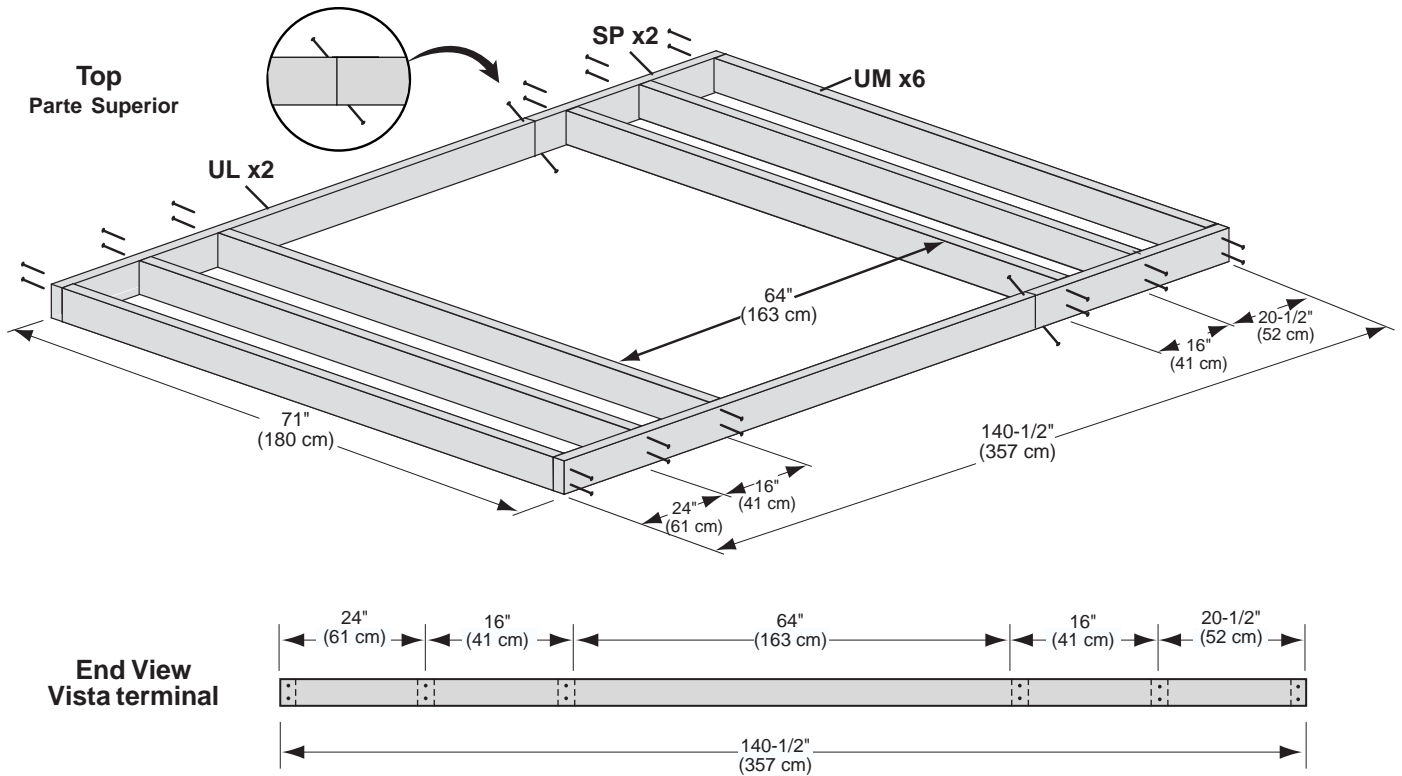

# WALL #14

2"(5 cm)

x 124

# MURO #14

See Page 8 For Building Tip!!!

¡Ver la página 8 para un consejo!!!

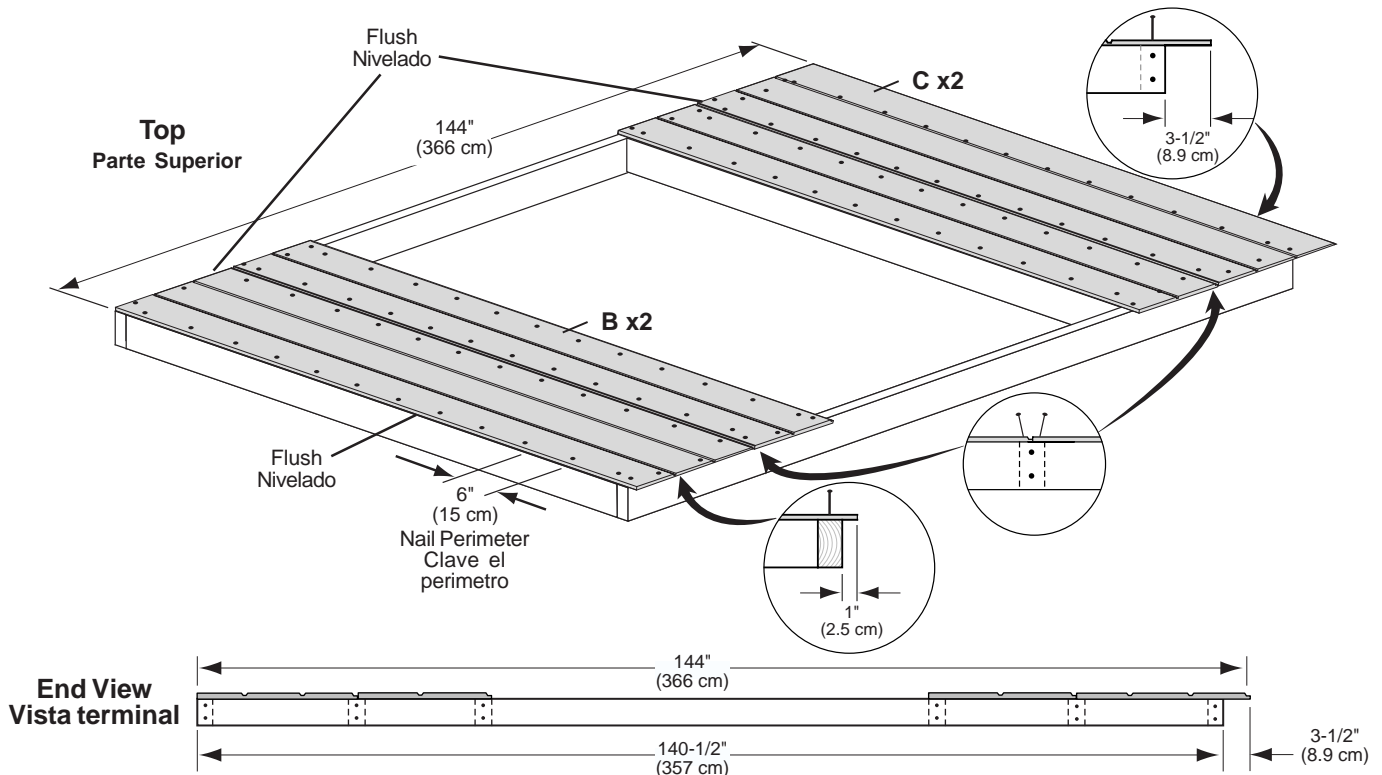



# WALL #15

3" (7.6 cm)

x 28

# MURO #15

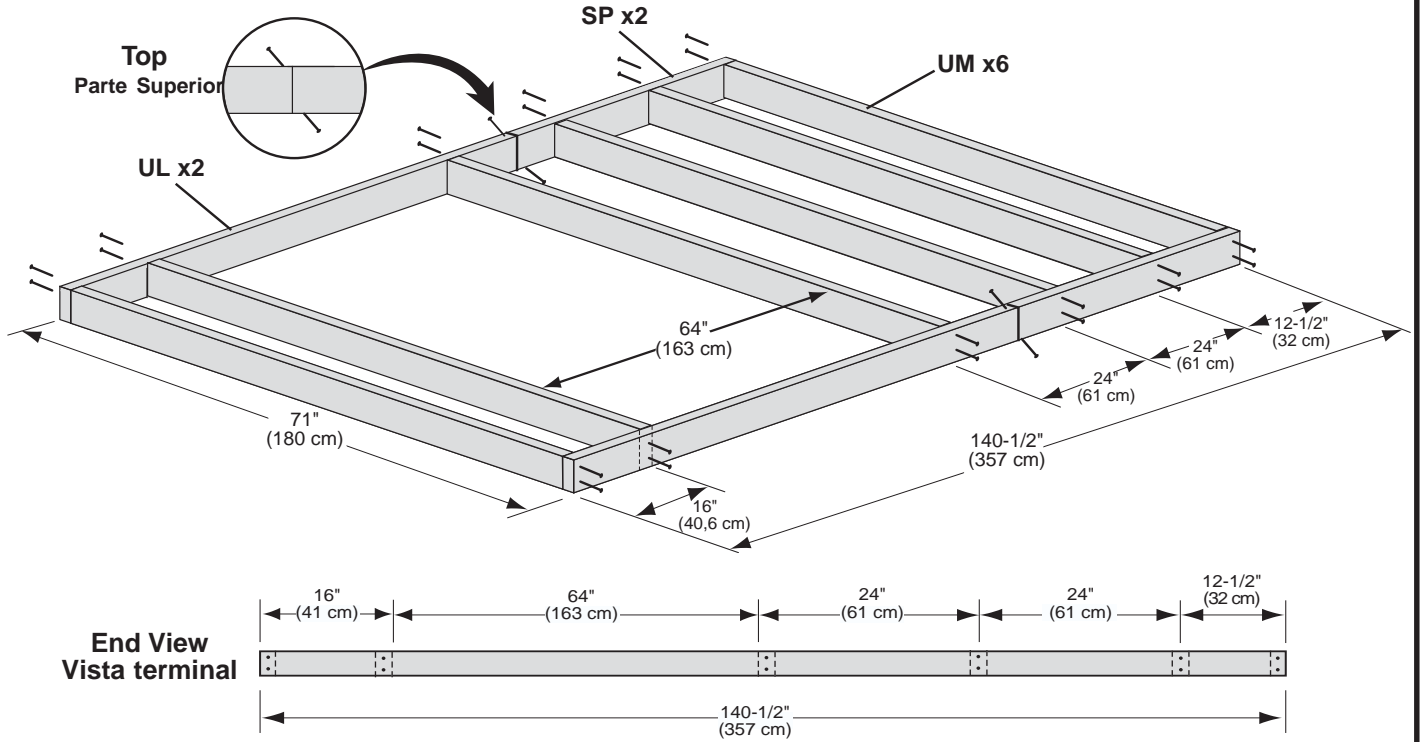

# WALL #15

2" (5 cm)

x 124

# MURO #15

See Page 8 For Building Tip!!!

¡Ver la página 8 para un consejo!!!

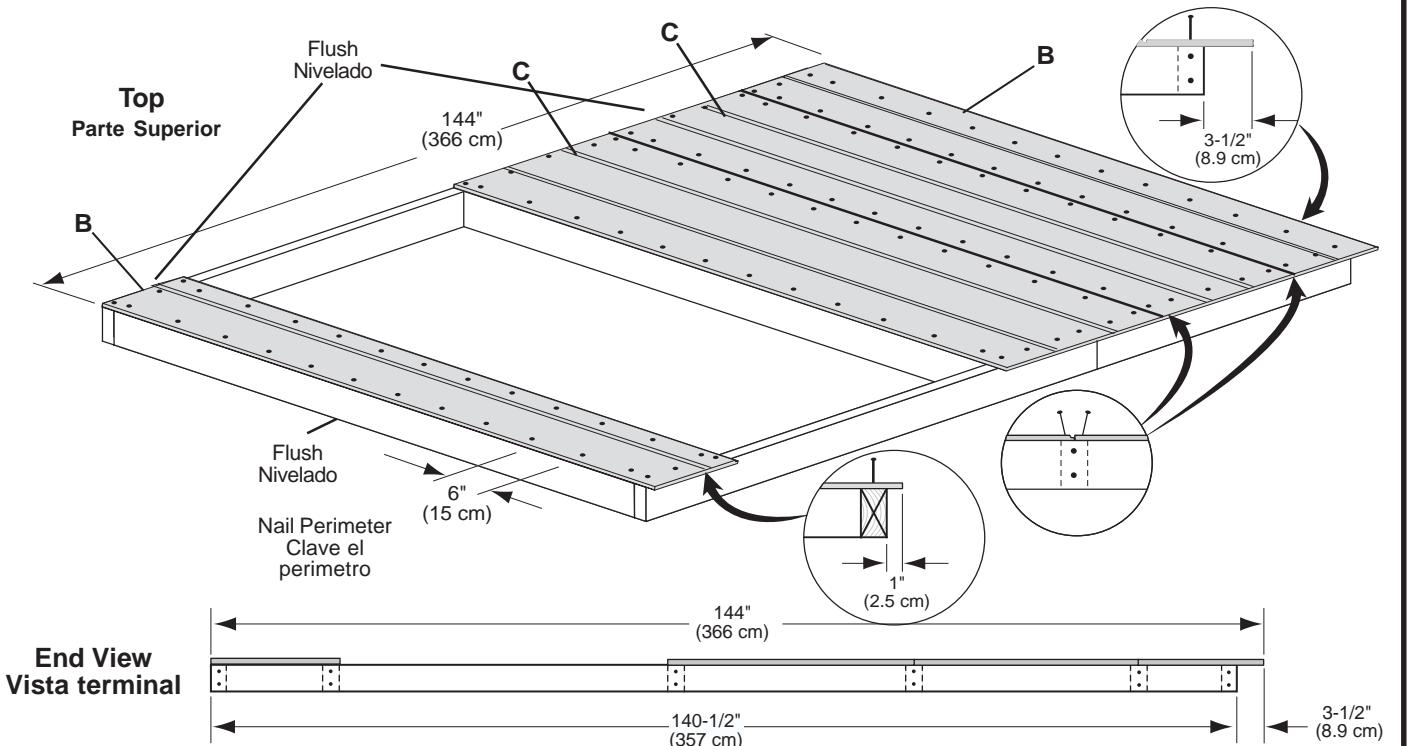

# WALL #16

3"(7.6 cm)

x 28

# MURO #16

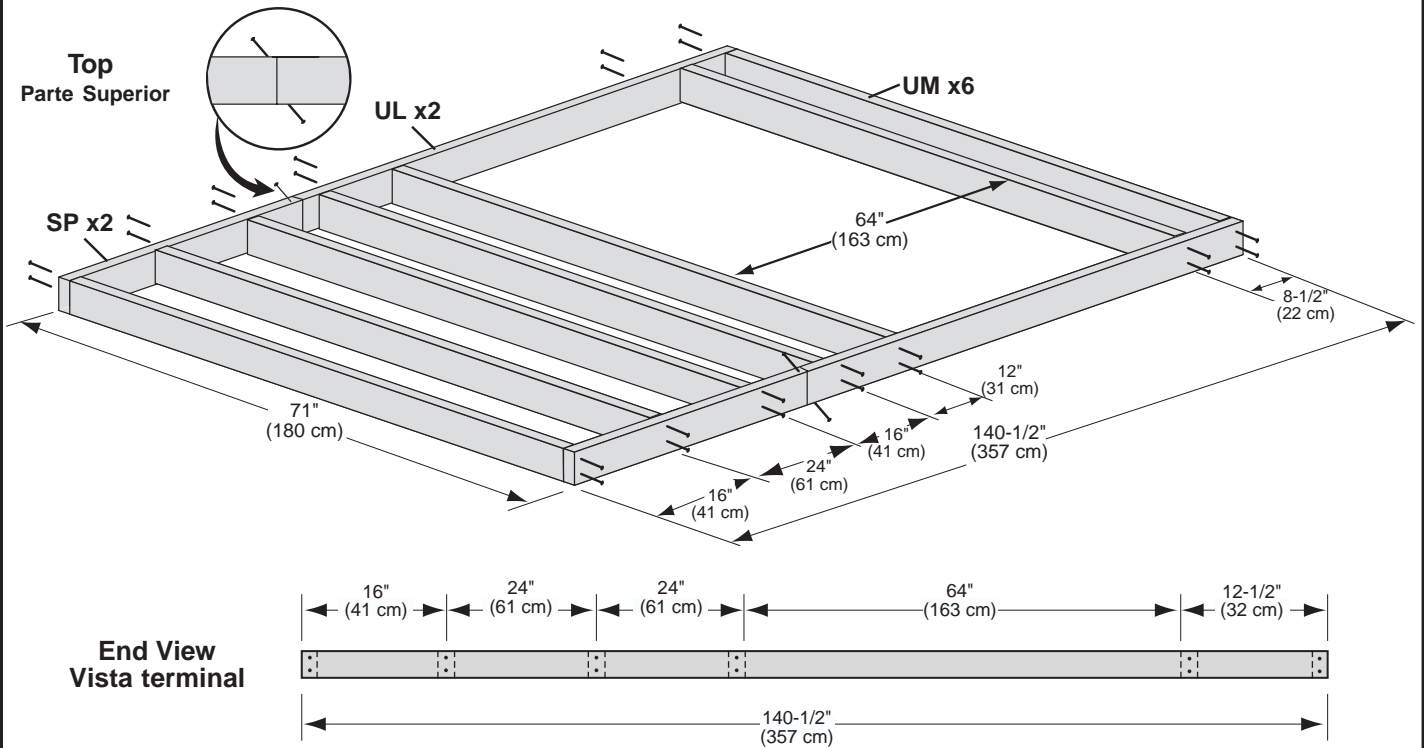

# WALL #16

2"(5 cm)

x 124

# MURO #16

See Page 8 For Building Tip!!!

¡Ver la página 8 para un consejo!!!

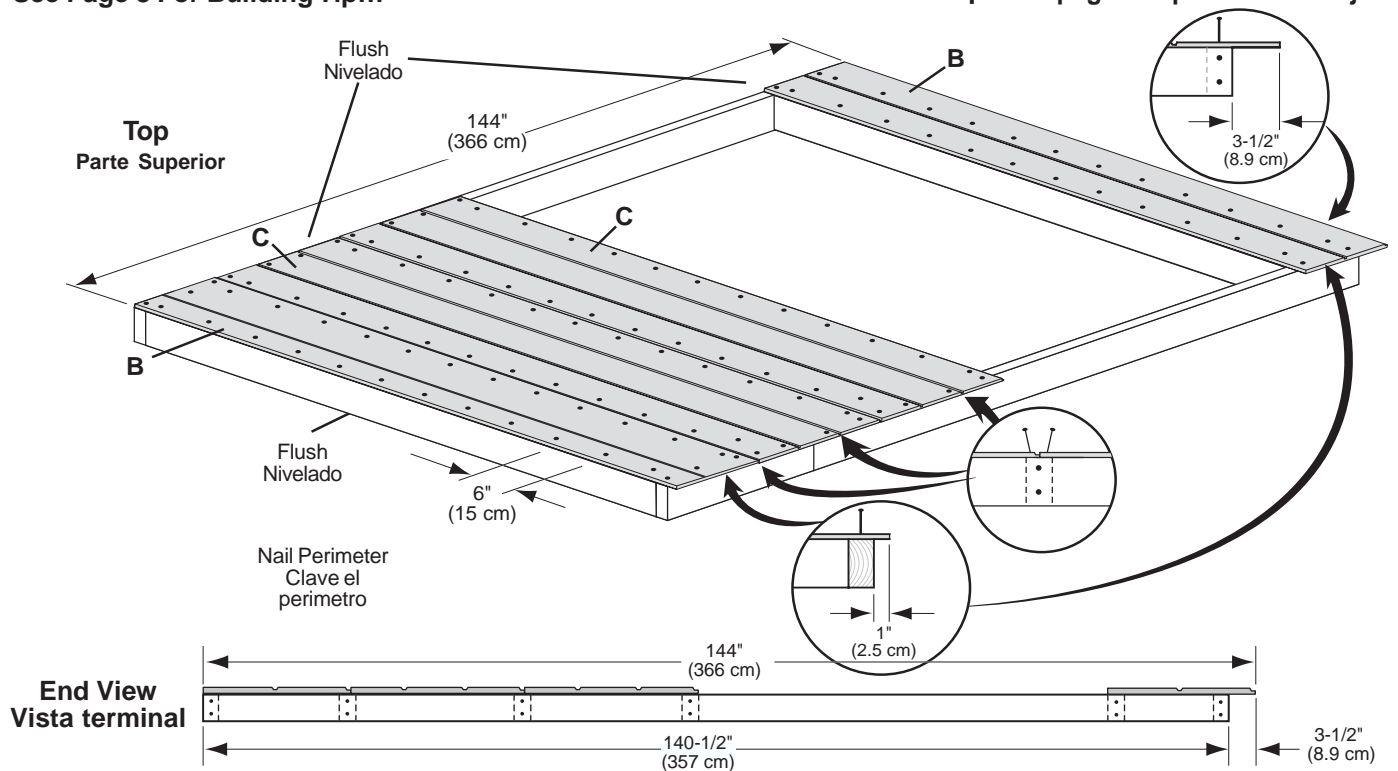

# WALL #17

3"(7.6 cm)

x 32

# MURO #17

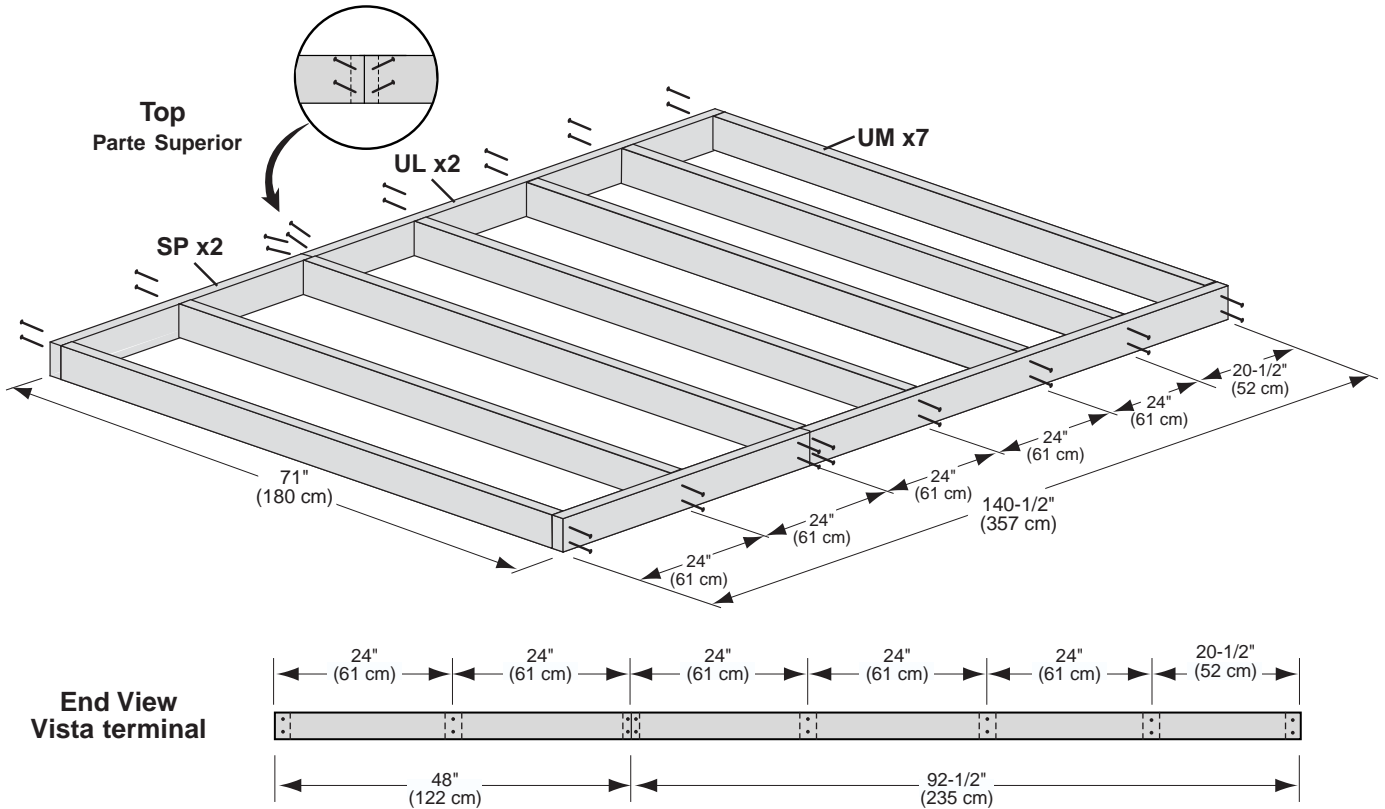

# WALL #17

2"(5 cm)

x 135

# MURO #17

See Page 8 For Building Tip!!!

¡Ver la página 8 para un consejo!!!

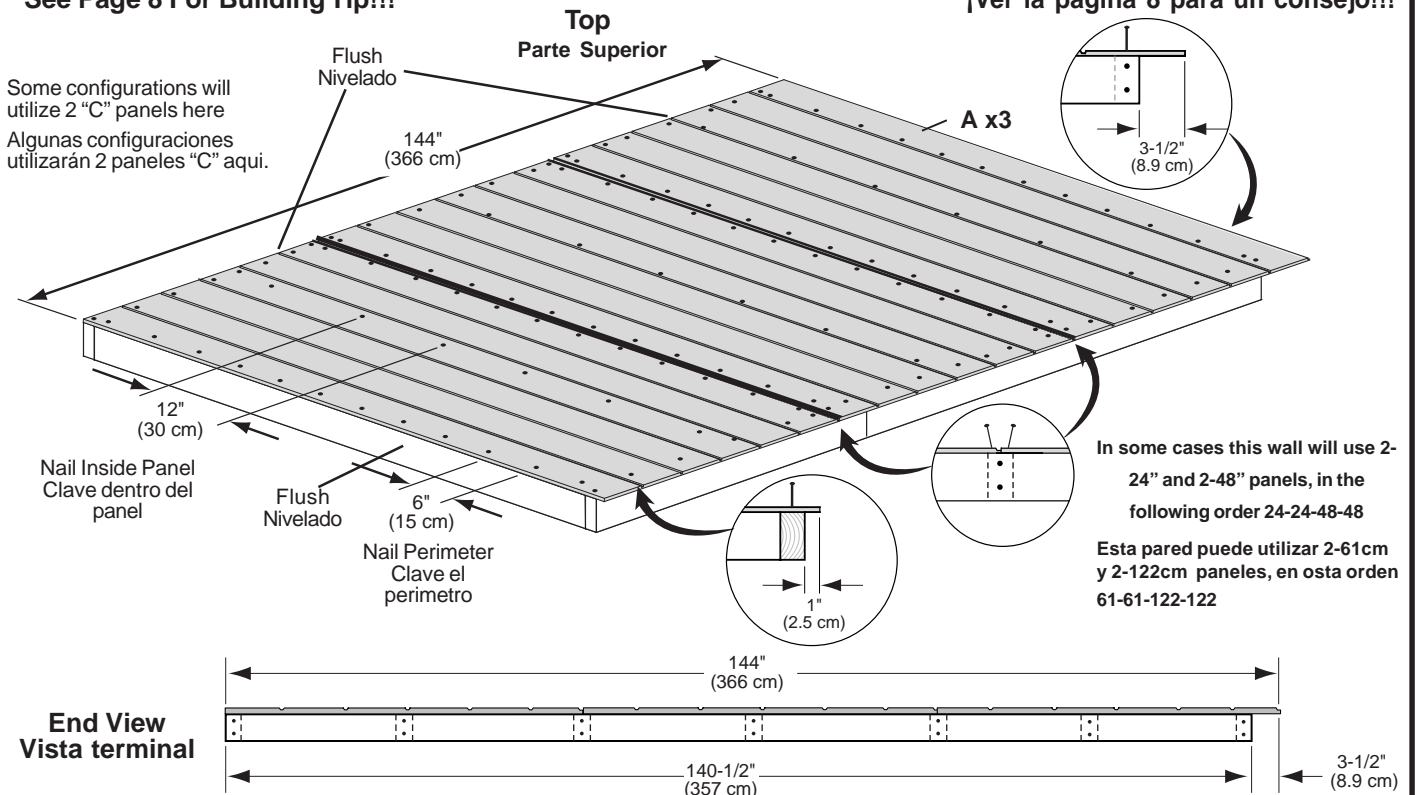

# WALL #18

3"(7.6 cm)

x 40

# MURO #18

Top  
Parte Superior

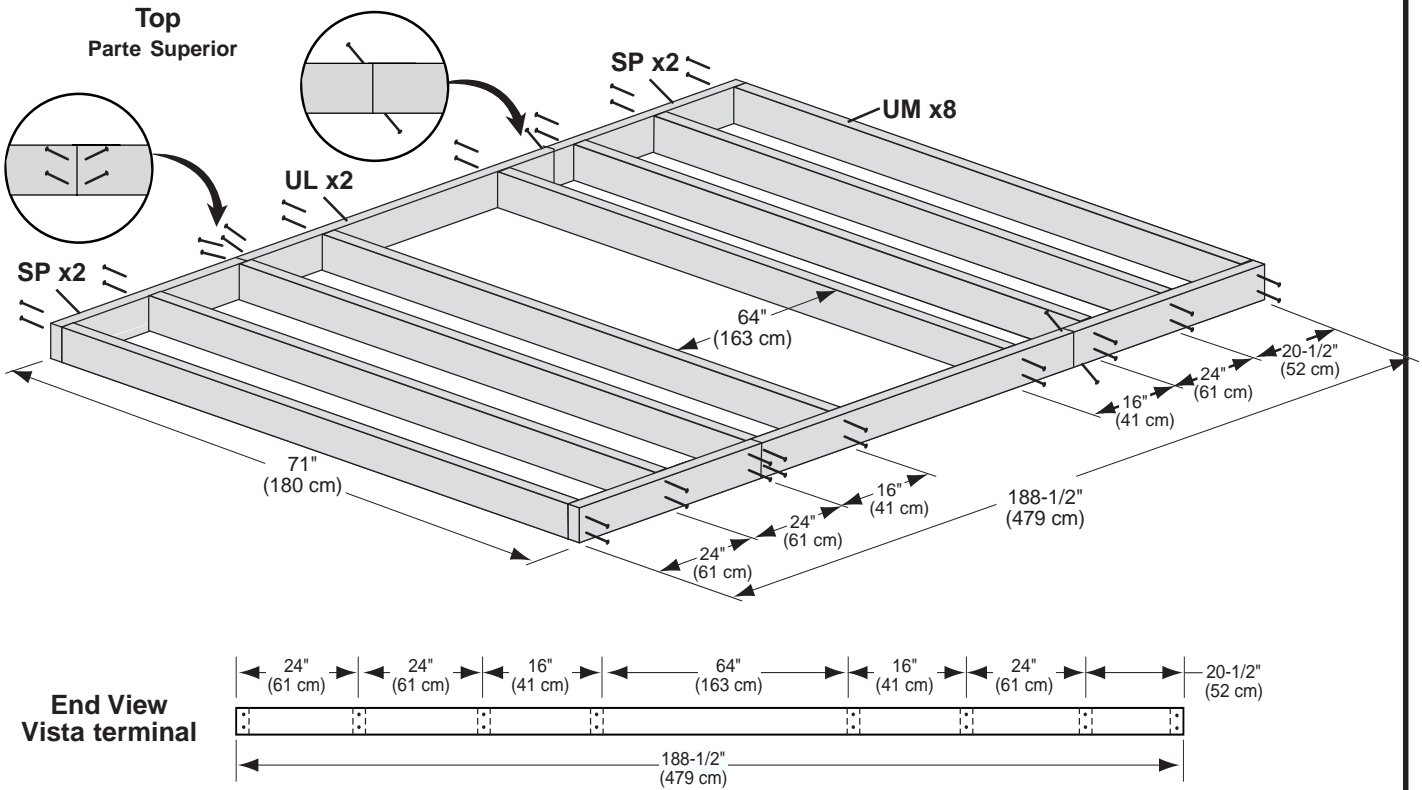

# WALL #18

2"(5 cm)

x 188

# MURO #18

See Page 8 For Building Tip!!!

¡Ver la página 8 para un consejo!!!

Top  
Parte Superior

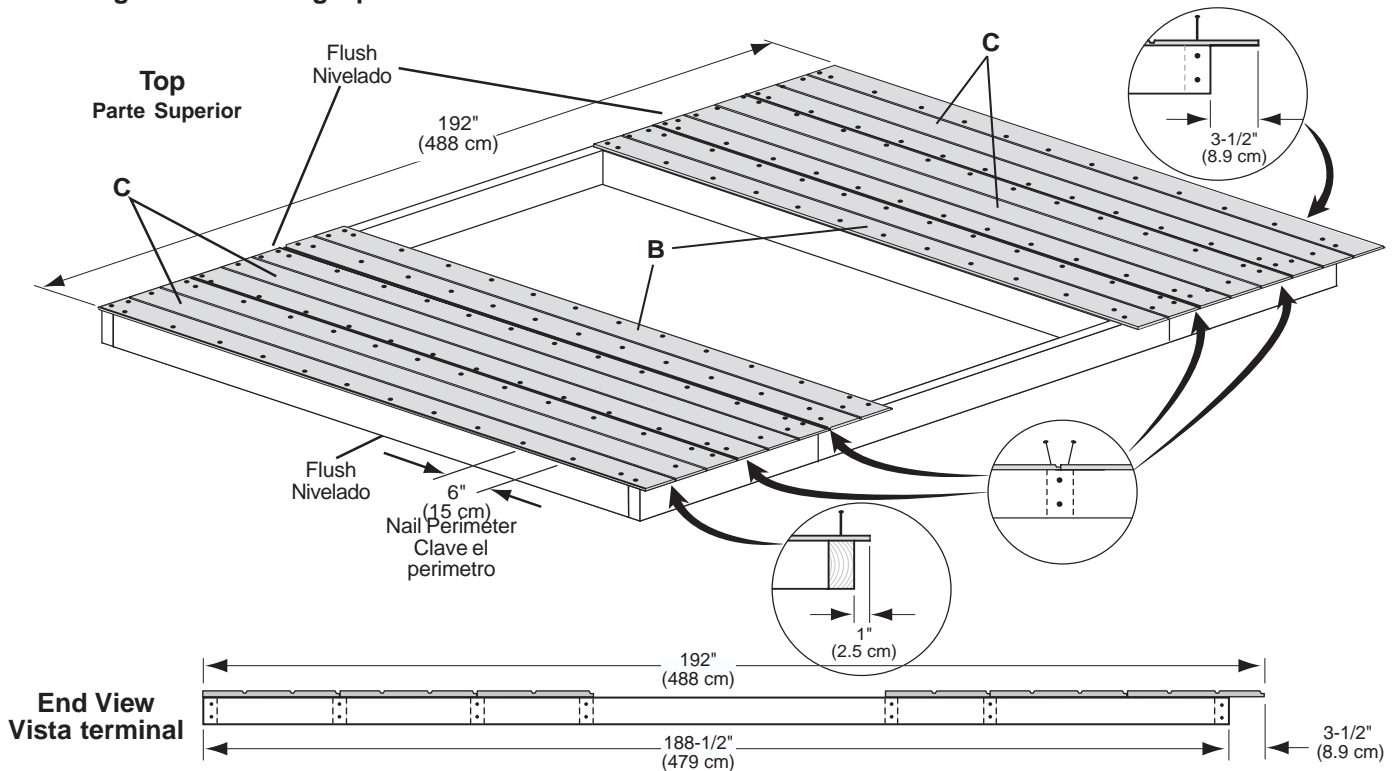

# WALL #19

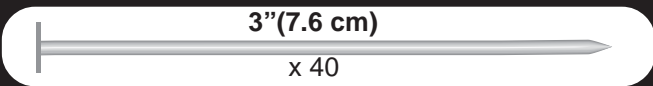

# MURO #19

Top  
Parte Superior

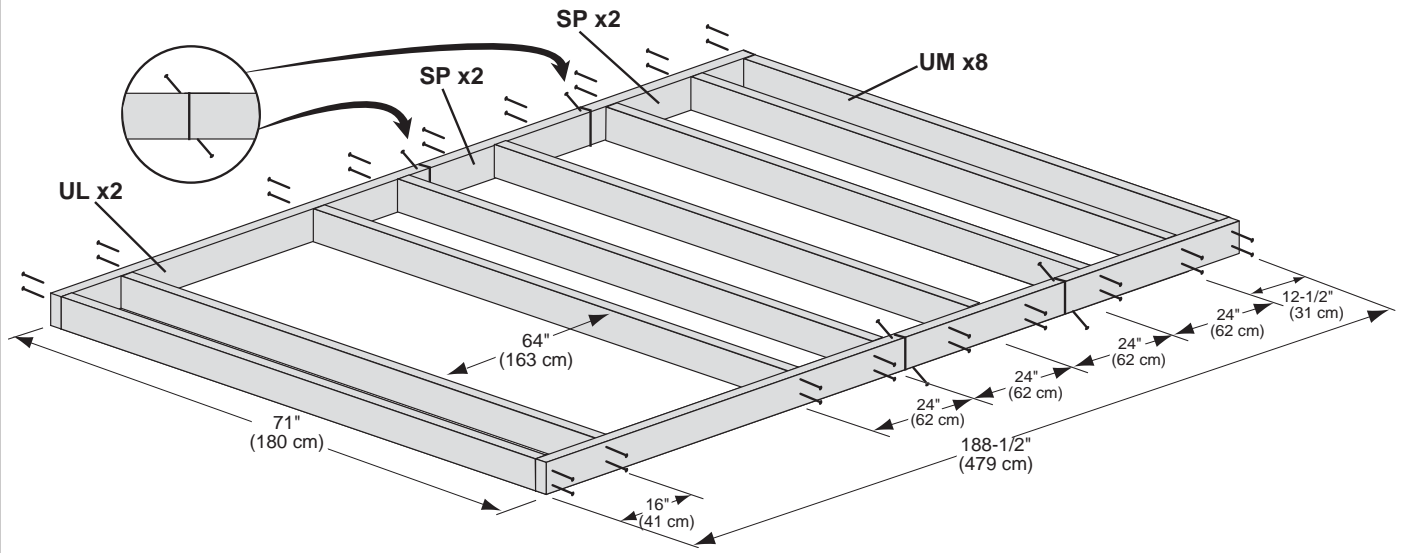

End View  
Vista terminal

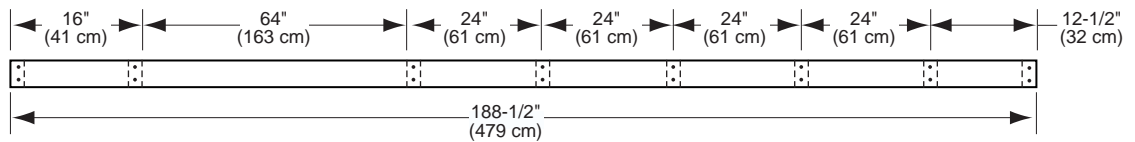

# WALL #19

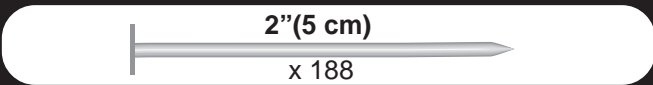

# MURO #19

See Page 8 For Building Tip!!!

¡Ver la página 8 para un consejo!!!

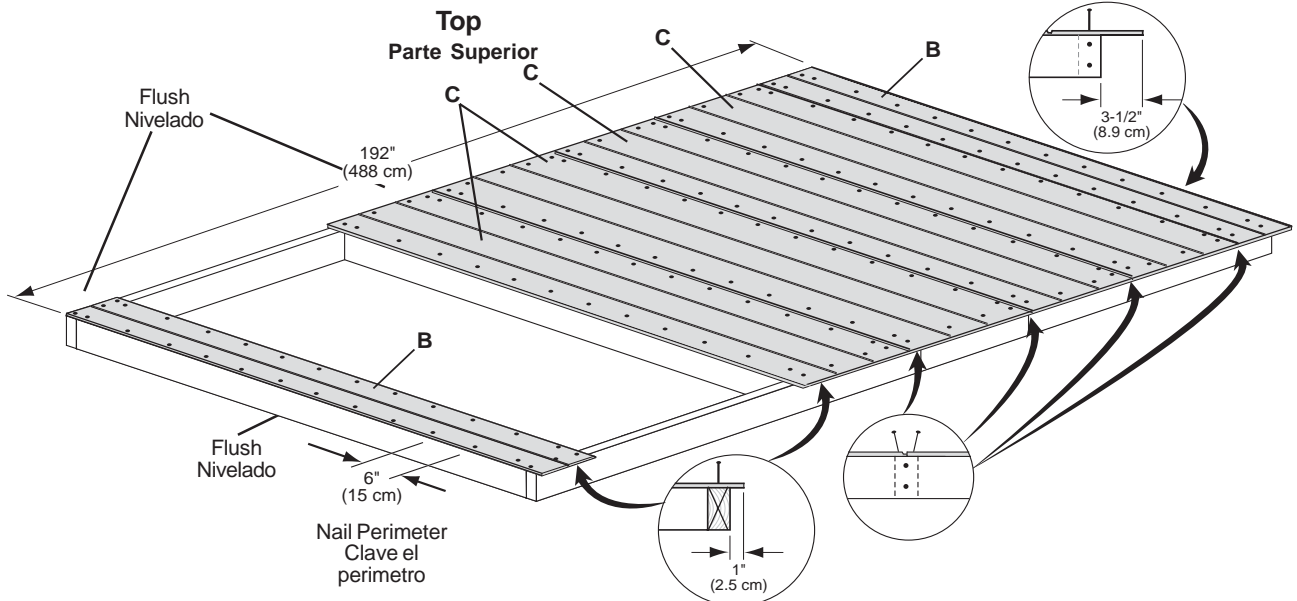

End View  
Vista terminal

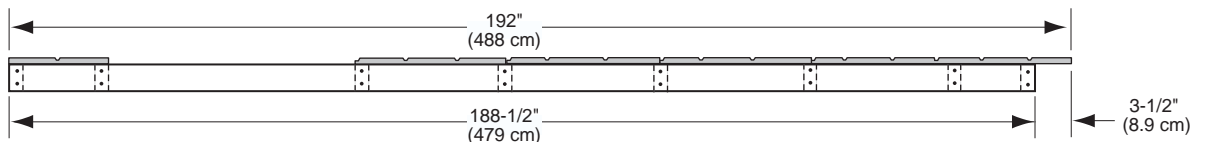

WALL #20

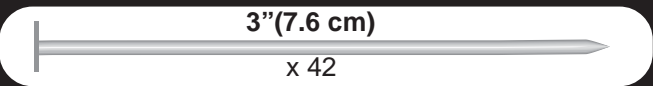

MURO #20

Top  
Parte Superior

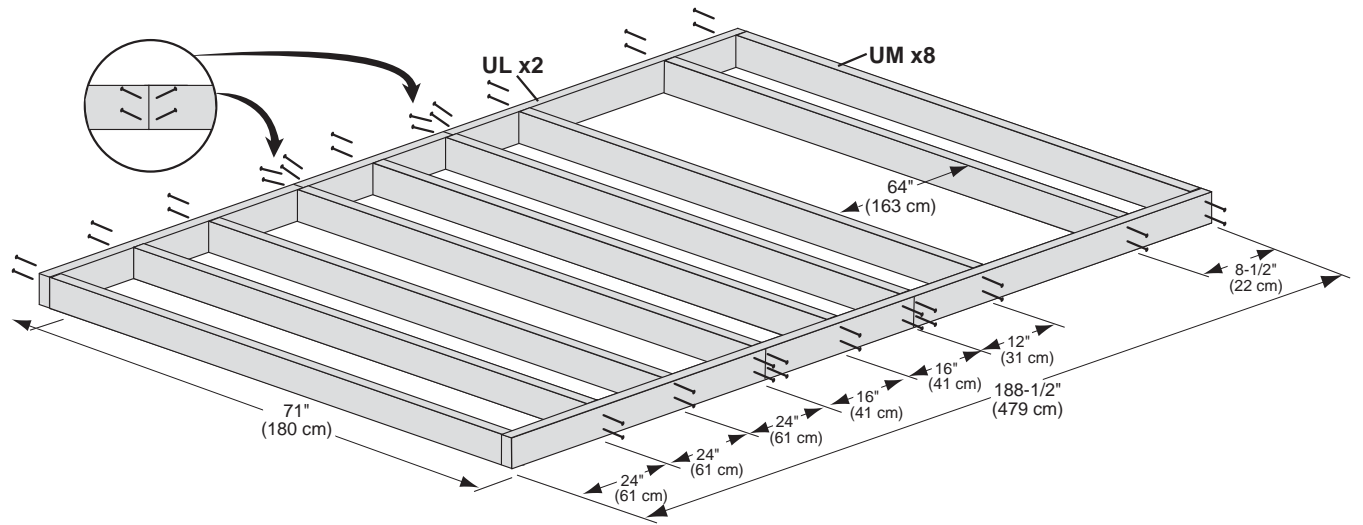

End View  
Vista terminal

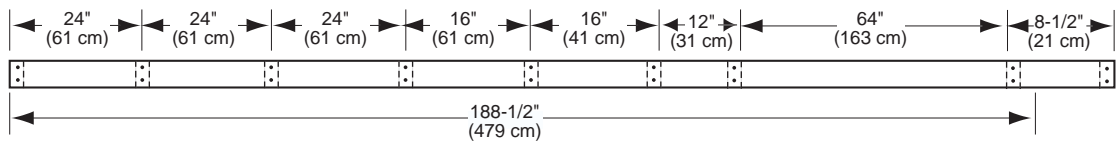

WALL #20

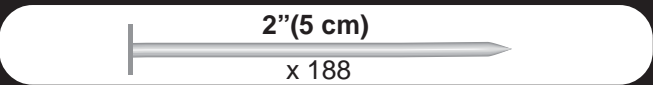

MURO #20

See Page 8 For Building Tip!!!

¡Ver la página 8 para un consejo!!!

Top  
Parte Superior

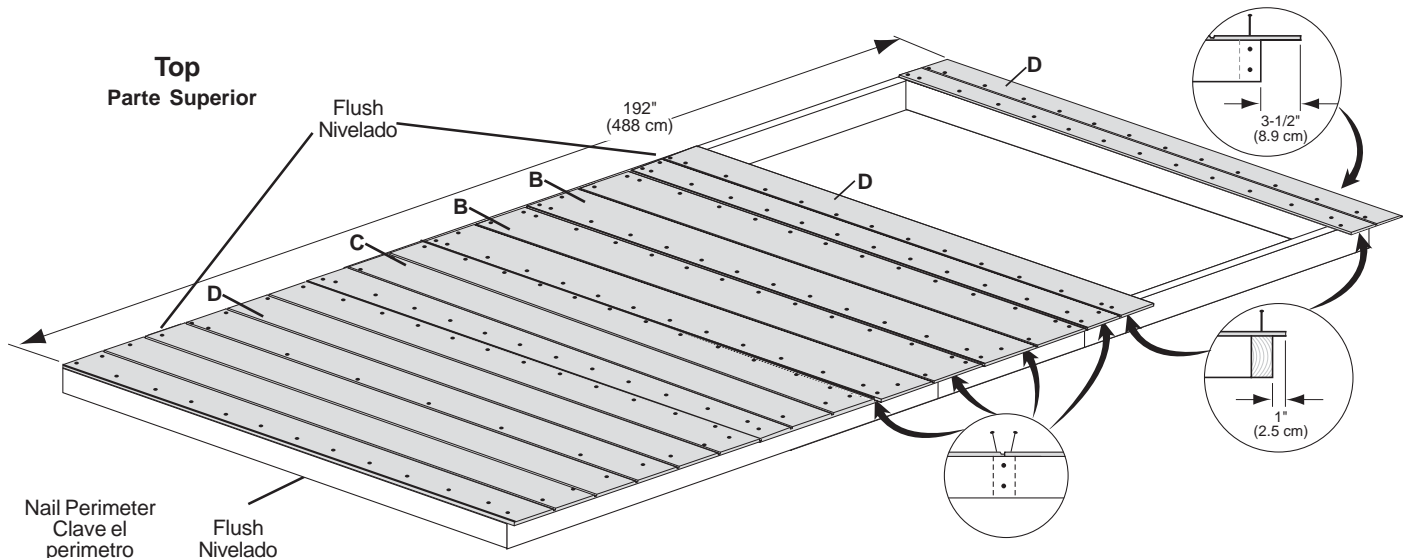

End View  
Vista terminal

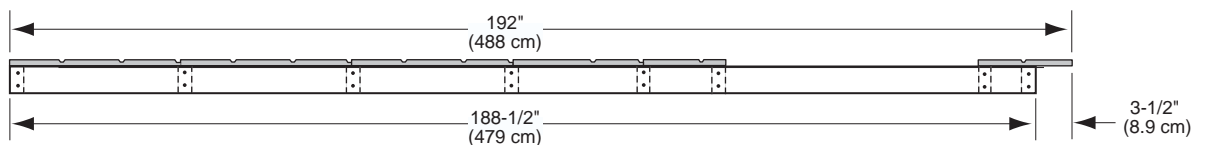

# WALL #21

3"(7.6 cm)

x 44

# MURO #21

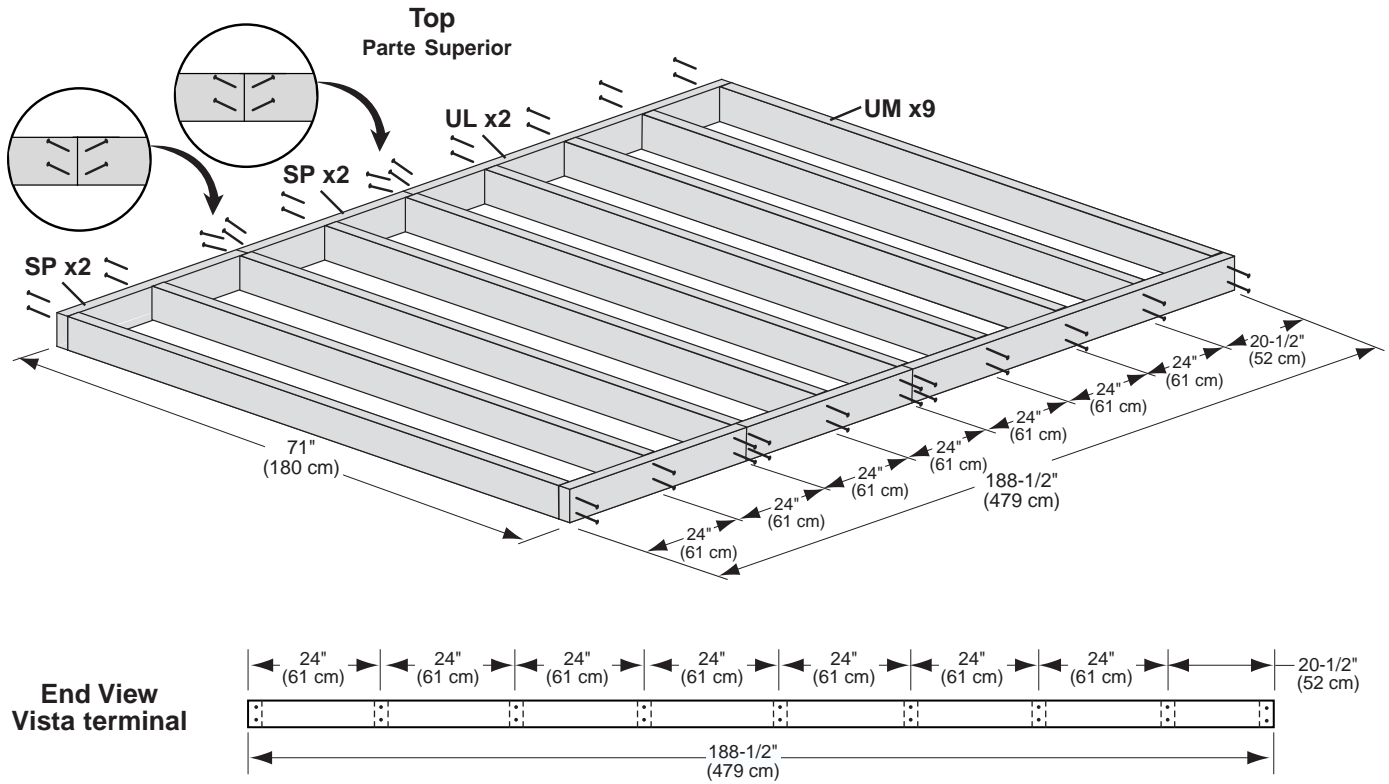

# WALL #21

2"(5 cm)

x 180

# MURO #21

See Page 8 For Building Tip!!!

¡Ver la página 8 para un consejo!!!

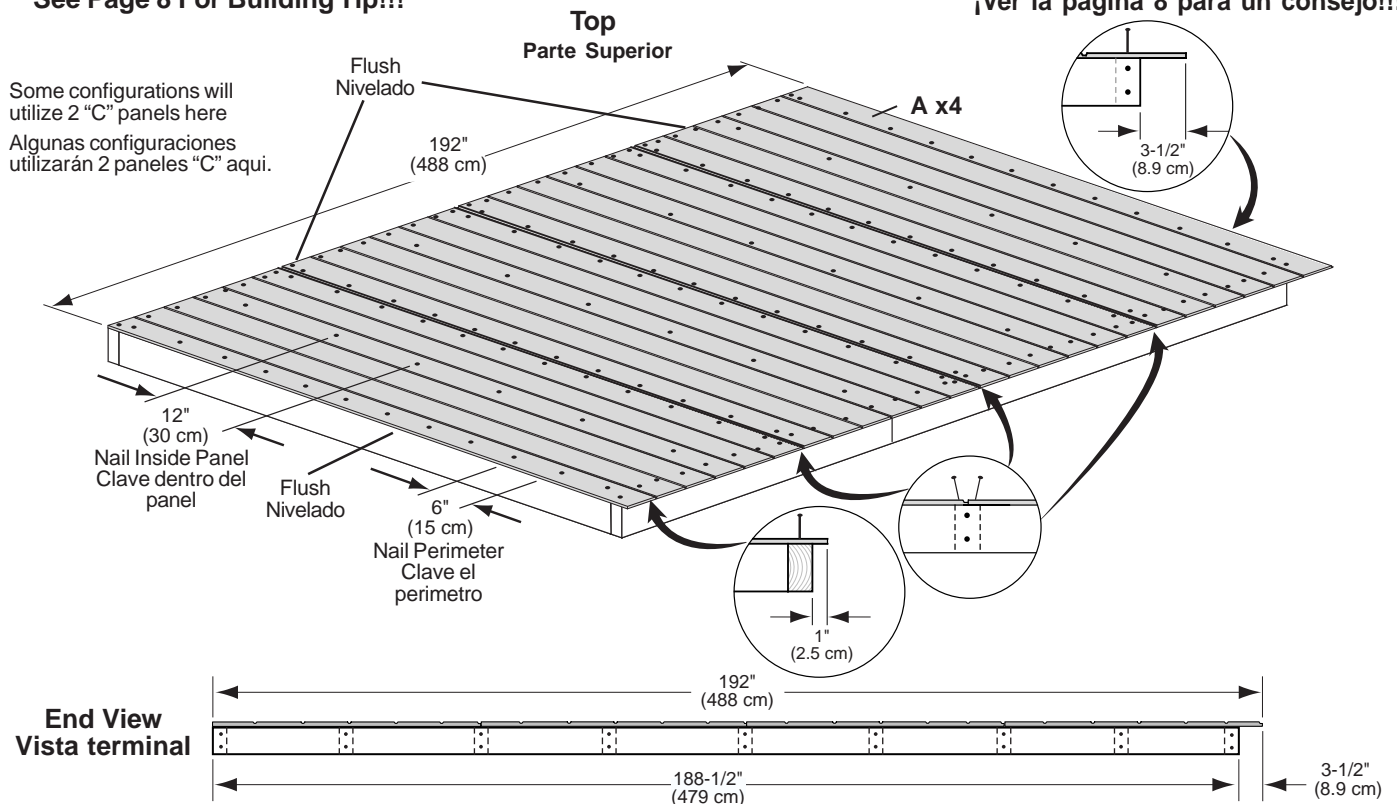

# WALL #22

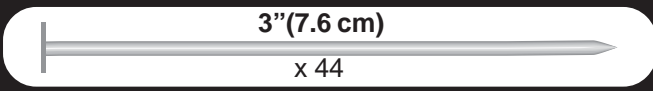

# MURO #22

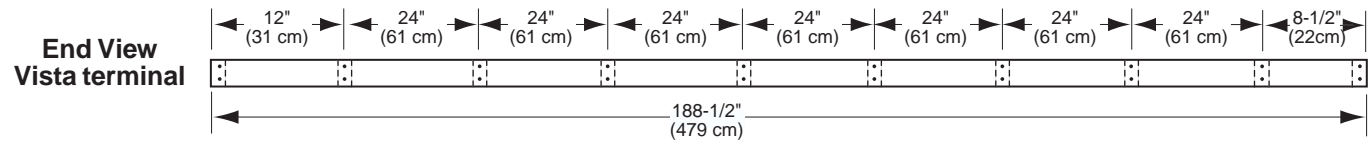
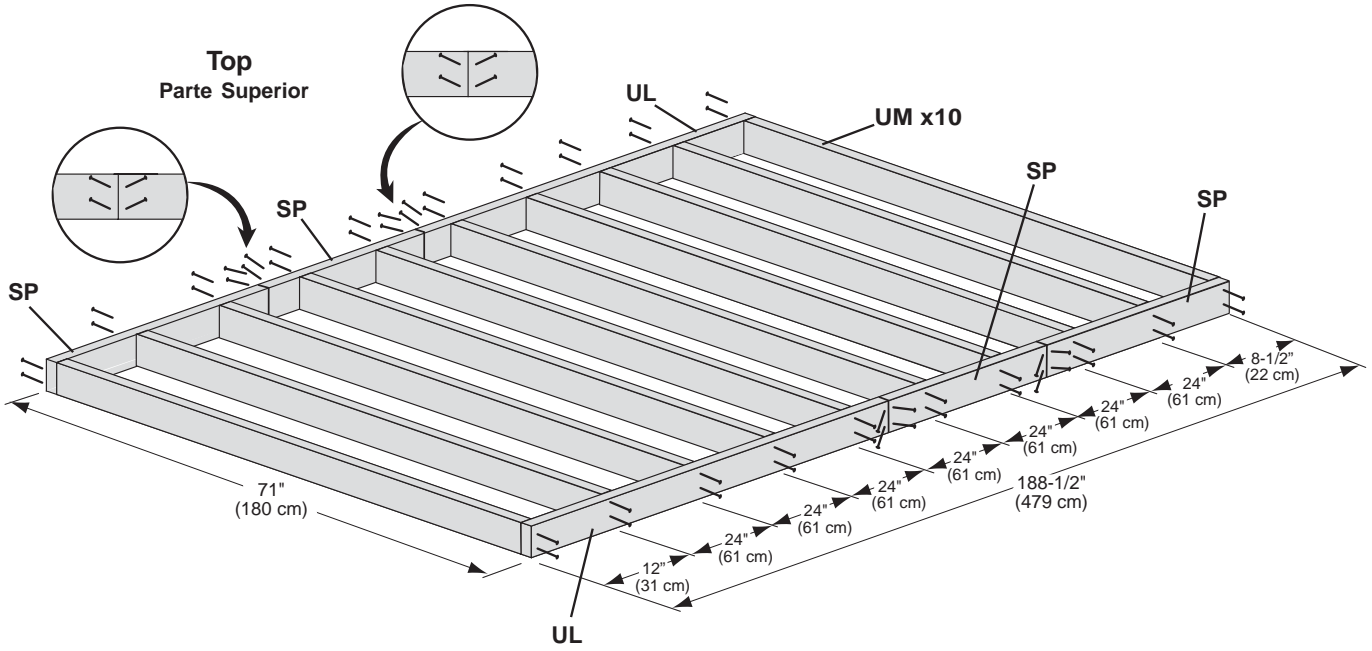

# WALL #22

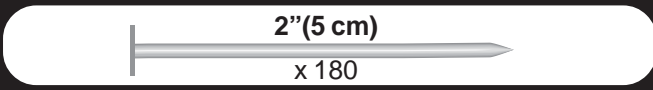

# MURO #22

See Page 8 For Building Tip!!!

¡Ver la página 8 para un consejo!!!

Some configurations will utilize 2 "C" panels here  
Algunas configuraciones utilizarán 2 paneles "C" aquí.

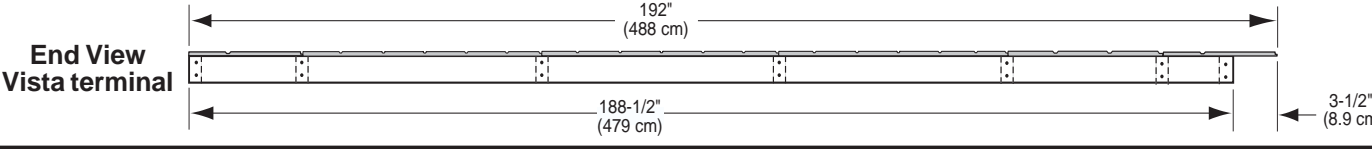
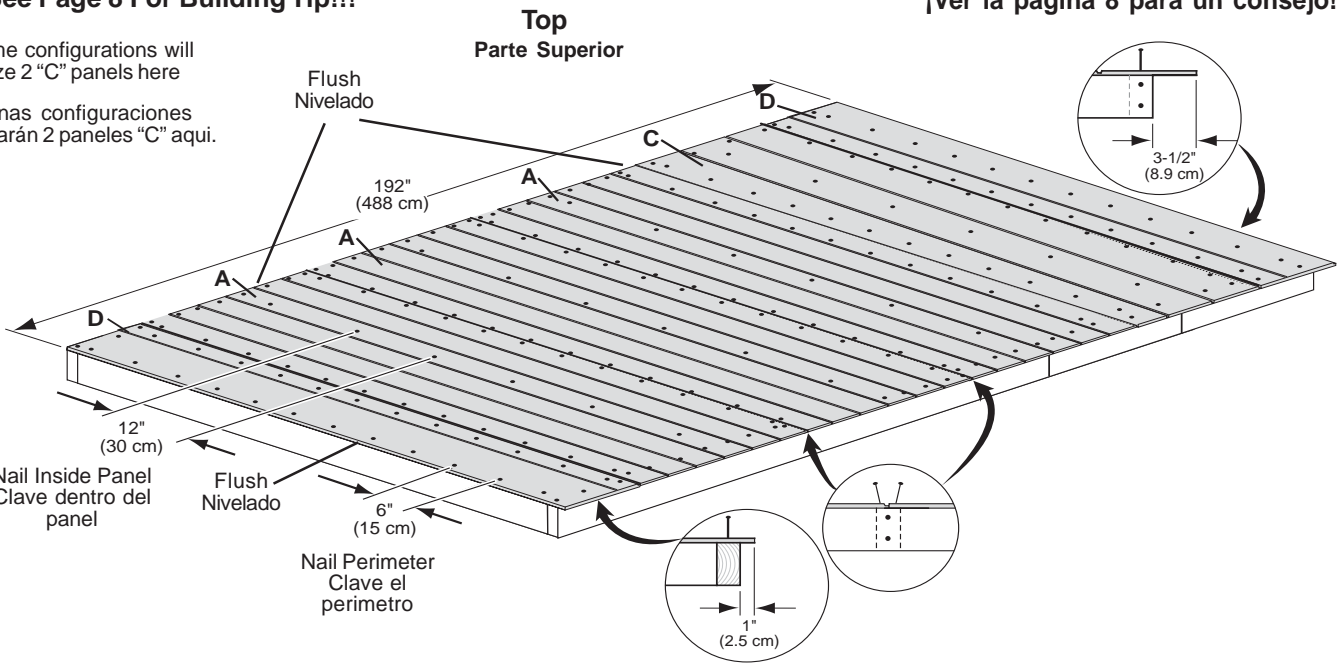



# ERECTING WALLS

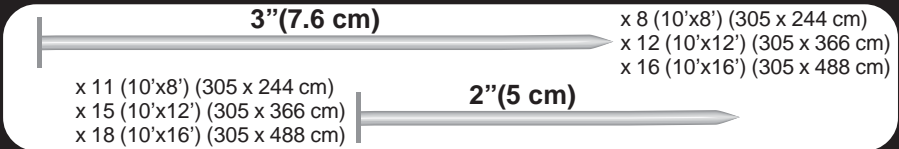

# CONSTRUYENDO LOS MUROS

See Page 7 For Building Tip!!!

¡Ver la página 7 para un consejo!!!

**ERECT SOLID WALLS FIRST**  
**CONSTRUYA LOS MUROS SÓLIDOS PRIMERO**

See Page 6 for wall #  
 Ver la página 6 para # muro.

Level Wall and Brace, Do not sink nails completely  
 Nivela la pared y refuérzala. No hínque los clavos completamente.

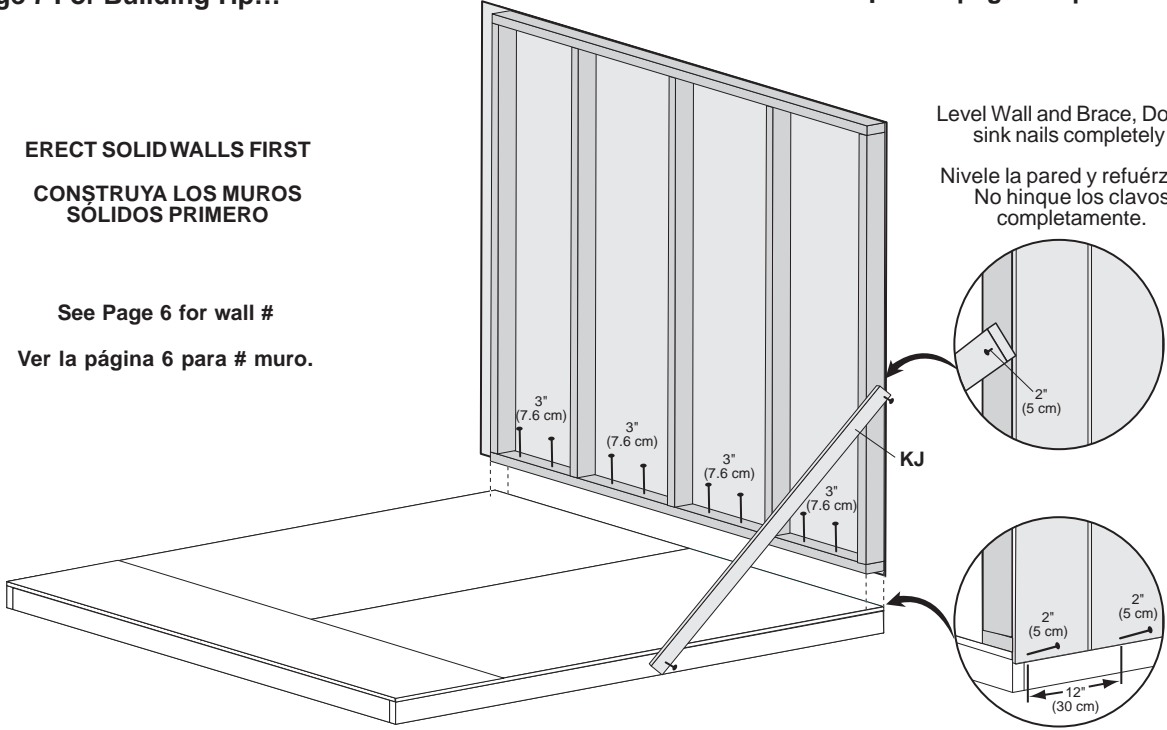

# ERECTING WALLS



# CONSTRUYENDO LOS MUROS

See Page 7 For Building Tip!!!

¡Ver la página 7 para un consejo!!!

See Page 6 for wall #  
 Ver la página 6 para # muro.

Level Wall and Nail  
 Nivela la pared y clave.

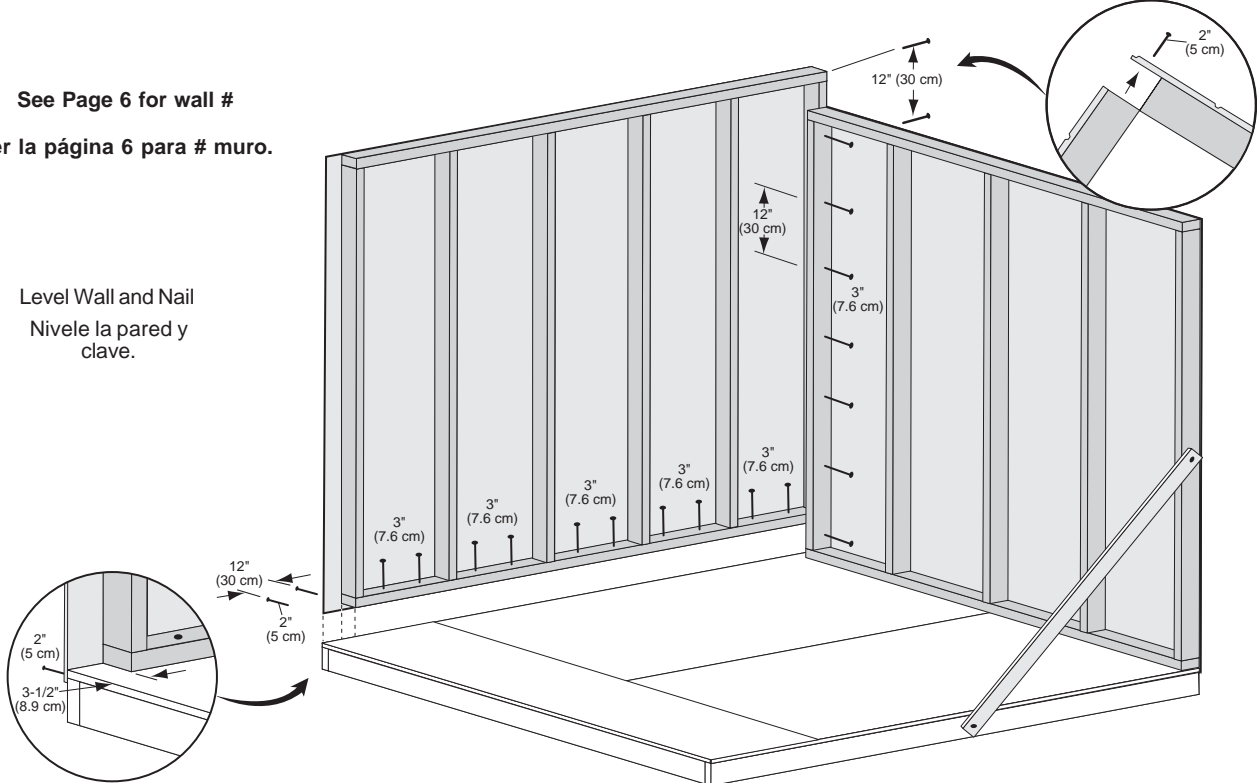

# ERECTING WALLS

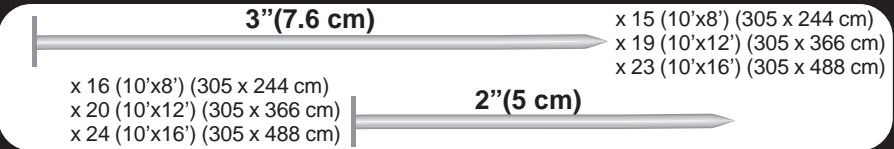

# CONSTRUYENDO LOS MUROS

See Page 7 For Building Tip!!!

¡Ver la página 7 para un consejo!!!

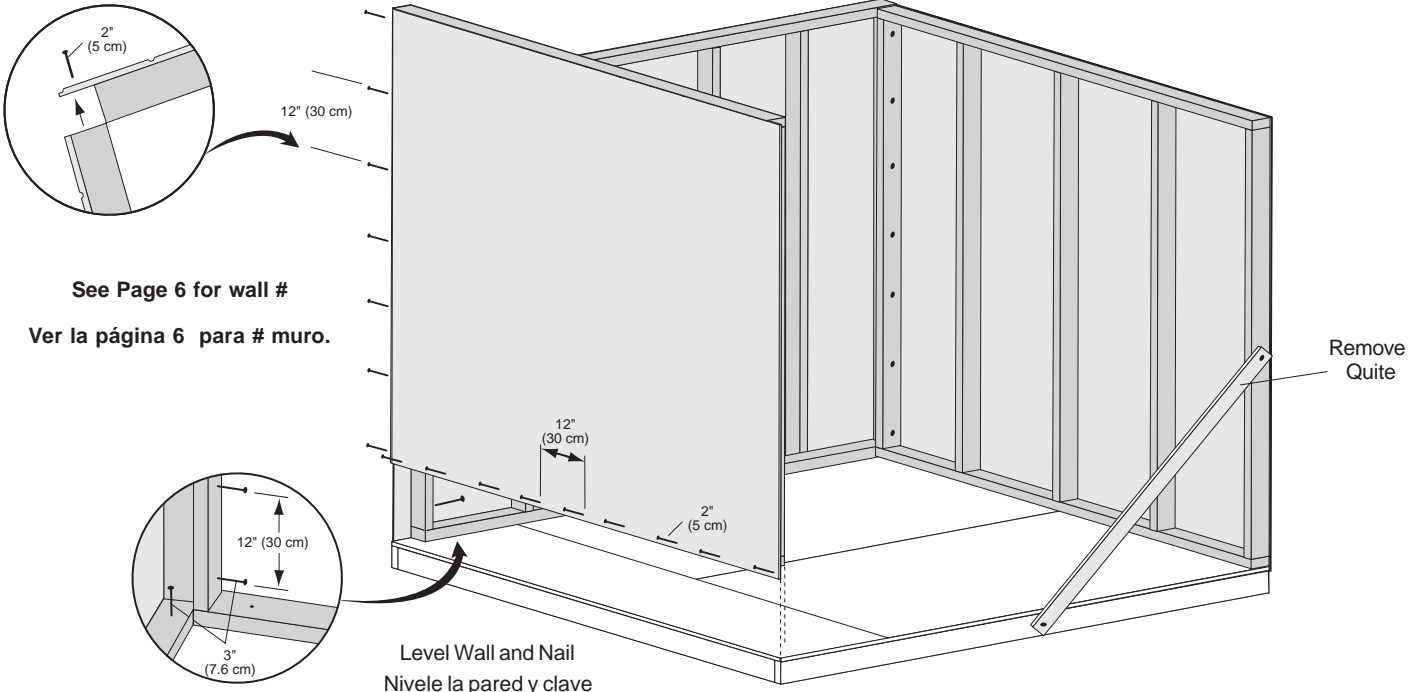

# ERECTING WALLS

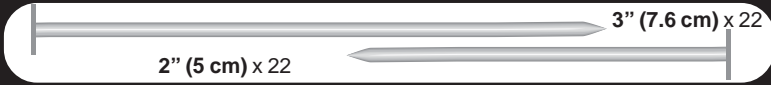

# CONSTRUYENDO LOS MUROS

After walls are erected, make sure X to X and Y to Y measurements are the same

Después de construir los muros, asegúrese que las medidas "X a X" y "Y a Y" son iguales.

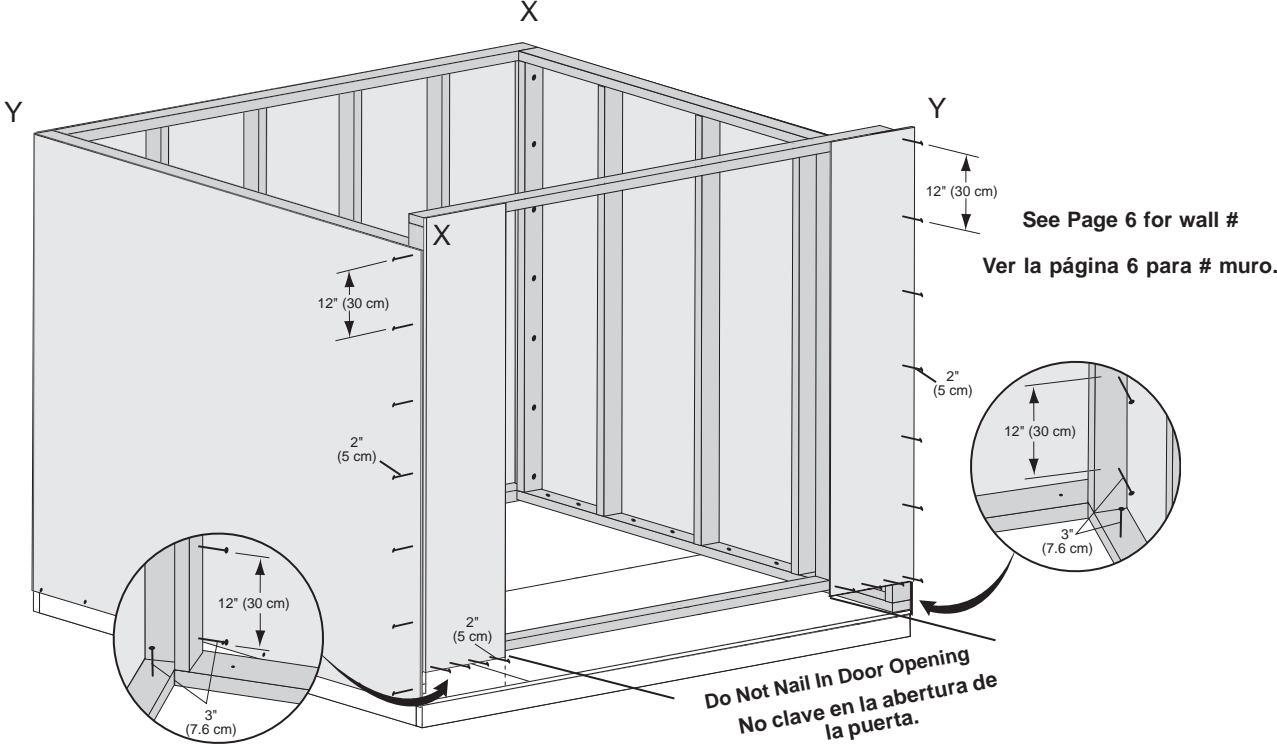

**DOUBLERS**

3" (7.6 cm)

x 48 (8'x8') (244 x 244 cm)  
 x 60 (8'x12') (244 x 366 cm)  
 x 72 (8'x16') (244 x 488 cm)

**DOBLADORES**

10' X 8' (305 x 244 cm)

**Install as Shown**  
**Instale como en el dibujo**

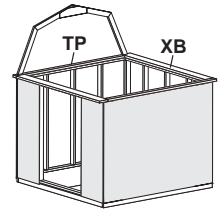
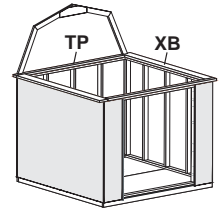
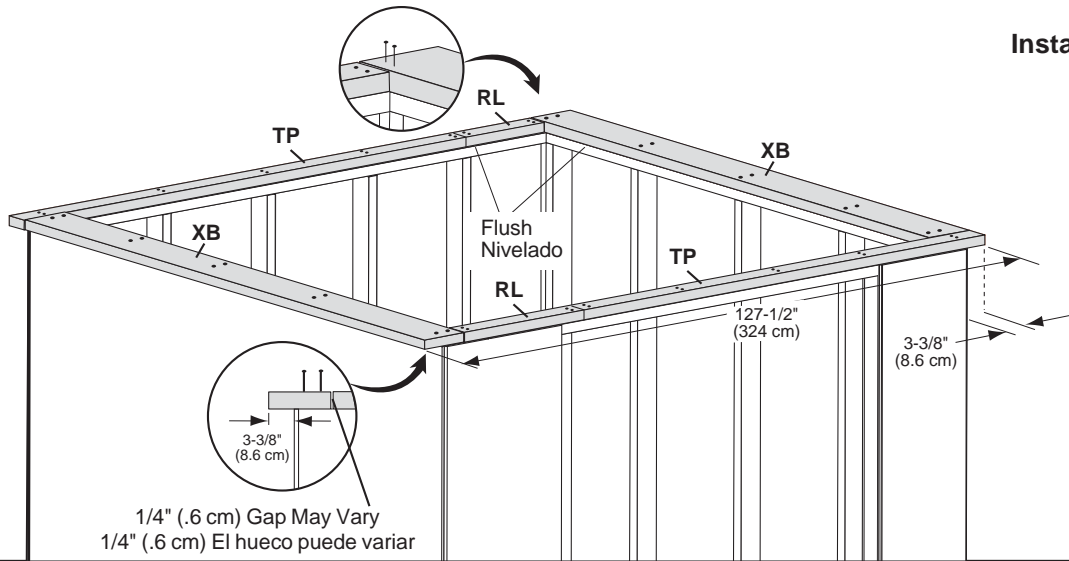

10' X 12' (305 x 366 cm)

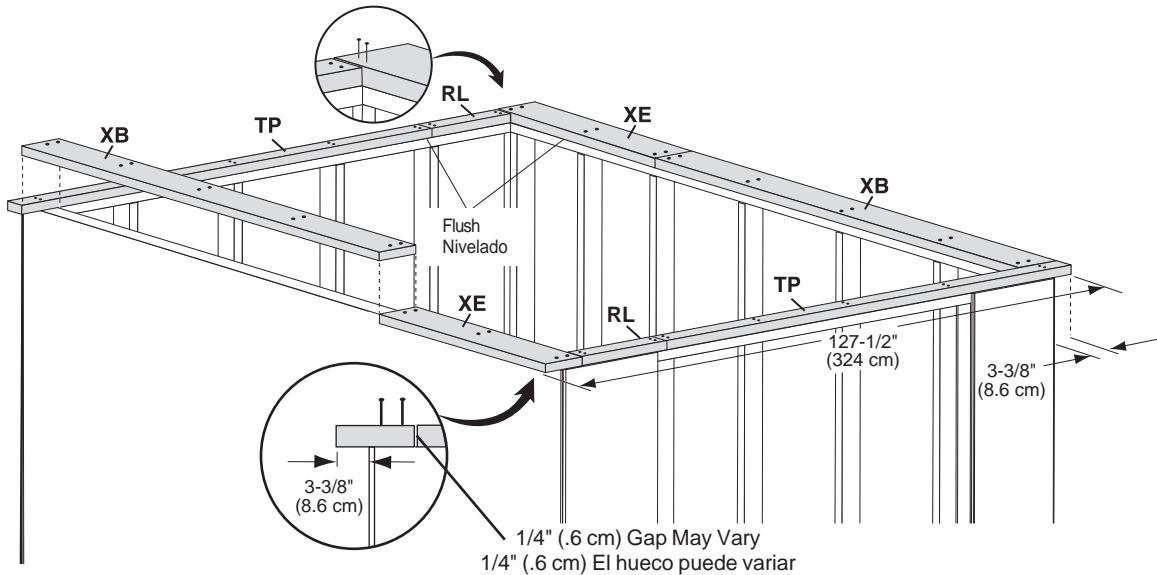

**IMPORTANT:** For wall #21 cut part XB, arrange pieces as shown

**IMPORTANTE:** Para la pared #21 parte del corte XB, arregla los pedazos como mostrado

10' X 16' (305 x 488 cm)

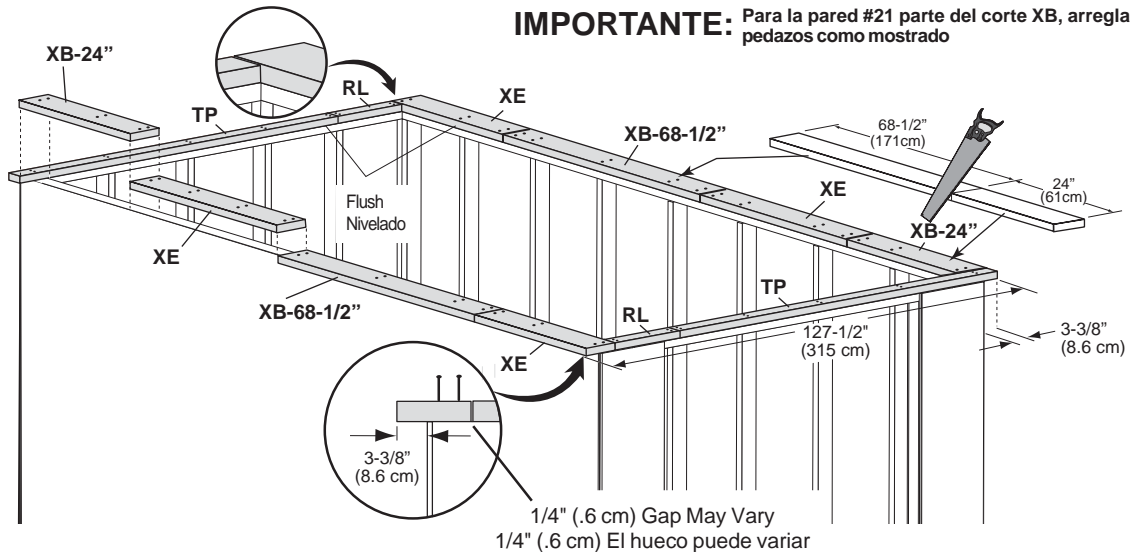

# ROOF

1-1/2" (3.8 cm)

x 12

# TECHO

## End Rafter Assembly x2

## Conjunto de vigas terminales x2

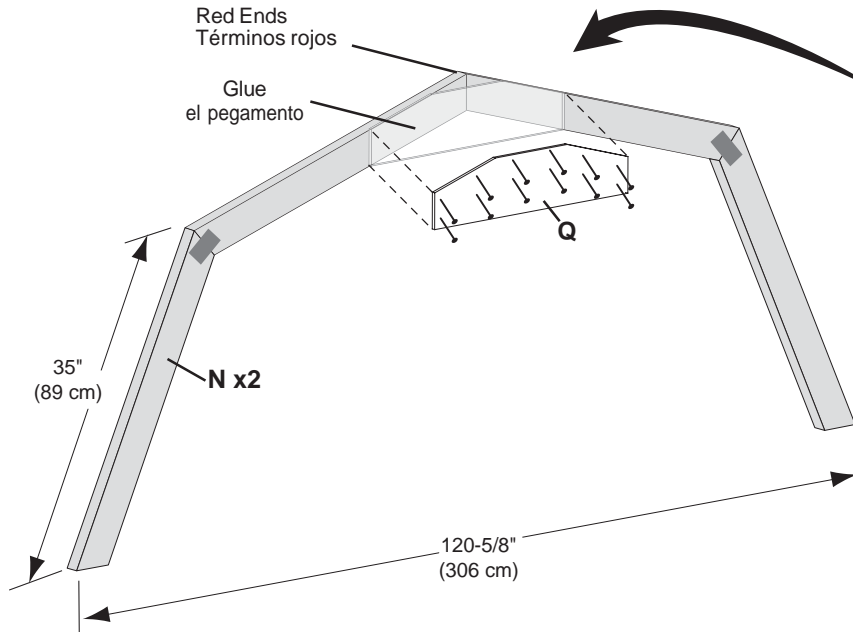

x2

# ROOF

1-1/2" (3.8 cm)

x 24

3" (7.6 cm)

x 8

# TECHO

## Middle Rafter Assembly (See sizes below for quantity)

## Conjunto de vigas centrales (Ver las dimensiones abajo para la cantidad)

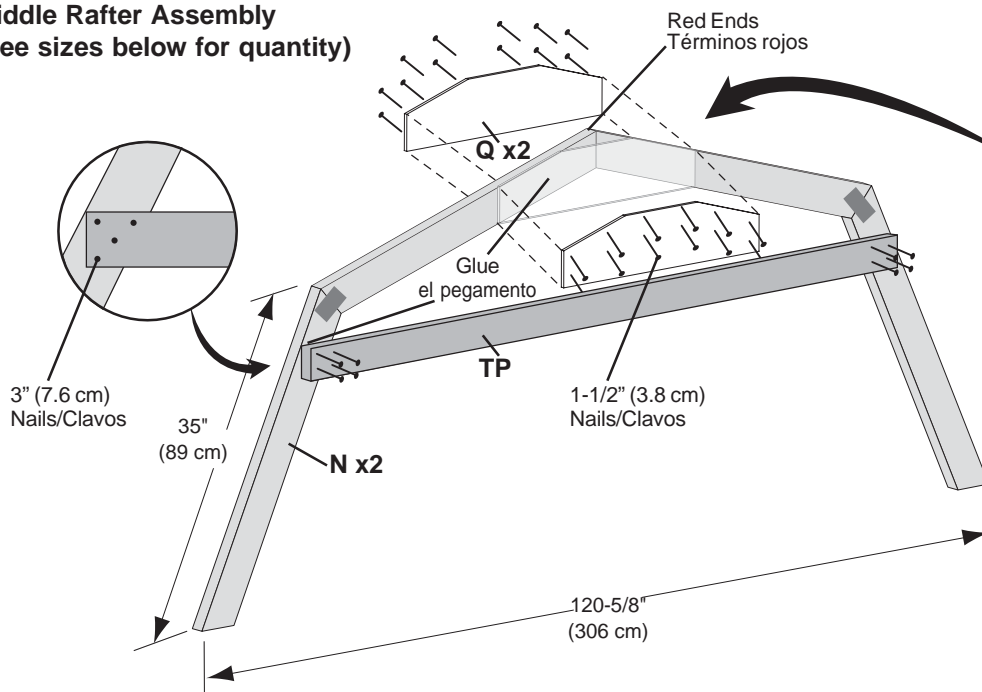

10'x8' (305 x 244 cm)

10'x12' (305 x 366 cm)

10'x16' (305 x 488 cm)

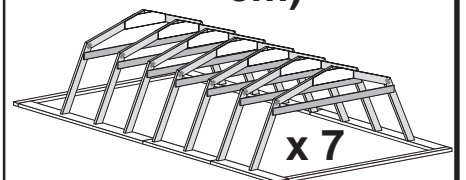
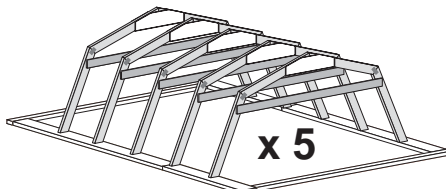
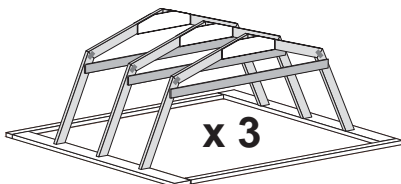

# ROOF

# TECHO

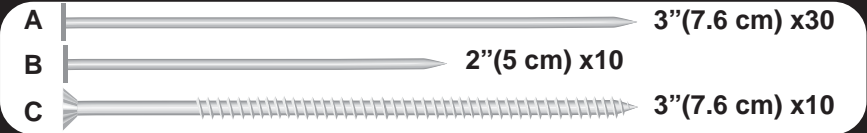

**Attaching Rafters and Soffit Blocks**  
(See below for dimensions)

**Fijando las vigas y los bloques del sofito.**  
(Ver abajo para las dimensiones.)

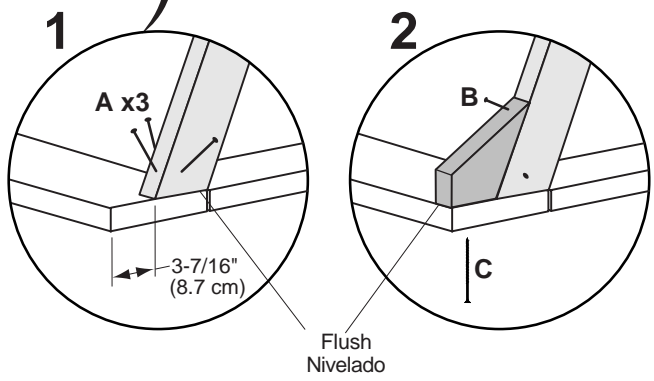
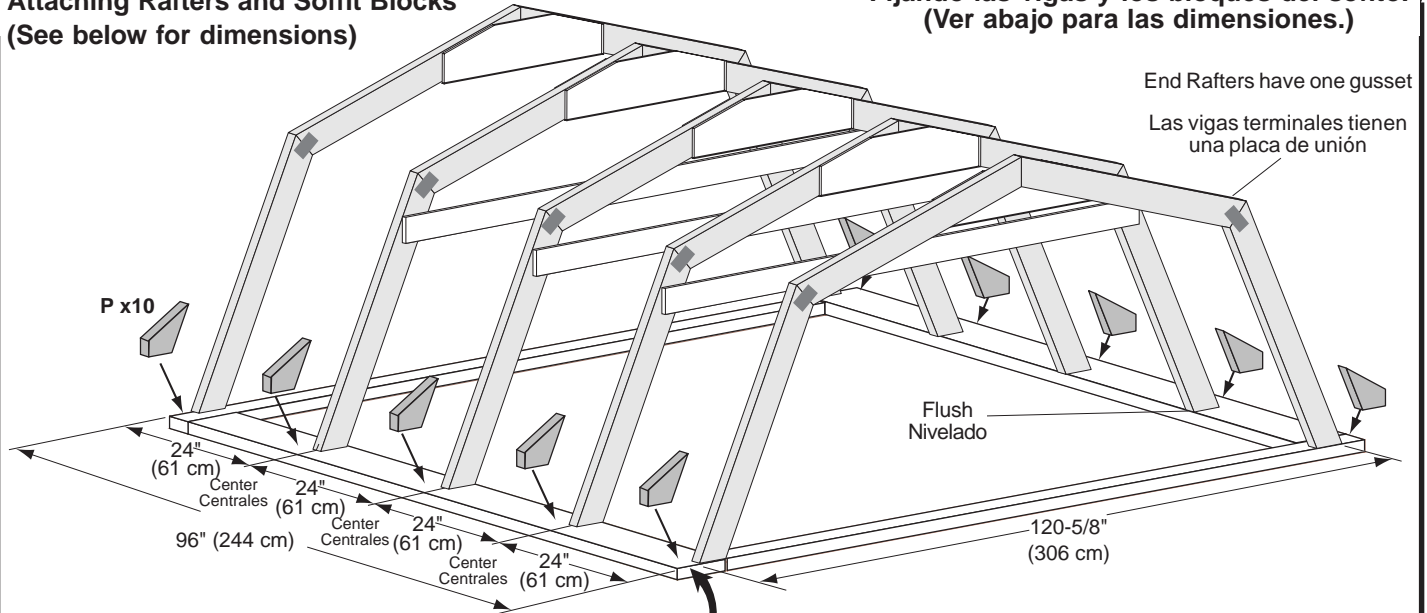

**10'x8' (305 x 244 cm) Shown / Indicado**

**10'x12' (305 x 366 cm)**

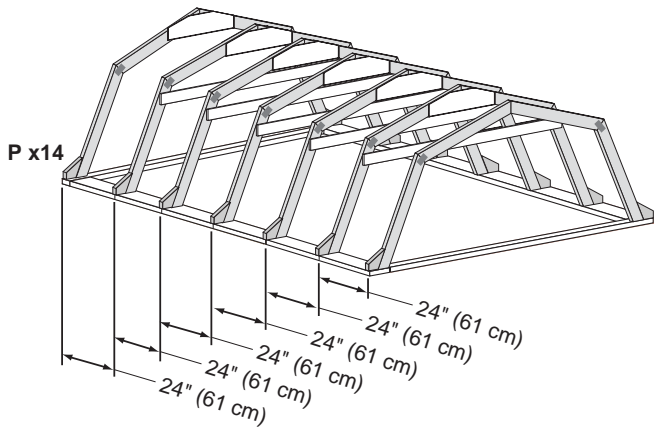

**10'x16' (305 x 488 cm)**

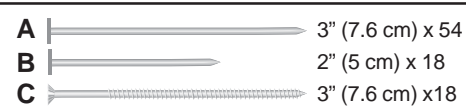
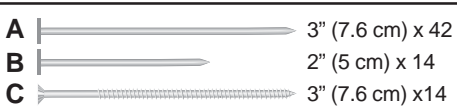
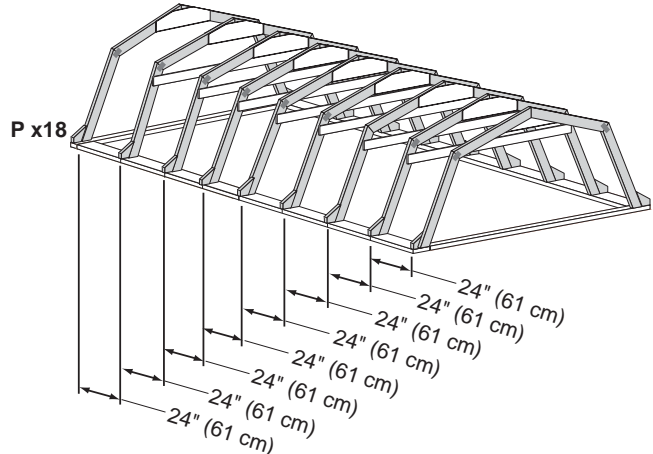

# ROOF

2"(5 cm)

x110

# TECHO

See Page 8 For Building Tip!!!

¡Ver la página 8 para un consejo!!!

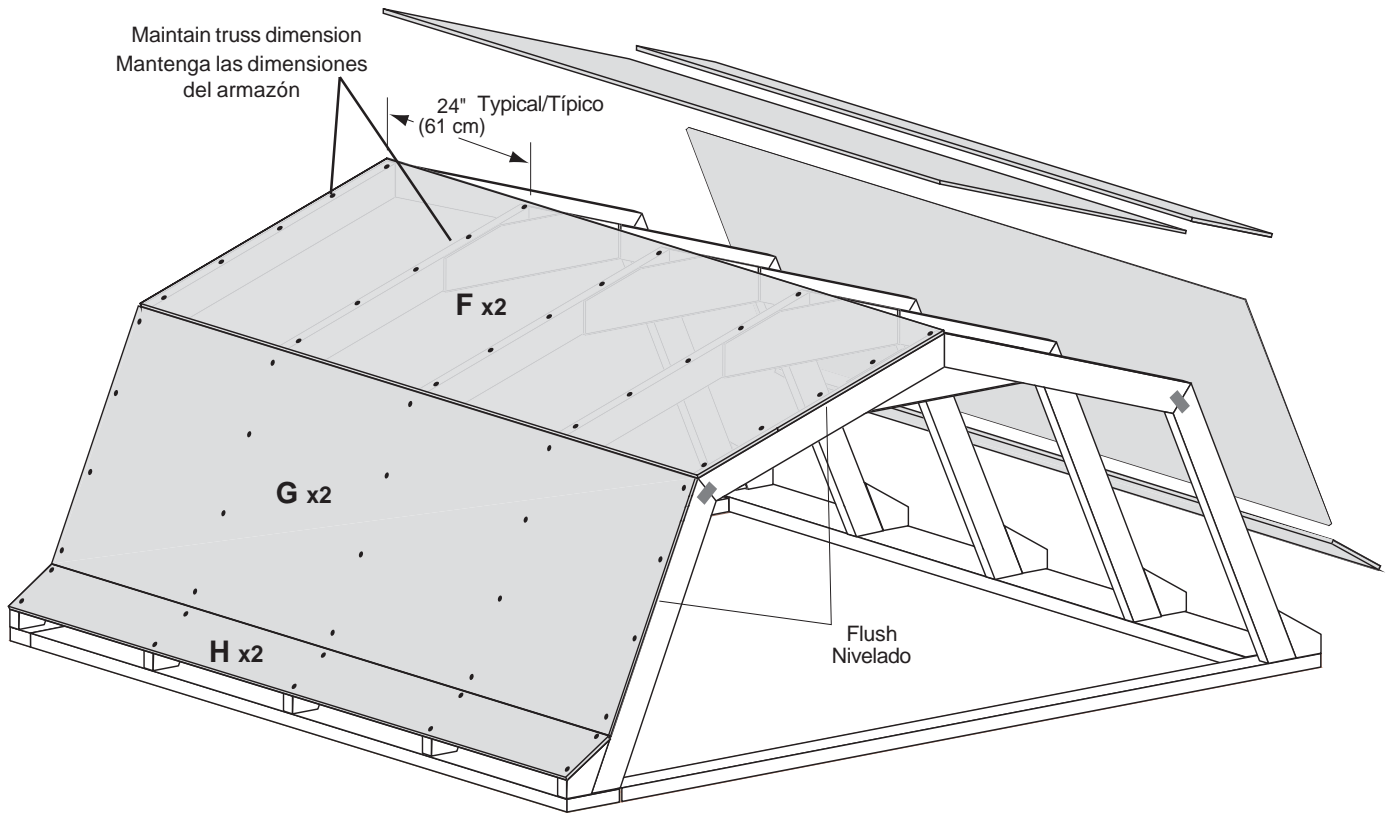

10'x8' (305 x 244 cm) Shown / Indicado

10'x12' (305 x 366 cm)

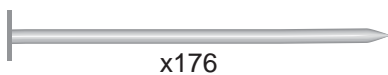
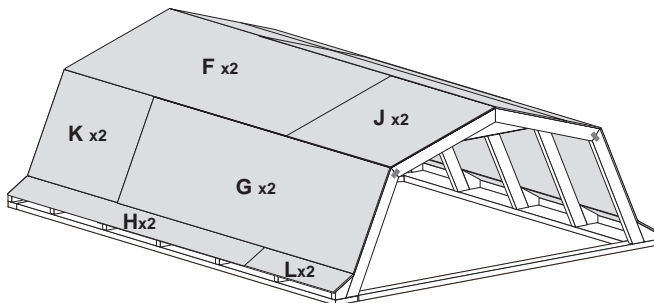

10'x16' (305 x 488cm)

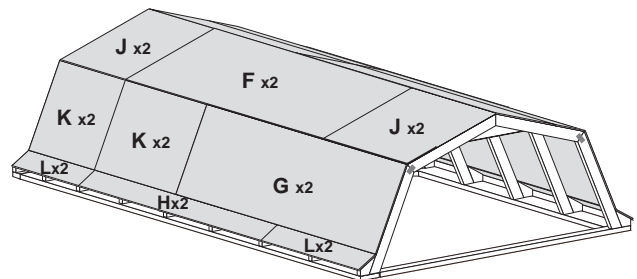

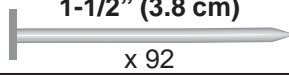

Gable Panels

Paneles del techo a dos aguas

DRY FIT PANELS AS SHOWN HERE BEFORE ASSEMBLING

Los paneles montan según lo visto

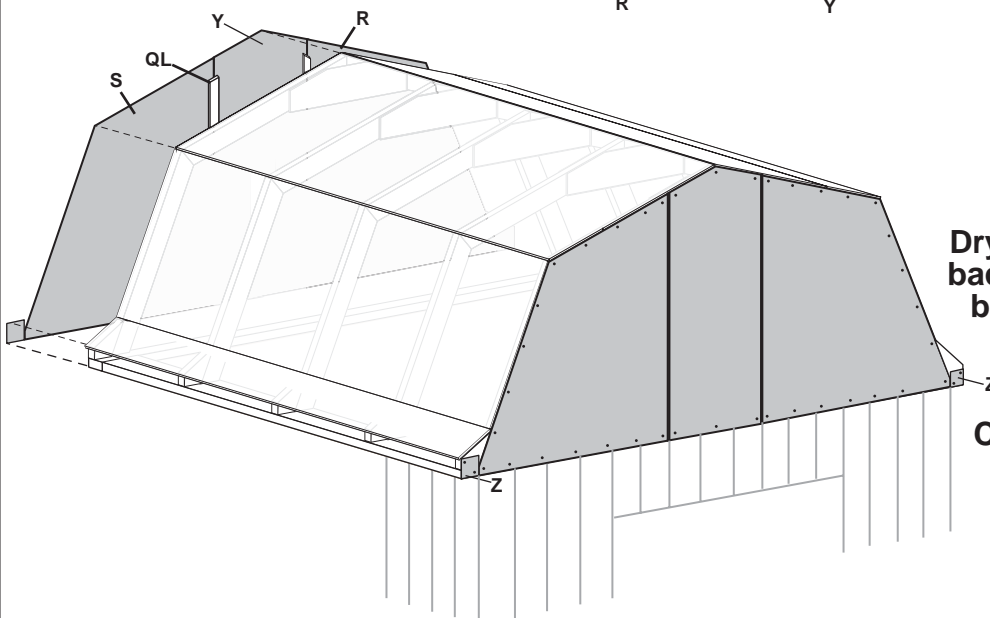
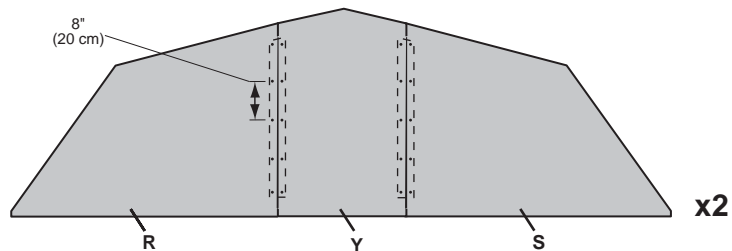
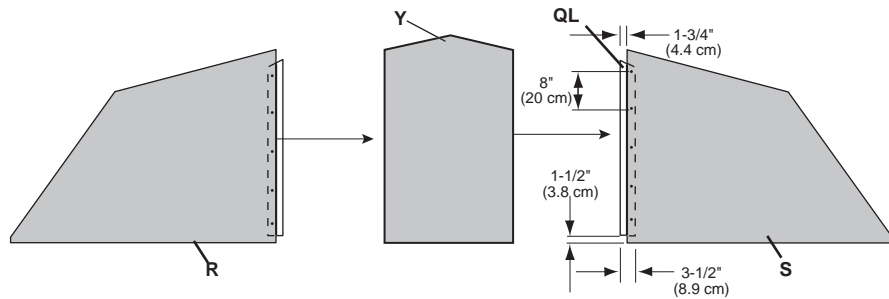
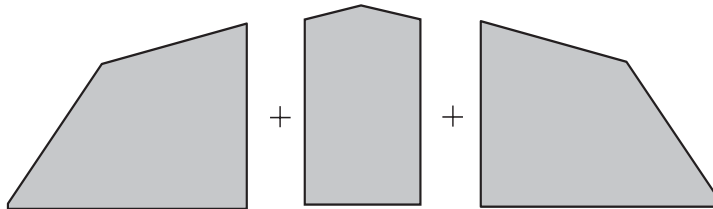

Dry fit assembly on front and back of building to determine best alignment of grooves

Compruebe la alineación del surco en frente y la parte posterior

TRIM

2"(5 cm)

x 150

3/4"(1.9 cm)

x 6

MOLDURA

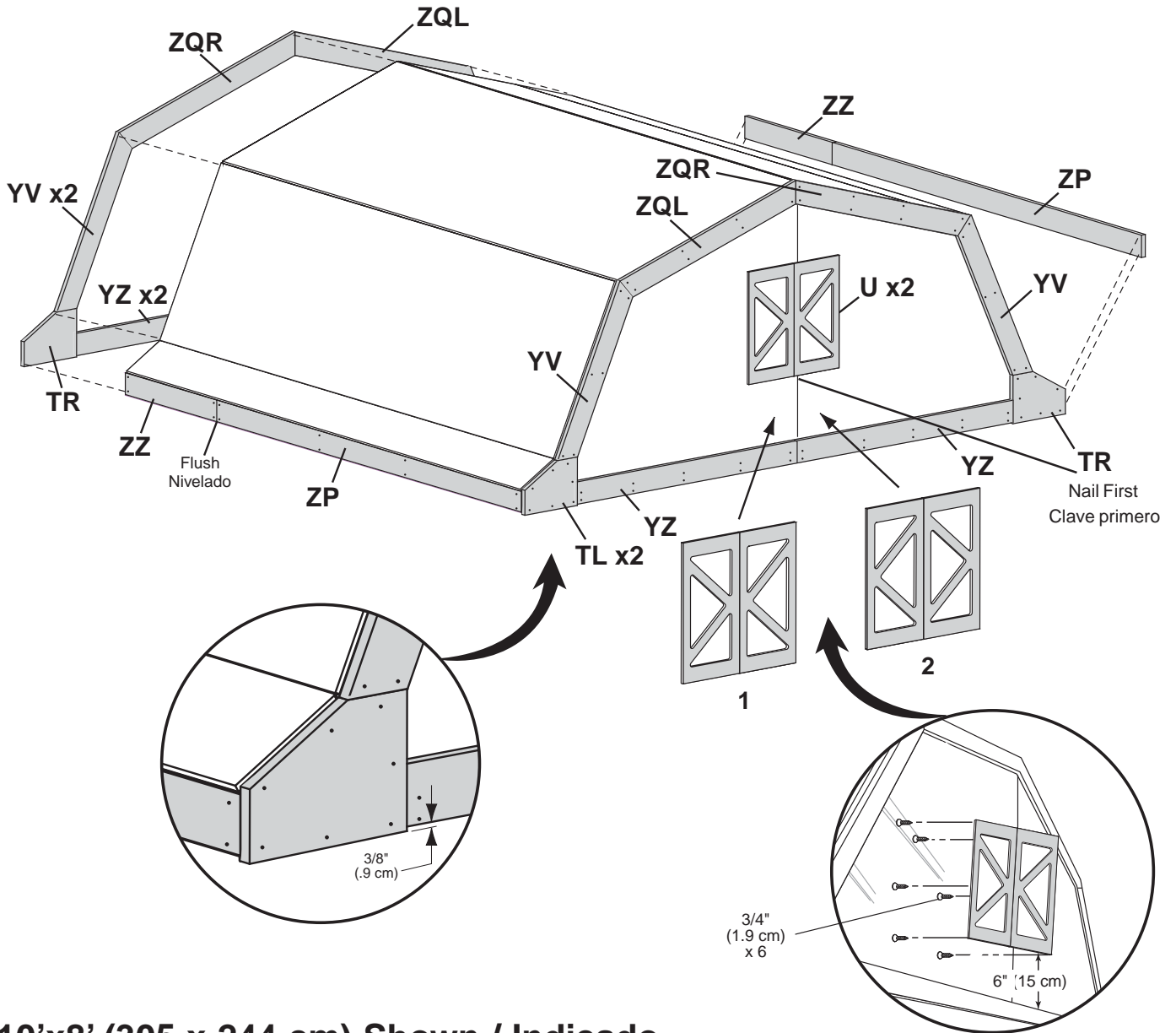

10'x8' (305 x 244 cm) Shown / Indicado

10'x12' (305 x 366cm)

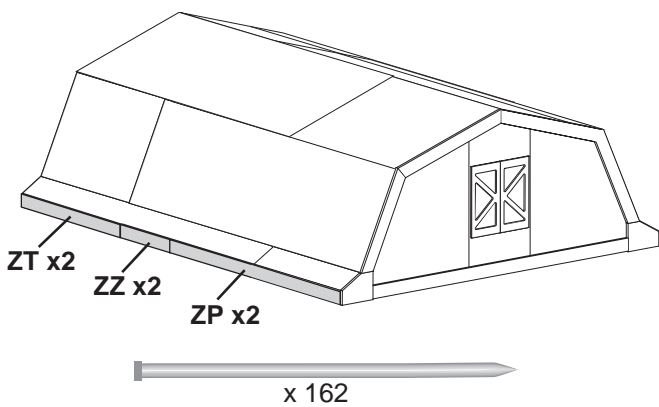

10'x16' (305 x 488 cm)

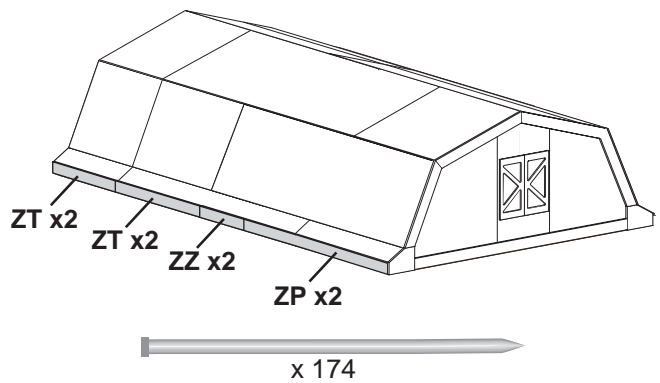



DOOR

1-5/8" (4.1 cm)



PUERTA

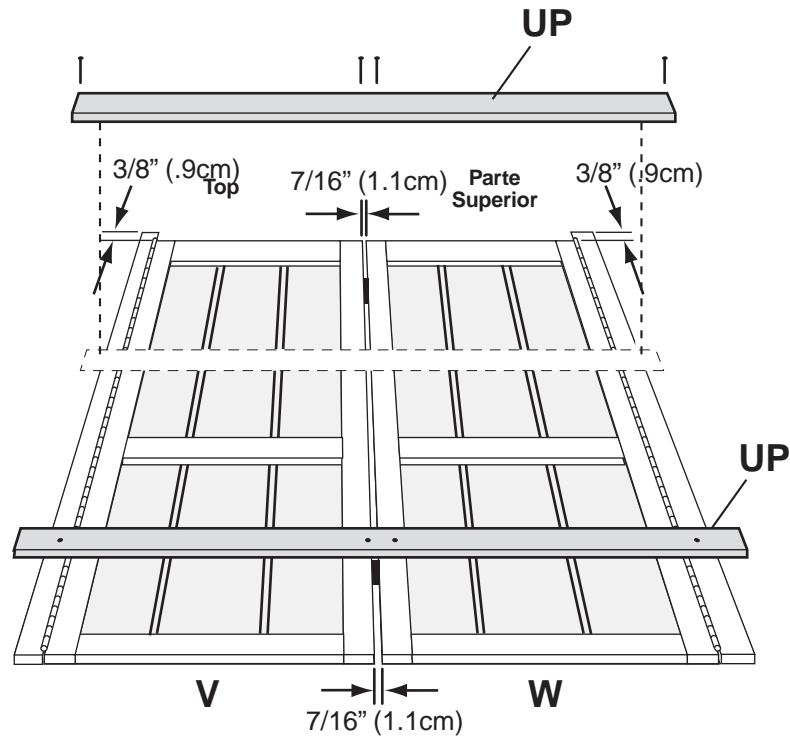

DOOR

PUERTA

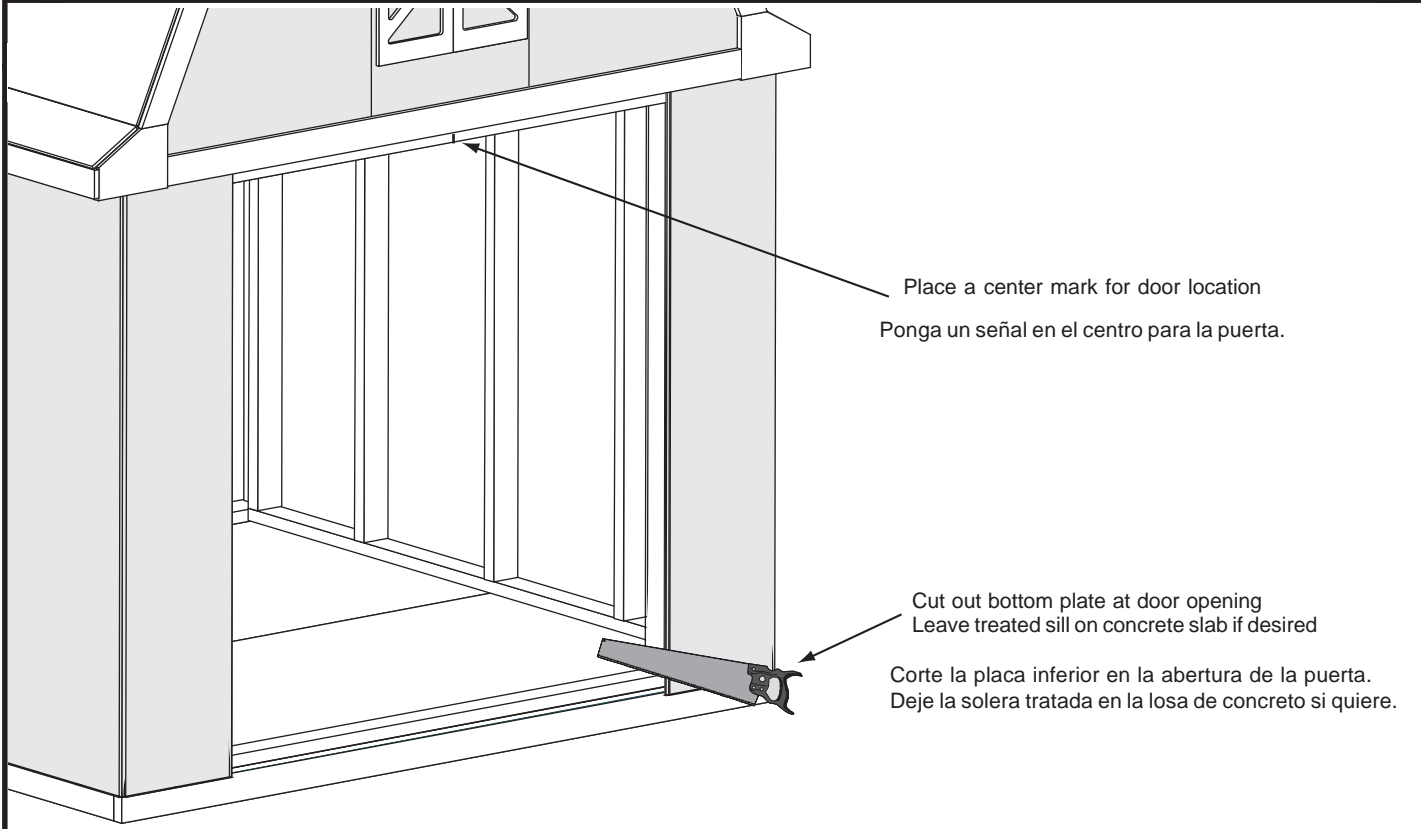

# DOOR

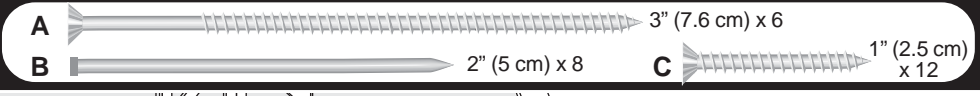

# PUERTA

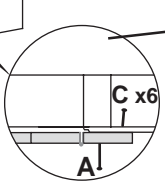
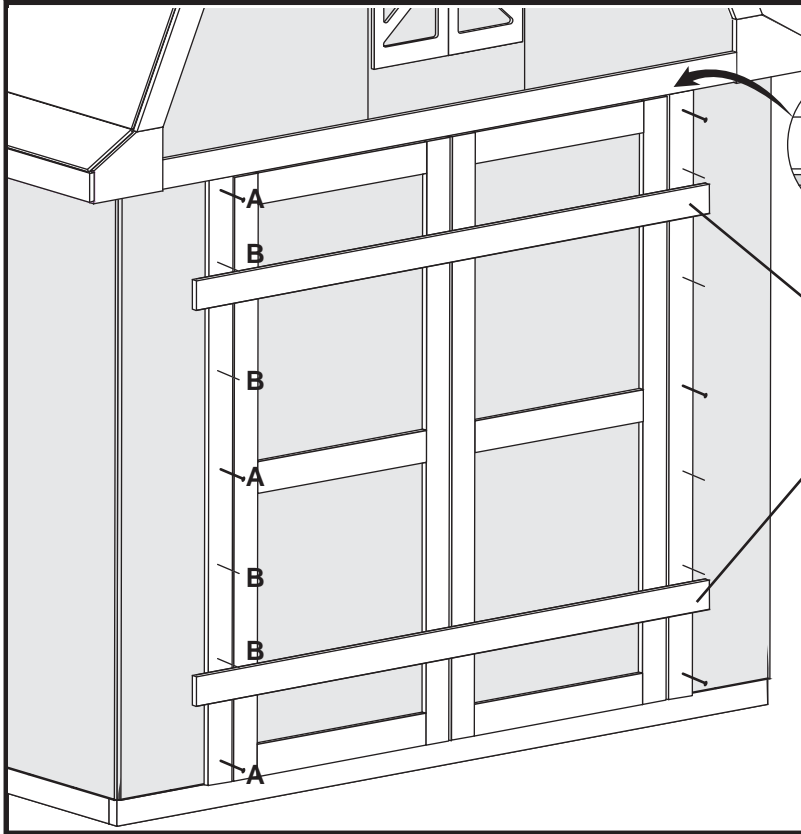

Inside Building  
Interior del edificio

Attach with 3" (7.6 cm) Screws first, remove X and Y, check doors to open properly and nail

Fije con tornillos de 3" (7.6 cm) primero, quite X y Y, compruebe que las puertas abren bien y clave.

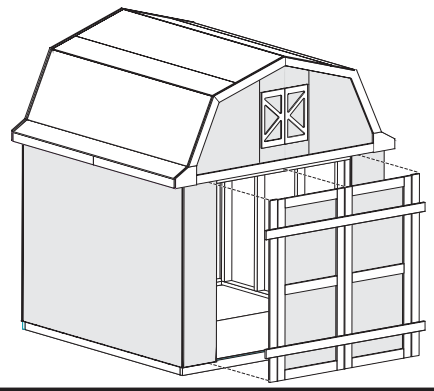

# TRIM

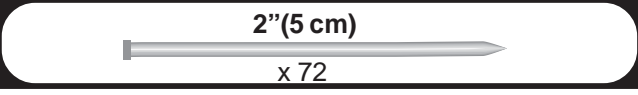

# MOLDURA

Do not sink nails completely.  
No hínque los clavos completamente.

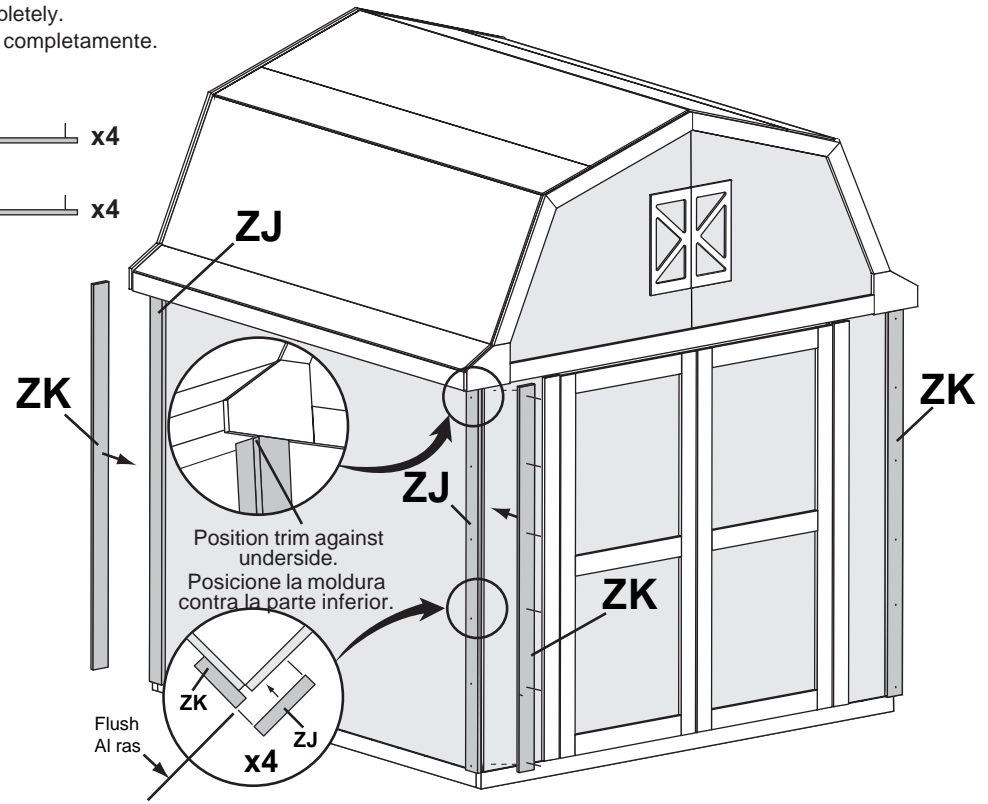
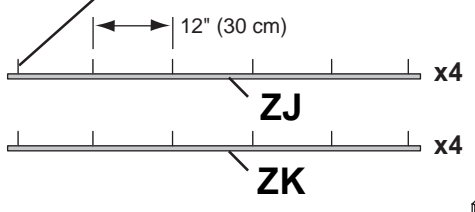

Position trim against underside.  
Posicione la moldura contra la parte inferior.

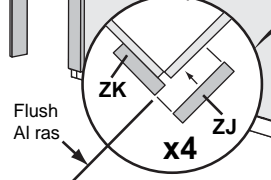

**DOOR**

**PUERTA**

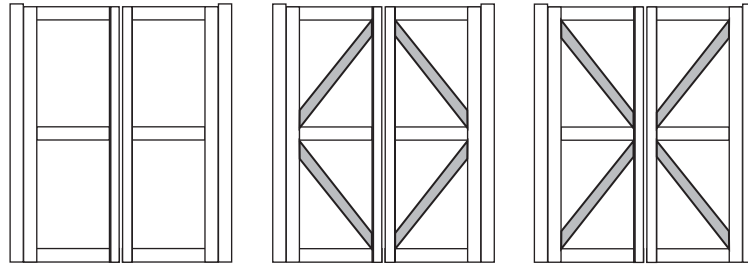
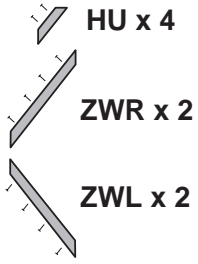

Plain

Diamond

Traditional X

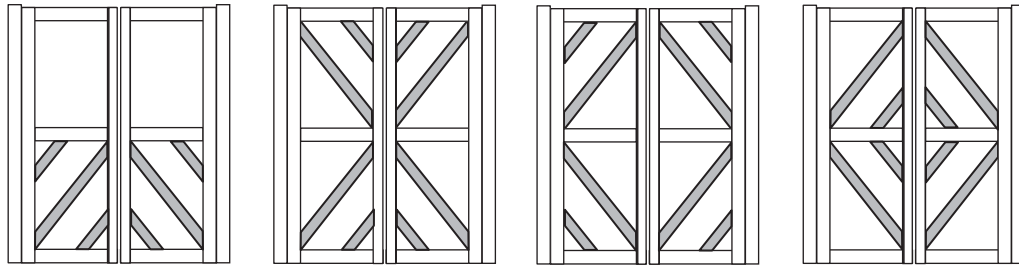

Contemporary

Double X

Outer Diamond

Inner Diamond

**DOOR**

**PUERTA**

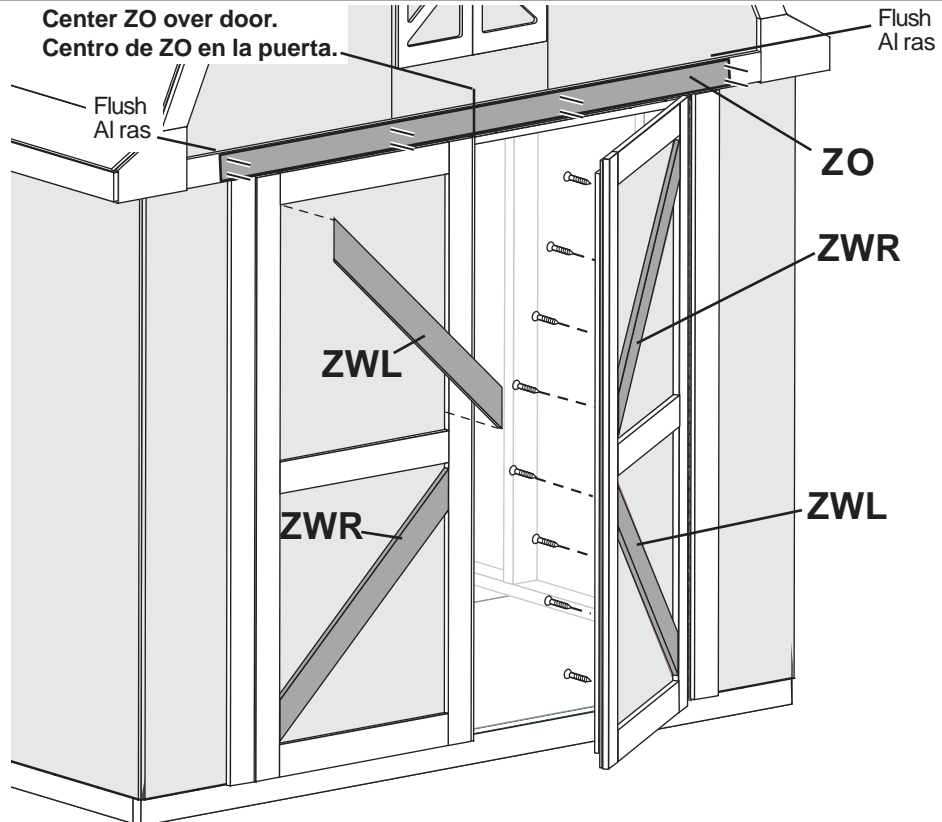
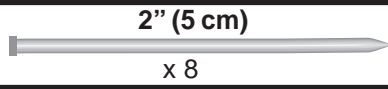
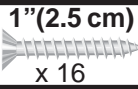

DOOR

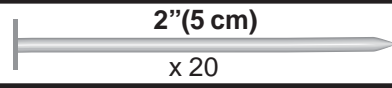
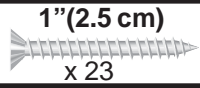

PUERTA

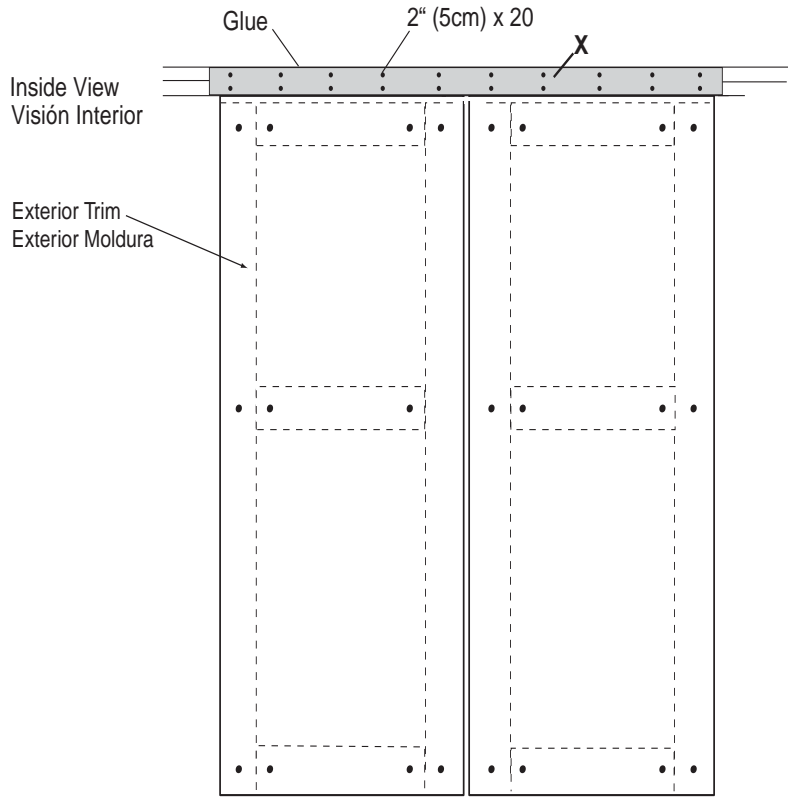

DOOR

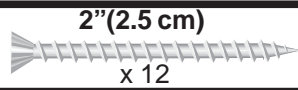

PUERTA

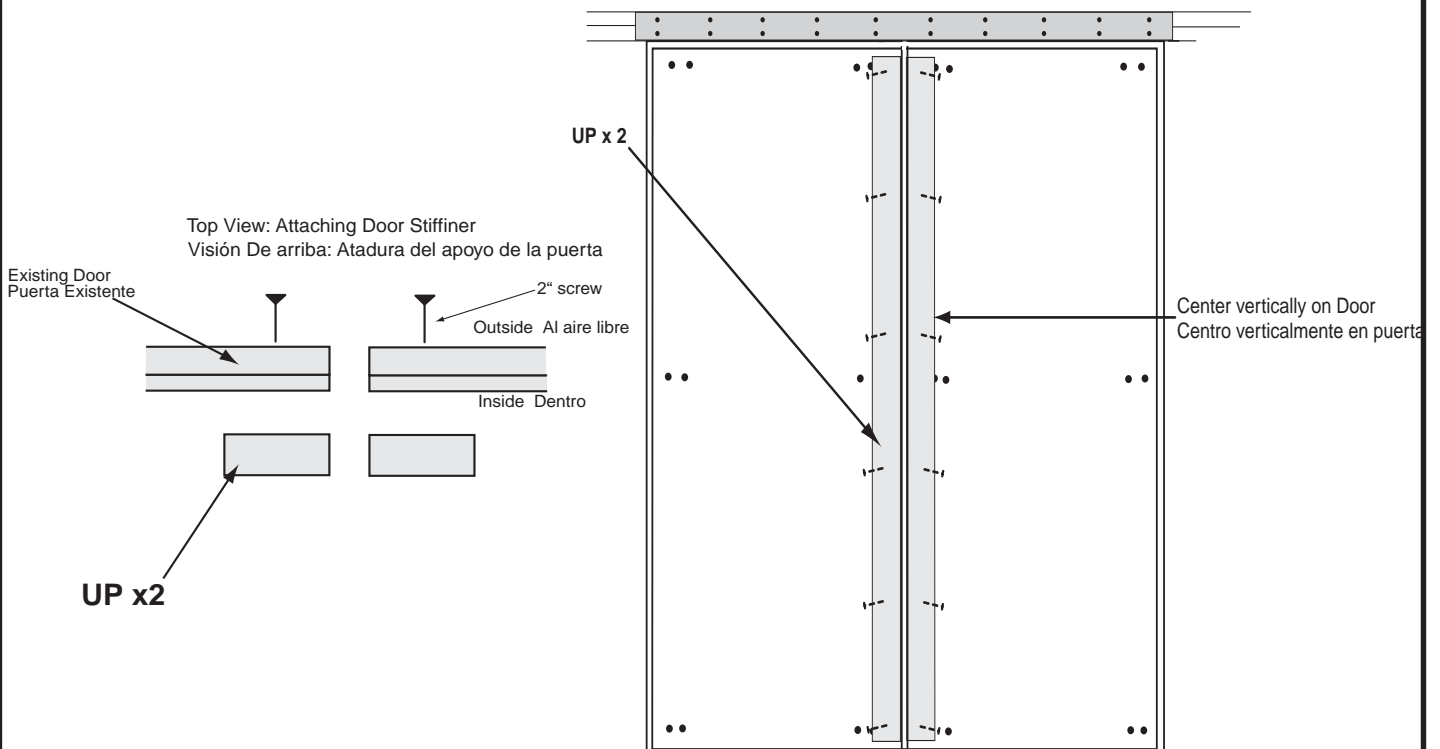

DOOR

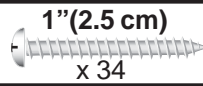

PUERTA

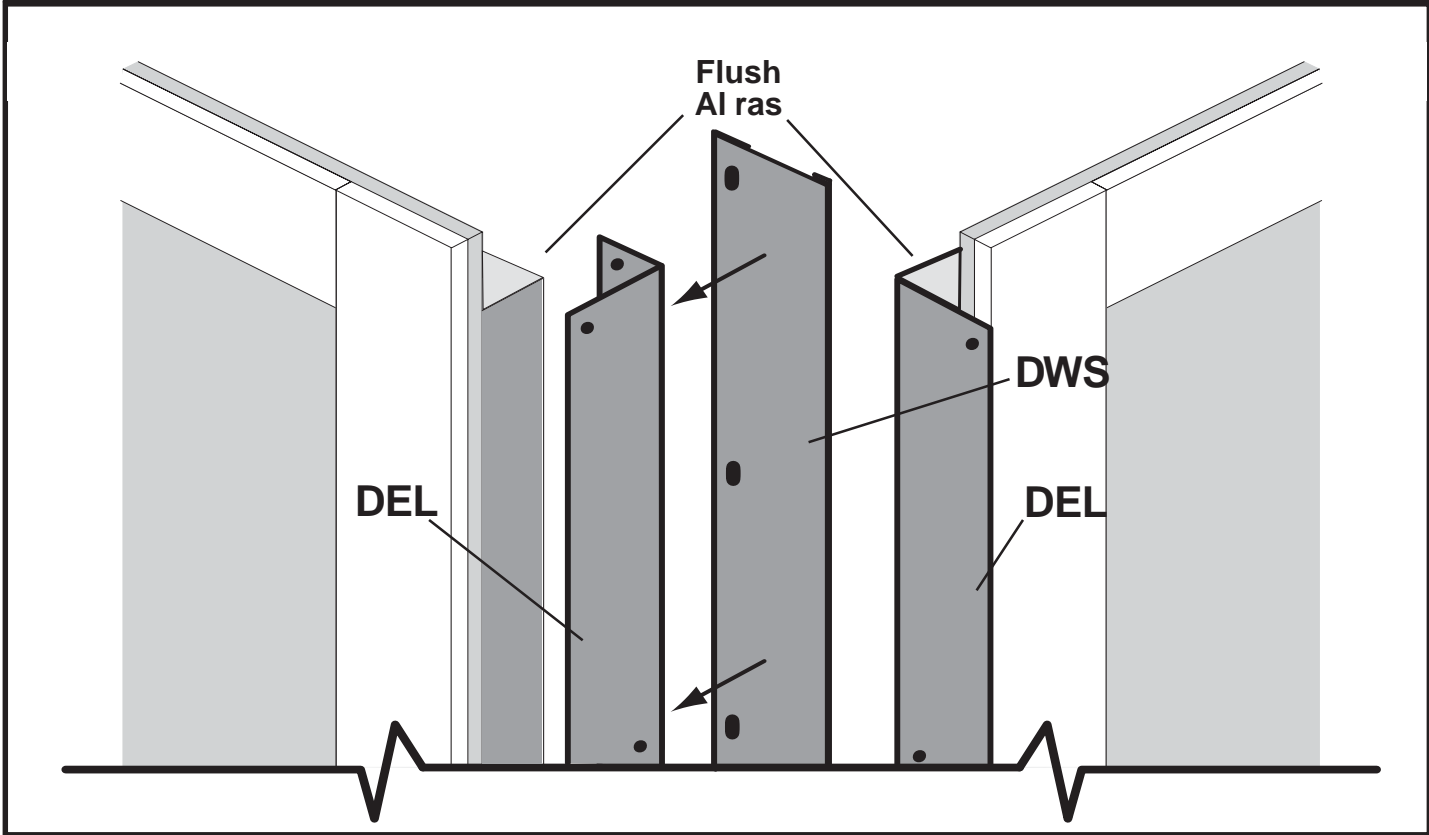

DOOR HANDLE

TIRADOR

1

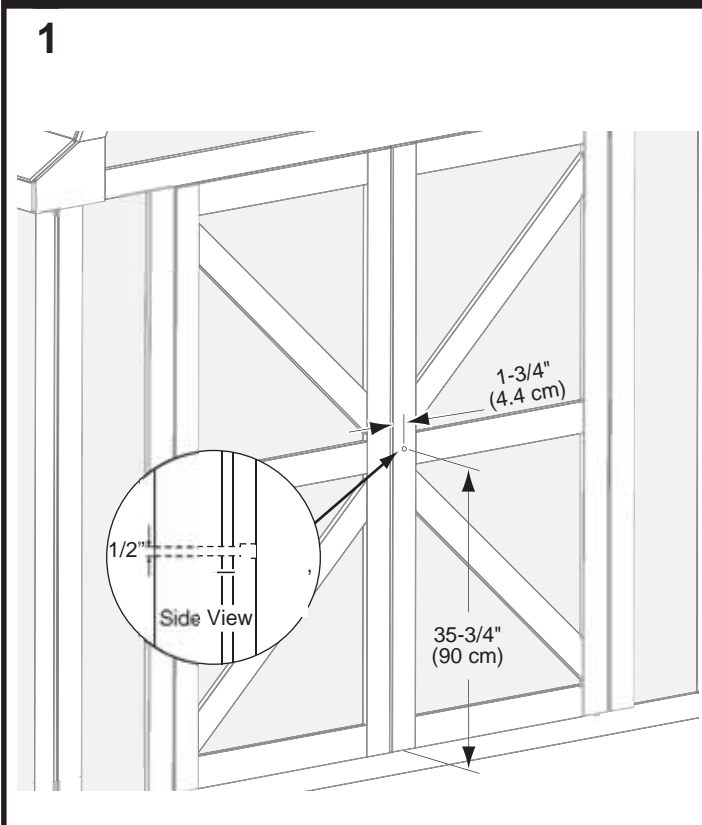

2

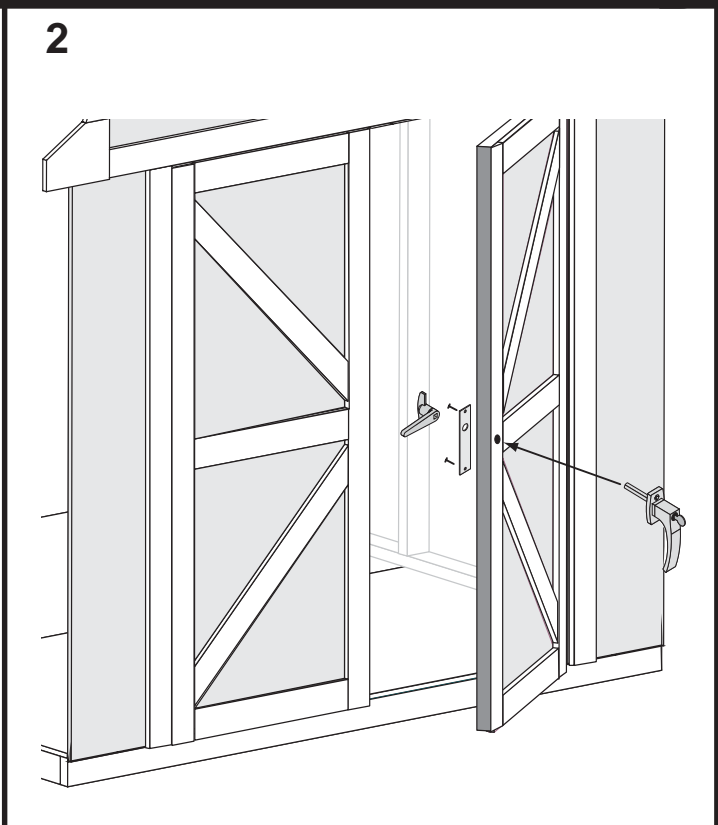

# HOOK AND EYE AND BARREL BOLT    ENGANCHE Y el OJO Y el BARRIL CIERRAN

Select Desired location for your Hook and Eye.

Seleccione la posición para el corchete

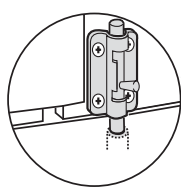
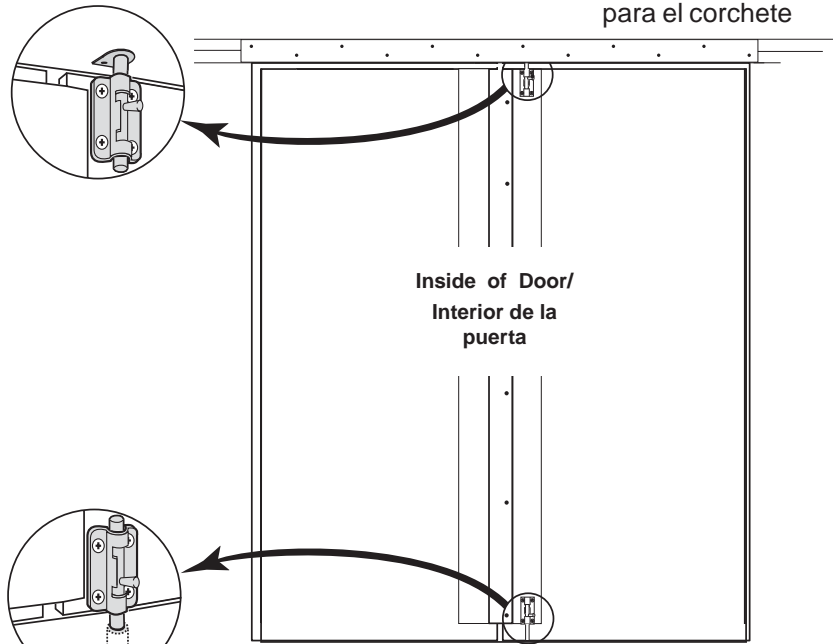

Drill hole 1/2" (1.3 cm) deep  
using 3/8" (.95 cm) bit

**NOTE: Install hook and eye into trim or stud.**

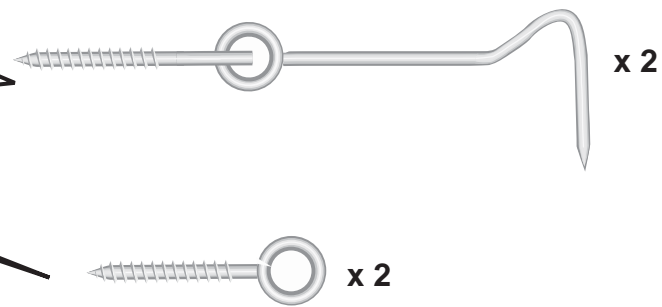
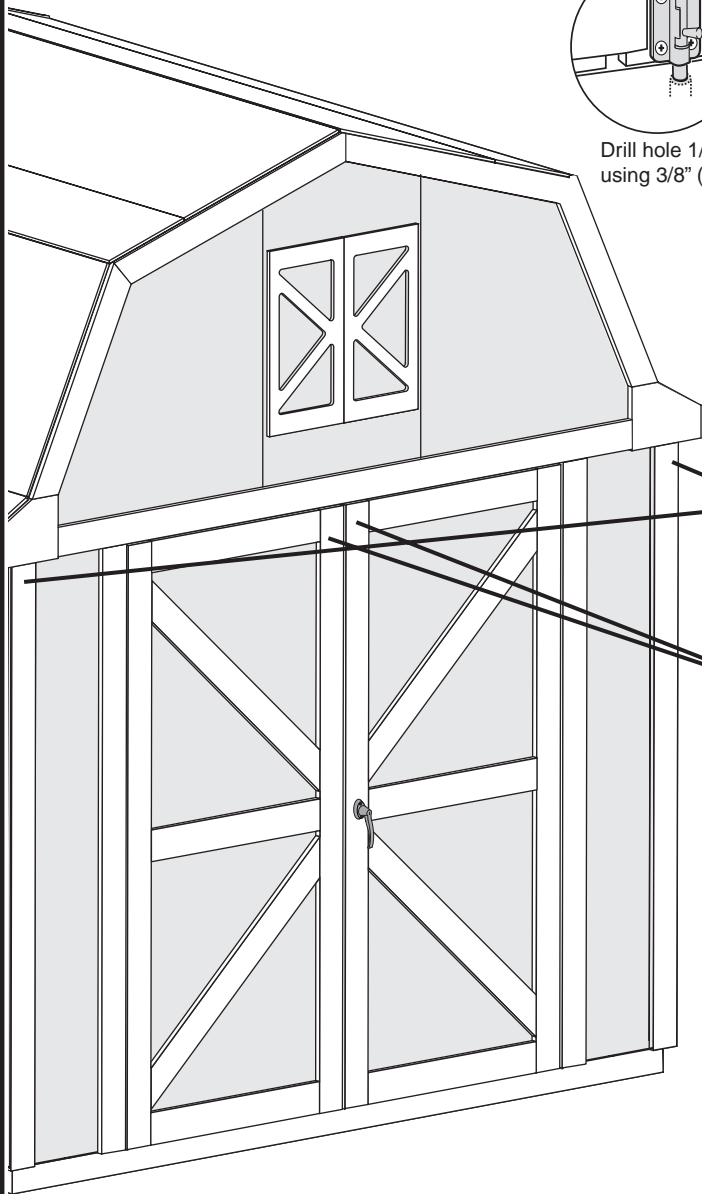

Hooks must go into trim or a stud  
Hay que fijar los corchetes a la  
moldura o un montante

## PAIN T AND CAULK (Not Included)

Use Acrylic Latex Caulk that is paintable. Caulk at all horizontal and vertical seams, between the Trim and Walls, and all around the Door Trim.

Use a high quality exterior acrylic latex paint. When painting your building, there are a few key areas that can be easily overlooked that **must** be painted:

- Bottom edge of all siding and trim
- Inside of doors and all 4 edges

Note: Prime all un-primed exterior wood before painting

## PINTURA Y MASILLADO (No Incluidas)

Use un masillado acrílico de latex que se puede pintar. Masille todas las juntas horizontales y verticales, entre la moldura y los muros, y alrededor de la moldura de la puerta.

Use una pintura acrílica de latex de alta calidad. Al pintar su edificio, hay unas areas claves que hay que pintar:

- El borde inferior de toda la cobertura y la moldura.
- El interior de la puerta y todos los 4 bordes de ésta.

Aviso: Ponga un imprimador en la madera exterior que no lo tiene antes de pintar.

Building Size Dimensiones del edificio	Building Paint Pintura del edificio	Trim Paint Pintura de moldura	Caulk Masillado
10' x 8' (305 x 244 cm)	2 Gallons/ galones	1 Quart/cuartas	2 Tubes/Tubos
10' x 12' (305 x 366 cm)	2-1/2 Gallons/ galones	1 Quart/cuartas	2 Tubes/Tubos
10' x 16' (305 x 488 cm)	3 Gallons/ galones	1 Quart/cuartas	2 Tubes/Tubos

## DRIP EDGE (Not Included)

Close up of drip edge  
Vista del gotero

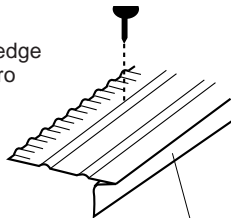

Side that hangs over  
side No Nails  
La parte que está  
colgada sobre un lado.  
No clavar.

## GOTERO DE BORDE (No Incluidas)

Snip bottom side of drip edge and  
Bend over to other side of Roof

Corte la parte inferior del gotero y  
dóblela sobre el otro lado del techo

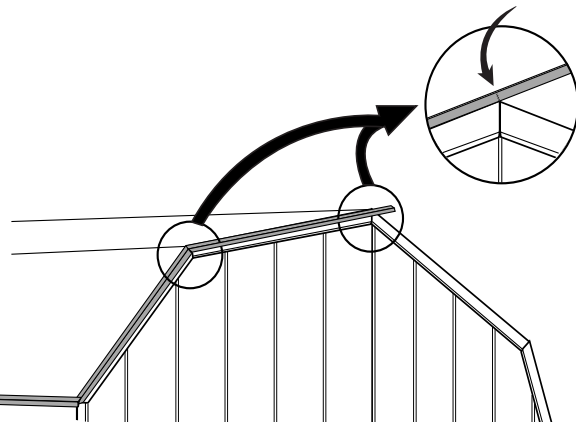

Building Size Dimensiones del edificio	Drip edge Gotero de borde
10' x 8' (305 x 244 cm)	50 feet/pies
10' x 12' (305 x 366 cm)	60 feet/pies
10' x 16' (305 x 488 cm)	70 feet/pies

# SHINGLES (Not Included)

Building Size Dimensiones del edificio	Shingles Needed Tejas Necesarias
10' x 8' (305 x 244 cm)	5 Bundles/bultos
10' x 12' (305 x 366 cm)	7 Bundles/bultos
10' x 16' (305 x 488 cm)	9 Bundles/bultos

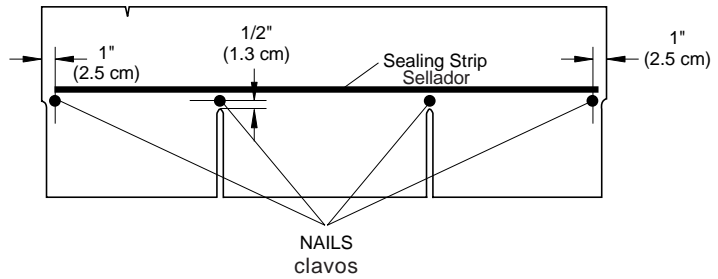

Install first row backwards  
Instale la primera fila al revés

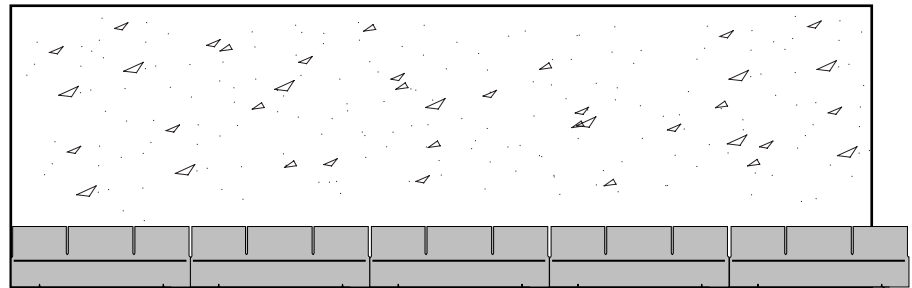

Flush to dripedge  
Nivelado al gotero

Okay if Shingle Overlaps

Está bien si la teja sobresale

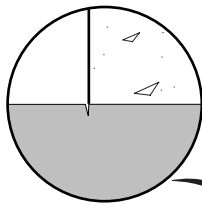

Line up notch on top of Shingle with edge of Roof to stagger the Shingles  
Alinee el corte encima de la teja con el borde del techo para escalonar las tejas.

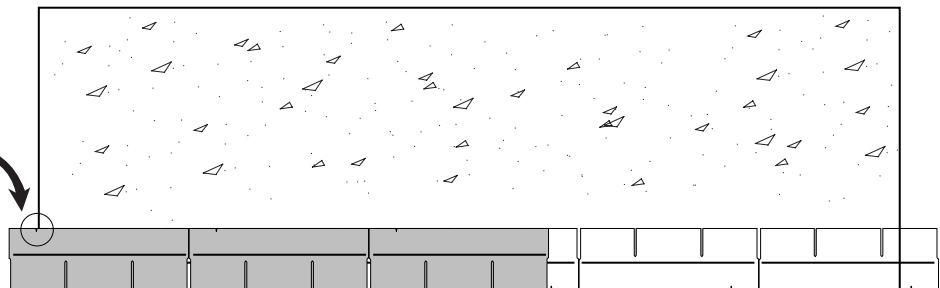

Maintain same dimension across  
Mantenga la misma dimensión de un lado al otro

Flush to edge, stagger each row  
Nivele al borde, escalone cada fila

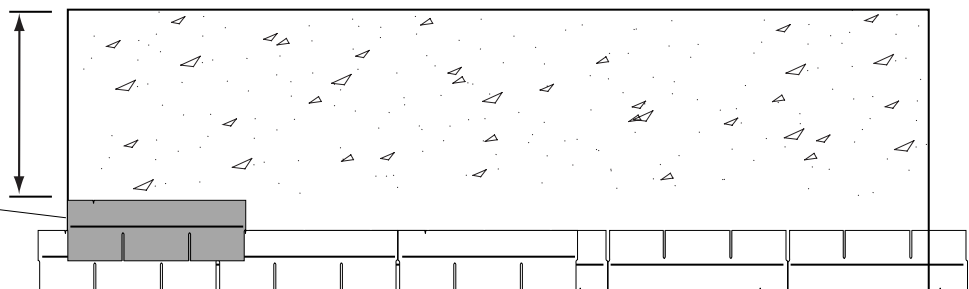

Remove overhanging shingles  
Quite tejas sobresalientes

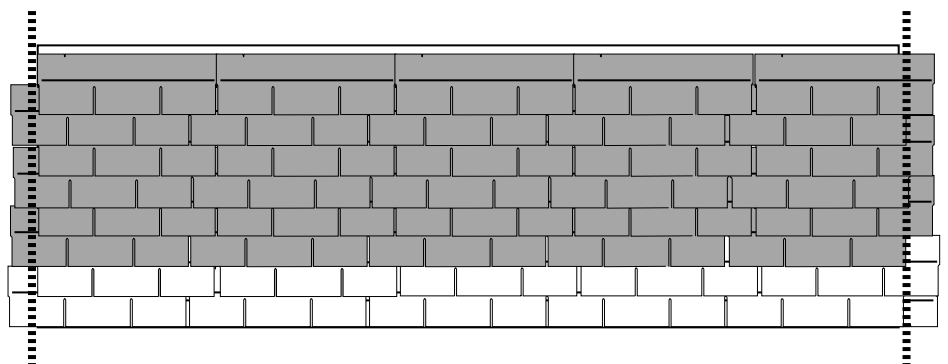



## SHINGLES (Not Included)

## TEJAS (No Incluidas)

### Ridge Cap

### Tapa de cumbre

Cut Shingles into 3 pieces  
Corte las tejas en tres partes

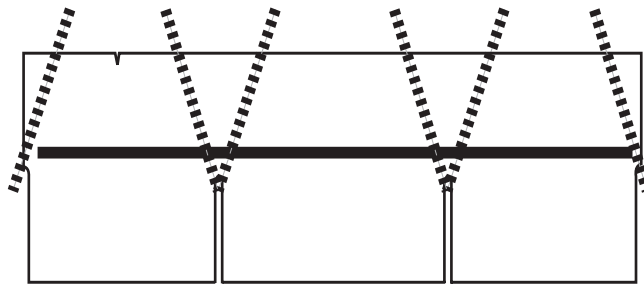

Apply pieces to ridge as shown  
Fije las piezas a la cumbre  
como en el dibujo

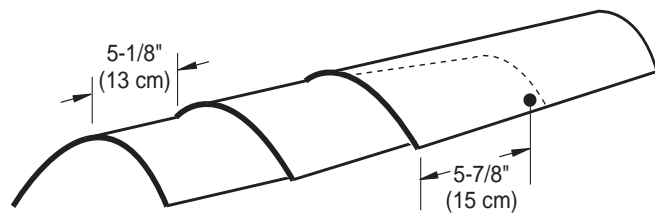

## NAIL INSPECTION INSECCIÓN DE CLAVOS

Check for protruding nails, pound any protruding nails into the wood or cut them off flush.

Inspeccione para clavos sobresalientes; hínque clavos sobresalientes en la madera or córtelos nivelados con la madera.

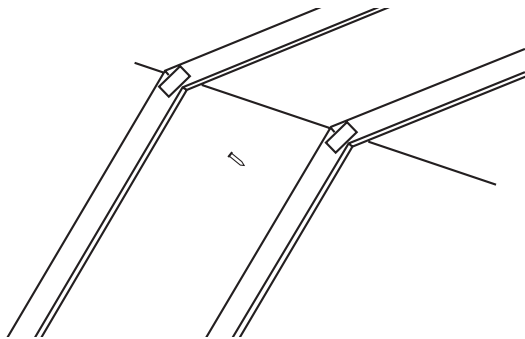

## REQUIRED MAINTENANCE MANTENIMIENTO NECESARIO

Keep grass trimmed and away from building  
Corte y quite la hierba cerca del edificio.

Keep Sprinklers away from building  
No use rociadores cerca del edificio.

Repaint building as needed and in accordance with paint manufacturer requirements  
Pinte el edificio de nuevo cada dos años.



**Limited Conditional  
Warranty \***

## WARRANTY

Backyard Storage Solutions, LLC warrants the following:

1. Every product is warranted from defects in workmanship and manufacturing for one year.
2. All hardware and metal components are warranted for two years.
3. Trim is warranted for 10 years.
4. Waferboard siding and sheathing is warranted for two years.
5. SmartSide™ siding is warranted for 10 years on all Marco series buildings and 15 years on all Premier Series buildings.
6. Timber series buildings' siding and trim are warranted for 10 years.
7. Solar Shed windows are warranted for 1 year.
8. Cedar lumber is warranted for 15 years.
9. Cedar doors and Cedar Garden Center are warranted for 10 years.
10. Metal roof is warranted for 25 years.

Backyard Storage Solutions, LLC will repair, replace or pay for the affected part. In no event shall Backyard Storage Solutions, LLC pay the cost of labor or installation or any other costs related thereto. All warranties are from date of purchase. If a cash refund is paid on an affected part, it will be prorated from the date of purchase.

## CONDITIONS

The warranty is effective only when:

1. The unit has been erected in accordance with the assembly instructions.
2. The unit has been properly shingled and painted or stained and reasonably and regularly maintained thereafter.
3. The failure occurs when the unit is owned by the original purchaser.
4. Backyard Storage Solutions, LLC has received the warranty registration card within thirty (30) days of purchase and notification of the failure in writing within the warranty period specified above.
5. Backyard Storage Solutions, LLC has had reasonable opportunity during the sixty (60) days following receipt of notification to inspect and verify the failure prior to commencement of any repair work.

## REQUIREMENTS

### Storage Buildings & Playhouses

To validate your warranty, it is necessary to properly maintain your Backyard Storage Solutions, LLC unit; shingle the roof and paint or solid-colored stain the siding using 100% acrylic latex exterior product with a minimum of two (2) coats within sixty (60) days of assembly; caulk above all doors and all horizontal and vertical trim boards; paint and seal all exposed edges, sides and faces of SmartSide™ and waferboard siding to include all exterior walls and all sides and all edges of doors.

### Gazebos, Pergolas & Timber Buildings

To validate your warranty, it is necessary to properly maintain your Backyard Storage Solutions, LLC unit. This includes treating all of the exposed cedar and pine surfaces on your gazebo or timber building with an exterior grade wood preservative, an exterior oil-based semi-transparent stain, an acrylic latex exterior paint or an acrylic latex solid color exterior stain within 30 days of assembly and as needed thereafter to maintain your warranty.

Keep vegetation trimmed away from building and make sure siding panels and trim do not come in contact with masonry or cement. The minimum ground clearance for siding must be one half inch (½ inch) from concrete slab or two and one half inches (2 ½") from the ground when building is erected or constructed on a treated wood floor kit. Water from sprinklers must be kept off unit. In no event will Backyard Storage Solutions, LLC be responsible for any indirect, incidental, consequential or special damages nor for failure(s) that are caused by events, acts or omissions beyond our control including, but not limited to, misuse or improper assembly, improper maintenance (which eventually leads to rot or decay) and acts of God. Backyard Storage Solutions, LLC will not be held responsible for any labor costs incurred to construct your unit.

This warranty gives you certain specific rights that vary from state to state.

## CLAIM PROCEDURE

To make a claim under this warranty, you can either call 1-888-827-9056 or prepare a letter. Please have ready the information below when you call or include the information when writing:

1. The model and size of the product.
2. A list of the part(s) for which the claim is made.
3. Proof of purchase of the Backyard Storage Solutions, LLC item, as shown on the original invoice.
4. Run code, as listed on the yellow warranty card enclosed in the product package.

Mail the above information to:

Backyard Storage Solutions, LLC  
Attn: Customer Service  
1000 Ternes  
Monroe, MI 48162

**\*WARRANTY TERMS MAY VARY OUTSIDE THE U.S.A.**

**IMPORTANT: This is your warranty certificate.**

**Please complete and mail your warranty card to properly validate your warranty.**

**Garantía Limitada  
Condiciona l \***

Backyard Storage Solutions, LLC le garantiza a Ud. que:

1. Cada producto no tiene defecto de mano de obra ni de manufactura por un período de un año.
2. La ferretería y los componentes de metal están garantizados por dos años.
3. La moldura está garantizada por 10 años.
4. La cobertura y el entablado están garantizados por dos años.
5. La cobertura SmartSide™ está garantizada por 10 años para los edificios Marco Series, y por 15 años para los edificios Premier Series.
6. La cobertura y la moldura de los edificios Timber Series están garantizadas por 10 años.
7. Las ventanas del Solar Shed están garantizadas por un año.
8. La madera de cedro está garantizada por 15 años.
9. Las puertas del cedro y el Centro de jardín del Cedro son justificados durante 10 años.
10. El techo del metal es justificado durante 25 años.

Backyard Storage Solutions, LLC reparará, cambiará o pagará por la pieza afectada. En ningún caso pagará Backyard Storage Solutions, LLC los gastos de instalación o trabajo manual, o cualesquiera otros gastos relacionados a eso.

#### Condiciones

Esta garantía es válida solo cuando:

1. La unidad ha sido construida según las instrucciones.
2. La unidad ha sido cubierta de tejas y pintada de manera correcta y mantenida regularmente.
3. El defecto ocurre mientras la unidad está en la posesión del comprador original.
4. Backyard Storage Solutions, LLC ha recibido la tarjeta de garantía del producto en el plazo de 30 (treinta) días después de comprar la unidad y después de la notificación del defecto por escrito, durante el período de vigencia de la garantía especificada arriba.
5. Backyard Storage Solutions, LLC ha tenido una oportunidad razonable, durante los sesenta (60) días después de haber recibido la notificación, para inspeccionar y averiguar la falla o el defecto antes de comenzar cualquier reparación.

#### Requisitos

##### Cobertizos de almacenamiento y Casitas de niños

Para dar validez a la garantía, es necesario mantener bien su unidad de Backyard Storage Solutions, LLC: cubrir con tejas el techo, pintar la cobertura con un producto 100% de acrílico y de látex para exteriores, usando dos manos de pintura o tinte, como mínimo, en el plazo de sesenta (60) días después de la construcción; masillar arriba de todas las puertas y todos los paneles de moldura horizontales y verticales; pintar y sellar todos los bordes dispuestos al exterior, los lados y las fachadas de la cobertura SmartSide™ y plano, incluyendo todos los muros exteriores y los lados y bordes de las puertas.

##### Belvederes, Pergolas y Edificios de Madera

Para dar validez a la garantía, es necesario mantener bien su unidad. Eso incluye tratar con un preservativo todos los superficies de cedro y de pino dispuestos al exterior, usando un preservativo para madera, un tinte de aceite semitransparente para exteriores, pintura acrílica de látex para exteriores, o un tinte acrílico de látex de un solo color, en el plazo de treinta (30) días después de construir el edificio, y luego como sea necesario.

Mantenga corta toda clase de vegetación cerca del edificio y asegúrese que la cobertura y la moldura no toquen ninguna obra de albañería o el cemento. El margen mínimo entre el suelo y la cobertura debe de ser media pulgada (1/2"), con un base de concreto; dos pulgadas y media (2 1/2") cuando se construye el edificio sobre un base de madera (usando un equipo de madera tratada). No se deben usar rociadores cerca de la unidad. En ningún caso será responsable Backyard Storage Solutions, LLC de daños especiales, incidentales, consiguientes o indirectos, ni de fallas causadas por sucesos, hechos u omisiones fuera de nuestro control; eso incluye, pero no está limitado a: el misuso; la construcción incorrecta; cuidado incorrecto (el cual causa, eventualmente, la putrefacción o la descomposición) y acciones de la naturaleza. Backyard Storage Solutions, LLC no será responsable de ningún gasto de instalación incurrido durante la construcción de la unidad. Esta garantía le da a Ud. ciertos derechos específicos que varían de estado a estado.

Para hacer una reclamación:

Para hacer una reclamación bajo esta garantía, llame al 1-888- 827-9056 o escriba una carta. Favor de tener la siguiente información al llamarnos, o incluirla al escribirnos:

1. El modelo y el tamaño del producto.
2. Una lista de las piezas por las cuales hace Ud. la reclamación.
3. Prueba de compra del producto, como se muestra en la factura original.
4. (Run code) escrita en la tarjeta amarilla de garantía incluida con el producto.

Envíe la información a:

Backyard Storage Solutions, LLC  
Attn: Customer Service  
1000 Ternes  
Monroe, MI 48162  
USA

**\*LAS CONDICIONES DE LA GARANTIA PUEDEN VARIAR FUERA DE ESTADOS UNIDOS**

**IMPORTANTE: Esta página es su certificado de garantía.  
Favor de llenar completamente y enviar la tarjeta de garantía para dar validez a la garantía.**

# FLOOR KIT INSTRUCTIONS FOR 10x8 and 10x16 BUILDINGS

ACTUAL SIZE • 120" WIDE x 96" DEEP (10X8)  
• 120" WIDE x 192" DEEP (10X16) #16630

1-800-437-0784

Parts Needed:

- A** 2 - 2x4x48" Bond Boards
- B** 2 - 2x4x72" Bond Boards
- C** 9 - 2x4x93" Floor Joist
- D** 2 - 48"x96"x5/8" Floor Panels
- E** 1 - 23-7/8"x96"x5/8" Floor Panels  
- 2" and 3" Nails

This instruction may be different from the one specified in Building instruction.

- Use for Premier Series Buildings only, cannot be used for a Marco Series Building or Premier Solar Shed

**NOTE: Part letters are not stamped on floor kits.**

## ASSEMBLY OF 120" x 96" FLOOR FRAME

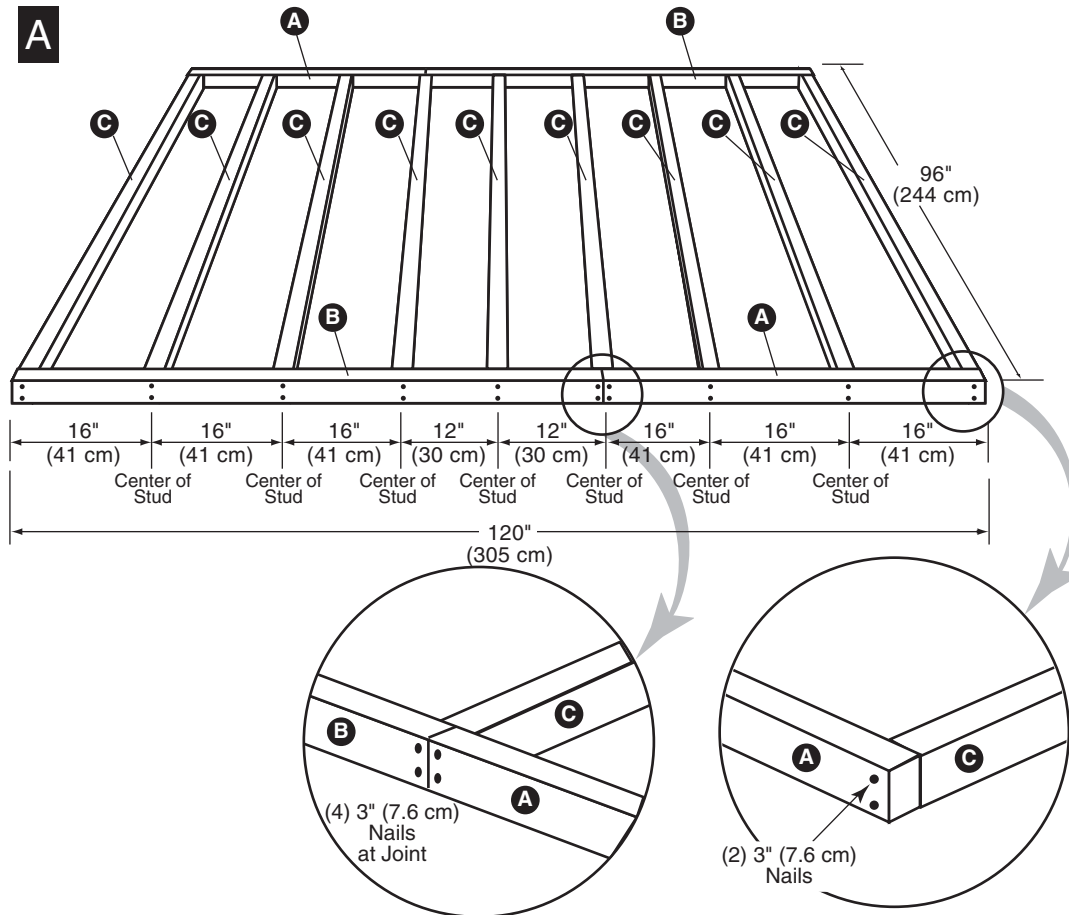

**A:** Position Bond Boards **A** & **B** and Floor Joists **C** as shown.

Using 3" nails, nail twice through each Bond Board **A** & **B** into each end of each Joist **C**, keeping pieces flush at top and ends, and maintain 16" and 12" spacing in middle as shown. Where **A** & **B** join together use 4-3" nails.

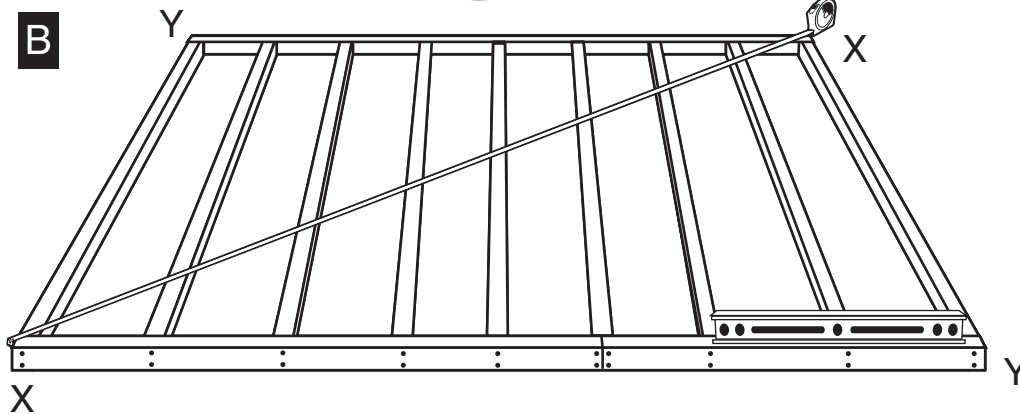

**B:** Completed Floor Frame should be positioned at building site, leveled, using shims between floor frame and ground before proceeding to Floor Panel Attachment.

Square frame by making corner-to-corner measurements (**X** to **X** and **Y** to **Y**) the same.

# 10x8 and 10x16 FLOOR KIT INSTRUCTIONS (CONTINUED)

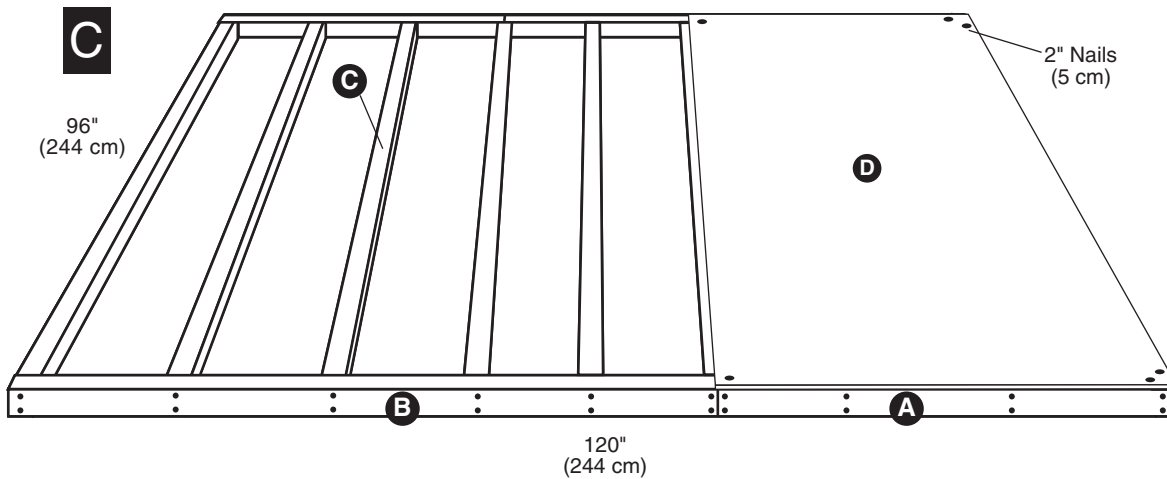

**C:** Position a 48 x 96" Floor Panel **D** flush to the outside edges of sides and back of Floor Frame. Secure panel with two 2" nails at outside corners and one 2" nail at other corners.

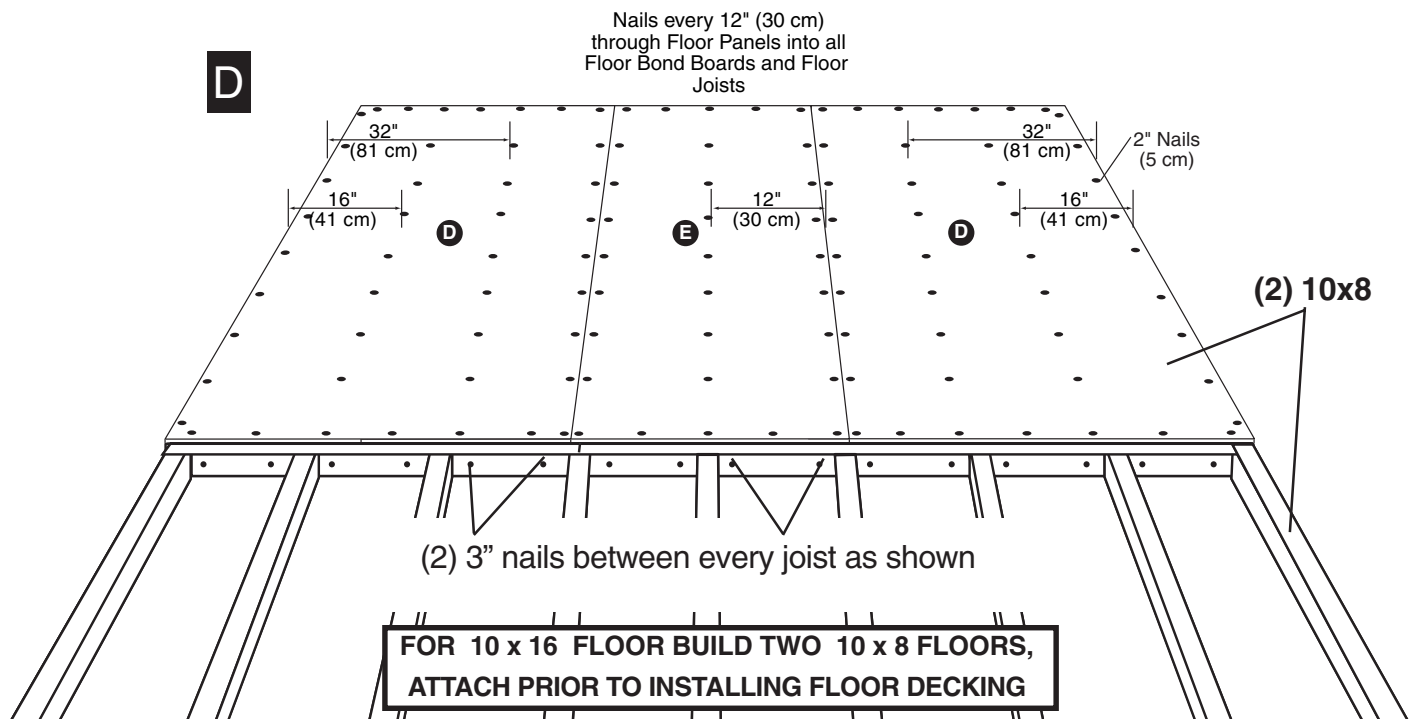

**D:** Position a 23-7/8" x 96" Floor Panel **E** flush against first panel and flush to edges of Floor Frame. Secure panel with one 2" nail at outside corners.

Position the other 48" x 96" Floor Panel **D** flush against second panel and flush to edges of Floor Frame. Secure panel with two 2" nails at outside corners and one 2" nail at each of other corners.

**Note:** Mark a line on the Floor Panel over the center of each Floor Joist using a pencil and a piece of lumber from the kit (or use a chalk line) to make nailing easier.

With Floor Panels flush to outside edges of Floor Frame, nail with 2" nails every 12" through Floor Panels into all Floor Bond Boards and Floor Joists.

Your Floor is now complete. Check to be sure it is properly positioned and leveled to ground before beginning assembly of your Wooden Storage Building.