



**ELEVATE
GRILL**

**USER MANUAL
For Model: ELVGRL-X**

**IMPORTANT
DANGER & WARNINGS**

You Must Read This User Manual Before Operating Your Gas Grill
Keep This Manual For Future Reference

© 2015 PointElevate, Inc.
POINTELEVATE.COM

DANGER & WARNINGS

This manual contains important information necessary for proper assembly and safe use of the appliance. Read and follow all warnings and instructions before assembling and using the appliance. Follow all warning and instructions when using the appliance.

DANGER

If you smell gas:

1. Shut off gas to the grill by turning the control to the off position.
2. Extinguish any open flames.
3. Open lid.
4. If odor continues, keep away from the appliance and immediately call your gas supplier or your fire department.

Failure to follow these instructions could result in fire, explosion or burn hazard, which could cause property damage, personal injury or death.

DANGER

1. Never operate this appliance unattended.
2. Never operate this appliance within 10 ft. (3m) of any structure, combustable material or other gas cylinder.
3. Never operate this appliance within 25 ft. (7.5m) of any flammable liquids.
4. If a fire should occur, keep away from the appliance and immediately call your fire department. Do not attempt to extinguish an oil or grease fire with water.

Failure to follow these instructions could result in fire, explosion or burn hazard, which could cause property damage, personal injury or death.

If there are local codes that apply to the portable gas grills, you must conform with local codes or, in the absence of local codes, with the National Fuel Gas Code, ANSI Z223.1/NFPA 54, Storage and Handling of Liquefied Petroleum Gases, ANSI/HFPA 58; or Natural Gas and Propane Installation Code, CSA B149.1; Propane Storage and Handling, CSA B149.2.

The LP gas supply cylinder must be constructed and marked in accordance with the specifications for LP gas cylinders, U.S. Department of Transportation (DOT) or the Standard for Cylinders, Spheres and Tubes for the Transportation of Dangerous Goods, CAN/CSA-B339.

California Proposition 65 Warning: The burning of gas cooking fuel generates some by-products which are on the list of substances known by the State of California to cause cancer and reproductive harm. California law requires businesses to warn customers of potential exposure to such substances. To minimize exposure to these substances always operate this unit according to this grill manual, ensuring you provide good ventilation when cooking with gas.



DANGER & WARNINGS

You must read this owner's manual before operating your gas grill for the first time.

GENERAL INSTRUCTIONS

- Follow all-leak check procedures carefully listed in this manual prior to barbecue operation. Do this even if a dealer assembled the barbecue.
- Improper assembly may be dangerous. Carefully follow the assembly instructions.
- After a period of storage and/or non-use, carefully inspect the grill for gas leaks or damages.
- Do not operate the grill if there is a gas-leak present.
- Do not leave the appliance unattended. Keep children and pets away from the appliance at all times.
- Check and clean burners/venturi tubes for insects and insect nests. A clogged tube can lead to a fire beneath the appliance.
- Do not use a flame to check for gas leaks.
- Combustible materials should never be 24 inches of the grill.
- Children should never use the grill. Parts of the grill get extremely hot and unsafe to touch.
- Exercise reasonable care when operating your grill. It will be hot during cooking and cooling periods.
- Grill should be operated stationary.
- Grill should never be moved while under operation. Follow the safety guidelines in this manual for proper transportation of this product.
- Should the burner go out while in operation for any reason besides propane cylinder being empty, turn off flow of gas and wait five (5) minutes.
- Do not place charcoal or any material in your grill. This is a gas barbecue grill.
- Never lean over an open grill while it is operating.
- Never place hands or fingers on the edge of the cooking surface while grill is operating or cooling.
- Certain parts of the grill will get hot under operation. Exercise reasonable care while grill is operating.
- Do not attempt to enlarge valve orifice or burner ports.
- Grill should be thoroughly cleaned on a regular basis.
- The regulator supplied should only be used with the Elevate Grill.
- This is a propane gas grill; not a natural gas grill. Using natural gas with this grill will void your warranty.
- Use heat-resistant barbecue gloves or mitts when operating the barbecue grill.
- Keep grill away from electrical cord, any heated surface and combustible byproducts when in operation.
- This grill is intended to be used outdoor only.
- Do not operate this grill in a building, garage or any other enclosed area.
- This grill is not intended to be installed in or on a boat. This appliance is not intended to be installed in or on recreational vehicles.
- Maintain proper clearance from combustible construction, the minimum clearances must be defined (recommend 24 inches) from such construction to the sides and back of the appliance, and that the appliance shall not be located used under overhead unprotected combustible construction.
- Do not operate or attempt to start this grill unless all parts are in place and in the proper area assigned in this manual.
- Do not attempt to remove the regulator or any gas fitting while your barbecue grill is in operation.

- Do not tamper, alter or modify any parts of this grill. In doing so may cause explosion resulting in property damage and serious bodily harm, which may result in severe injuries or death.
- Do not use this grill as a campfire or heater.
- This grill is not intended for commercial use.
- Do not store a spare gas cylinder in or near the appliance.
- If the instructions are not followed exactly, a fire causing death or serious injury may occur.

KNOWING YOUR GRILL

PARTS LIST:

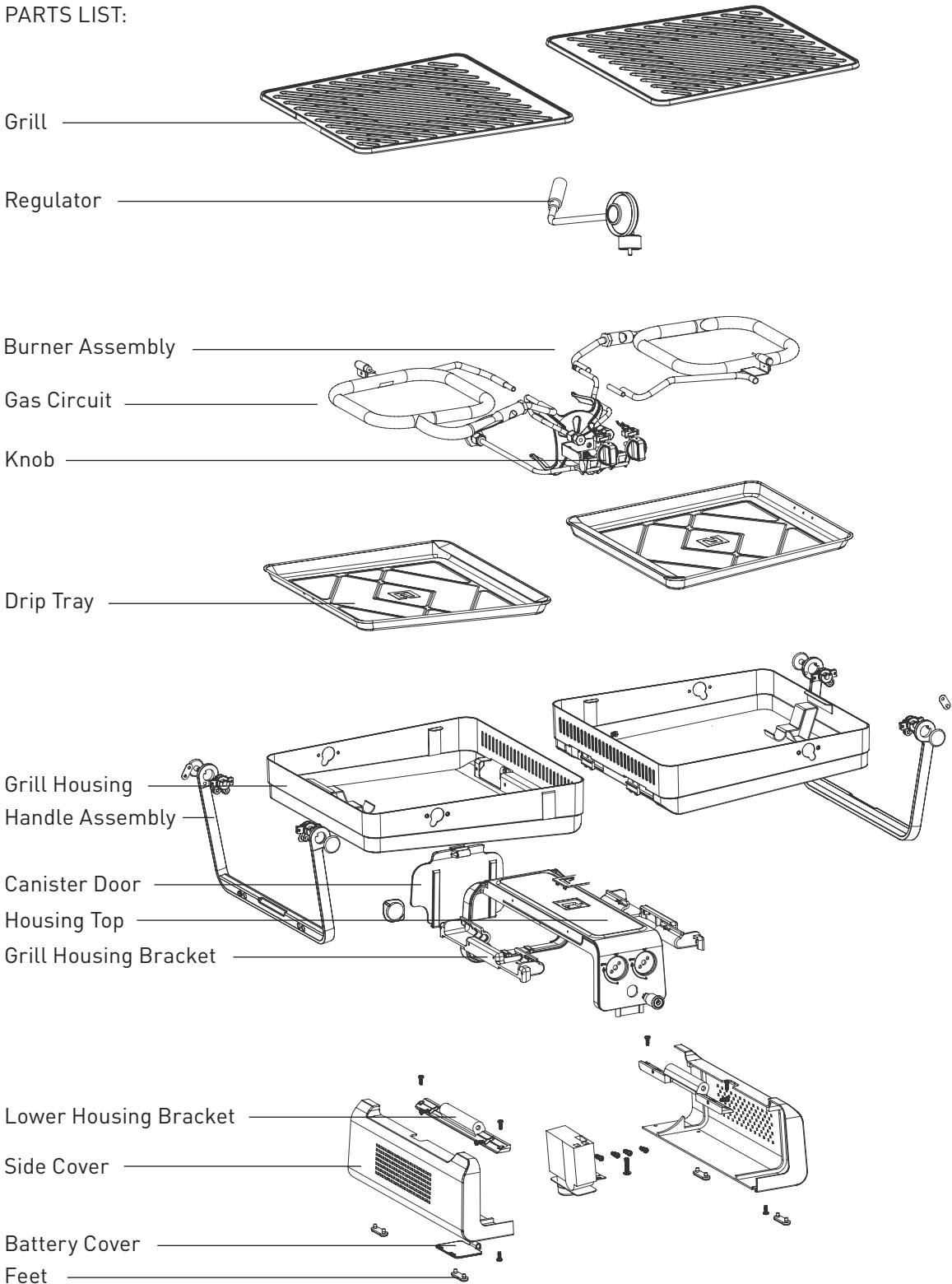

MODEL #: ELVGRL-X

BATTERY INSTALLATION

1. Locate Battery Compartment on the bottom of the base.

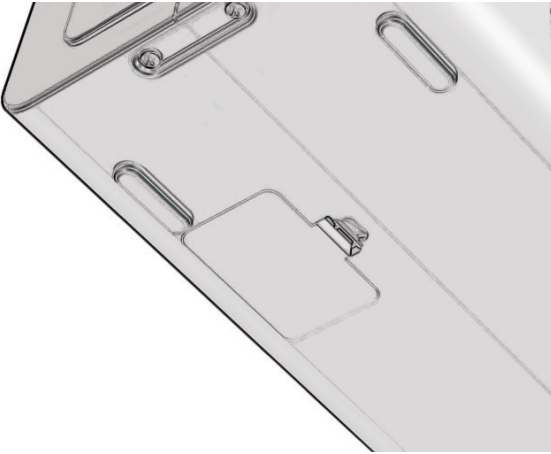

4. Insert battery negative first.

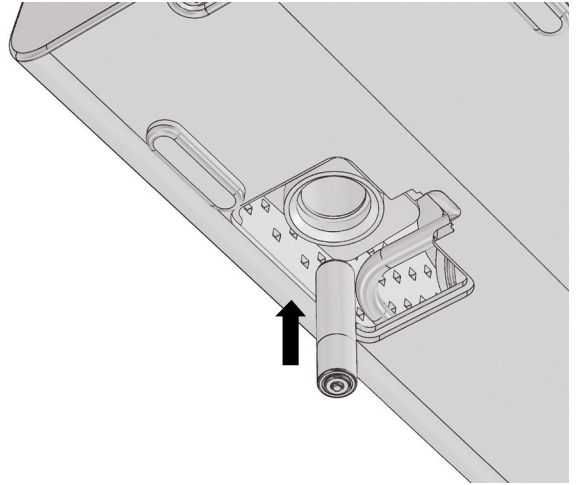

2. Remove battery compartment cover.

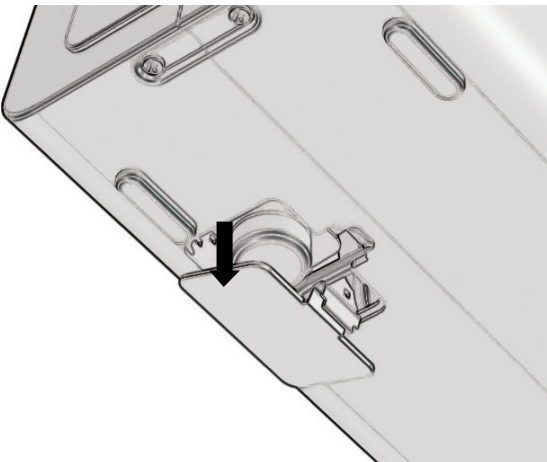

5. Replace and tighten battery cap.

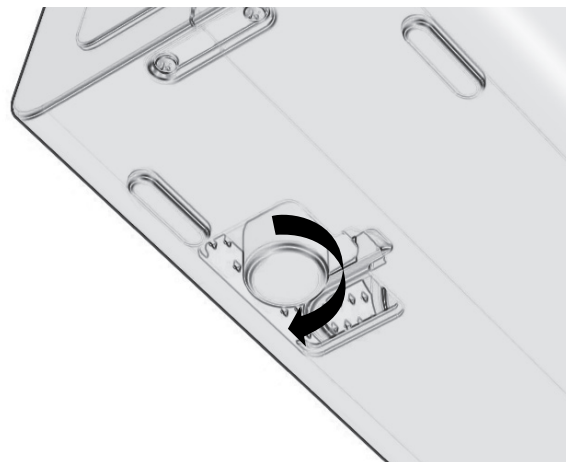

3. Rotate counter-clockwise to loosen battery cap.

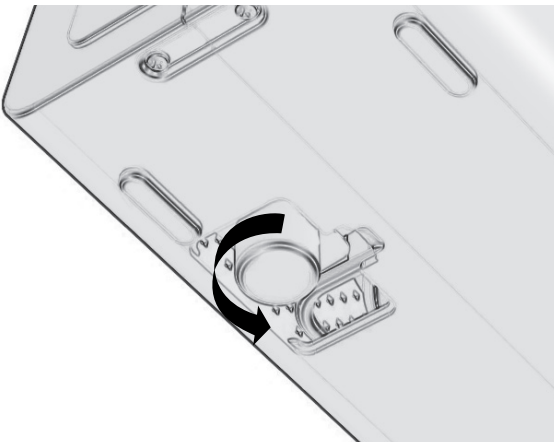

6. Replace battery compartment cover.

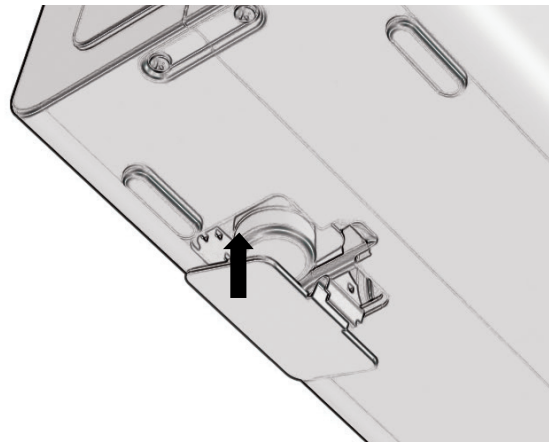

SETTING UP YOUR GRILL FOR THE FIRST TIME

1. Place grill on steady flat surface with the base level to the surface.



4. Insert the grate indentation under the grill lip and then lower gently until grate rests evenly in the grill.

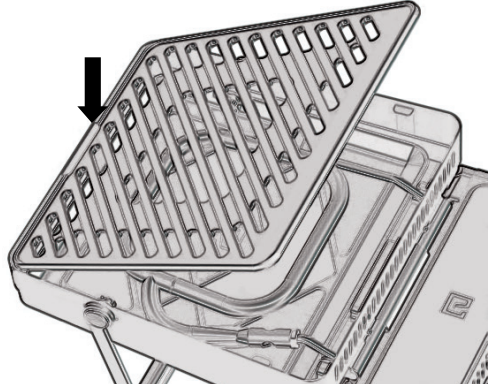

2. Separate carrying handles and rotate downwards until the handles engage the locking position.

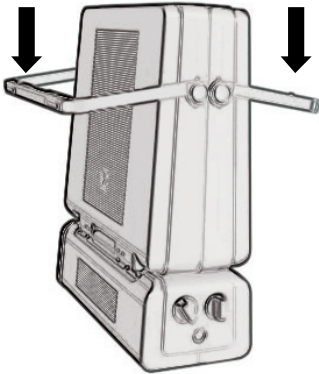

5. Repeat the same process for second adjacent side.

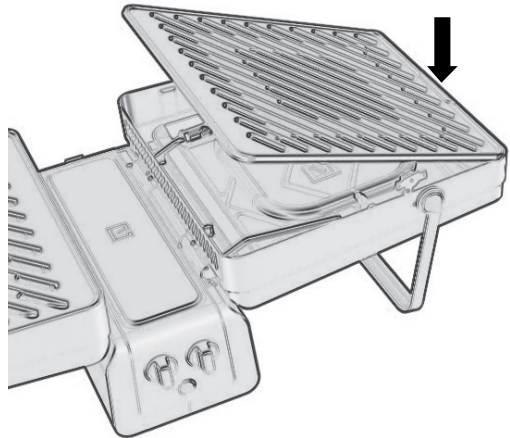

3. Unfold grill and lower each side until handle/legs rest upon the flat surface.

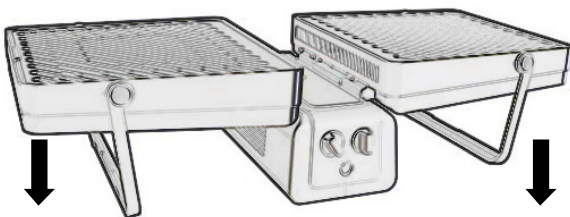

LEAK TESTING

After a period of nonuse, we recommend that you perform the following maintenance procedures for your safety.

- Inspect the burner for correct flame pattern. Clean if necessary, following the procedures outlined in the “Maintenance” section of this manual.
- Check all gas fittings for leaks.

WARNING

You should check for gas leaks every time you disconnect and reconnect a gas fitting.

NOTE: All factory-made connections have been thoroughly checked for gas leaks. The burners have been flame tested. As a safety precaution, you should recheck all fittings for leaks before using your Elevate grill. Shipping and handling may have loosened or damaged a gas fitting.

WARNING

Perform these leak checks even if your grill was dealer or store-assembled.

You will need soap, water solution and a rag to conduct a leak test. To perform leak checks, make sure the burner is in the OFF position. **DO NOT IGNITE BURNER WHILE LEAK CHECKING.** Check for leaks by wetting the connection with the soap and water solution. Watch for bubbles. If bubbles form or if a bubble grows, there is a leak. If there is a leak, do not operate grill and use a different propane cylinder and recheck for leaks later. If a leak persists after retightening the propane cylinder, contact our customer service team located on the back of this manual.

WARNING

If you see, smell or hear the hiss of escaping gas from the propane cylinder:

- 1. Move away from the propane cylinder.**
- 2. Do not attempt to correct the problem yourself**
- 3. Call your fire department.**

ATTACHING REGULATOR & PROPANE CYLINDER (16.4 CANISTER)

Note: Use only propane cylinders with the capacity of 16.4 oz./465 g (1.02 lbs.). You can find these tanks available in most sporting and hardware stores.

Statement: The LP gas supply cylinder must be constructed and marked in accordance with the specifications for LP gas cylinders, U.S. Department of Transportation (DOT) or the Standard for Cylinders, Spheres and Tubes for the Transportation of Dangerous Goods, CAN/CSA-B339.

Statement: The pressure regulator and regulator assembly supplied with the appliance must be used. Replacement pressure regulator must be those specified by the manufacturer.

Statement: The cylinder supply system must be arranged for vapor withdrawal.

1. Remove plastic cap on propane cylinder if applicable.



2. Screw propane bottle into regulator hand tight by rotating clock-wise. (Fig. 01)



FIG. 01

3. Attach regulator to the inlet valve located behind the base of the grill (Fig. 02).

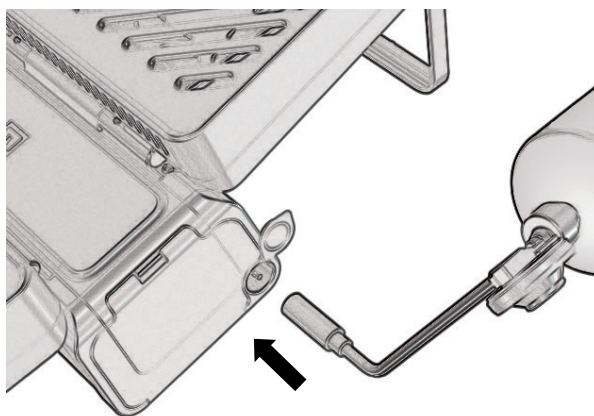

FIG. 02

4. Rotate the locking mechanism clock-wise hand tight. (Fig. 03)

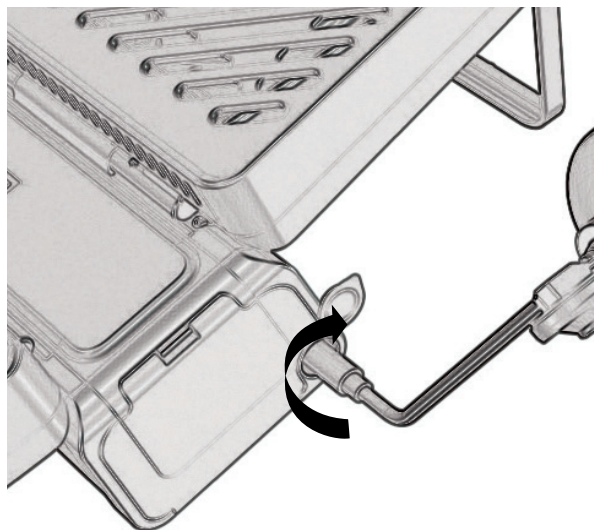

FIG. 03

5. Grill with regulator and propane cylinder properly assembled. (Fig. 04)

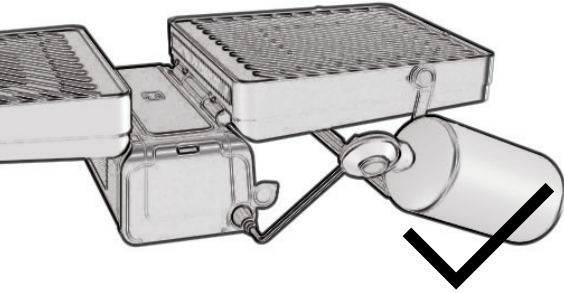

FIG. 04

6. Never operate grill with propane cylinder in an inverted position. (Fig. 05)

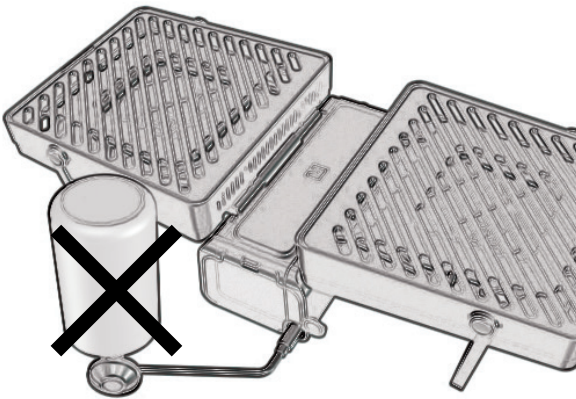

FIG. 05

⚠ WARNING

If there is a leak at connection, remove the propane cylinder. Do not operate grill and use a different propane cylinder.

⚠ WARNING

Do not use a wrench to tighten the propane cylinder to the regulator. Using a wrench could damage the regulator coupling and cause a leak.

STARTING THE GRILL

Note: Always check for gas leaks before starting your grill. Refer to page 8, Attaching Regulator & Propane Cylinder.

1. Ensure ON/OFF button is OFF and volume control knobs are in the OFF position.

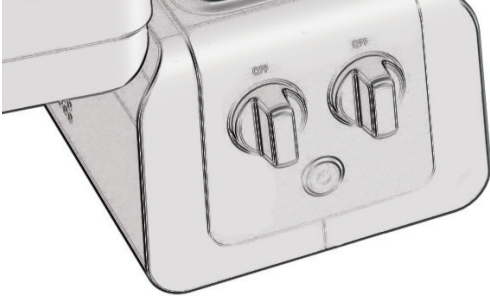

2. Press ON/OFF button to the ON position.

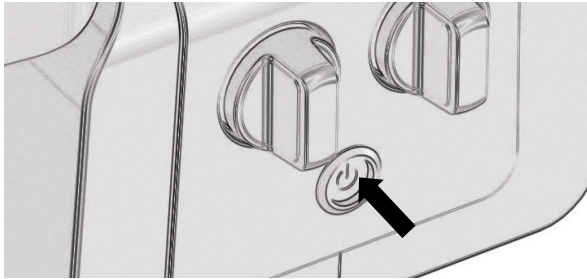

3. Press and hold volume control knob and turn to ignite position.



4. Continue holding until burner is lit.

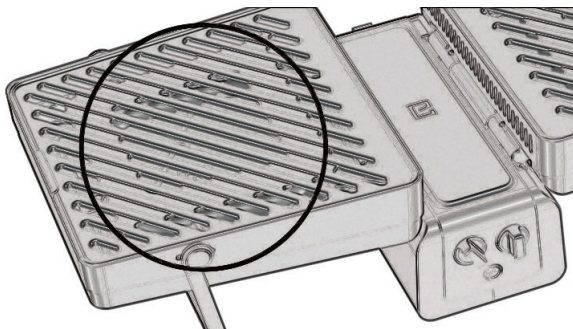

5. Release volume control button.

6. Adjust flame to desired cooking level.

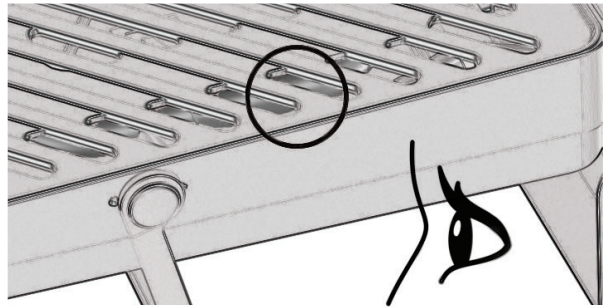

7. A good flame should be blue with minimal yellow tip. Some yellow tips on flames are acceptable as long as no carbon or soot deposits appear.

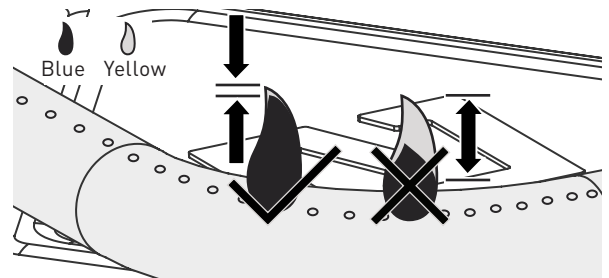

8. If desired, repeat steps for adjacent burner.

⚠ WARNING

If ignition does not occur in 5 to 10 seconds, turn the volume control knob off. Turn ON/OFF button to OFF. Wait 5 minutes for excess gas to dissipate. Then repeat steps 1 through 6.

⚠ WARNING

If there is no ignition "clicking", refer to page 5, Battery Installation.

⚠ WARNING

Never leave grill unattended when hot or in use.

TURNING OFF YOUR GRILL

1. Return volume control knobs to OFF position.

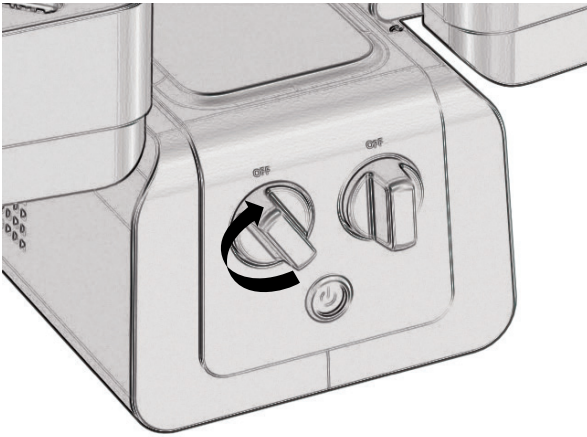

2. Press ON/OFF button to OFF position.

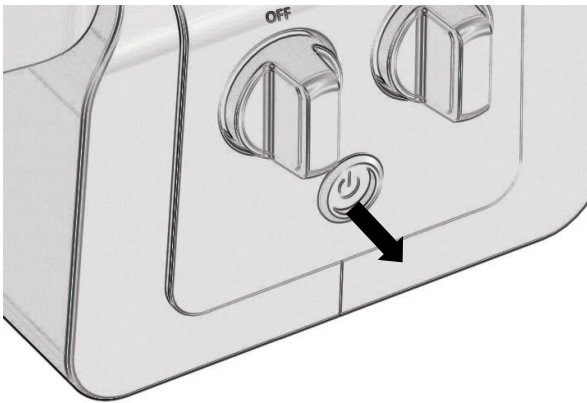

3. Check to ensure burners are no longer lit.

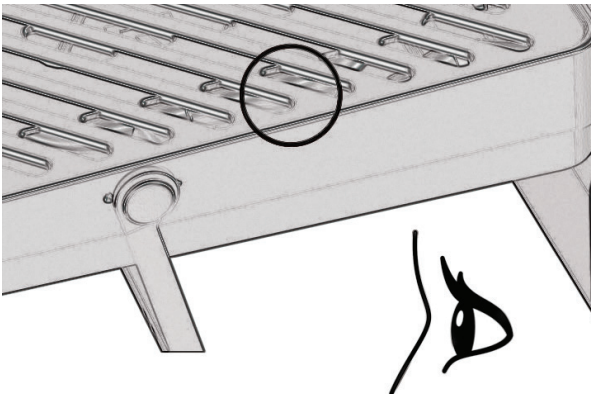

4. Wait for grill to completely cool before closing.

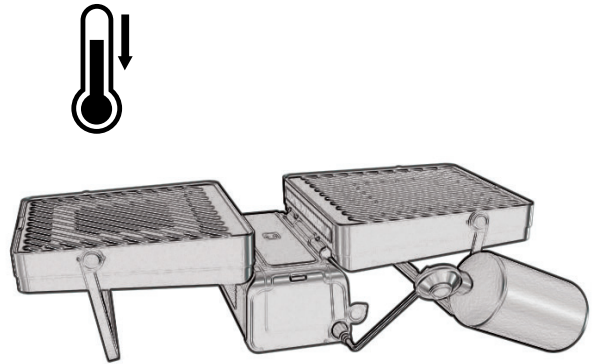

5. Fold grill to upright position and raise handles until joined and locked.



⚠ CAUTION

Grilling surfaces remain HOT after flames have been extinguished.

REMOVING REGULATOR & PROPANE CYLINDER

1. Unscrew locking mechanism counter clockwise until loose.

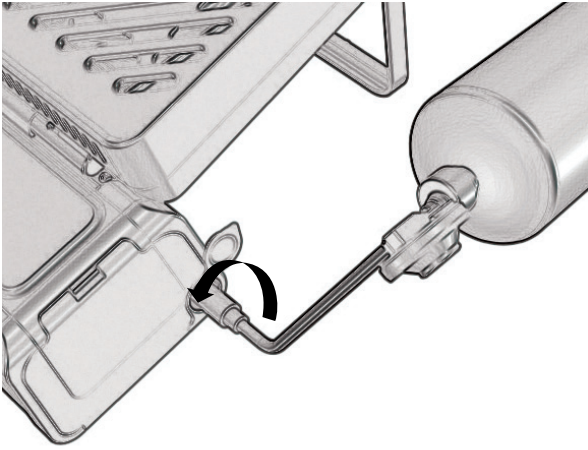

2. Remove regulator from valve inlet.

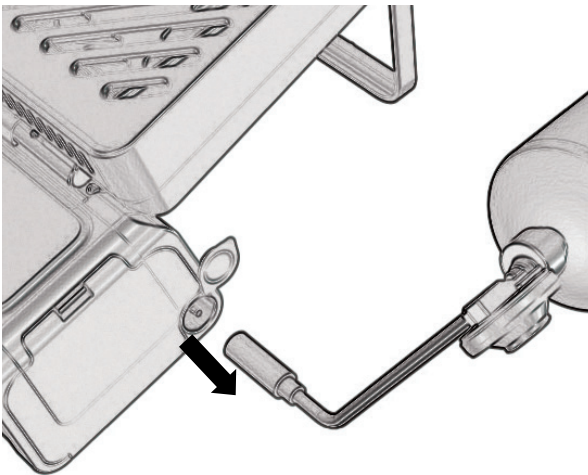

3. Remove propane from regulator.

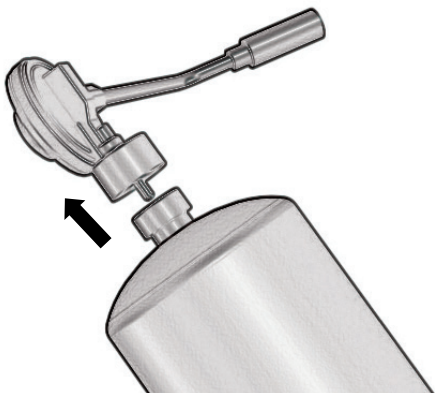

⚠ WARNING

Do not use wrench to loosen the propane cylinder from the regulator. Using a wrench could damage the regulator and propane cylinder.

⚠ WARNING

Always detach propane cylinder after each use. Use proper storing techniques in accordance to manufacturers guidelines.

⚠ CAUTION

Dispose propane cylinder appropriately in accordance to your state laws and guidelines.

⚠ CAUTION

The cylinder must be disconnected when the appliance is not in use.

STORING PROPANE CYLINDER IN BASE

1. Press down on latch and move cover in a downward motion.

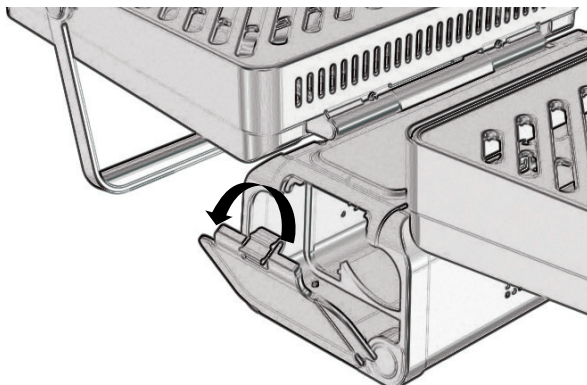

2. Insert propane cylinder bottom first and slide canister until fully recessed.

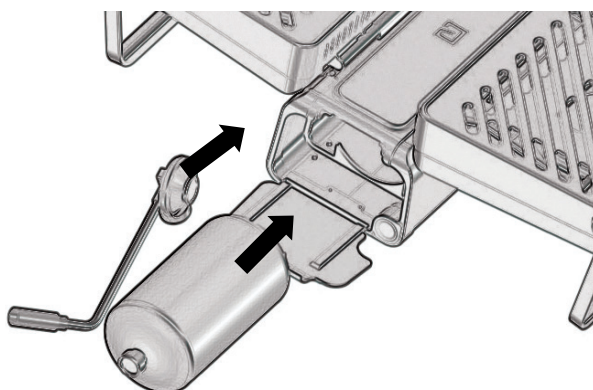

3. Close cover door until locked into position.

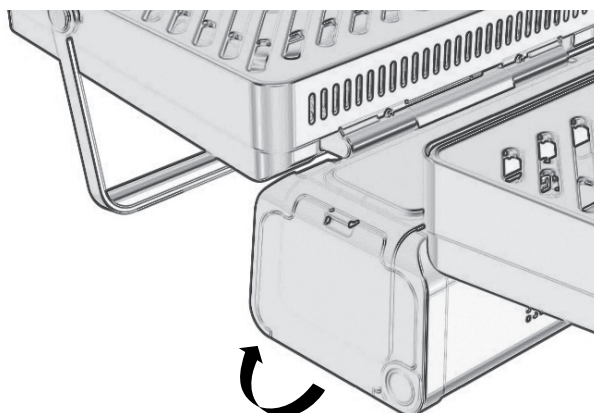

⚠ WARNING

Store propane cylinder in accordance to manufacturer guidelines.

⚠ DANGER

Never store propane cylinder near high heat, open flames, pilot lights direct sunlight and other ignition sources.

⚠ DANGER

Do not store propane cylinders where temperatures will exceed 120° F (Fahrenheit).

USING GRATE REMOVAL TOOL

1. Use the grate removal tool supplied and insert into one of the slits nearest the center of the grill. (Fig. 06)

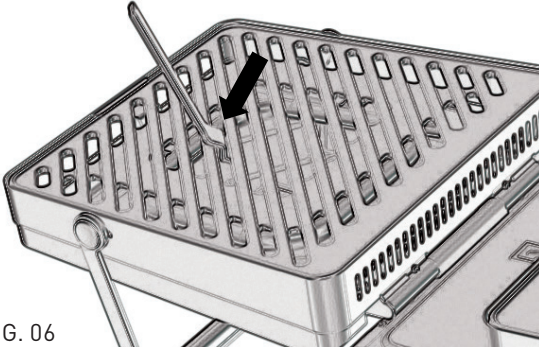

FIG. 06

2. Stabilize tool and lift slightly. (Fig. 07)

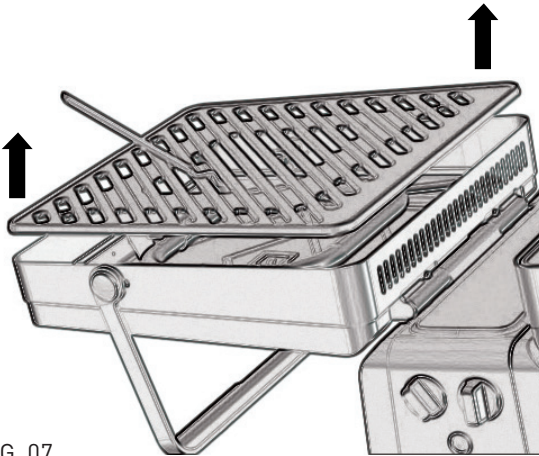

FIG. 07

3. Pull outwards to remove grate from the grill. (Fig. 08)

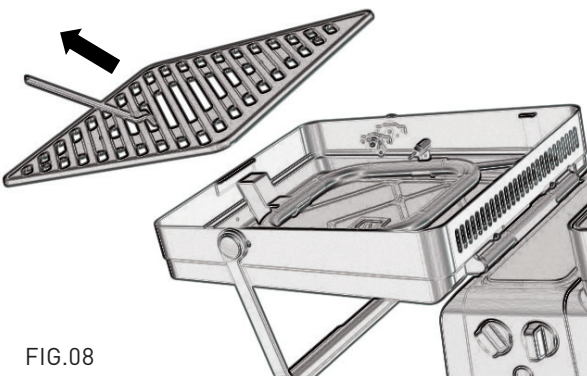

FIG. 08

⚠ WARNING

Do not attempt to lift grates when it is HOT. Make sure grill is cool before attempting to use grate removal tool.

REMOVING GREASE TRAY

Note: Grate must be removed to access grease tray. Refer to page 14, Using Grate Removal Tool.

1. Lift burners gently to the maximum position. (Fig. 09)

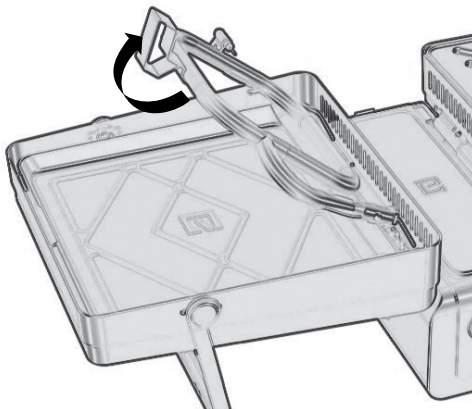

FIG. 09

2. Lift grease tray using the handles at an angle from the open area. (Fig. 10)

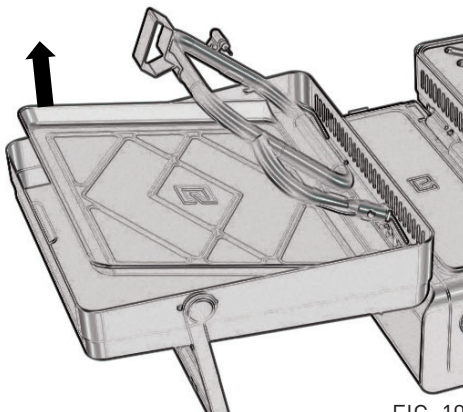

FIG. 10

3. Remove grease tray at an angle pulling outwards from the clearance provided. (Fig. 11)

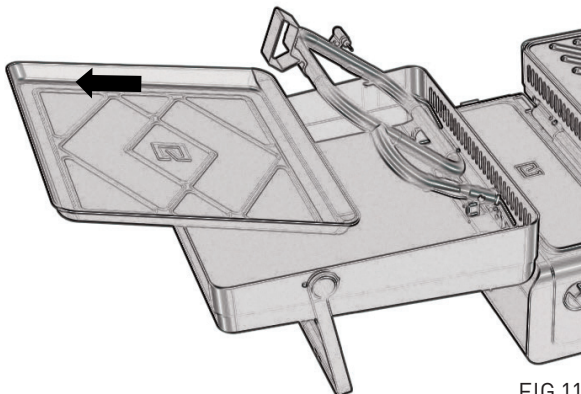

FIG.11

⚠ WARNING

Do not attempt to remove grease tray when HOT.

⚠ CAUTION

Grease tray has built-in reservoir for excess debris when transporting. Recommended to clean after each use to avoid grease fire from build-up.

CLEANING & MAINTAINING YOUR GRILL

Note: Do not use oven cleaner, abrasive cleansers, cleaners that contain citrus products or abrasive cleaning pads on any part of the grill.

GRATES

1. Make sure grates are cool.
2. Wipe grates clean with soft cloth moistened with a mixture of vegetable oil and salt.
3. Do not use abrasives materials to clean grates.

Maintenance: Before every use ensure grates are free of any residue. If there is residue, turn burners to high for 10 to 20 minutes and use a wire brush to remove any food debris or grease.

⚠ WARNING
Only attempt to clean grates when cool.

GREASE TRAY

1. Make sure grease tray is cool
2. Wipe grease tray clean with soft cloth and mild detergent. Do not use abrasives.
3. Grease tray is dishwasher safe.

Maintenance: Clean grease tray after each use to prevent residue from accumulating. Grease tray is dish washer safe.

BURNER EXTERIOR

1. Brush any debris off of burner tubes.
2. Wash inside of cooking box with soapy water and a water rinse.

Maintenance: Remove any debris off burners before each use using a tooth brush or soft bristle brush.

⚠ DANGER
Do not attempt to clean burners when grill is operating. Doing so may result in fire that can cause serious bodily injury or death and damage to property.

⚠ WARNING
Attempt to clean only when burners are cool.

BURNER TUBES

Check the orifice to ensure there is no blockage. Use a needle to clear any debris. Be extremely careful not to enlarge the hole or break off the needle.

Maintenance: Annually check inside the burner tubes for spider/insect nests.

CLEARING INSECT/SPIDER NESTS

1. Check burners at the venturi tube using a flashlight to inspect for spider/insect nests.
2. If clogged, use a wire (e.g. straightened out coat hanger) to remove any blockage.

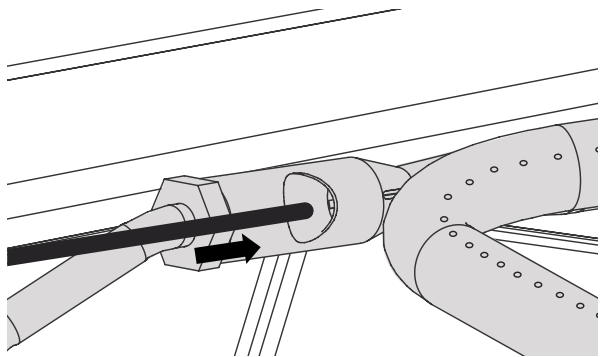

3. Attach burners back to the orifice properly (Fig. 12)

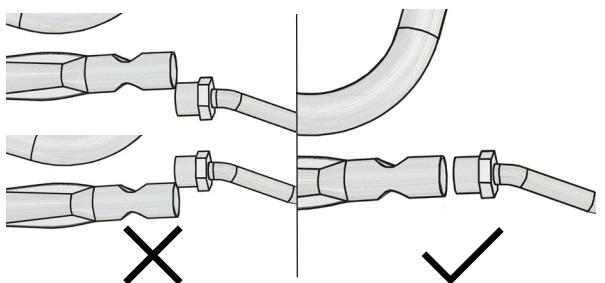
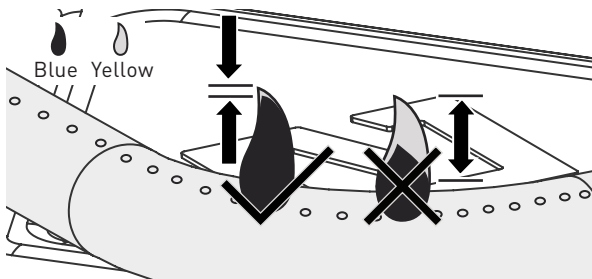

FIG. 12

Maintenance: Annually check inside the burner tubes for spider/insect nests.

HOW TO VISUALLY CHECKING BURNER FLAMES

A good flame should be blue with minimal yellow tip. Some yellow tips on flames are acceptable as long as no carbon or soot deposits appear.



⚠ WARNING

Keep appliance area clear and free from combustible materials, gasoline and other flammable vapors and liquids.

⚠ DANGER

Do not obstruct the flow of combustion and ventilation air.

LIST OF OPTIONAL ACCESSORIES

- Aluminum Griddle Plate (Model #: ELVAGP)
- Aluminum Cooking Grates (Model #: ELVACG)
- Ceramic Pizza Stone (Model #: ELVCPS)

LIMITED WARRANTY

PointElevate ("Seller") and the person or entity that acquires these goods from Seller ("Purchaser") hereby fully agrees to the following terms and conditions of the sale: Shipping fees are the responsibility of the Purchaser whether freight prepaid or freight collect. Seller assumes no responsibility for the goods sold to the Purchaser once the goods have left the Seller's premises, including but not limited to, late delivery by the moving carrier, or for events caused by any difficulty carrier incurs in attempting to fit the goods into the Purchaser's place of business or residence due to size of the goods or otherwise Purchaser assumes all responsibility for delivery, payment of freight, access, measurement, installation, hook-up, wiring, moving and storage of the goods. The transportation of all goods is subject to the terms and conditions which the moving carrier imposes on Purchaser including, but not limited to, additional charges imposed per flight of stairs, and/or additional charges resulting from the carrier's inability to safely and/or adequately use the building elevator to lift the goods to an upper level. Any claim for damages incurred during the shipment by the carrier of the goods are insured and handled directly with the carrier. Any damages due to manufacture defects will be handled directly with PointElevate, subject to the limited warranty.

All sales are final, and unless authorized in writing by the Seller, Purchaser may not return the goods, under any circumstance. If Purchaser refuses to accept the goods, under any circumstance, the Purchaser is liable for the return and cost of freight both ways, and if seller does take the goods, there may be a restocking fee that of 20% of the purchase price of the goods in addition to the freight. Purchaser must notify Seller of non-conforming goods within seven (7) days of delivery, after which time all goods are deemed accepted. If an order has been placed and production started, cancellation cost of your order will be 20% or the purchase price.

The limited warranty does not cover damage due to such things as accident, misuse, abuse, mishandling, neglect, acts of God, fires, earthquakes, floods, high winds, government, war, riot or labor issues defined as strikes, lockouts, delay of carrier, unauthorized repair, or any other beyond the control of the Seller whether similar or dissimilar to the foregoing. Seller is not responsible for any damages caused by the Purchaser misusing, mishandling or abusing the intended use of the goods. Limited warranty applies only inside the Continental U.S. (Alaska, Puerto Rico and Hawaii not included).

Seller is not responsible for incidental or consequential damages and there are no warranties, expressed or implied, which extend beyond the limited warranty described above. The implied warranties of merchantability and of fitness for a particular purpose are hereby expressly disclaimed. Some states do not allow the exclusion of incidental or consequential damages, or a waiver of the implied warranties of fitness and/or merchantability, so the above limitations may not apply to you. This warranty gives you specific legal rights and you may have other rights, which vary from state to state.

LENGTH OF WARRANTY

One (1) year guaranteed from manufacture defects

Three (3) years limited parts warranty covering the burners.

Recycling: Most of the materials used to manufacture this grill are recyclable. Please dispose of those materials properly in accordance to your local state laws. Improper disposing of this grill can be harmful to the environment.

If you have questions relating to the use, warranty, return, claims and replacement, please call:

Phone: 877-551-0484 (Monday to Friday 8:30am-5:30pm PST)

Email us at info@pointelevate.com (24 hour)

For more information, you can visit us at:

www.pointelevate.com



FOR OUTDOOR USE ONLY

If you have any questions about assembly, operations, warranty or service, Contact PointElevate at:

PointElevate, Inc.
16770 E Johnson Dr. City of Industry, CA 91745
Phone: 877-551-0484
Email: info@pointelevate.com