

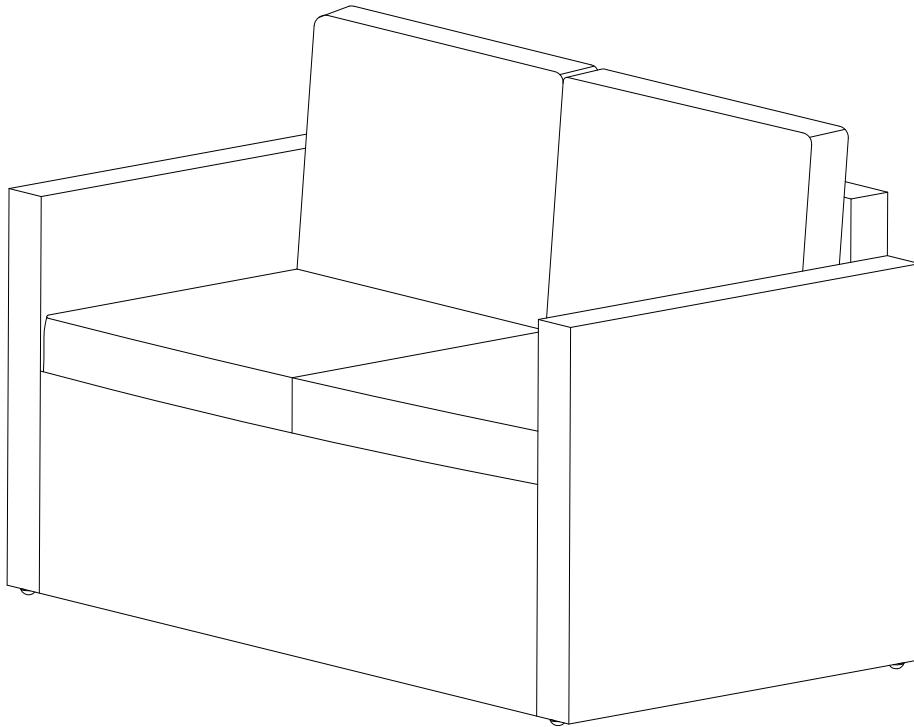





Palm Harbor Outdoor
Wicker Love Seat



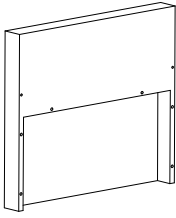
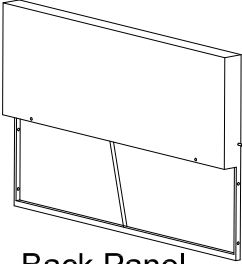
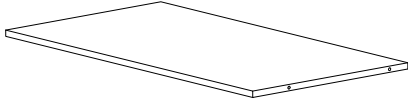

CO7106-BR

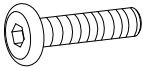
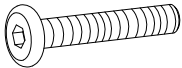
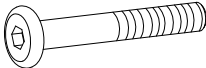

PART LIST

 <p>Arm Panel</p>		 <p>Back Panel</p>		 <p>Seat Panel</p>	
A	2pcs	B	1pc	C	1pc
 <p>Lower Front Panel</p>		 <p>Seat Cushion</p>		 <p>Back Cushion</p>	
D	1pc	M	2pcs	N	2pcs

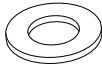
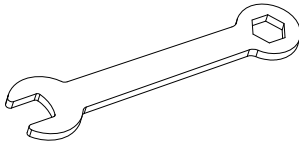
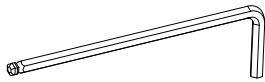
HARDWARE LIST

 <p>Short Bolt(M6*30mm)</p>		 <p>Medium Bolt(M6*40mm)</p>		 <p>Long Bolt(M6*50mm)</p>	
E	2pcs	F	4pcs	G	10pcs
 <p>Nut(M6mm)</p>		 <p>Washer(M6mm)</p>		 <p>Wrench(M6mm)</p>	
H	14pcs	I	30pcs	J	1pc
 <p>Allen Key(M6mm)</p>		 <p>Adjustable Leveler</p>			
K	1pc	L	4pcs		

Step 1. Lay Arm Panel (A) down on a flat surface. Attach Back Panel(B) to Arm Panel(A) using the Medium Bolt(F), Washer(I), Nut(H), Wrench (J) & Allen Key (K).

NOTE: Do not fully tighten bolt until all bolts are in place.

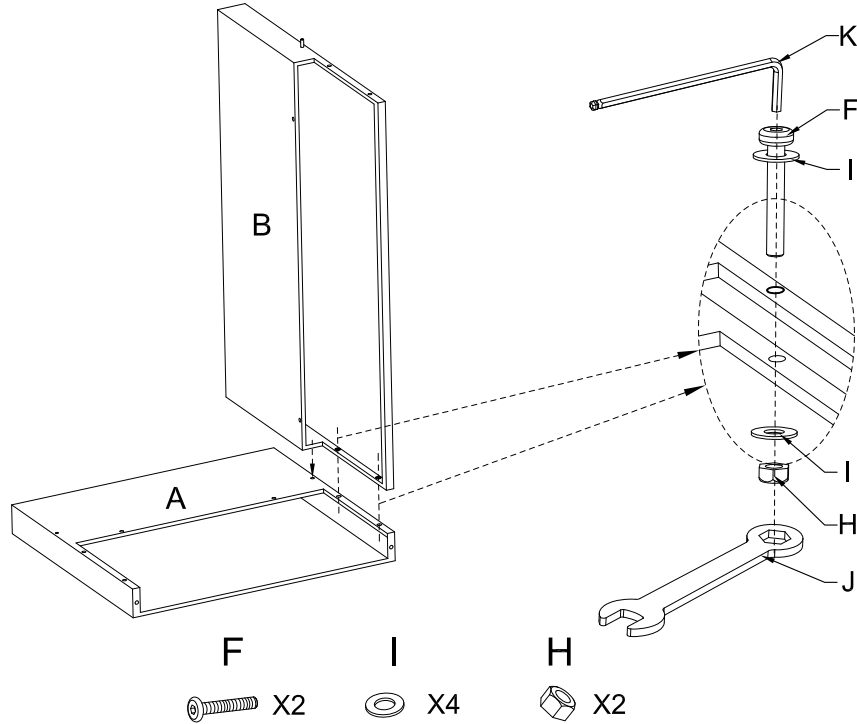

Step 2. Attach Seat Panel(C) to Arm Panel(A) and Back Panel (B) using the Long Bolt(G) Washer(I), Nut(H), Wrench (J) & Allen Key (K).

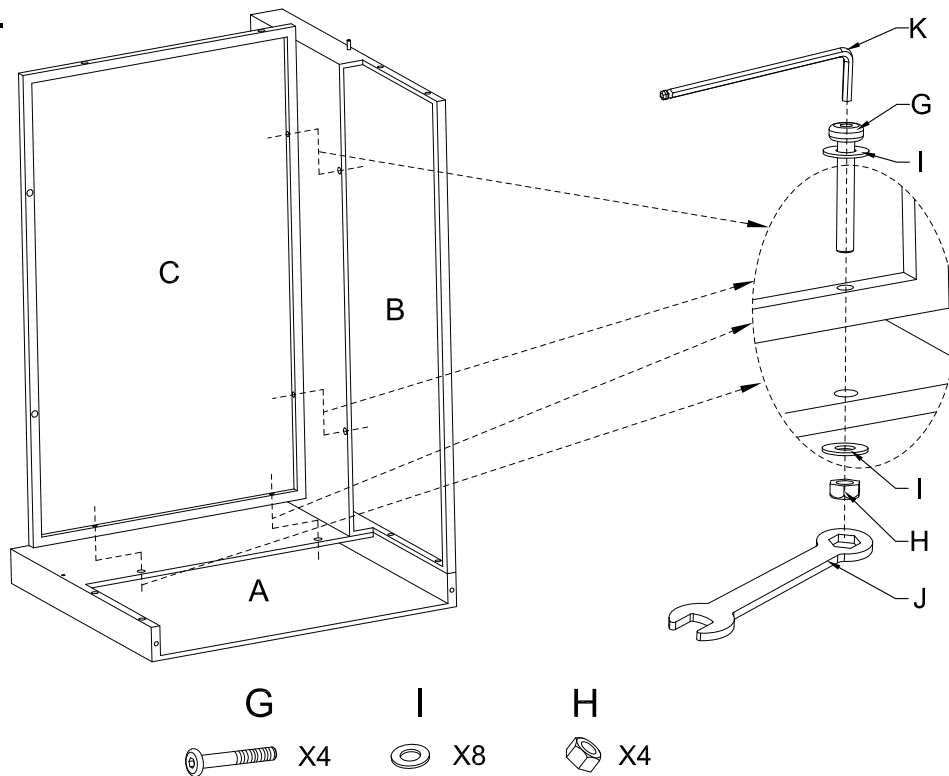

Step 3. Attach Lower Front Panel (D) to Arm Panel (A) using the Long Bolt(G), Washer (I), Nut(H), Allen Key (K) & Wrench (J), to Seat Panel (C) using Short Bolt (E), Washer (I) & Allen Key (K).

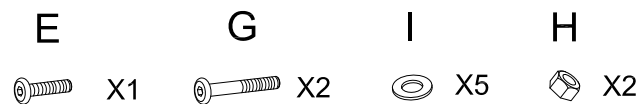
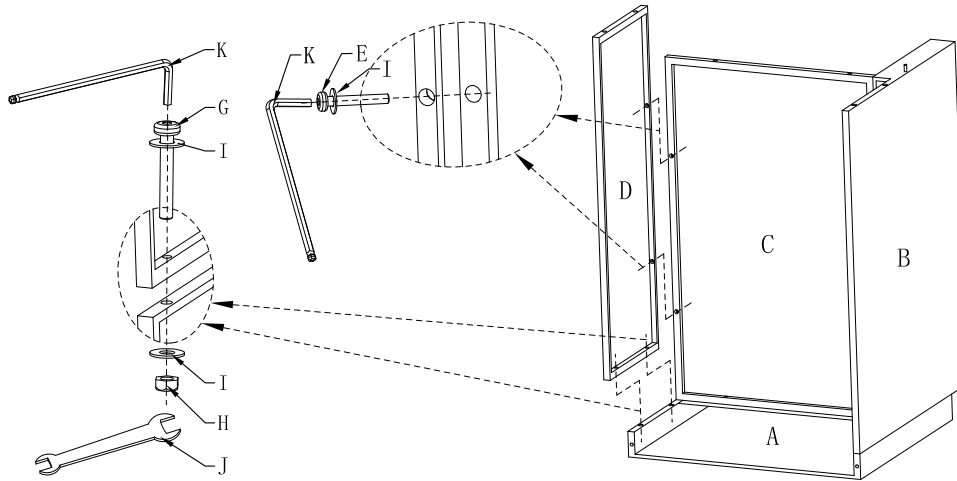

Step 4. Attach Arm Panel (A) to the Assembled Part (A,B,C&D) using Bolt (F), Bolt (G), Washers (I), Nut (H), Wrench (J) and Allen Key (K) as shown.

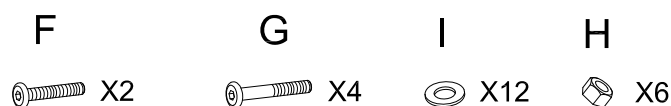
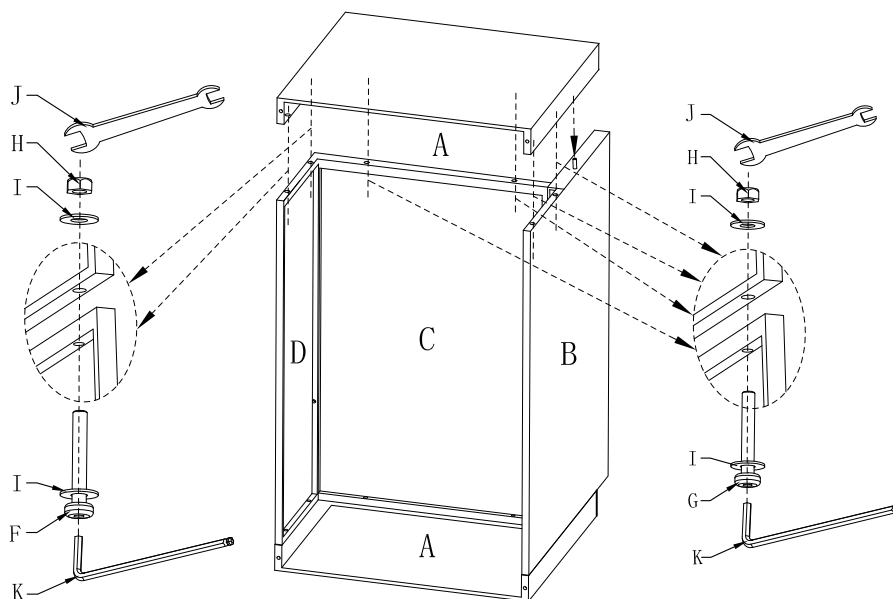

Step 5. Screw the Adjustable Levelers (L) into the pre-drilled holes, to the desired position, on the bottom of the chair.

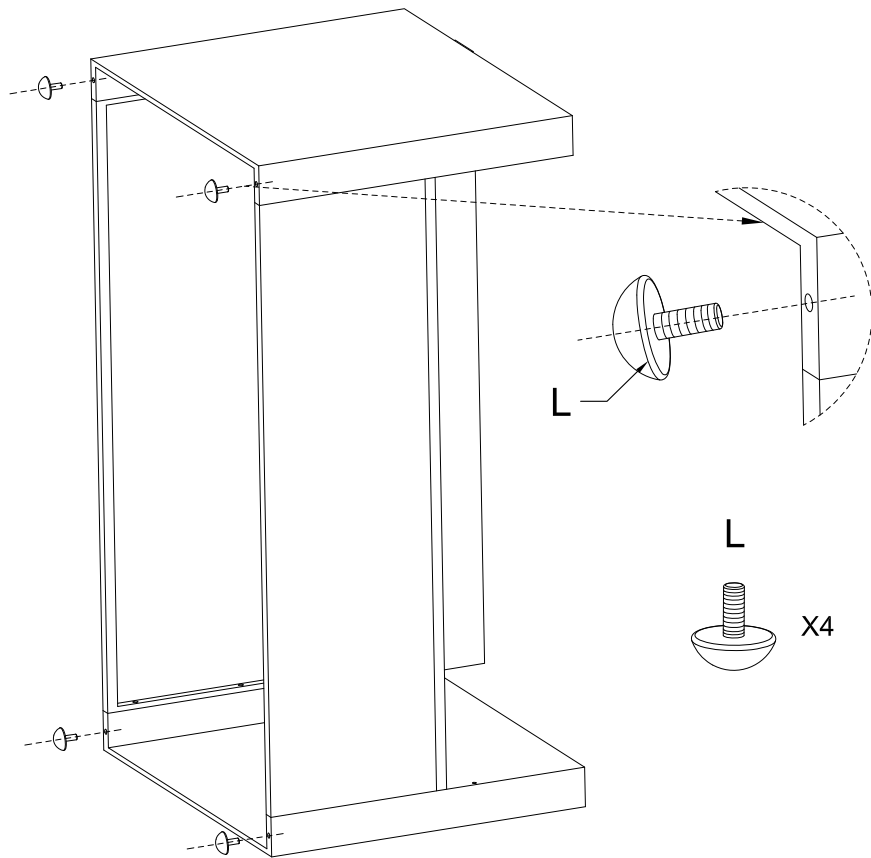

Step 6. Turn the assembled chair upright on a flat surface, add the Seat and Back Cushions.

