



Best Barns USA Assembly Book

Revised November 22, 2013



the Denver-R

12' x 16'

Manufactured by Reynolds Building Systems, Inc.

205 Arlington Drive

Greenville, PA 16125

724-646-3775

This manual is copyrighted. Under the copyright laws, this manual may not be copied, in whole or in part, without consent from Reynolds Building Systems, Inc. © Copyright 2011

IMPORTANT INFORMATION ABOUT YOUR SHED KIT

Thank you for purchasing our shed kit. These instructions will construct a 12'x16' building. **If you received two books, use the one with the latest revision date.**

Read the instructions before starting the assembly of the building. If you have any questions about assembling the kit, call 800-245-1577. Business hours (8:00-5:00 ET) Monday thru Friday. After business hours call 724-866-HELP (4357) or email to help@barnkits.com.

The material that is included in our kit is listed on the back page. The optional floor package, if purchased, will be supplied by a local lumber supplier.

Our kit does not include the shingles, the quantity needed is listed on the back page. The siding is primed. You will need to apply a finish coat using latex acrylic paint.

Some of the framing lumber was used in the shipping pallet. Unpack the material from the pallets, then unscrew the bottom runners from the 2x4s. The bit for the screws is packed in the hardware bag. This material will be used for wall bracing.

Most buildings are installed on a wood floor and the siding was designed to extend over the wood flooring. If the foundation is a concrete floor cut the siding flush with the bottom of the wall plate to prevent the concrete from contacting the siding.

Stacking the boards, according to size, will make them easier to find when needed. Some boards have colored ends. All the wall studs have black ends, stack these boards together. **Do Not** discard any material until your building is complete.

Before you begin construction, be sure to study this assembly manual. Also, obtain a building permit and check all pertinent building code regulations.

Thank you for your purchase.

Bill & Linda Rinella, owners

To identify which edge we want you to use, we will refer to the edge as either the 'LAP' Edge or the Tongue Edge. Nail siding with 8d galv. nails, spaced 12" apart.

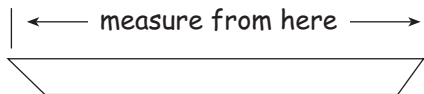
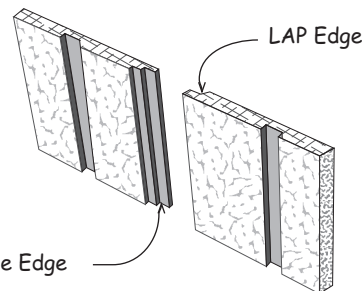

When measurements are given for a board length or width, it is from the longest side.

Tool List

- | | |
|---|--|
| <input type="checkbox"/> Hammer & Hand Saw | <input type="checkbox"/> Power Drill/screwdriver |
| <input type="checkbox"/> Framing Square & Level | <input type="checkbox"/> Measuring Tape |
| <input type="checkbox"/> Power Circular Saw | <input type="checkbox"/> 2-8' Step Ladders |

Always wear safety glasses when cutting or nailing!

Constructing Details for Deluxe Floor System

Deluxe floors include 4x4 runners, standard floors do not

Foundation size is 12'-0" x 16'-0". Check local building codes in your area, the construction may have to change. For a concrete slab, install sill sealer as a moisture barrier between the concrete and the wall plates. Foam sill sealer can be purchased at home centers in rolls 3-1/2" or wider.

1. Cut (2) two 2x4 joist headers to 16' - 0". Layout for 16" on center joist spacing. 'X' marks where floor joist will be placed.

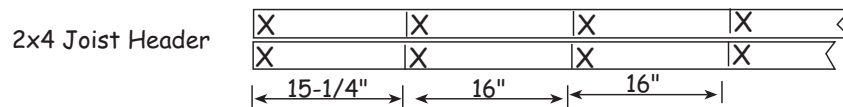

2. Cut 2x4-12' floor joist to 11'-9". *Treated lumber may be thicker than 1-1/2". Take this into account when cutting the length of floor joists. Shorten joist measurements if necessary to obtain 12'-0" building width.*

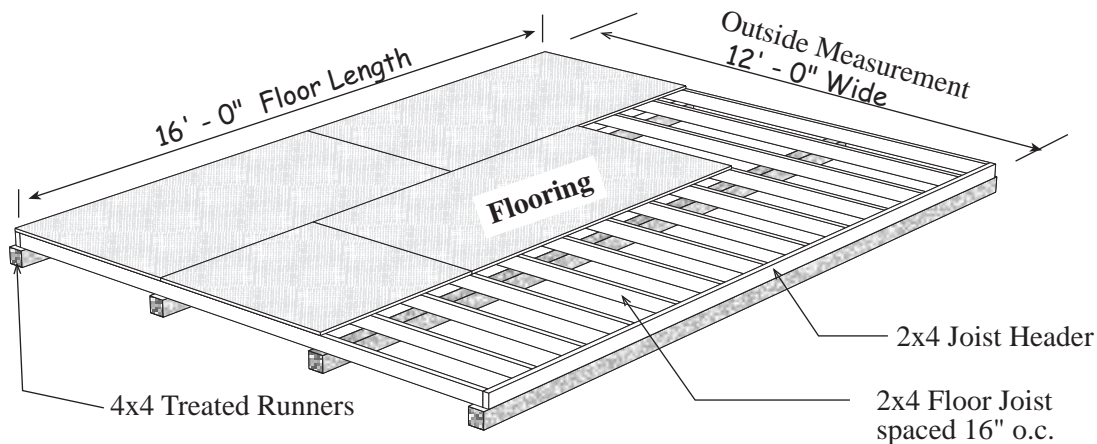

It is important that the floor be level and square. Square the floor as follows: before nailing the flooring, measure the floor diagonally (corner to corner). Then measure the opposite corners. These measurements will be the same if the floor is square.

Material Description	12' x 16' shed
2x4 Joist Headers	2 pcs. 16'
2x4 Floor Joist	13 pcs. 12'
4x4 Treated Runners	8 pcs. 8'
Flooring 5/8" or 3/4"	6 pcs. 4x8
Screw Floor Nails	2 lb. 8d
Galv. Box Nails	2 lb. 16d

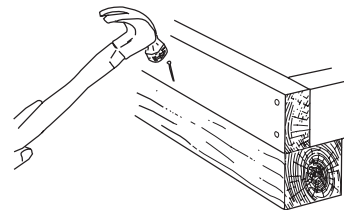

Nail 2x4 joist headers and floor joist to 4x4.

Step 1 Assemble Trusses

 Temporarily screw 2x4 blocks to the floor to insure that all the trusses are assembled the same. Short 2x4s, *that may have an angle on one end*, are supplied in the kit.

1. Butt (2) two 72" long 2x4s together and secure them by nailing a 3-1/2" x 42-3/4" long plywood gusset across the top where they butt together. Use glue and 6d common nails. Install the gusset with the center line lined up where the 2x4 meet.

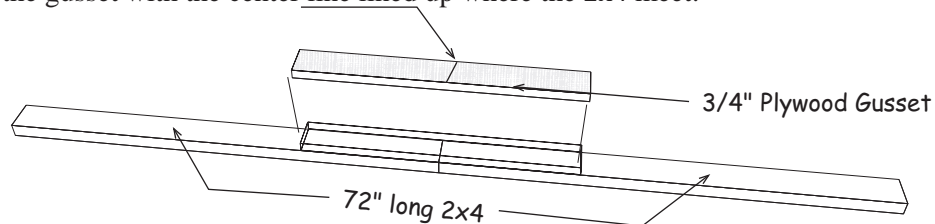

2. Repeat to assemble another Gable Plate Assembly
3. Position a Gable Plate Assembly on the floor. Use 2x4 blocks to hold the 2x4 plate straight.
4. Position (2) two truss halves (*2x4s connected with a metal plate*) with the short legs against the 2x4 Gable Plate Assembly. **DO NOT** attach the Gable Plate Assembly to the truss. It is temporarily used to help hold the 2x4 truss parts in place and will be used in a later step.
5. Secure 2x4 blocks around the perimeter of truss to hold truss parts in place.

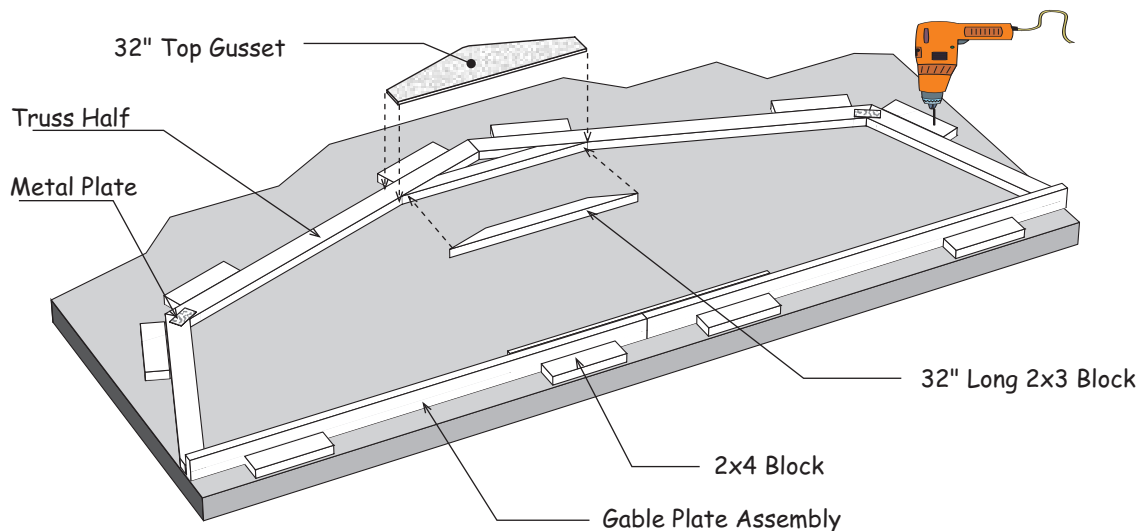

6. Nail the 2x3-32" board where the trusses meet at the top. Secure with a 32" wood gusset. Apply wood glue between the gusset and 2x4s. Nail gusset using (20) twenty 6d common nails.
7. Turn the truss over and install a gusset to the other side of the truss.
8. Repeat to assemble (6) six more trusses.

Step 2 Assemble Roof Gables

1. Position (2) two truss halves together and secure the top with a 1"x4" barbed metal plate. Nail a 32" long 2x3 board at the ridge to help secure the top.
2. Cut a 42-3/4" long 2x4 to length and install in the center of the gable. Toenail the bottom to the plywood gusset with 10d sinkers. Secure the top with a barbed metal plate.
3. Butt (2) two 40-3/4" long 2x4s against the wood gusset. Secure the bottom to the 2x4 plate by nailing through the plate with (2) two 10d sinkers. Secure the top with barbed plates.
4. Install (2) two 30-3/4" long 2x4s the same way.

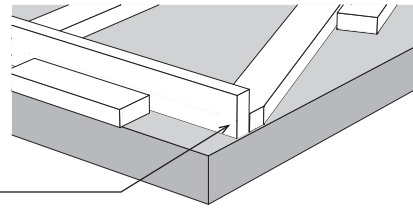

5. Nail truss leg to 12' Gable Plate with 10d sinkers.

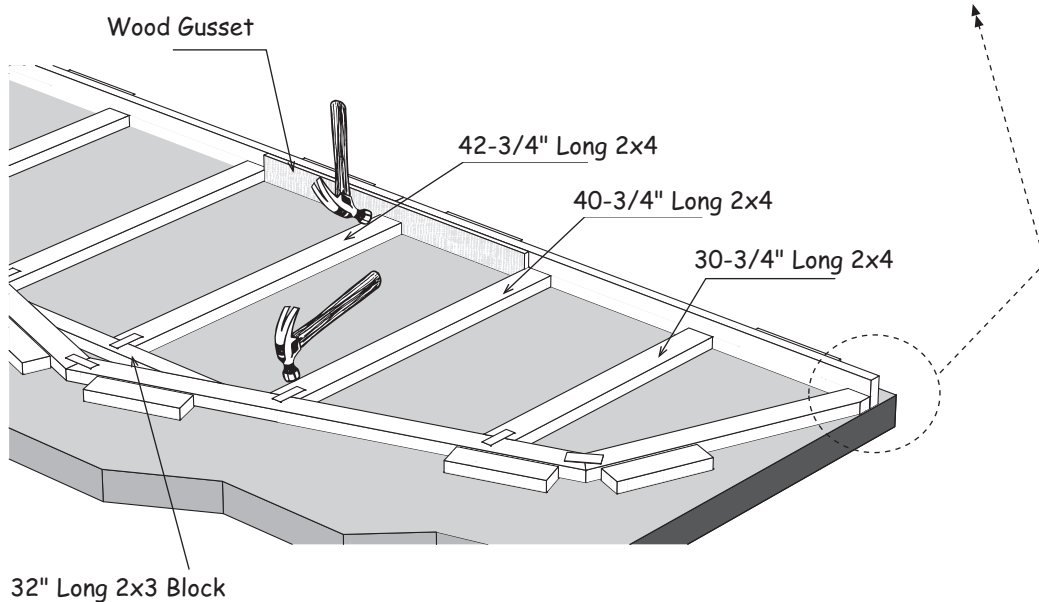

6. Repeat steps to assemble the front roof gable.

Step 3 Apply Siding and Trim to Roof Gables

1. Remove 2x4 blocks and turn the gable frame over.
2. Install pre-cut siding on rear gable. Bottom of siding extends 3/4" below the gable plate. Use 6d galv. nails spaced 12" apart.
3. Install (2) two 61" long 1x4 gable trim flush with the top edge of the gable. Install the ends with blue marks together. Install trim with 8d galv. nails.

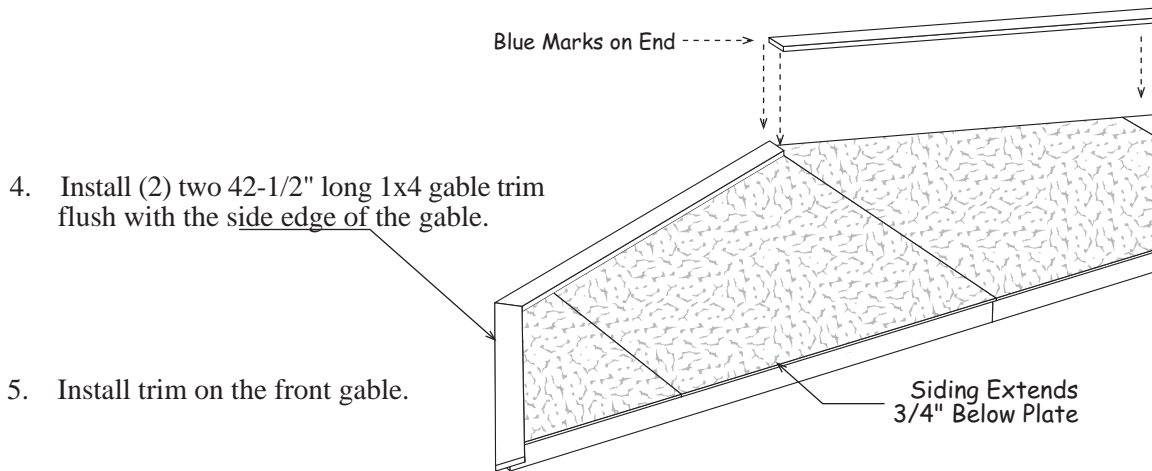

Step 4 Assemble Door Header & Bottom Wall Plate

Assemble door header using (2) two 75" long 2x6 boards and a 75" OSB filler panel. Apply wood glue between OSB and boards. Nail header together with 10d sinkers. Use (12) twelve nails on each side.

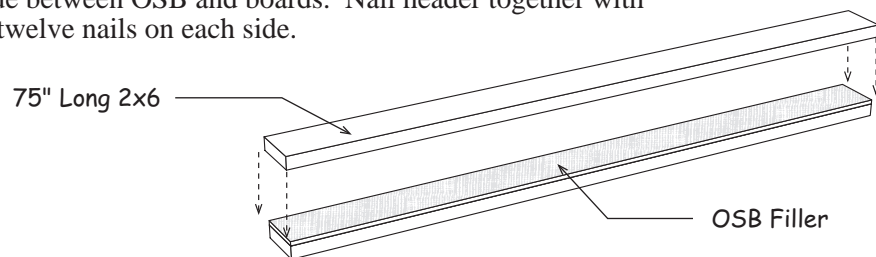

Butt (2) two 68-1/2" boards together. Center a 2x4-6' board (used as door spacer) on top and screw the boards together using (4) four 2-1/2" wood screws. Mark stud spacing as shown below.

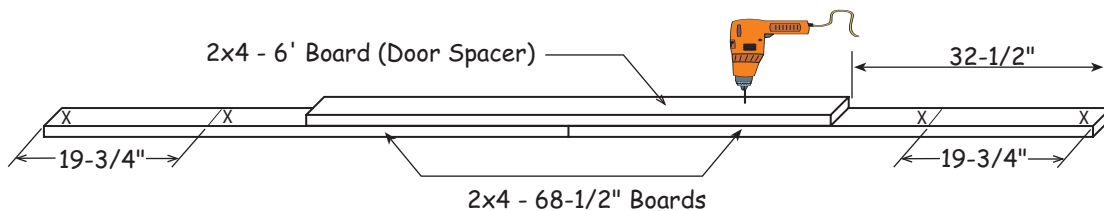

Step 5 Assemble Front Wall (doors centered)

1. Gather the material listed below to assemble the door wall.
2. Install (4) four 80-1/4" wall studs over the 'X' marks.
3. Install the wall studs with the door jacks on each side of the door spacer.
4. Install door header on the door jacks.

Material List	
2	68-1/2" Wall Plates
4	80-1/4" Wall Studs
2	80-1/4" Wall Studs w/ door jacks attached
1	Door Header from Step 4
1	Bottom Plate from Step 4

* Check measurements. They should be the same or the door opening will not be square!

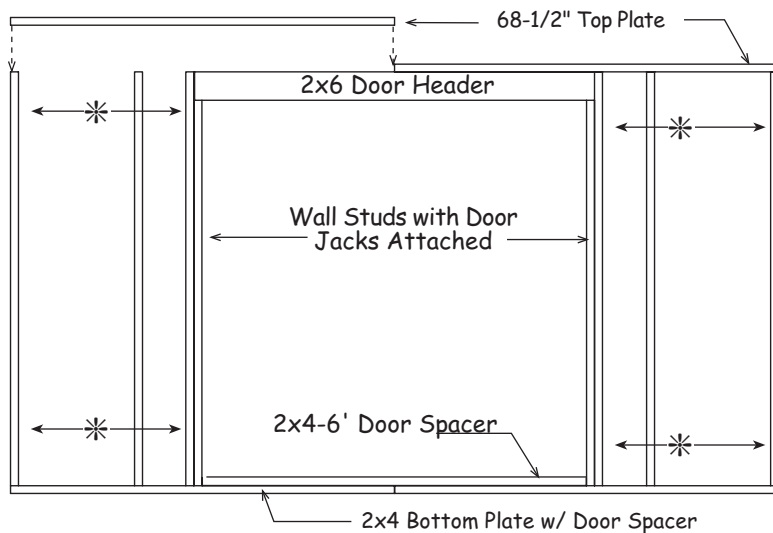

5. Locate a 12" siding panel that has a 'LAP' edge. Position the 'cut' edge flush with the left side of the door opening. **Do not** nail the 'LAP' edge until the other siding is applied.
6. Select the 24" wide siding panel, with the 'tongue edge', and install this siding panel at the left end of the wall frame as shown below.
7. Install (2) two 7-3/4" pre-cut siding panels over the door opening, flush with the top plate.
8. Install a 12-3/4" siding panel with the 'cut' edge flush with the side of the door opening.
9. Install the last siding panel. It will extend 3-1/2" beyond the 2x4 wall frame.

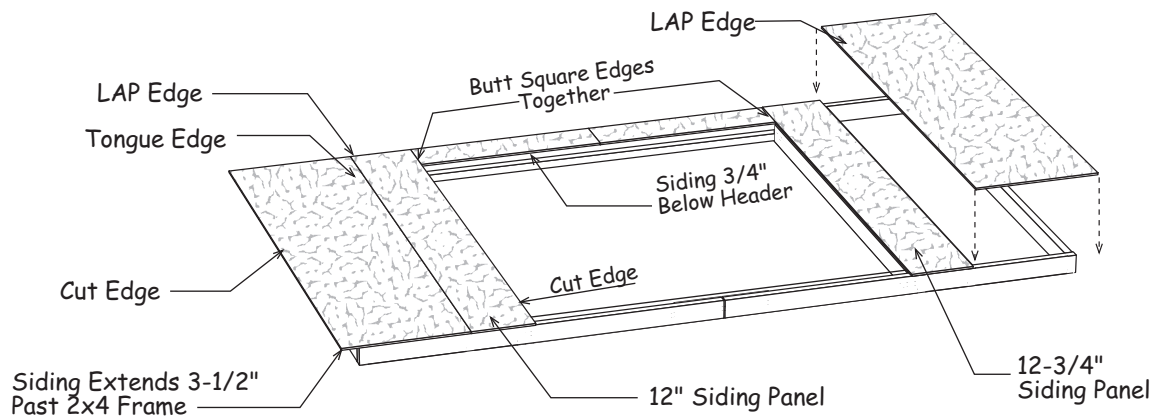

Step 6 Assemble Sidewalls

1. Position (2) two 2x4-72" boards together and indicate with 'X' marks, where the wall studs will be located.

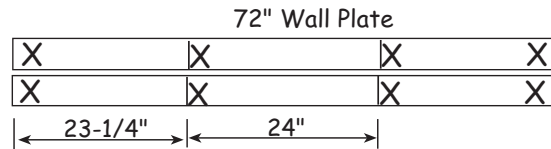

2. Install (4) four 80-1/4" long wall studs between the wall plates. Use (2) two 10d sinkers at each end of stud.

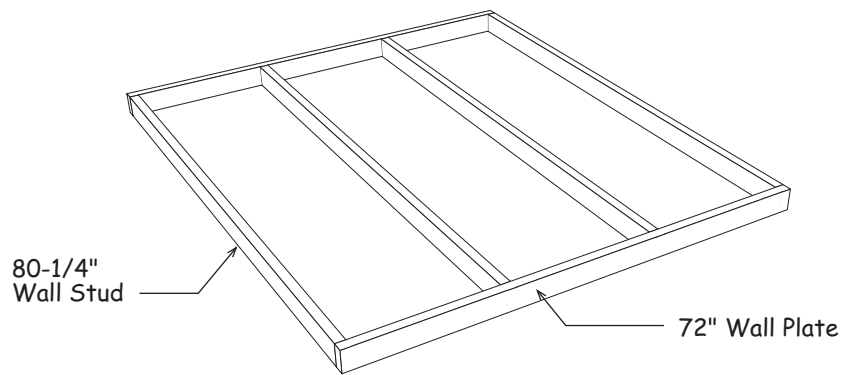

3. Repeat process to assemble (3) three more 72" wall frames.
4. Install (3) three 2x4-80-1/4" wall studs between (2) two 48" long 2x4s boards. Install the stud in the center of the wall frame.

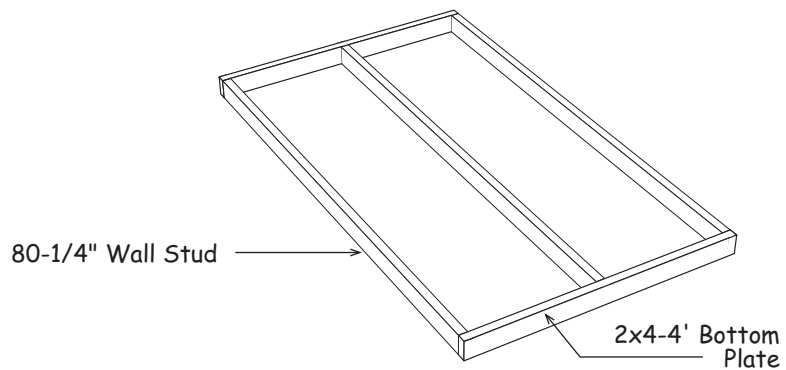

5. Repeat to assemble another 4' wall section.

Step 6 Assemble Sidewalls Continued

6. Position a 48" wide wall frame between (2) two 72" wall frames as shown below. Nail frames together with 10d sinkers.
7. Square wall frame. *Measure diagonally (corner to corner). The measurements will be the same when the wall is square.*

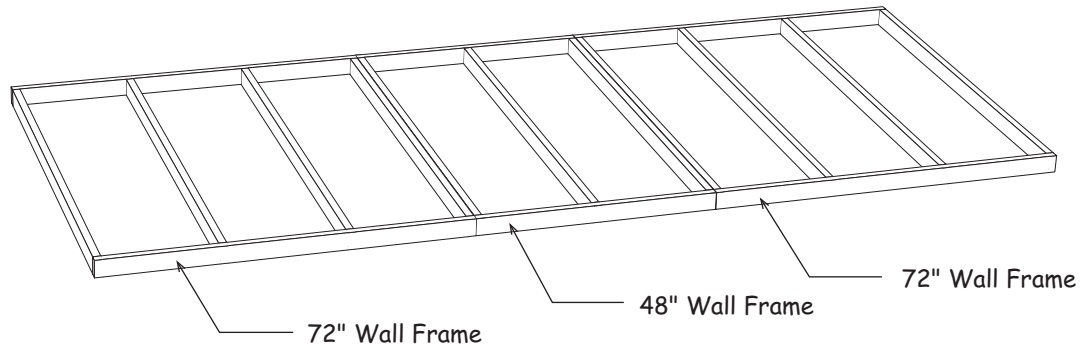

Cut the siding flush with the bottom plate if installing the building on a cement slab.

8. Install the first siding panel with the 'LAP edge' flush the end of the wall and extending 3/4" below the bottom plate.
9. Install (2) two more siding panels. You can install the last siding panel now or after the walls are erected so the panel will be easier to handle.

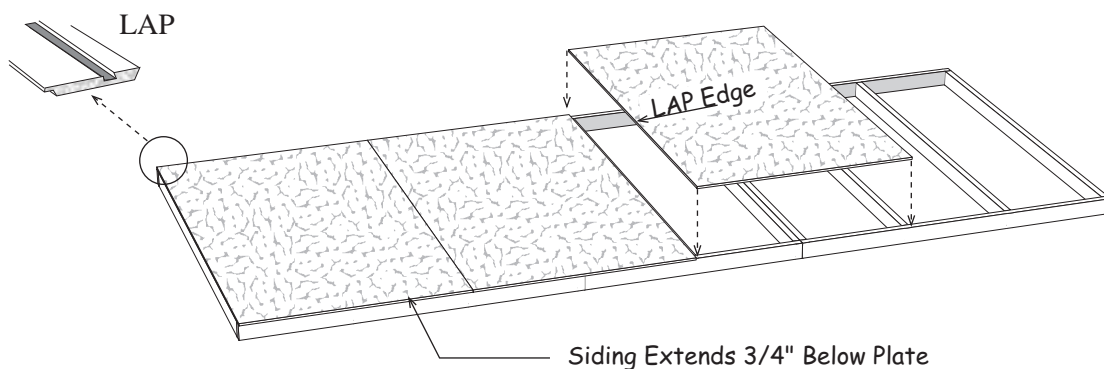

10. Repeat to assemble the another sidewall.

Step 7 Assemble Back Wall

1. Position (4) four 2x4x68-1/2" boards together and indicate with 'X' marks where the wall studs will be located. Mark the ends that will butt together with the letters 'A' and 'B'.
2. Install (8) eight 80-1/4" long wall studs, between the wall plates, over the 'X' marks and where the plates meet. Use (2) two 10d sinkers at each end of stud. Nail wall sections together using 10d sinkers.

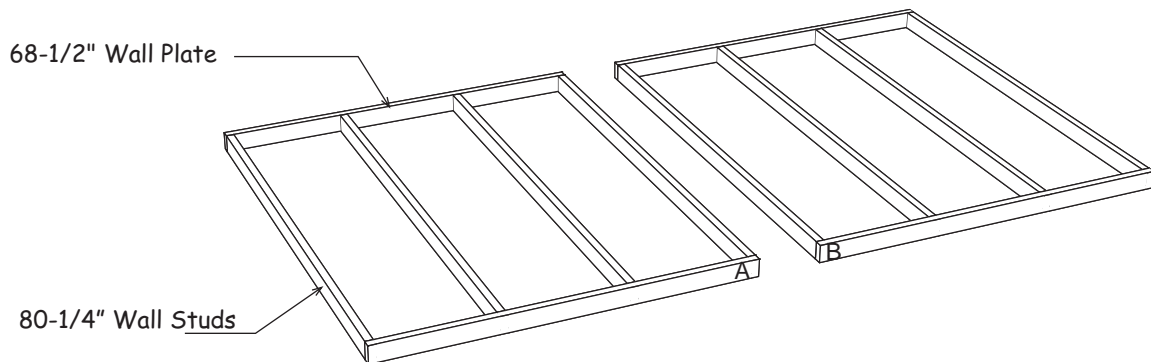
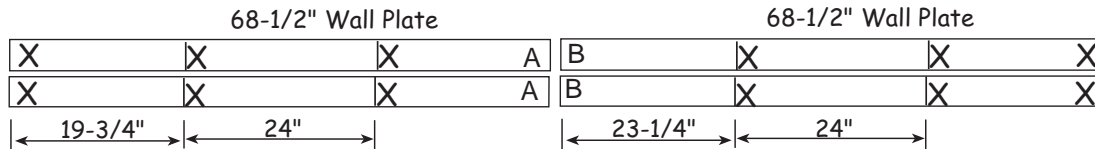

3. Square wall frame. *Measure diagonally (corner to corner). The measurements will be the same when the wall is square.*
4. Install the 1st siding panel with the 'LAP' edge extending 3-1/2" past the wall frame. The bottom will extend 3/4" below the bottom plate. Tip: Use 3/4" trim board as a gauge.
5. Install the other siding panels. Cut the last panel to extend 3-1/2" beyond the wall frame.

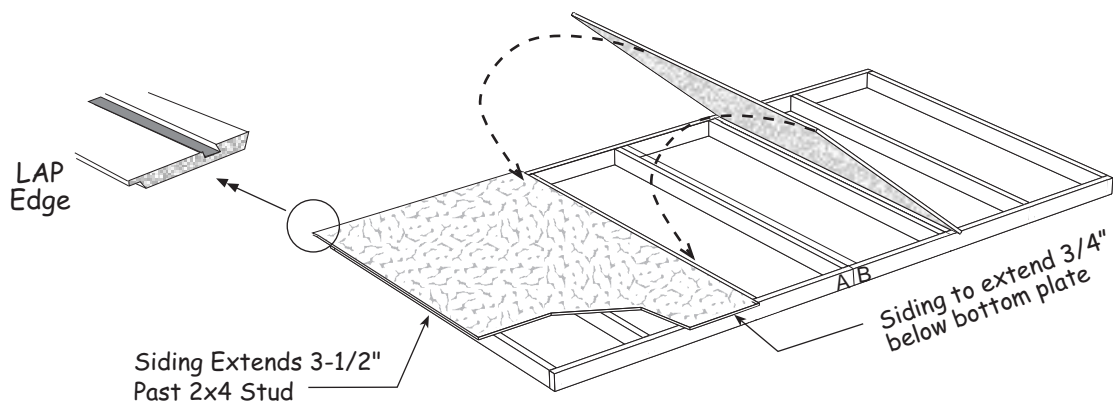

Step 8 Build Center Wall Brace & Set Walls

1. Disassemble the shipping pallet the siding and roof sheathing were shipped on.
2. Cut one of the 7' long 2x4s to a length of 53". Cut another 7' board to a length of 60".
3. Lay an 84" long and a 60" long 2x4 on a flat level surface.
4. Install another 84" and the 53" long 2x4 on top, 3-1/2" from the end of the lower 2x4s. Use 2-1/2" long wood screws. Use (2) two screws spaced 18" apart.

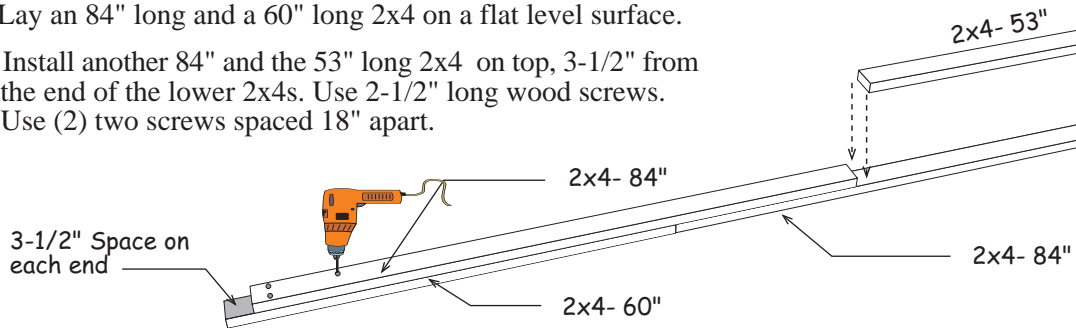

5. Set the back wall panel between the sidewalls. Secure wall panels together at the corners. Use (4) four 10d coated nails per corner. Nail wall panels to the floor. Nail through the bottom plate. Space 10d sinkers 24" apart.
6. Install the front wall frame between the sidewalls.
7. Install the last siding panel on the sidewalls. Nail along the siding edge where the sidewall siding panels overlap.
8. Disassemble the other shipping pallet and use one the 2x4s to brace the side wall where shown below. Save the other 2x4s. They will be used in **Step 12**.

9. Install the center Wall Brace between the sidewalls to hold them straight. See Detail 'D' top on next page.

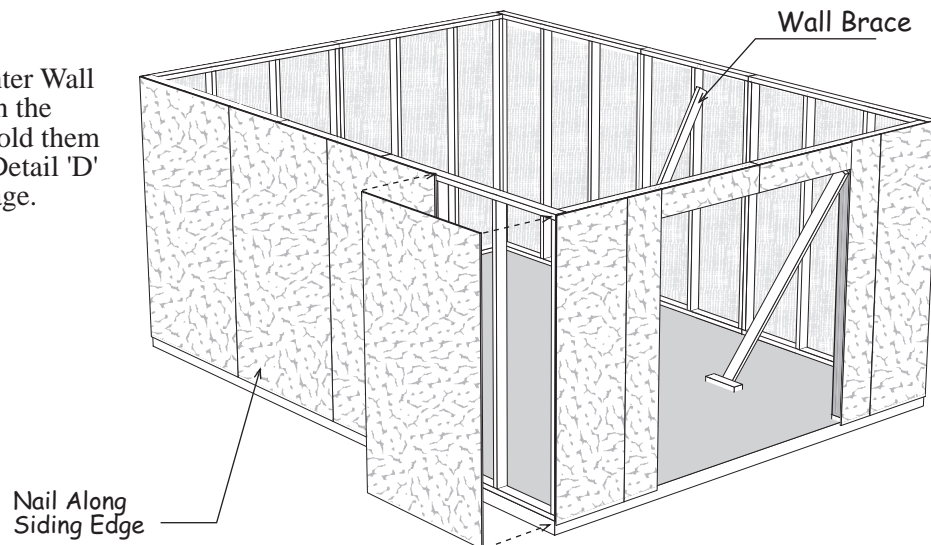

10. Remove the 2x4 door spacer and install it in the door opening to brace the front wall.
11. Cut and remove the bottom 2x4 in the door opening.

Step 8 Continued

Install the center Wall Brace in the center of the building between the sidewalls. Make sure the sidewalls are straight. The shorter 2x4s will butt against a wall stud. Secure the longer 2x4 to a wall stud at the side of the wall stud with (2) two 3" long wood screws.

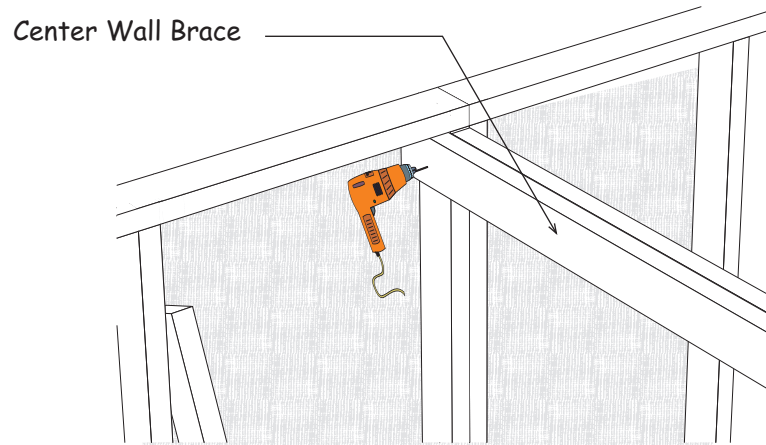

Step 9 Install 1x4 Trim

1. Install (2) two 84-1/2" long 1x4 corner trim on the back wall, flush with the siding on the sidewall and the top 2x4 wall plate. Use 8d galv. nails.
2. Install (2) two 1x4-72" trim boards across the top of the back wall. Cut to fit. Install the 1x4 boards flush with the top of the 2x4 top plate. *See diagram below.*
3. Repeat steps for front wall trim.

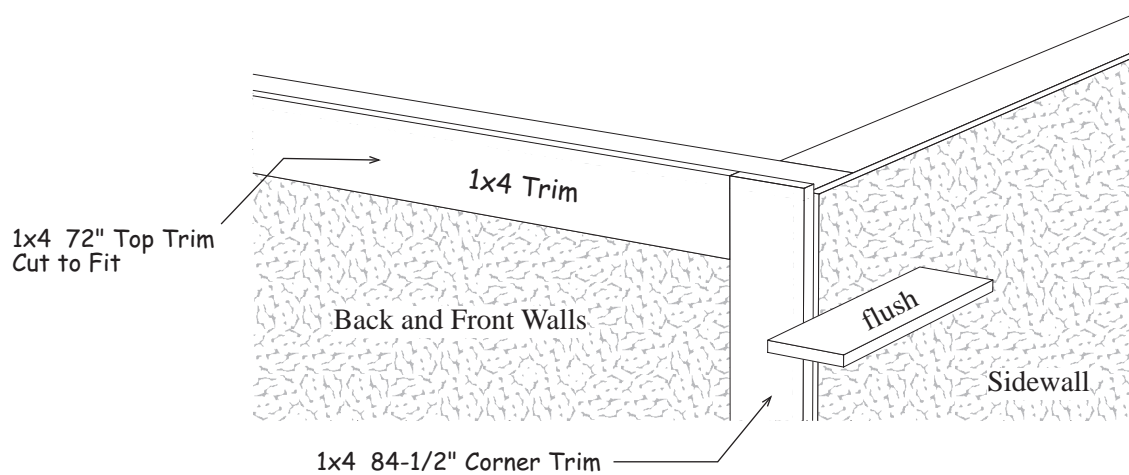

Step 10 Install Roof Gables

1. Install the rear gable on the rear wall. The siding on the gable must extend over the 1x4 trim board. *See detail.* Nail the gable to the 2x4 wall plate with 10d sinkers.
2. Install gable on front wall.

Bottom Edge of
Gable Siding

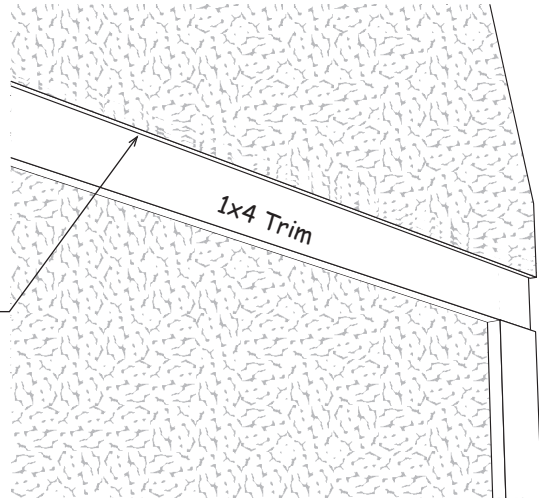

WARNING: The roof gables are heavy and awkward. You'll need helpers to lift and set gables in place.

Step 11 Install 2x4 Tie Plates on Sidewalls

1. Cut a 2x4-6' board in half and install a 3' long 2x4 board as a tie plate over the sidewall plate. Use 10d sinkers.
2. Install a 7' long 2x4 and cut another 7' long 2x4 to finish.
3. Repeat to install tie plates on the opposite sidewall.

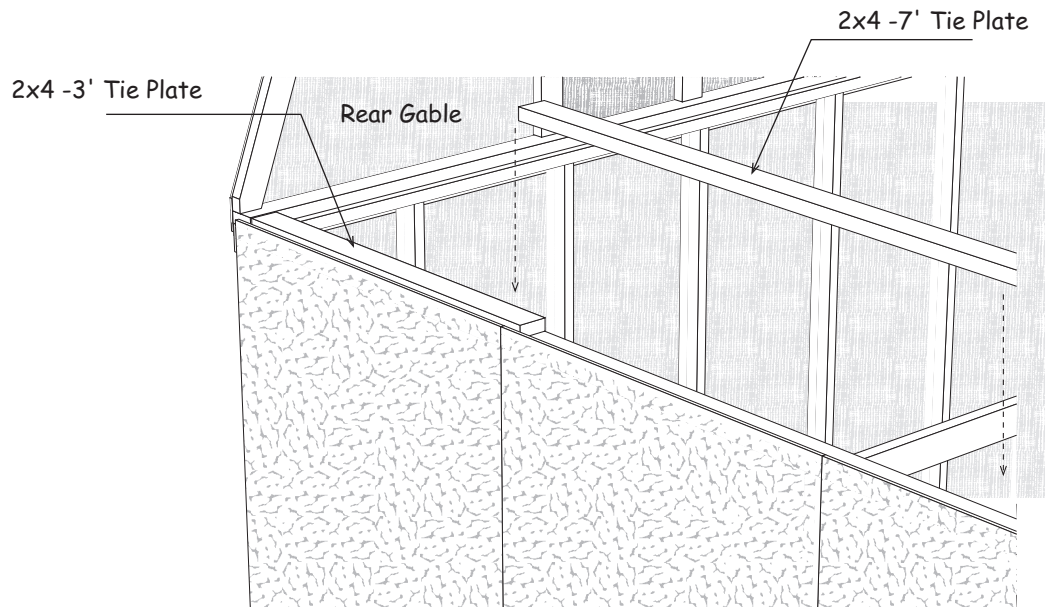

Step 12 Install Gable Support Shelf

1. Gather leftover 2x4-7 boards from the disassembled pallet in **Step 8**.
2. Butt (2) two 68-1/2" long 2x4s together. Fasten one of the 2x4s from the shipping pallet over the 2x4s and secure them with 2-1/2" wood screws spaced 18" apart.
3. Repeat to assemble another gable shelf board.

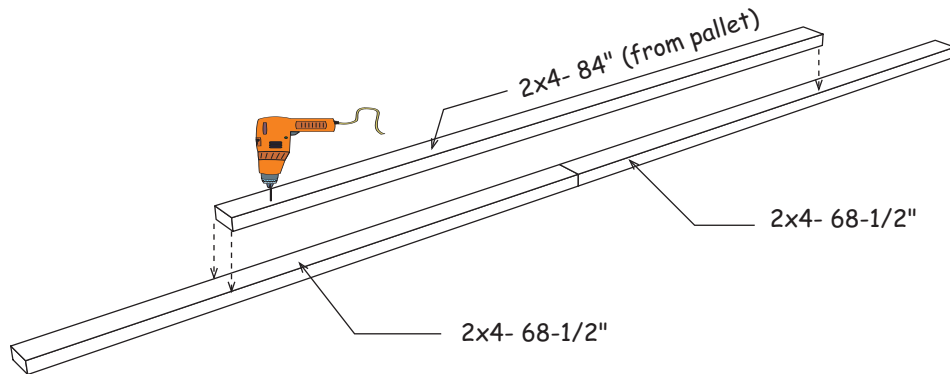

4. Cut a (2) two 2x4s to a length of 10-1/4".
5. Nail the 2x4 blocks to the rear corners, flush with the top of the 2x4 tie plate.
6. Nail one of the boards you assembled in previous step to blocks. Use 10d sinkers.
7. **Make sure the back wall is straight.** Nail (2) two 15" x 72" OSB panels across the 2x4 gable plate and the 2x4. Use 7d sinkers.
8. Repeat steps to install support shelf at the front wall.

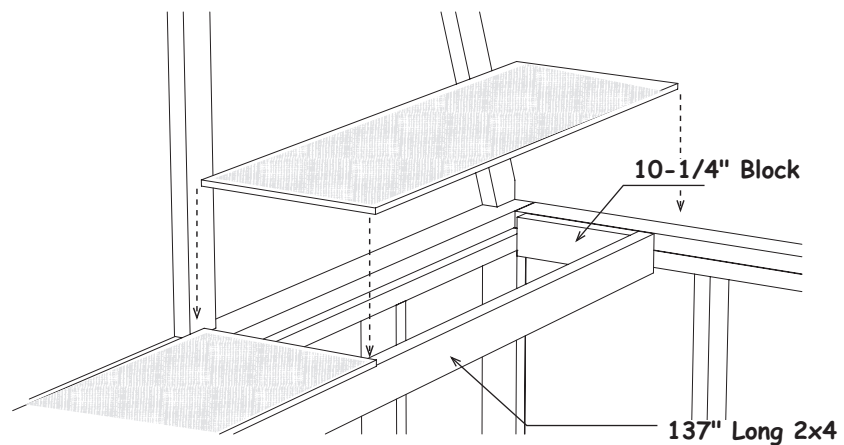

Step 13 Layout Roof Trusses

Starting at the back of the building, layout the truss spacing. Measure from the face of the gable trim to mark the location of the first truss. The last truss space will be more than 24".

Important: When marking the opposite wall, place the 'X' mark on the same side of the line so your trusses are parallel when they are installed.

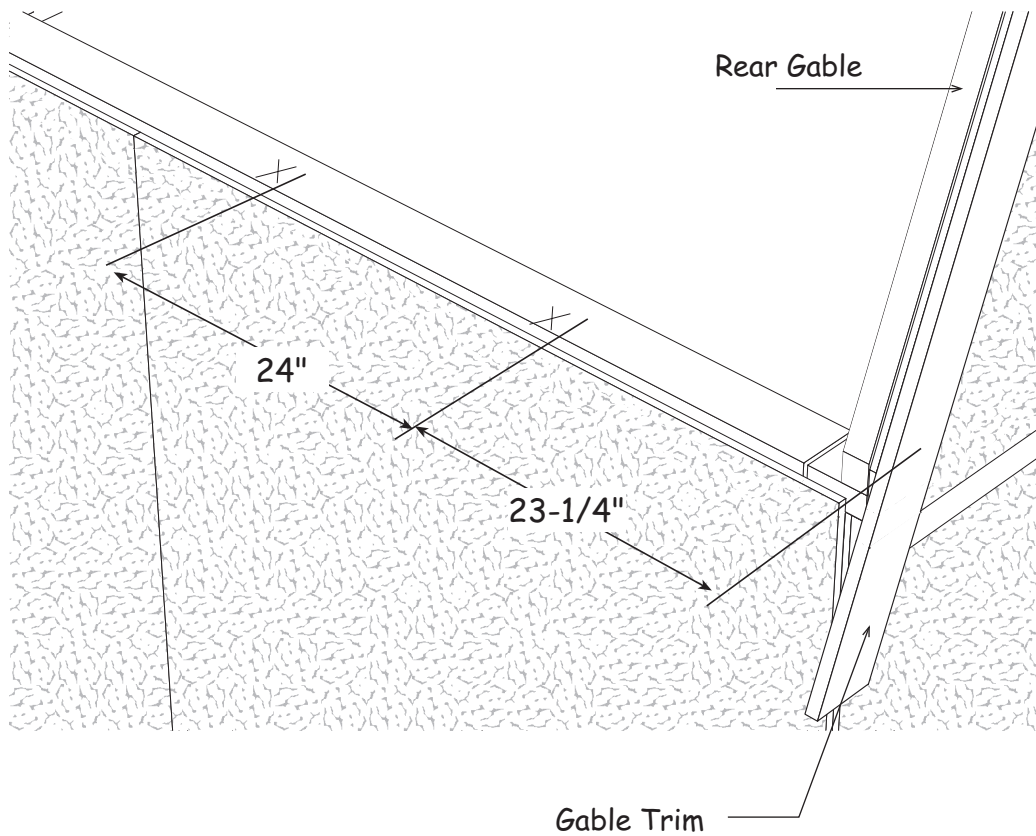

Step 14 Install Trusses & Soffit Boards

1. Place trusses over the 'X' marks. Install 2x4 hangers to the 2x4 plate using (4) four 1-1/2" hanger nails. Secure trusses to the 2x4 plate using 10d sinkers angled through the side of the hanger. See Detail 'E'
2. Locate 84" long soffit boards that have a beveled edge. Install one of these boards flush with the top of the siding and butting against the rear gable trim. Secure soffit boards to the top wall plate with 3" long screws. Cut the last soffit board to fit behind 1x4 trim on the front gable.

Metal Truss Hanger

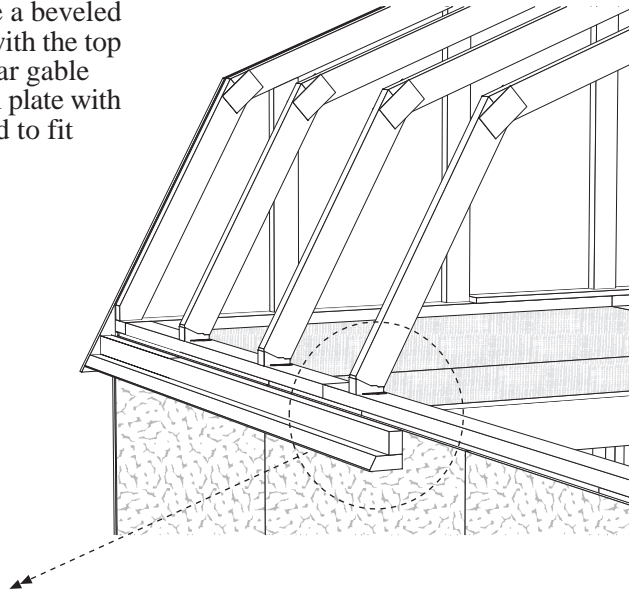
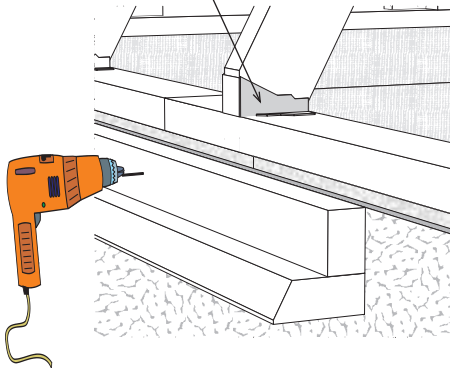

Soffit Board Flush With Siding

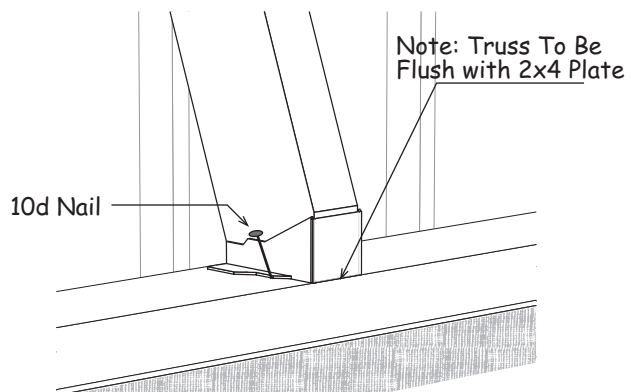

DETAIL 'E'

Step 15 Install Roof Sheathing

1. Install a 42" x 72" OSB roof panel flush with the face of the rear gable trim. Use a straight edge to align the top of the sheathing with the top of the truss. Continue adding sheathing following the layout below. Use 7d sinkers, spaced 12" apart.
2. Repeat step 1 for opposite side.

 To prevent the nails from protruding through the bottom of the soffit board, do not nail at an angle when nailing roof sheathing to the soffit boards.

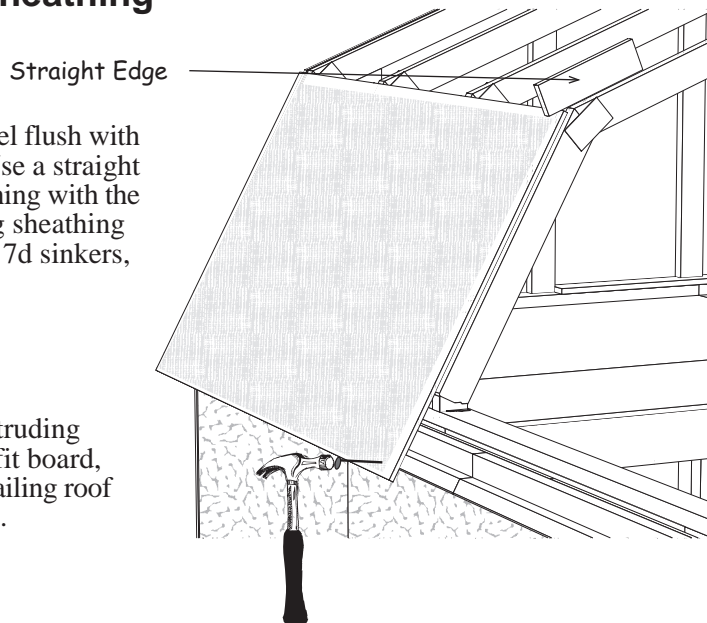

3. Apply roof sheathing across the top of the roof. There will be an air space at the peak of the trusses to allow for ventilation.

Insert (2) two plyclips into the roof sheathing between each truss at the top row.

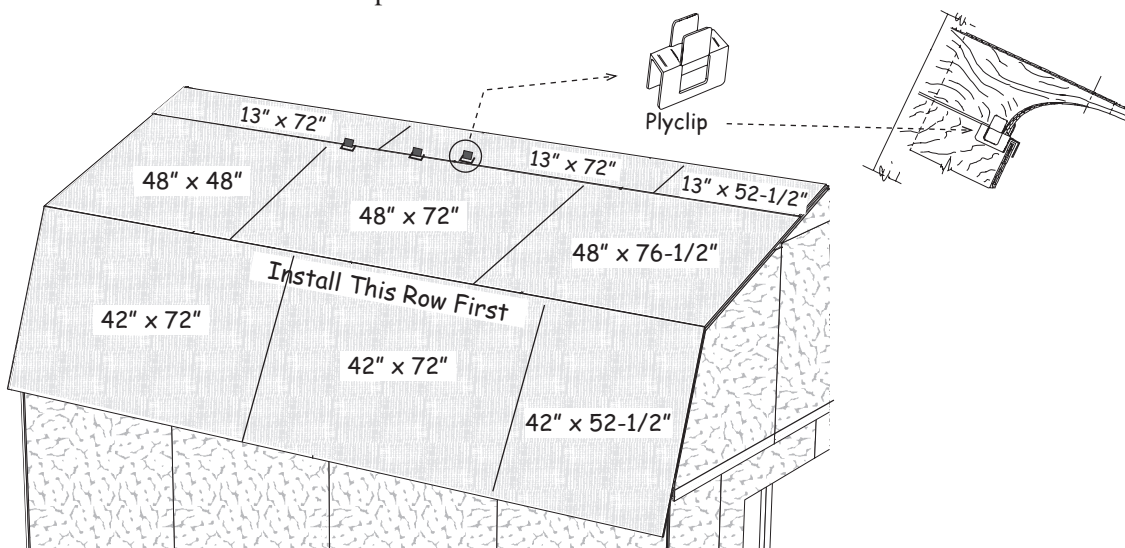

Step 16 Install Front Trim

1. Install loft door trim panel on the front gable by screwing through the back of the siding with 1" galv. screws.

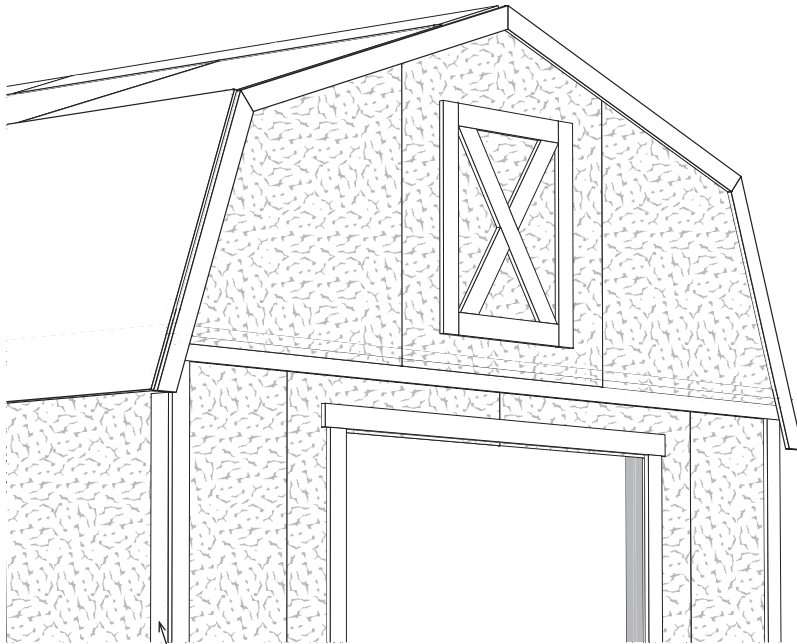

2. Install 80" long 1x4 trim boards on the corners of the sidewalls.
3. Install 1x4x76-3/4" trim boards along each side of the door opening. Tack these boards with a couple nails; you may want to move the trim later when you install the doors.
4. Install a 1x4x81-3/4" board, *that has angle cuts on both ends*, over the door opening.

Step 17 Install Roofing — Not Supplied in Kit

Install metal roof edging perimeter of the roof area. If you are not installing shingles at this time, you can purchase felt paper to protect the sheathing. Install the felt paper before you install the metal roof edge.

Install shingles according to the instructions on the wrapper. If you need more detailed instructions on installing shingles, there are good publications at book stores or newsstands.

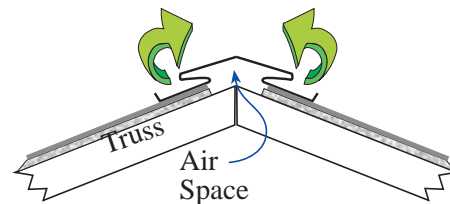

Optional ridge vent provides ideal ventilation.

Building Tip: Install ridge vent in lieu of shingles caps. Ridge vent provides ideal ventilation, preventing heat and moisture from damaging your building or its contents.

Step 18 Install Doors

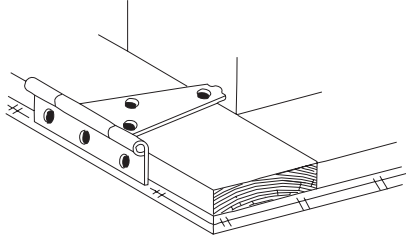

1. Lay the left door with the trim facing up. The siding on the left door extends past the door trim. See detail below.
2. Install 5" hinges to the left side of the door frame. To position the hinge properly, hold the rectangular plate against the frame. Use 1-3/4" black screws.
3. Install hinges to the right side of the other door.

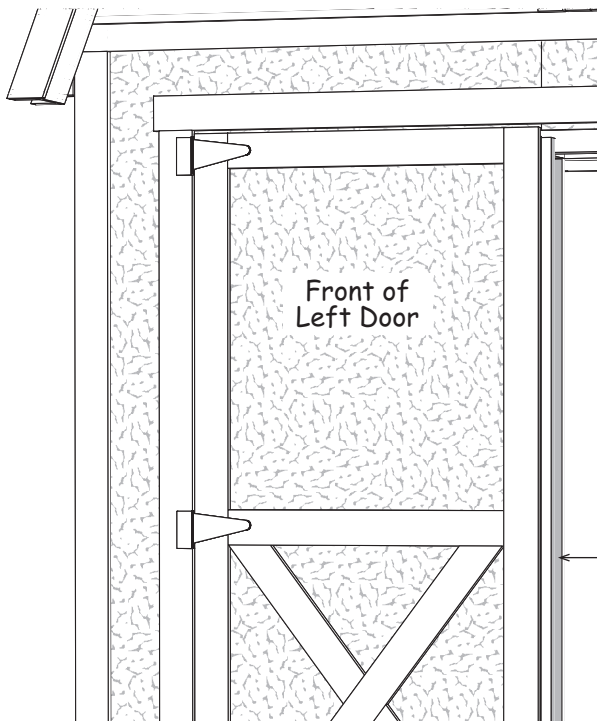

Before you fasten the hinges to the door trim, temporarily prop the doors in the opening. *Tip; set the door stop on a piece of siding to help hold the door in place.* Leave a space between the doors and the side trim to allow room for the doors to expand when they absorb moisture.

If your door opening is out of square, the space around the doors will not be even. You can reposition the side trim to make allowances for this. The side trim does not have to be flush with the frame of the door opening. You can move the trim in or out to make the door spacing equal.

Secure hinges to trim with 1-3/4" screws.

6. Install a barrel bolt, on the lower back of the door to secure this door in place when closed. Drill a hole for the round shaft to drop into.
7. Install another bolt at the top of the door.
8. Install door latch.

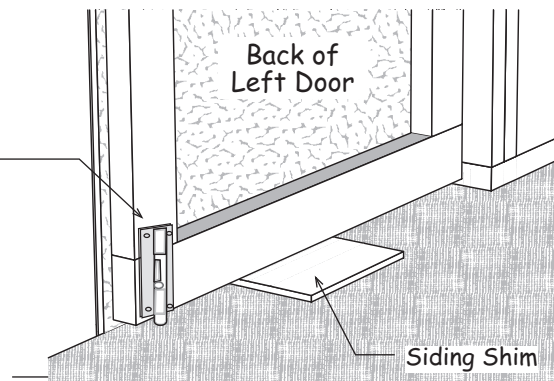

Denver-R 12'x 16' Barn kit

Qty.	Description	Size
2x4 Framing		
34	Wall Studs black ends	80 1/4"
2	Wall Studs wuth Door Jacks	80 1/4"
4	Tie Plates	84 "
15	Wall & Tie Plates	72 "
12	Wall Plates	68 1/2"
4	Wall Plates	48 "
2	Gable Studs	42 3/4"
4	Gable Studs	40 3/4"
4	Gable Studs	30 3/4"
2x6 Framing		
2	Door Header	75 "
2x3 Framing		
9	Truss Ridge Blocks	31 3/4"
Miscellaneous Lumber		
10	2 4 Blocks for Truss Jig	10" to 12"
1	OSB Door Header Filler	5-1/4" x 75"
14	Wood Gussets for Trusses	9" x 32"
Lower Wall Siding		Gable Siding
11	48" x 84"	4 48" x 56"
2	12" x 84"	4 24" x 39-3/4"
2	24" x 84"	
2	7-3/4" x 36" - over door opening	
Pre-built Components		
18	Pre-built Truss Halves	
2	36" x 76" Pre-built Barn Doors	
1	36" x 31" Pre-built Loft Door Frame	
6	3-1/2" x 84" Pre-built Soffit Boards	

Packing List 30-Oct-2013

Qty.	Description	Size
White Pine Trim		
4	1x4 Gable Trim	61 "
4	1x4 Gable Trim	42 1/2"
4	1x4 Lower Wall Trim	72 "
4	1x4 Corner Trim	84 1/2"
4	1x4 Corner Trim	80 "
1	1x4 Door Trim	81 3/4"
2	1x4 Door Trim	76 5/8"
Hardware		
5	lb. 10d Sinkers	32 7/16" Plyclips
3	lb. 8d Galv.	1 Bottle Glue
3	lb. 7d Sinkers	50 Black Screws
3	lb. 6d Common	14 Truss Hangers
1	lb. 6d Galv.	1 Door Hasp
1	lb. Hanger Nails	2 Barrell Bolts
13	1x4 Drive-on Plate	36 2-1/2" Screws
2	2" Screw Bit	50 3" Screws
		6 5" Door Hinges
7/16" OSB Sheathing		
2	48" x 76-1/2"	Roof Sheathing
2	48" x 72"	Roof Sheathing
2	48" x 48"	Roof Sheathing
4	42" x 72"	Roof Sheathing
2	42" x 52-1/2"	Roof Sheathing
4	13" x 72"	Roof Sheathing
2	13" x 52-1/2"	Roof Sheathing
4	15" x 72"	Gable Shelf

Shingles by Owner 12 Bundles Shingles 8 pcs. Roof 'drip' Edge