



DSH 600
DSH 600-X

English

1 Information about the documentation

1.1 About this documentation

- Read this documentation before initial operation or use. This is a prerequisite for safe, trouble-free handling and use of the product.
- Observe the safety instructions and warnings in this documentation and on the product.
- Always keep the operating instructions with the product and make sure that the operating instructions are with the product when it is given to other persons.

1.2 Explanation of symbols used

1.2.1 Warnings

Warnings alert persons to hazards that occur when handling or using the product. The following signal words are used:



DANGER !

- ▶ Draws attention to imminent danger that will lead to serious personal injury or fatality.



WARNING !

- ▶ Draws attention to a potential threat of danger that can lead to serious injury or fatality.



CAUTION !

- ▶ Draws attention to a potentially dangerous situation that could lead to slight personal injury or damage to the equipment or other property.

1.2.2 Symbols in the documentation

The following symbols are used in this document:

	Read the operating instructions before use.
	Instructions for use and other useful information
	Dealing with recyclable materials
	Do not dispose of electric equipment and batteries as household waste

1.2.3 Symbols in the illustrations

The following symbols are used in illustrations:

	These numbers refer to the corresponding illustrations found at the beginning of these operating instructions
3	The numbering reflects the sequence of operations shown in the illustrations and may deviate from the steps described in the text
	Item reference numbers are used in the overview illustrations and refer to the numbers used in the product overview section
	This symbol is intended to draw special attention to certain points when handling the product.
	Wireless data transfer

1.3 Product-dependent symbols

1.3.1 Symbols on the product

The following symbols are used on the product:

	Direction-of-rotation arrow on the guard
	Engine stop position
	Engine run position
	Primer bulb
	Idling jet adjusting screw
	Full-throttle jet adjusting screw
	Idling adjusting screw
	Fuel mixture
	Fuel-tank cap opening direction
	Choke (not -X)
	Wear ear protection, eye protection, respiratory protection and a hard hat
	Wear protective gloves
	Wear protective footwear
	Wireless data transfer

1.4 Adhesive labels on the machine

Warning signs

	Warning: Risk of fire due to flying sparks
	Warning: Risk of kickback
	Warning: Do not inhale toxic vapors or exhaust fumes
	Maximum spindle speed
	Warning: Hot surface

Prohibition symbols

	Do not use toothed cutting discs
	Do not use damaged cutting discs
	No smoking, no naked flame

1.5 Product information

products are designed for professional users and only trained, authorized personnel are permitted to operate, service and maintain the products. This personnel must be specifically informed about the possible hazards. The product and its ancillary equipment can present hazards if used incorrectly by untrained personnel or if used not in accordance with the intended use.

The type designation and serial number are printed on the rating plate.

- ▶ Write down the serial number in the table below. You will be required to state the product details when contacting Hilti Service or your local Hilti organization to inquire about the product.

Product information

Cut-off saw	DSH 600 DSH 600-X
Generation	01
Serial no.	

1.6 Declaration of conformity

We declare, on our sole responsibility, that the product described here complies with the applicable directives and standards. A copy of the declaration issued by the certification department can be found at the end of this documentation.

The technical documentation is filed here:

Hilti Entwicklungsgesellschaft mbH | Tool Certification | Hiltistrasse 6 | 86916 Kaufering, Germany

2 Safety

2.1 Personal safety

- ▶ Use the right tool for the job. Do not use the tool for purposes for which it was not intended. Use it only as directed and when in technically faultless condition.
- ▶ Never tamper with or modify the tool in any way.
- ▶ Only persons who are familiar with it, who have been trained on how to use it safely and who understand the resulting hazards are permitted to use the tool. The tool is not intended for use by children.
- ▶ Stay alert, watch what you are doing and use common sense when operating the tool. Do not use the tool while you are tired or under the influence of drugs, alcohol or medication. A moment of inattention while operating the tool can result in serious personal injury.
- ▶ The user and persons in the vicinity must wear ANSI Z87.1-approved protective goggles, a hard hat, ear protectors, protective gloves, protective footwear and light respiratory protection while the tool is in use.
- ▶ Always hold the tool firmly with both hands on the grips provided. Keep the grips dry, clean and free from oil and grease.
- ▶ Never use the tool without the guard (hood). Adjust the guard to the correct position. The guard must be securely attached and positioned for maximum safety, so that the smallest possible part of the cutting disc is exposed to the operator. Make sure that sparks created during use do not present a hazard. The guard helps to protect the operator from broken disc fragments, inadvertent contact with the cutting disc and uncontrolled flying sparks.
- ▶ Before using the tool, or if an obstacle is contacted while the tool is in use, check the guard immediately for possible damage. Replace the guard immediately if it is damaged or broken.
- ▶ Do not touch rotating parts – risk of injury!
- ▶ Maintain a firm footing and balance at all times. This will allow you to control the tool better, even in unexpected situations, for example, in the event of experiencing kickback or rotational forces. Avoid unusual postures.
- ▶ Wear suitable work clothes. Do not wear jewelry or loose clothing. Keep your hair, clothing and gloves away from moving parts. Loose clothes, jewelry or long hair can be snagged by moving parts.
- ▶ Releasing the throttle safety grip when the tool is running at full speed causes the tool to flick forward slightly because of the braking torque. Be prepared for this and keep a firm grip on the tool with both hands on the grips provided.
- ▶ If the tool or the cutting disc has been dropped or has fallen, check the tool and the cutting disc for damage. Change the cutting disc if necessary.
- ▶ Switch the tool off before adjusting the guard or changing the cutting disc.
- ▶ Wear protective gloves when changing the cutting disc. Touching the cutting disc presents a risk of injury (cuts or burns).

- ▶ Make sure fire extinguishers are available for use as there is a risk of fire due to flying sparks and the use of flammable fuel.
- ▶ Do not use reducing sleeves.
- ▶ Use of the wet cutting method is preferable in order to reduce the amount of dust produced when cutting mineral materials and asphalt.
- ▶ Avoid skin contact with the slurry created when using the wet cutting method.
- ▶ Dust from materials such as paint containing lead, some types of wood, minerals and metal can be harmful to health. Contact with or inhalation of the dust can cause allergic reactions and/or respiratory or other diseases to the operator or bystanders. To reduce the amount of dust produced when cutting, we recommend use of the wet cutting method. Make sure that the workplace is well ventilated. It is advisable to wear a filter class P2 dust mask. Comply with national regulations applicable to the materials you will be working with.
- ▶ Cutting material containing asbestos is not permissible.
- ▶ Take breaks between working and do relaxation and finger exercises to improve the blood circulation in your fingers. Exposure to vibration during long periods of work can lead to disorders of the blood vessels and nervous system in the fingers, hands and wrists.
- ▶ Consult the responsible structural engineer, architect or person in charge of the building project before starting work. Slits cut into load-bearing walls or other structures can influence the statics of the structure, especially when reinforcing bars or load-bearing components are cut.
- ▶ If the work involves breaking through, always secure the area on the side opposite to where the work is being carried out. Pieces of debris could drop out and/or fall down and injure other persons.
- ▶ Never leave the tool running while unattended. Switch the engine off and wait until the cutting disc has come to a complete standstill before placing the tool on the ground or before transporting it.
- ▶ Make sure that the pump cover is installed if you operate the tool without an external water pump.
- ▶ Switch the tool off after use.
- ▶ Maintain the tool carefully. Check for parts that are broken or damaged to the extent that the tool is not in full working order. Have damaged parts repaired before using the tool.
- ▶ To avoid risk of injury, use only genuine **Hilti** accessories and accessory tools.
- ▶ Have the tool repaired only by qualified specialists using only genuine Hilti spare parts. The safety of the tool can thus be maintained.
- ▶ Comply with national health and safety requirements.

2.2 Electrical safety

- ▶ Before beginning work, check the working area for concealed electric cables or gas and water pipes. External metal parts of the machine may give you an electric shock if you damage an electric cable accidentally.

2.3 Safety at the workplace

- ▶ Ensure that the workplace is well lit.
- ▶ Don't work in closed rooms. Carbon monoxide, unburned hydrocarbons and benzene in the exhaust gas may cause asphyxiation.
- ▶ Keep the workplace tidy. Objects which could cause injury should be removed from the working area. Untidiness at the workplace can lead to accidents.
- ▶ Hot exhaust gases containing sparks or sparks generated by the cutting operation may cause fire or explosion. Take care to ensure that the sparks generated do not ignite flammable (gasoline, dry grass, etc.) or explosive (gas, etc.) substances.
- ▶ Before fitting the water pump, check to ensure that the maximum permitted water supply pressure of 6 bar is not exceeded.

2.4 Liquids (gasoline and oil) and vapors

- ▶ Allow the product to cool before refueling.
- ▶ Never smoke while refueling.
- ▶ Don't refuel the product at the workplace area. When refueling, take care to avoid fuel spillage. Use a suitable funnel.
- ▶ Avoid inhaling gasoline vapors and exhaust fumes. Take care to ensure adequate ventilation.
- ▶ Don't use the gasoline or other flammable liquids for cleaning.

2.5 Cutting work using cutting discs

- ▶ Use only cutting discs with a rated maximum permissible speed that's at least as high as the highest spindle speed.
- ▶ Check that the outside diameter and the thickness of the cutting disc comply with the capacity rating of the product.
- ▶ Never use cutting discs that are damaged, run untrue or vibrate.
- ▶ Do not use damaged diamond cutting discs (cracks in the steel disc, broken or polished segments, damaged arbor hole, bent or distorted steel disc, heavy discoloration due to overheating, steel disc worn away beneath the segments, diamond segments with no lateral overhang, etc.).
- ▶ Do not use toothed accessory cutting tools (e.g. toothed saw blades).
- ▶ When fitting the cutting disc, always take care to ensure that the disc's specified direction of rotation corresponds to the direction of rotation of the spindle.
- ▶ The cutting disc and flange or any other accessory must fit the arbor of the product exactly. Cutting discs or accessories with arbor holes that do not match the mounting hardware of the product will run out of balance, vibrate excessively and may cause loss of control.
- ▶ Always use an undamaged clamping flange of the correct diameter which fits the cutting disc used. The correctly fitting clamping flange supports the cutting disc and thus reduces the possibility of disc breakage.
- ▶ Guide the product smoothly and do not apply lateral pressure to the cutting disc. Always bring the cutting disc into contact with the workpiece at right angles. Don't attempt to alter the line of cut by applying lateral pressure or by bending the cutting disc while cutting is in progress.
- ▶ Wear protective gloves when changing the cutting disc as the disc will get hot during use.
- ▶ Abrasive cutting discs which are used for wet cutting must be used up the same day as long periods of exposure to moisture have a negative effect on the strength of the disc.
- ▶ Observe the expiry date for resin-bonded cutting discs and don't use the discs after this date.

2.6 Transport and storage

- ▶ Switch the product off before transporting it.
- ▶ Remove the cutting disc from the product after use. The cutting disc may suffer damage during transport with the disc fitted.
- ▶ Handle the cutting disc carefully and store it in accordance with the manufacturer's instructions.
- ▶ Always store and transport the product in an upright position, not lying on its side.
- ▶ Do not transport the product by crane.
- ▶ Store the product in a secure place when not in use. Products which are not in use must be stored in a dry, high place or locked away out of reach of children.
- ▶ When laying the product down, make sure that it stands securely.
- ▶ After use, allow the product to cool down before packing it away or placing a cover over it.
- ▶ Store gasoline and oil in a well-ventilated room in fuel containers that comply with regulations.

2.7 CALIFORNIA PROPOSITION 65



DANGER

Fuels used in gas or oil filled appliances and the product of combustion of such fuels contain chemicals (including Benzene, toluene, xylenes, 1,3 butadiene and formaldehyde) known to the State of California to cause cancer, birth defects or other reproductive harm. **Wash hands after handling!**

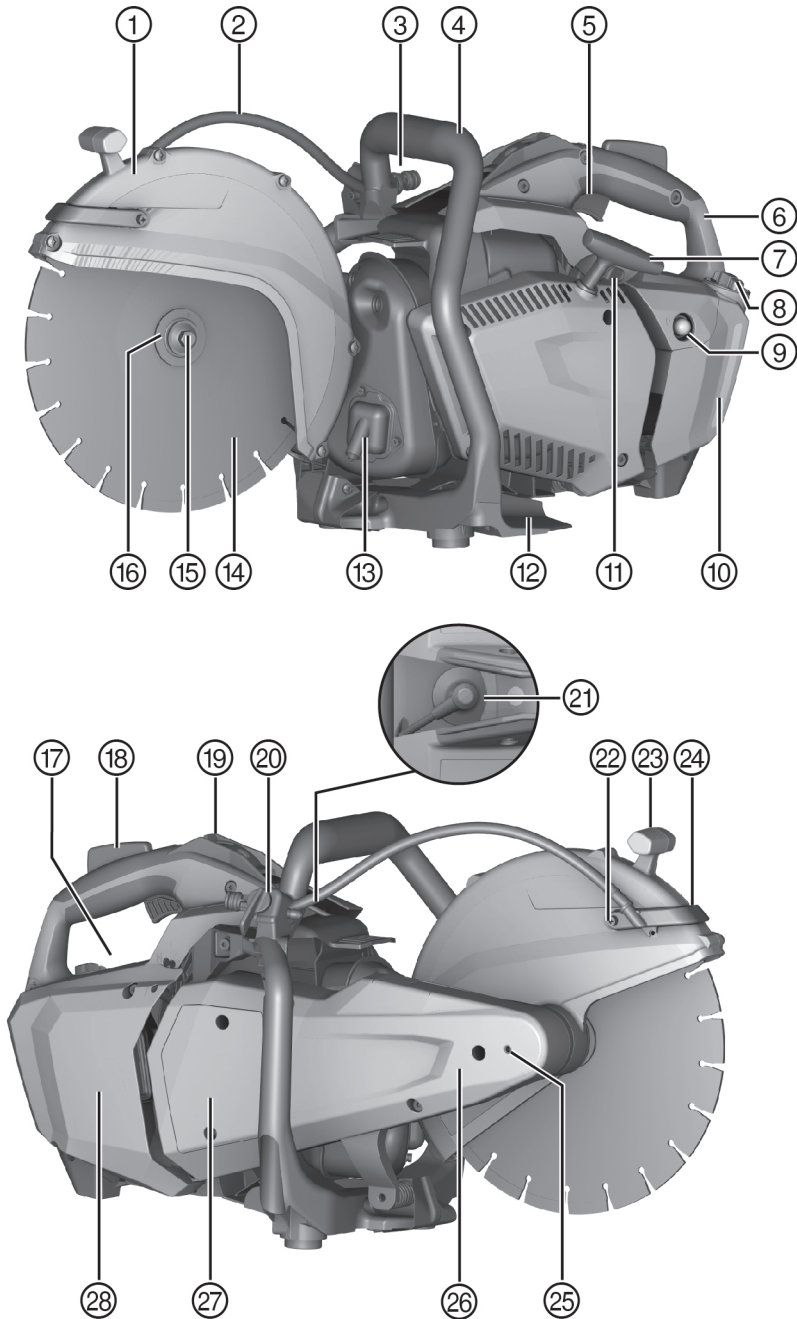
3 Description**3.1 Product overview****3.1.1 Gasoline-powered cut-off saw**

- | | |
|---------------------------------------|---|
| ① Guard | ⑰ Rating plate |
| ② Water supply | ⑱ Throttle safety grip (DSH 600) |
| ③ Water connection | ⑲ Safety grip with integrated brake actuation (DSH 600-X) |
| ④ Front grip | ⑳ Start/stop switch with integrated half-throttle lock |
| ⑤ Throttle trigger | ㉑ Water cock |
| ⑥ Rear grip | ㉒ Spark plug connector |
| ⑦ Recoil starter pull handle | ㉓ Cleaning screw for water nozzle |
| ⑧ Fuel tank cap | ㉔ Grip for guard adjustment |
| ⑨ Primer bulb | ㉕ Curved water distributor with integrated water nozzles |
| ⑩ Fuel level indicator | ㉖ Hole for locking pin for changing cutting discs |
| ⑪ Choke lever (DSH 600) | ㉗ Saw arm |
| ⑫ Footplate | ㉘ Pump cover |
| ⑬ Exhaust discharge with spark filter | ㉙ Air filter cover |
| ⑭ Cutting disc | |
| ⑮ Clamping screw | |
| ⑯ Clamping flange | |

3.2 Intended use

The product described is a gasoline-powered cut-off saw for the wet or dry cutting of asphalt, mineral construction materials or metals using diamond cutting discs or abrasive cutting discs.

The saw is not suitable for use in environments where there is risk of fire or explosion.

3.3 Possible misuse

- ▶ “Shoveling” with the gasoline-powered saw is not permissible.

3.4 Instructions for use

- Use of the wet cutting method is preferable in order to reduce the amount of dust produced when cutting. By using the self-priming water pump (accessory) you can work without need for a water supply hose. The water can be drawn, for example, directly from a container.
- Do not cut right through the workpiece in one pass. Move the saw back and forward several times until it gradually reaches the desired cutting depth.
- To avoid damaging the diamond cutting disc when dry cutting, lift the disc out of the cut for approx. 10 seconds every 30 to 60 seconds while the saw is still running.
- Resharpener a polished diamond disc (i.e. when no diamonds project from the segment matrix) by cutting with the disc in a very abrasive material such as sandstone.

3.5 Cutting disc specifications

Diamond cutting discs in accordance with ANSI B7.1 are to be used with the product. Synthetic resin-bonded, fiber-reinforced cutting discs in accordance with ANSI B7.1 (straight, not dish-shaped, type cutting-off wheel) may also be used with the product for working on metals.

The disc mounting instructions and instructions for use issued by the cutting disc manufacturer must be observed.

3.6 Items supplied

Gasoline-powered cut-off saw, DSH 600/DSH 600-X tool set, DSH 600/DSH 600-X consumables set, operating instructions.

You can find other system products approved for your product at your local **Hilti** Center or online at: www.hilti.com

3.7 Saw blade brake

DSH 600-X

The product is equipped with an integrated saw blade brake to increase operator safety. The saw blade is braked to a standstill in a maximum of 10 seconds after the throttle safety grip is released.

 Releasing the throttle safety grip when the tool is running at full speed causes the tool to flick forward slightly because of the braking torque. So hold the tool firmly with both hands on the grips provided.

3.8 Consumables and wearing parts

- Air filter
- Cord (5 pcs)
- Starter
- Fuel filter
- Spark plug
- Tool set
- Cylinder set
- Mounting screw assy.
- Flange for abrasive cutting disc (with integral centering ring 20 mm/1")
- Flange for diamond cutting disc (with integrated centering ring 20 mm/1")

4 Technical data

4.1 Gasoline-powered cut-off saw

	DSH 600	DSH 600-X
Cubic capacity	3.86 in ³ (63.3 cm ³)	3.86 in ³ (63.3 cm ³)
Weight with diamond disc flange, without cutting disc, tank empty	21.50 lb (9.75 kg)	21.72 lb (9.85 kg)
Rated power at 8,500/min in accordance with ISO 7293	4.3 hp (3.2 kW)	4.3 hp (3.2 kW)
Maximum spindle speed	5,500 /min	5,500 /min
Maximum cutting depth	4.7 in (120 mm)	4.7 in (120 mm)
Carburetor	Walbro; model: WT-1207	Walbro; model: WT-1203

4.2 Additional technical data

Engine type	Single-cylinder, air-cooled two-stroke engine
Maximum engine speed	9350 ± 200 /min
Idle speed	2900 ± 200 /min
Ignition (type)	Electronic
Electrode gap	0.02 in (0.5 mm)
Spark plug	NGK, type: CMR7A-5
Tightening torque for fitting the spark plug	9 ftlb, (12 Nm)
Fuel mixture	API-TC oil 2% (1:50)
Tank capacity	870 cm ³
Tank capacity	29.4 oz

Cutting disc arbor size / diameter of centering bush	0.8 in (20 mm)
Cutting disc arbor size / diameter of centering bush	1.00 in (25.4 mm)
Minimum flange outside diameter for diamond cutting discs (only for steel-core discs; the flanges are marked with "FOR DIAMOND ABRASIVE STEEL CORE WHEELS ONLY")	2.4 in (60 mm)
Minimum flange outside diameter for abrasive cutting discs (composite discs)	3.1 in (78 mm)
Maximum disc outside diameter	12 in (300 mm)
Maximum nominal disc thickness (only for steel core discs)	0.18 in (4.5 mm)
Maximum nominal disc thickness (composite discs)	0.16 in (4.0 mm)
Tightening torque for fitting the cutting disc	18 ftlb, (25 Nm)

5 Before use

5.1 Fuel

The two-stroke engine runs on a mixture of gasoline and oil. The quality of the fuel mixture decisively influences operation and life expectancy of the engine.

DANGER

Risk of fire and explosion. Gasoline vapors are highly flammable.

- ▶ Never smoke while refueling.
- ▶ Don't refuel the product at the area where you are working (move at least 3 meters (10 feet) away from the working area).
- ▶ Don't refuel the product while the engine is running. Wait until the engine has cooled down.
- ▶ Make sure there are no naked flames or sparks that could ignite the gasoline vapors.
- ▶ Take care to avoid fuel spillage. If fuel is spilled, clean up the areas affected immediately.
- ▶ Check to ensure there is no leakage from the fuel tank.

CAUTION

Risk of injury. The inhalation of gasoline vapors and skin contact with gasoline may be hazardous to the health.

- ▶ Avoid direct skin contact with gasoline. Wear protective gloves.
- ▶ If your clothing becomes soiled with gasoline, it is essential to change your clothing.
- ▶ Ensure that the workplace is well ventilated in order to avoid breathing in gasoline fumes.
- ▶ Use a fuel container that complies with the applicable regulations.

5.1.1 Using two-stroke oil

- ▶ Use good-quality, two-stroke oil for air-cooled engines that meets at least the API-TC specification.

5.1.2 Gasoline

- ▶ Use regular or super gasoline with an octane rating of at least 89 ROZ.



The alcohol content (e.g. ethanol, methanol or others) of the fuel used must not exceed 10%, otherwise the life expectancy of the engine will be greatly reduced.

5.1.3 Mixing fuel



The engine will suffer damage if run with fuel mixed in the wrong ratio or with unsuitable oil.

Use a mixing ratio of 1:50. This corresponds to 1 part good-quality two-stroke oil that complies with the API-TC specification and 50 parts gasoline (e.g. 100 ml oil and 5 liters of gasoline mixed in a suitable canister).

1. Pour the required quantity of two-stroke oil into the fuel canister.
 2. Then fill the gasoline into the fuel canister.
 3. Close the fuel canister.
 4. Mix the fuel by shaking the fuel container.
-



If the quality of the two-stroke oil or the gasoline is unknown, then increase the mixing ratio to 1:25.

5.1.4 Filling the fuel tank

1. Mix the fuel (two-stroke oil / gasoline mixture) by shaking the fuel container.
2. Place the product in a steady upright position.
3. Open the fuel tank by turning the cap counterclockwise and then removing the cap.
4. Fill the tank slowly using a funnel.
5. Close the fuel tank by fitting the cap and then turning it clockwise.
6. Close the fuel canister.

5.2 Assembly and adjustment



WARNING

Risk of injury. Contact with the rotating cutting disc can lead to injury. Hot parts of the machine or a hot cutting disc may cause burning injuries.

- ▶ Before fitting or adjusting any parts of the product, make sure that the engine is switched off, that the cutting disc has completely stopped rotating and that the product has cooled down.
 - ▶ Wear protective gloves.
-

5.2.1 Fitting a cutting disc



WARNING

Risk of injury and damage. Unsuitable cutting discs or unsuitable parts used to secure the disc can suffer irreparable damage during operation or lead to loss of control of the tool.

- ▶ Make sure that the cutting disc's maximum permissible speed is at least as high as the maximum speed stated on the tool. Use only cutting discs, flanges and screws that fit the tool.
 - ▶ Use only cutting discs with an arbor size (mounting hole diameter) of 20 mm or 25.4 mm (1").
 - ▶ Use only the large flange with a diameter of 78 mm / 3" to secure an abrasive cutting disc.
-



CAUTION

Risk of injury and damage. Damaged cutting discs may break.

- ▶ If the cutting disc has been subjected to an impact, check the disc for damage and replace it if necessary.
 - ▶ Never use cutting discs that are damaged, run untrue or vibrate.
 - ▶ Don't use synthetic resin-bonded fiber-reinforced cutting discs which have exceeded their use-by date or already softened due to water absorption.
-

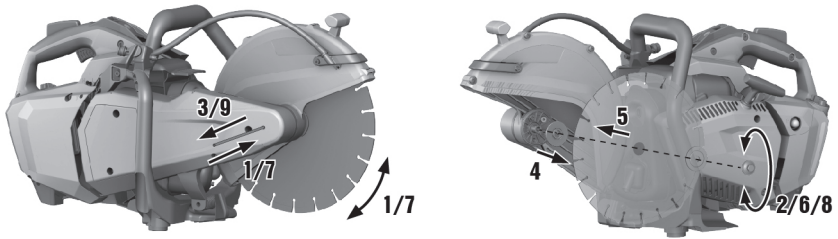

1. Insert the locking pin in the hole in the drive belt cover and turn the cutting disc until the locking pin engages.
2. Release the securing screw by turning the screw counterclockwise with the wrench and then remove the screw and washer.
3. Remove the locking pin.
4. Remove the clamping flange and the cutting disc.
5. Check that the diameter of the arbor hole in the cutting disc to be fitted matches the centering collar of the cutting disc mounting flange.



The mounting flange has a 20 mm diameter centering collar on one side and a 25.4 mm (1") diameter centering collar on the other side.

6. Clean the clamping and centering surfaces on the tool and on the cutting disc.

7. Select one of the following alternatives.

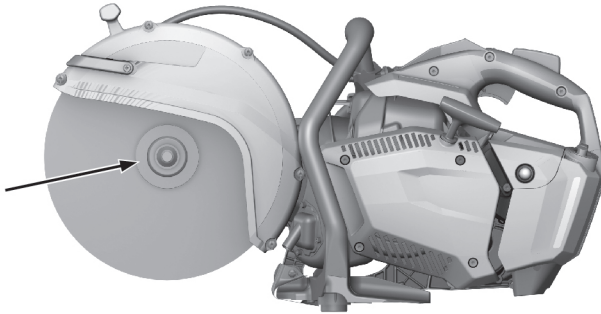

- ▶ Use only the large flange to secure the abrasive cutting disc.

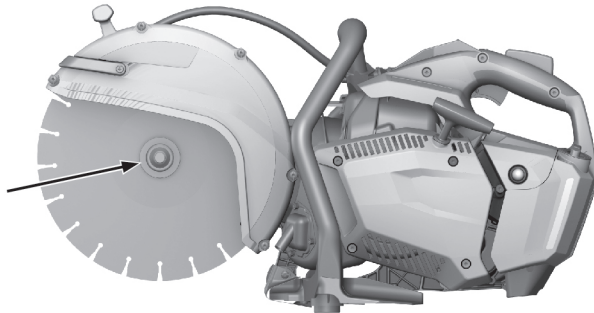

- ▶ Use the small flange with diamond cutting discs in order to utilize the full cutting depth.
8. Place the cutting disc with centering collar on the drive arbor and check that the direction of rotation is correct.
 - ◀ The direction-of-rotation arrow on the cutting disc must match the direction of rotation indicated on the tool.
 9. Place the clamping flange and washer on the drive arbor and tighten the securing screw by turning it clockwise.
 10. Insert the locking pin in the locking hole in the drive belt cover and turn the cutting disc until the locking pin engages.
 11. Securely tighten the clamping screw (tightening torque: 25 Nm).
 12. Remove the locking pin.



After fitting a new cutting disc, run the tool at full speed under no load for approximately 1 minute.

5.2.2 Adjusting the guard



DANGER

Risk of injury. Flying fragments or sparks could cause injury.

- ▶ Adjust the guard so that flying particles or fragments of the material removed and flying sparks are directed away from the operator and the product.
-
- ▶ Hold the guard by the grip provided and rotate it to the desired position.

5.2.3 Fitting the water pump (accessory)

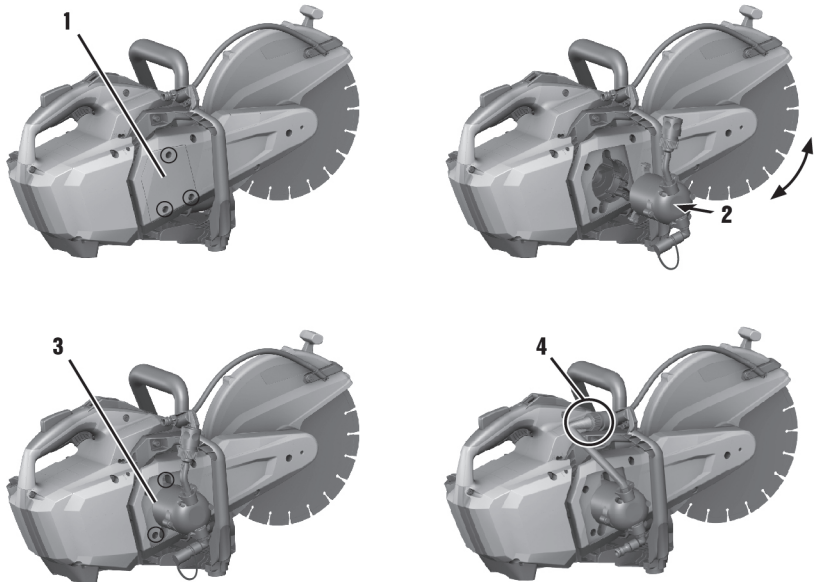

1. Release the three pump cover retaining screws, remove the parts and store the pump cover in a safe place.



The pump cover must be fitted if the tool is used without the water pump.

2. Hold the water pump in position and turn the cutting disc slightly to bring the splines of water pump and clutch bell into alignment so that the splines engage.
 - ◀ The position is keyed so it is not possible to position the pump incorrectly.
3. Fit the three retaining screws and tighten them securely (tightening torque: 8 Nm).
4. Connect the pump hose to the hose connector on the saw.
5. Remove the protective cap from the end of the water connection hose.
6. Connect the water pump to the water supply or immerse the end of the suction hose in a container filled with water.



The maximum permitted water supply pressure is 6 bar.



Fit the protective cap to the end of the water connection hose when the water pump is not connected to a water supply.

5.2.4 Removing the water pump (accessory)

1. Disconnect the water supply from the water pump.
2. Fit the protective cap to the end of the water connection hose.
3. Disconnect the connector between the pump and the tool.
4. Release the three fastening screws on the pump and then remove the pump.
5. Fit the pump cover on the tool, insert the three retaining screws and tighten the screws securely (tightening torque: 4 Nm).

5.2.5 Fitting the wheel set (accessory)

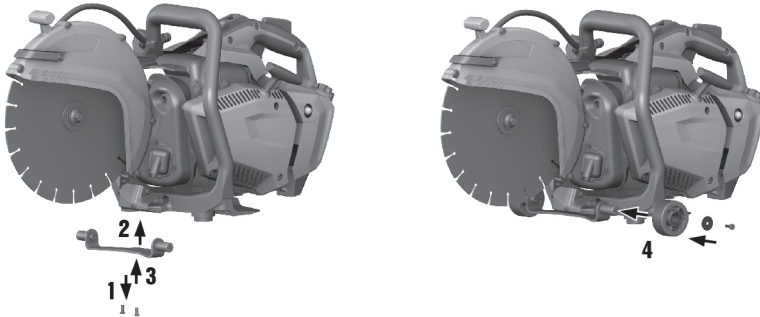

1. Slacken the two bottom securing screws on the metal guard.
2. Secure the base plate with the two screws.
3. Secure the wheels and washers with the screws on both sides of the base plate.

6 Operation

6.1 Starting the engine

DANGER

Risk of asphyxiation. Carbon monoxide, unburned hydrocarbons and benzene in the exhaust gas may cause asphyxiation.

- ▶ Don't work in closed rooms, trenches or pits and make sure the area is well ventilated.

WARNING

Risk of burning injury. The exhaust system gets extremely hot when the engine is running. It stays hot for a long time after the engine is switched off.

- ▶ Wear protective gloves and avoid touching the exhaust system.
- ▶ Do not lay the product down on flammable material while hot.

WARNING

Risk of injury. A damaged exhaust system will raise the noise level above the permissible limit and thus cause hearing damage.

- ▶ Never use the product if the exhaust system is damaged, missing or if it has been tampered with.

CAUTION

Risk of burns or injury through pinching the fingers when the water pump is fitted. Touching the pump housing can cause burning injuries.

- ▶ Hold the forward grip only at the top and on the left side.

1. If the following equipment exists, also take this action:

DSH 600

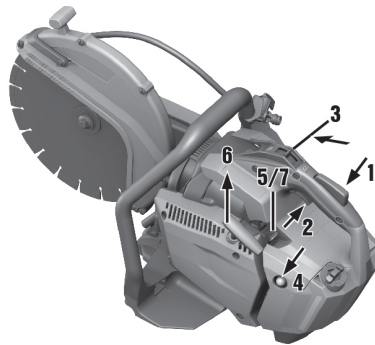

- ▶ Press and hold down the throttle safety grip.
- ▶ Press and hold down the throttle trigger.
- ▶ Move the start/stop switch to the “start” position.
- ▶ Release the throttle safety grip and throttle trigger.
 - ◀ The half-throttle position is activated.
- ▶ Squeeze the primer bulb 2 to 3 times until the primer bulb is completely filled with fuel.
- ▶ If the following conditions are met, also take this action:

Conditions: The engine is cold.

- ▶ Pull the choke lever up.
 - ◀ The choke is activated.
- ▶ Check that the cutting disc is free to rotate.
- ▶ Place your left foot on the footplate.
- ▶ Pull the recoil starter pull handle slowly with your right hand until resistance is perceptible.
- ▶ Vigorously pull the recoil starter pull handle.
- ▶ When you hear the engine start to fire (after 2 to 5 pulls of the starter), move the choke lever back down to its original position.
- ▶ Vigorously pull the recoil starter pull handle repeatedly until the engine fires.

 Too many start attempts with the choke activated will cause the engine to flood.

-
- ▶ Briefly press the throttle trigger as soon as the engine fires.
 - ◀ This disengages the half-throttle position and the engine will idle when the throttle trigger is released.

2. If the following equipment exists, also take this action:

DSH 600-X

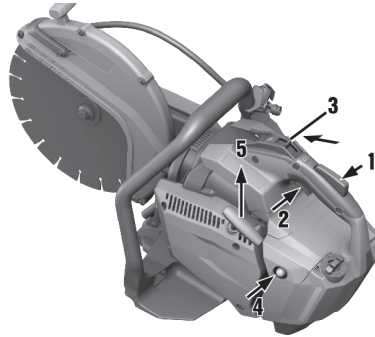

- ▶ Press and hold down the throttle safety grip.
- ▶ Press and hold down the throttle trigger.
- ▶ Move the start/stop switch to the “start” position.
- ▶ Release the throttle safety grip and throttle trigger.
 - ◀ The half-throttle position is activated.
- ▶ Squeeze the primer bulb 2 to 3 times to fill the primer pump bulb with fuel only when starting with the engine cold.
- ▶ Check that the cutting disc is free to rotate.
- ▶ Place your left foot on the footplate.
- ▶ Pull the recoil starter pull handle slowly with your right hand until resistance is perceptible.
- ▶ Vigorously pull the recoil starter pull handle.
- ▶ Repeat this procedure until the engine fires.
- ▶ Briefly press the throttle trigger as soon as the engine fires.
 - ◀ This disengages the half-throttle position and the engine will idle when the throttle trigger is released.

6.2 Checks after starting the engine

1. Check that the cutting disc remains stationary when the engine is idling and, after briefly running at full speed, that the disc again comes to a complete standstill.
 - ◀ Readjust (reduce) the idling speed if the cutting disc doesn't stop rotating when the engine is idling. If this is not possible, please bring the product to **Hilti Service**.
2. Check that the start/stop switch is functioning correctly. Move the start/stop switch to the “stop” position.
3. If the following equipment exists, also take this action:

DSH 600

- ▶ If the engine doesn't stop, push the choke lever upwards. If the engine still doesn't stop, pull the spark plug connector off the spark plug and bring the product to **Hilti Service**.

4. If the following equipment exists, also take this action:

DSH 600-X

- ▶ If the engine doesn't stop, compress the primer bulb. If the engine still doesn't stop, pull the spark plug connector off the spark plug and bring the product to **Hilti Service**.

6.3 Switching the engine off

WARNING

Risk of injury. A rotating cutting disc can break or shatter, possibly resulting in flying fragments.

- ▶ Allow the rotating cutting disc to come to a complete standstill before you lay the saw down.

1. Release the throttle trigger.
2. Move the start/stop switch to the “stop” position.
 - ◀ The engine stops.

6.4 Cutting techniques

WARNING!

In order to work optimally with this tool, the following safety instructions must be observed:

- ▶ Always hold the tool with both hands on the grips provided. Keep the grips dry, clean and free from oil and grease.
- ▶ Before beginning the work, or if the disc has inadvertently come into contact with an obstacle (e.g. a concealed object), check the cutting disc and guard immediately for possible damage.
- ▶ Check that no persons are present in the working area and, in particular, in the direction in which the cut is to be made. Keep other persons approx. 15 m away from your workplace.
- ▶ Guide the tool smoothly and do not apply lateral pressure to the cutting disc.
- ▶ Avoid hazardous operating positions.
- ▶ Always bring the cutting disc into contact with the workpiece at right angles. Do not attempt to alter the line of cut by applying lateral pressure or by bending the cutting disc while cutting is in progress.
- ▶ Secure the workpiece. Use clamps or a vice to hold the workpiece in position. The workpiece is thus held more securely than by hand and both hands remain free to operate the tool.
- ▶ Clamp round workpieces so that they cannot rotate.
- ▶ Do not cut several workpieces at the same time. Cut them one after the other.
- ▶ Secure the workpiece and the part to be cut off in order to prevent uncontrolled movement.
- ▶ Always apply full throttle when cutting.

Avoiding sticking / stalling of the cutting disc

WARNING

Risk of bruising or other injuries. Sticking / stalling of the cutting disc in the kerf may cause the saw to be pulled forward, to climb or cause kickback.

- ▶ Take care to avoid sticking / stalling of the cutting disc while cutting.

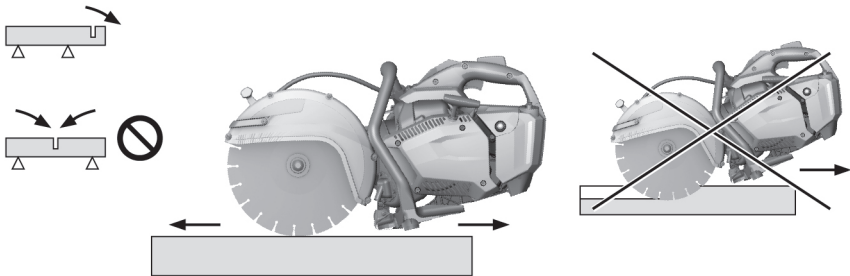

Reasons for the cutting disc sticking / stalling:

- The cut is too deep.
- The kerf becomes narrower (e.g. when cutting pipes or slabs).
- The cutting disc is tilted.
- An unsuitable cutting disc is used (the cutting disc becomes clogged).
- The cutting disc is inserted too quickly in an existing kerf.

Hazardous situations that may be caused depending on the working position and sticking / stalling

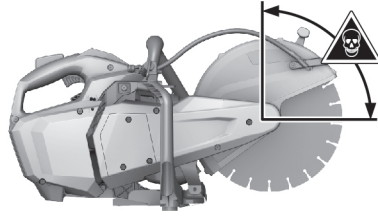

- Pulling may occur when making horizontal cuts (e.g. in a floor). The saw may suddenly pull forwards, possibly pulling it out of the operator's hands.
- Climbing may occur when making vertical cuts (e.g. in a wall). The saw may suddenly pull upwards, possibly pulling it out of the operator's hands.
- Kickback may occur if the prohibited area of the disc is brought into contact with the workpiece.

Avoiding hazardous situations resulting from sticking / stalling of the cutting disc:

- ▶ Cutting through thick workpieces should be accomplished, as far as possible, by making several cuts. Avoid making excessively deep cuts.
- ▶ Support slabs or large workpieces so that the kerf remains open during and after the cutting operation.
- ▶ Always bring the cutting disc into contact with the workpiece from above.
 - ◀ Allow the cutting disc to contact the workpiece only at a point below its rotational axis.
- ▶ Be particularly cautious when inserting the cutting disc in an existing kerf.
- ▶ Take care to avoid tilting the cutting disc to the side.

7 Care and maintenance

⚠ WARNING

Risk of injury. Touching the rotating cutting disc or hot parts of the machine may lead to injury or burns.

- ▶ Switch the engine off and allow the product to cool down before all maintenance, repairs, cleaning or servicing.

7.1 Maintenance table

1 - Before starting work | 2 - Every six months | 3 - As necessary

	1	2	3
Check that the tool is complete, in perfect condition and free of leaks. Have it repaired if necessary.	X		
Check for dirt and foreign matter. Clean if necessary.	X		
Check that the controls function correctly. Have repairs carried out if necessary.	X		
Check that the cutting disc is in perfect condition. Replace if necessary.	X		
Check that all externally accessible nuts and screws are securely tightened.	X	X	X
Check that the fuel filter is clean. Replace it if necessary.		X	X
Replace the air filter if the product does not start or engine performance fades noticeably.			X
Clean or replace the spark plug if the product does not start or is difficult to start.			X
Adjust the idling speed if the cutting disc does not slow to a standstill when the engine is idling.			X
Have the product repaired by Hilti Service if the drive belt slips when a load is applied to the cutting disc.			X

7.2 Cleaning or replacing the air filter

ATTENTION

Risk of damage. Entry of dust causes irreparable damage to the product.

- ▶ Never operate the machine if the air filter is damaged or missing.
- ▶ When changing the air filter, the product should stand upright and should not be laid on its side. Take care to ensure that no dust finds its way onto the underlying filter screen.

Change the air filter if engine performance drops noticeably or if the engine becomes difficult to start.

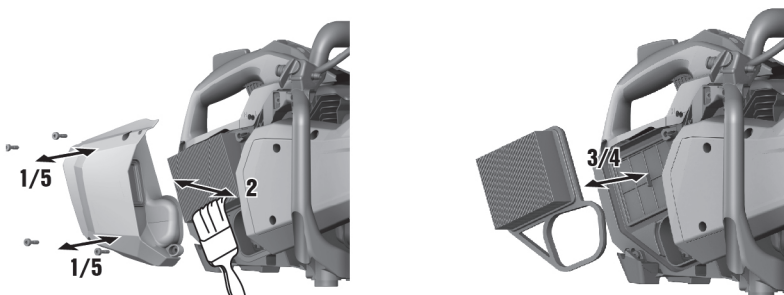

1. Release the securing screw on the air filter cover and remove the cover.
2. Carefully remove the dust adhering to the air filter and the filter chamber (use a vacuum cleaner).
3. Release the four screws retaining the filter holder and remove the air filter.
4. Fit the new filter and secure it with the filter holder.
5. Fit the air filter cover and tighten the retaining screws.

7.3 Replacing a broken starter cord

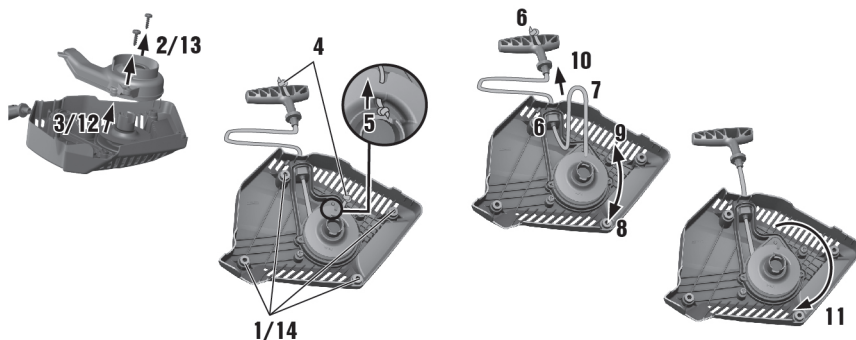

CAUTION

Risk of damage. The housing may suffer damage if the starter cord is too short.

- ▶ Never continue to use a broken starter cord. Replace it immediately.
1. Release the four securing screws and remove the starter assembly.
 2. Release the two screws securing the cover and remove the cover.
 3. Remove the remains of the broken starter cord from the spool and the pull handle.
 4. Securely knot one end of the replacement starter cord and from above, pass the other end of the cord through the hole in the spool.

5. From below, pass the end of the cord through the hole in the starter housing and from below through the pull handle, and securely knot the end of the cord.
6. Pull a length of the starter cord out of the housing as shown in the illustration and pass it through the slot in the spool.
7. Hold the cord securely close to the slot in the spool and turn the spool clockwise as far as it will go.
8. Back the spool off at least $\frac{1}{2}$ to max. $1\frac{1}{2}$ turns, until the slot in the spool is in alignment with the opening in the starter housing.
9. Hold the spool securely and pull the cord out of the housing toward the pull handle.
10. Hold the cord taut, release the spool and allow the starter cord to be pulled in.
11. Pull the starter cord out as far as it will go and check that the spool can be turned by hand at least a further $\frac{1}{2}$ turn clockwise. If this is not possible, spring tension must be reduced by turning the spool one full turn counterclockwise.
12. Install the cover and secure it with the two securing screws.
13. Place the starter assembly in position and carefully press it down. Pull the starter cord slightly until the coupling engages and the starter assembly is fully seated.
14. Secure the starter assembly with the four securing screws.

7.4 Replacing the fuel filter



When refueling the product, take care to ensure that no dirt or foreign matter finds its way into the fuel tank.

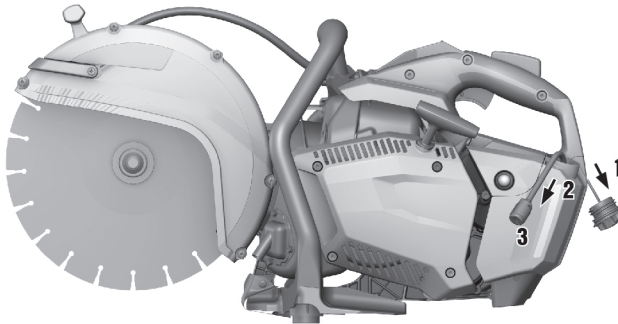

1. Remove the cap from the fuel tank.
2. Pull the fuel filter out of the fuel tank.
3. Check the condition of the fuel filter.
 - ◀ Replace the fuel filter if it is very dirty or clogged.
4. Slide back the clip on the hose and remove the dirty fuel filter.
5. Fit a new fuel filter and secure it with the clip on the hose.
6. Push the fuel filter back into the fuel tank.
7. Close the fuel tank.

7.5 Cleaning the spark plug, setting the spark plug gap or replacing the spark plug



CAUTION

Risk of injury. The spark plug and parts of the engine may be hot immediately after the product has been in use.

- ▶ Wear protective gloves and allow the product to cool down.

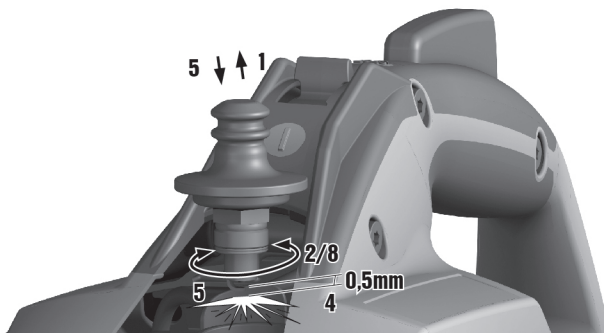

1. Use a gentle twisting motion to pull the cable connector off the spark plug.
2. Use the spark plug wrench to unscrew and remove the spark plug from the cylinder.
3. If necessary, clean the spark plug electrode with a soft wire brush.
4. Check the spark plug gap with the aid of a feeler gauge and, if necessary, reset it to the correct gap (0.5 mm).
5. Fit the ignition cable connector to the spark plug and hold the threaded section of the spark plug against the cylinder.
6. Move the start/stop switch to the “start” position.

WARNING

Risk of injury. Touching the electrodes presents a risk of electric shock.

- ▶ Don't touch the spark plug electrodes.

7. Pull the starter handle.
 - ◀ An ignition spark must now be clearly visible.
8. Use the spark plug wrench to screw the spark plug into the cylinder (tightening torque: 12 Nm).
9. Fit the ignition cable connector to the spark plug.

7.6 Adjusting the carburetor

The carburetor of this product has been factory set for optimum performance and sealed to prevent tampering (jets H and L). The idling speed of the machine (jet T) may be adjusted by the user. All other adjustments must be carried out by **Hilti** Service.



Tampering with the carburetor settings may cause damage to the engine.

- ▶ Clean the air filter. → page 21
- ▶ Allow the product to run until it reaches its normal operating temperature.

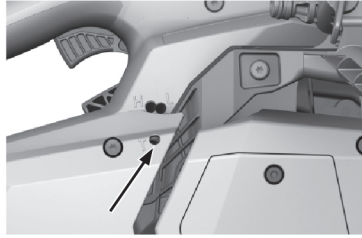

- ▶ Use a suitable flat screwdriver (tip width 4 mm/ $\frac{5}{32}$ ") and do not force the adjusting screw beyond its intended adjustment range.
- ▶ Adjust the idling speed jet (T) so that the engine runs smoothly when idling but the cutting disc does not begin to rotate.

7.7 Cleaning the water nozzles

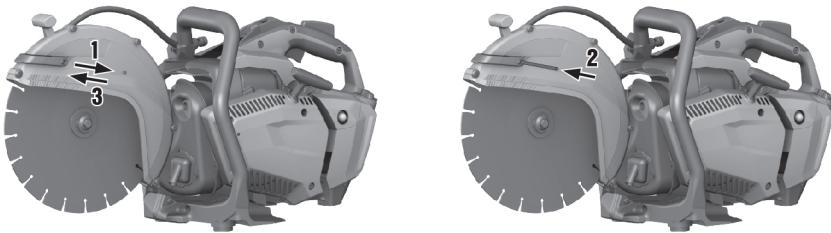

1. Remove the cleaning screw on the curved water distributor.
2. Use a wire to clean the water nozzles.
3. Fit the cleaning screw.

7.8 Care of the product

i To help ensure safe and reliable operation, use only genuine Hilti spare parts and consumables. Spare parts, consumables and accessories approved by us for use with the product can be found at your local **Hilti Center** or online at: www.hilti.com

- ▶ Keep the product, especially its grip surfaces, clean and free from oil and grease.
- ▶ Do not use cleaning agents containing silicone.
- ▶ Clean the outer surfaces of the machine at regular intervals with a slightly damp cloth or a dry brush. Do not use a spray, steam pressure cleaning equipment or running water for cleaning.
- ▶ Do not allow foreign objects to enter the interior of the product.

7.9 Maintenance

1. Check all external parts of the product and the accessories for damage at regular intervals and check that all controls operate faultlessly.
2. Do not use the product if parts are damaged or if operating controls do not function faultlessly. Have the product repaired by **Hilti Service**.

7.10 Checks after care and maintenance work

- ▶ After carrying out care and maintenance, check that all protective and safety devices are fitted and that they function faultlessly.

8 Transport and storage

8.1 Transporting the product in a vehicle

DANGER

Risk of fire and explosion. If the product tips over during transport, fuel may run out of the fuel tank.

- ▶ Empty the product's fuel tank completely before packing and shipping it.
- ▶ Transport the product, as far as possible, in its original packaging.

WARNING

Fire hazard. Hot parts of the machine could ignite material lying about in the surrounding area.

- ▶ Allow the product to cool down completely before packing it away or loading it into a vehicle..

1. Remove the cutting disc.
2. Secure the product to prevent it falling over, thereby causing damage or fuel spillage.

8.2 Storing the fuel mixture

CAUTION

Risk of injury. As pressure may build up in the fuel tank there is a risk of fuel being forced out when the fuel cap is opened.

- ▶ Accordingly, take care when opening the cap on the fuel tank.
- ▶ Store the fuel in a dry, well-ventilated room.

1. Mix only enough fuel for a few days' use.
2. Clean the fuel container occasionally.

9 Troubleshooting

If the trouble you are experiencing is not listed in this table or you are unable to remedy the problem by yourself, contact **Hilti Service**.

Trouble or fault	Possible cause	Action to be taken
Cutting disc slows down or stops completely while cutting	Excessive cutting pressure applied (cutting disc sticks and stalls in the kerf).	▶ Reduce pressure when cutting and guide the product in a straight line.
	The cutting disc is not correctly fitted and tightened.	▶ Check how it is fitted and the tightening torque.
	Wrong direction of rotation.	▶ Fit the cutting disc. → page 12
	The forward section of the saw arm is loose.	▶ Have the product repaired by Hilti Service .
High vibration, disc wanders off the cutting line.	The cutting disc is not correctly fitted and tightened.	▶ Check how it is fitted and the tightening torque.
	Cutting disc is damaged (or unsuitable specification, cracked, segments missing, bent, overheated, deformed, etc.).	▶ Change the cutting disc.
	The centering bushing is fitted incorrectly.	▶ Check that the mounting bore of the cutting disc to be fitted corresponds with the centering collar of the cutting disc mounting flange.

Trouble or fault	Possible cause	Action to be taken
The diamond cutting disc swings up and may jam.	Diamond cutting disc does not fit correctly	▶ Use Hilti cutting discs.
	Flange for diamond cutting disc does not fit correctly	▶ With cutting discs made by competitors, use the flange for abrasive cutting discs.
The saw doesn't start or is difficult to start.	The fuel tank is empty (no fuel in the carburetor).	▶ Fill the fuel tank. → page 12
	Air filter clogged with dirt or dust.	▶ Change the air filter.
	DSH 600 The engine is flooded (spark plug wet).	▶ Remove the spark plug, dry the plug and allow the cylinder to dry out. ▶ Disengage the choke lever and repeat the starting procedure several times.
	DSH 600-X The engine is flooded (spark plug wet).	▶ Remove the spark plug, dry the plug and allow the cylinder to dry out.
	Wrong fuel mixture.	▶ Empty the fuel tank and flush out the tank and fuel supply line. ▶ Fill the fuel tank with the correct fuel.
	Air in the fuel line (no fuel reaching the carburetor).	▶ Remove the air from the fuel line by operating the fuel pump several times.
	The fuel filter is dirty or blocked (no fuel or too little fuel reaching the carburetor).	▶ Clean the fuel tank and change the fuel filter.
	No ignition spark visible or spark is too weak (seen when spark plug is removed).	▶ Clean the spark plug to remove carbon deposits. ▶ Check the spark plug electrode gap and set it correctly. ▶ Change the spark plug. ▶ Check the ignition coil, cable, plug connections and switch and change the defective part if necessary.
	Engine compression is too low.	▶ Check the engine compression and, if necessary, replace worn parts (piston rings, piston, cylinder, etc.).
	The ambient temperature is too low.	▶ Allow the saw to warm up to room temperature and repeat the starting procedure.
The spark arrestor or exhaust exit is clogged.	▶ Clean the spark arrestor or exhaust exit.	
Low engine power / poor cutting performance	Air filter clogged with dirt or dust.	▶ Change the air filter.
	No ignition spark visible or spark is too weak (seen when spark plug is removed).	▶ Clean the spark plug to remove carbon deposits. ▶ Check the spark plug electrode gap and set it correctly. ▶ Change the spark plug. ▶ Check the ignition coil, cable, plug connections and switch and change the defective part if necessary.

Trouble or fault	Possible cause	Action to be taken
Low engine power / poor cutting performance	Wrong fuel mixture.	<ul style="list-style-type: none"> ▶ Empty the fuel tank and flush out the tank and fuel supply line. ▶ Fill the fuel tank with the correct fuel.
	The disc specification is unsuitable for the material to be cut.	▶ Change the cutting disc or ask Hilti Service for advice.
	Drive belt or cutting disc slips.	<ul style="list-style-type: none"> ▶ Check that the cutting disc is clamped securely. ▶ Have the product repaired by Hilti Service.
	Engine compression is too low.	▶ Check the engine compression and, if necessary, replace worn parts (piston rings, piston, cylinder, etc.).
	The product is used at an altitude greater than 1500 meters above sea level.	▶ Have the carburetor adjusted by Hilti Service .
	Incorrect carburetor setting (fuel / air mixture).	▶ Have the carburetor adjusted by Hilti Service .
Cutting disc rotates while the engine is idling.	Idling speed is too high.	▶ Check the idling speed and adjust it if necessary.
	The half-throttle position is engaged.	▶ Release the half-throttle position.
	Faulty centrifugal clutch.	▶ Change the centrifugal clutch.
Cutting disc doesn't rotate.	Inadequate drive belt tension or the drive belt is broken.	▶ Have the product repaired by Hilti Service .
Starter assembly doesn't work.	The clutch claws are not engaging.	▶ Clean the clutch claws so that they move freely.
<div style="background-color: #cccccc; padding: 2px;">DSH 600-X</div> <p>Saw blade rotates for longer than 15 seconds after the throttle safety grip is released.</p>	Brake strap is worn.	▶ Have the product repaired by Hilti Service .
	Action of Bowden cable for brake is stiff.	▶ Have the product repaired by Hilti Service .

10 Disposal

Most of the materials from which **Hilti** products are manufactured can be recycled. The materials must be correctly separated before they can be recycled. In many countries, your old tools, machines or appliances can be returned to **Hilti** for recycling. Ask **Hilti Service** or your **Hilti** representative for further information.

Drilling slurry

Disposal of drilling slurry directly into rivers, lakes or the sewerage system without suitable pretreatment presents environmental problems.

- ▶ Ask the local public authorities for information about current regulations.

We recommend the following pretreatment:

- ▶ Collect the drilling slurry (for example, using a wet-type vacuum cleaner).
- ▶ Allow the drilling slurry to settle and dispose of the solid material at a construction waste disposal site (addition of a flocculent may accelerate the settling process).
- ▶ The remaining water (alkaline, pH value greater than 7) must be neutralized by the addition of an acidic neutralizing agent or diluted with a large volume of water before it is allowed to flow into the sewerage system.

11 Manufacturer's warranty

- ▶ Please contact your local **Hilti** representative if you have questions about the warranty conditions.

11.1 Federal emission control warranty statement

Your warranty rights and obligations

The U.S. Environmental Protection Agency (EPA), the California Air Resources Board (CARB), and **Hilti** are pleased to explain the Emission Control System Warranty applicable to your small non-road engine. In U.S. and Canada, small non-road engines must be designed, built and equipped to meet the stringent federal antismog standards. The equipment engine must be free from defects in materials and workmanship which cause it to fail to conform with U.S. EPA standards for the first two years from the date of sale to the ultimate purchaser. **Hilti** must warrant the emission control system on your small non-road engine for the periods of time listed above, provided there has been no abuse, neglect or improper maintenance of your unit. Your emission control system includes parts such as the carburetor and the ignition system. Where a warrantable condition exists, **Hilti** will repair at no cost to you. Expenses covered under warranty include diagnosis, parts and labor.

Manufacturer's warranty coverage

All 2001 and later small non-road engines are warranted to meet the applicable EPA and CARB requirements for two years. If any emission related part on your engine (as listed above) is defective, the part will be repaired or replaced by **Hilti**.

Owner's warranty responsibilities

As a small non-road engine owner, you are responsible for performance of the required maintenance as defined by **Hilti** in the owner's manual. **Hilti** recommends that you retain all receipts covering maintenance on your small non-road engine, but **Hilti** cannot deny warranty solely for the lack of receipts or for your failure to ensure the performance of all scheduled maintenance. Any replacement part or service that is equivalent in performance and durability may be used in non-warranty maintenance or repairs, and shall not reduce the warranty obligations of the engine manufacturer. As the small non-road equipment owner, you should be aware, however, that **Hilti** may deny you warranty coverage if your small non-road engine or a part of it has failed due to abuse, neglect, improper maintenance, unapproved modifications or the use of parts not made or approved by the original equipment manufacturer. You are responsible for presenting your small non-road engine to **Hilti** as soon as the problem exists. The warranty repairs should be completed in a reasonable amount of time, not to exceed 30 days.

Coverage

Hilti warrants to the ultimate purchaser and each subsequent purchaser that your small non-road equipment engine will be designed, built equipped, at the time of sale, to meet all applicable regulations. **Hilti** also warrants to the initial purchaser and each subsequent purchaser that the emission-related warranted parts are free from defects in material and workmanship which cause the engine to fail to conform with applicable regulations for a period of two years. These warranty periods will begin on the date small non-road equipment engine is purchased by the initial purchaser. If any emission-related part on your engine is defective during this warranty period, the part will be replaced by **Hilti** at no cost to the owner. **Hilti** shall remedy warranty defects at authorized **Hilti** service and repair centers. Any authorized work done at an authorized **Hilti** service and repair center shall be free of charge to the owner if it is determined that a warranted part is defective. Any manufacturer-approved or equivalent replacement part may be used for any warranty maintenance or repairs on emission-related parts, and must be provided free of charge to the owner if the part is still under warranty. **Hilti** is liable for damages to other engine components caused by the failure of a warranted part still under warranty. The California Air Resources Board's Emission Warranty Part List specifically defines the emission related, warranted parts. These warranted parts are: the carburetor assembly, coil assembly, rotor, spark plug, air filter, fuel filter, breather manifold and the gaskets.

Maintenance requirements

The owner is responsible for performing the required maintenance as defined by **Hilti** in the owner's manual.

Limitations

The Emission Control Systems Warranty shall not cover any of the following: a) repair or replacement required because of misuse, neglect or lack of required maintenance, b) repairs improperly performed or replacements not conforming to **Hilti** specifications that adversely affect performance and/or durability, and alterations or modifications not recommended or approved in writing by **Hilti**, and c) replacement of parts and other services and adjustments necessary for required maintenance at and after this first scheduled replacement point. Except as set forth above, the warranty terms set forth in section 12 below, apply.

11.2 Manufacturer's warranty

Hilti warrants that it will repair or replace any part containing a defect in material and workmanship for 20 years from the original sale date. This warranty is valid so long as the tool is operated and handled correctly, cleaned and serviced properly and in accordance with the **Hilti** Operating Instructions, and the technical

system is maintained. This means that only original **Hilti** consumables, components and spare parts may be used in the tool.

This warranty provides the free-of-charge repair or replacement of defective parts only over the entire lifespan of the tool. Parts requiring repair or replacement as a result of normal wear and tear are not covered by this warranty.

Additional claims are excluded, unless stringent national rules prohibit such exclusion. In particular, Hilti is not obligated for direct, indirect, incidental or consequential damages, losses or expenses in connection with, or by reason of, the use of, or inability to use the tool for any purpose. Implied warranties of merchantability or fitness for a particular purpose are specifically excluded.

For repair or replacement, contact **Hilti** immediately upon discovery of the defect at:

In the USA:

800.879.8000

Hilti Inc.

7250 Dallas Parkway, Suite 1000

Plano, TX 75024

CS.InboundUS@hilti.com

In Canada:

800.343.4458

Hilti (Canada) Corporation

2360 Meadowpine Blvd

Mississauga, ON L5N 6S2

CanadaSalesSupport.English@hilti.com

CanadaSalesSupport.French@hilti.com

This constitutes **Hilti**'s entire obligation with regard to warranty and supersedes all prior or contemporaneous comments and oral or written agreements concerning warranties.

This Product is Certified
Ce produit est homologué
Producto homologado por
Este producto está registrado





Hilti Corporation
LI-9494 Schaan
Tel.: +423 234 21 11
Fax: +423 234 29 65
www.hilti.com



2164701



Hilti Connect