

CATSKILL

C R A F T S M E N , I N C .



Model 7227

GENERAL:

1. You have purchased model 7227. Overall dimensions of an assembled unit is 32 3/4" x 21" x 35 1/2" when drop leaf is down.
2. Should you need assistance or need to replace a damaged or missing part, DO NOT RETURN THE UNIT TO THE STORE where you purchased it, simply give us a call at 607-652-7321 from 7:30 - 4:00 PM Eastern time and we'll send you the prepaid part via UPS usually that same day!
3. Read the assembly instructions and the enclosed brochure before beginning assembly. Assembly is very easy if you read and follow the instructions step by step.
4. Tools required: Phillips screwdrivers, medium and small; medium flat blade screwdriver, pliers and a hammer.

CABINET PARTS

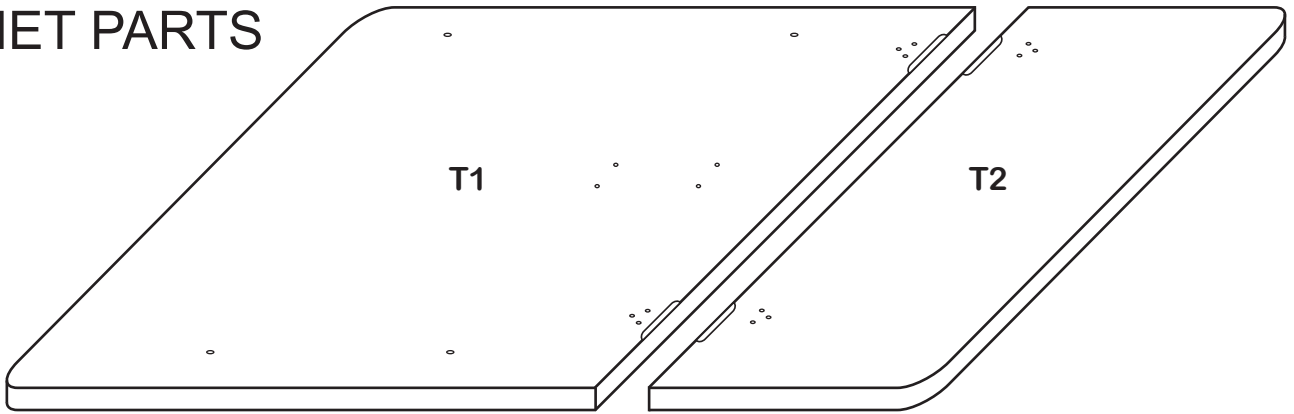

Cart Top P/N TT-7227 (1)

Drop Leaf P/N DL-7227 (1)

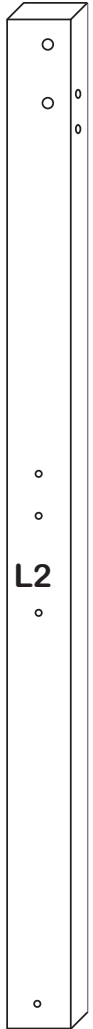

Left Leg
P/N L7227L

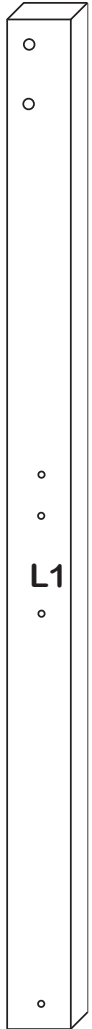

Right Leg
P/N R7227R

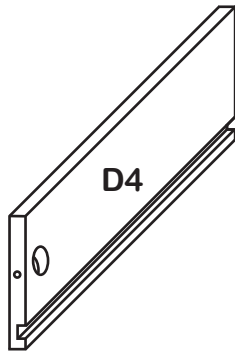

Drawer Side/Left P/N DS-7227/L

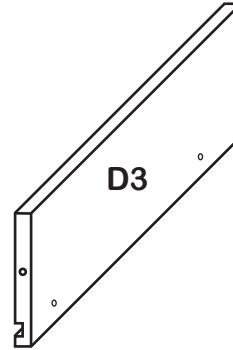

Drawer Side/Right P/N DS-7227/R

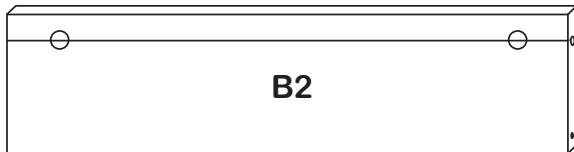

Top Back Brace P/N B-15 7/8-5 3/4-TBK (1)



Drawer Back P/N DBK-7227 (1)

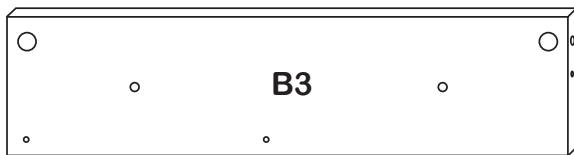

Top Left Brace P/N B-15 7/8-5 3/4-TS-7227 (1)

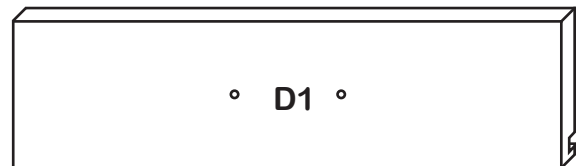

Drawer Front P/N DF-7227 (1)

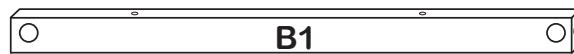

Top Front Brace P/N B-15 7/8-1 1/4-TF (1)

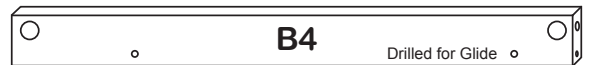

Top Right Side Brace P/N B-15 7/8-TRS-7227 (1)

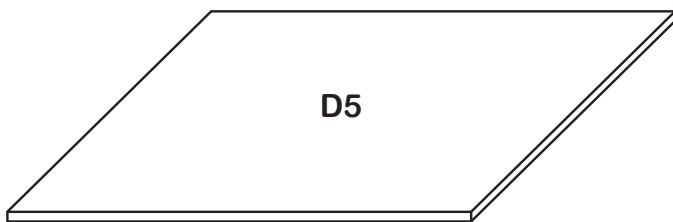

Drawer Bottom P/N DB-7227 (1)

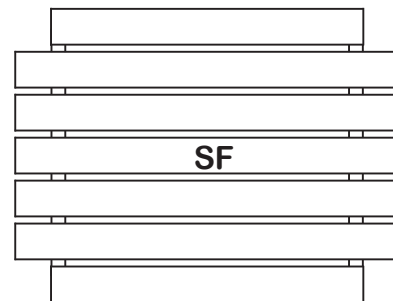

Shelf P/N B SS-7227 (2)

HARDWARE

 1 3/4" Phillips Flat Head Bolt (4)

 1 3/4" Phillips Flat Head #8 Screw (2)

 1 1/4" Phillips Flat Head #8 Screw (14)

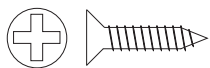
 5/8" Phillips Flat Head #8 Screw (18)

 (Used on Cabinet Side Glides)
5/8" Phillips Flat Head #6 Screw (4)

 (Used on Drawer Side Glides)
5/8" Phillips Flat Head #5 Screw (4)

 3/4" Truss Head Machine Screw (2)

 3/4" Long 3/16" DIA. Steel Pin (6)

 10-24 Hex Nut (4)

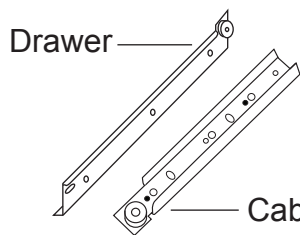
Drawer — Cabinet
Drawer Glide (2 Sets)

The glides look almost alike however, the right glide (as you face the cart) has a rolled lip at the top of the glide that keeps the drawer glide wheel in place.

 "Z" Bracket (2)

 5/8" Wooden Disk (4)

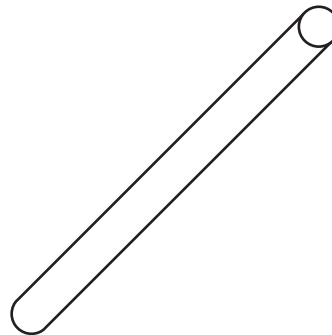
 Polished Nickel Towel Bar (1)

 Towel Bar Post (2)

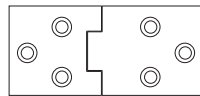
 Hinge (2)

 Handle (1)

 P/N Drop Leaf Support (1)

 Bastion Post (6)

 Bastion Set Screw (6)

 Bastion Barrel Nut (6)

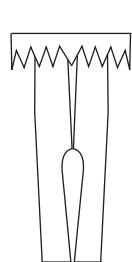
 Caster Socket (4)

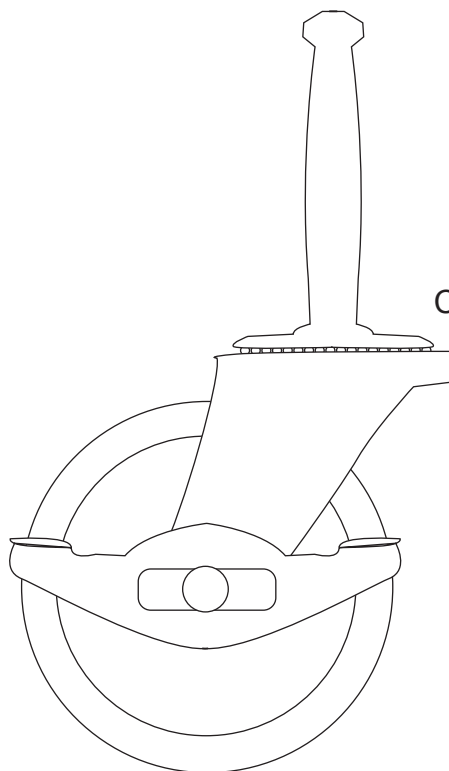
 Locking Wheel Casters (2)

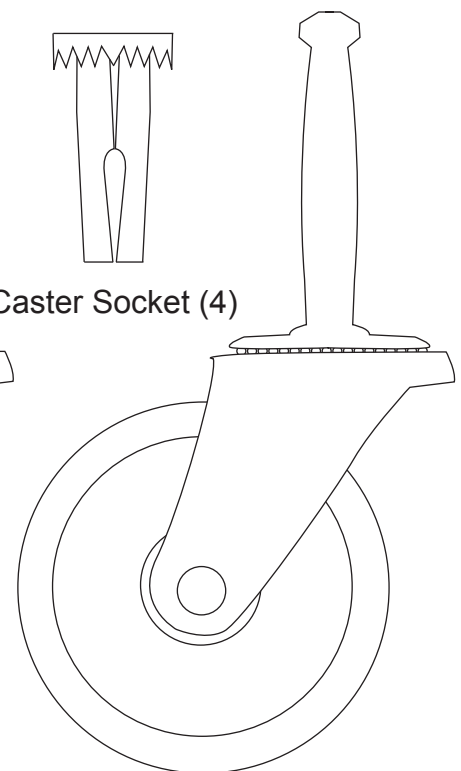
 Wheel Casters (2)

STEP 1

Drawer Assembly:

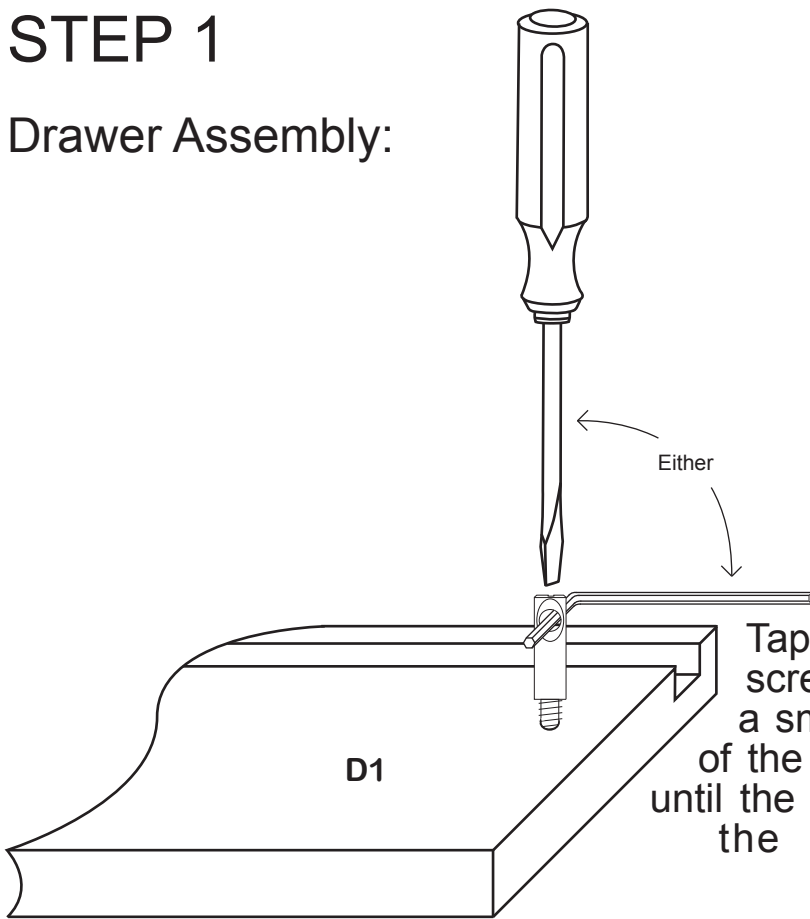

Tap in post with a hammer to start and screw down with a screwdriver or with a small allen wrench until the shoulder of the post hits the wood. Then unscrew until the hole is parallel with the groove on the bottom of the Drawer Front.

To understand how the bastion fastening system works see next page.

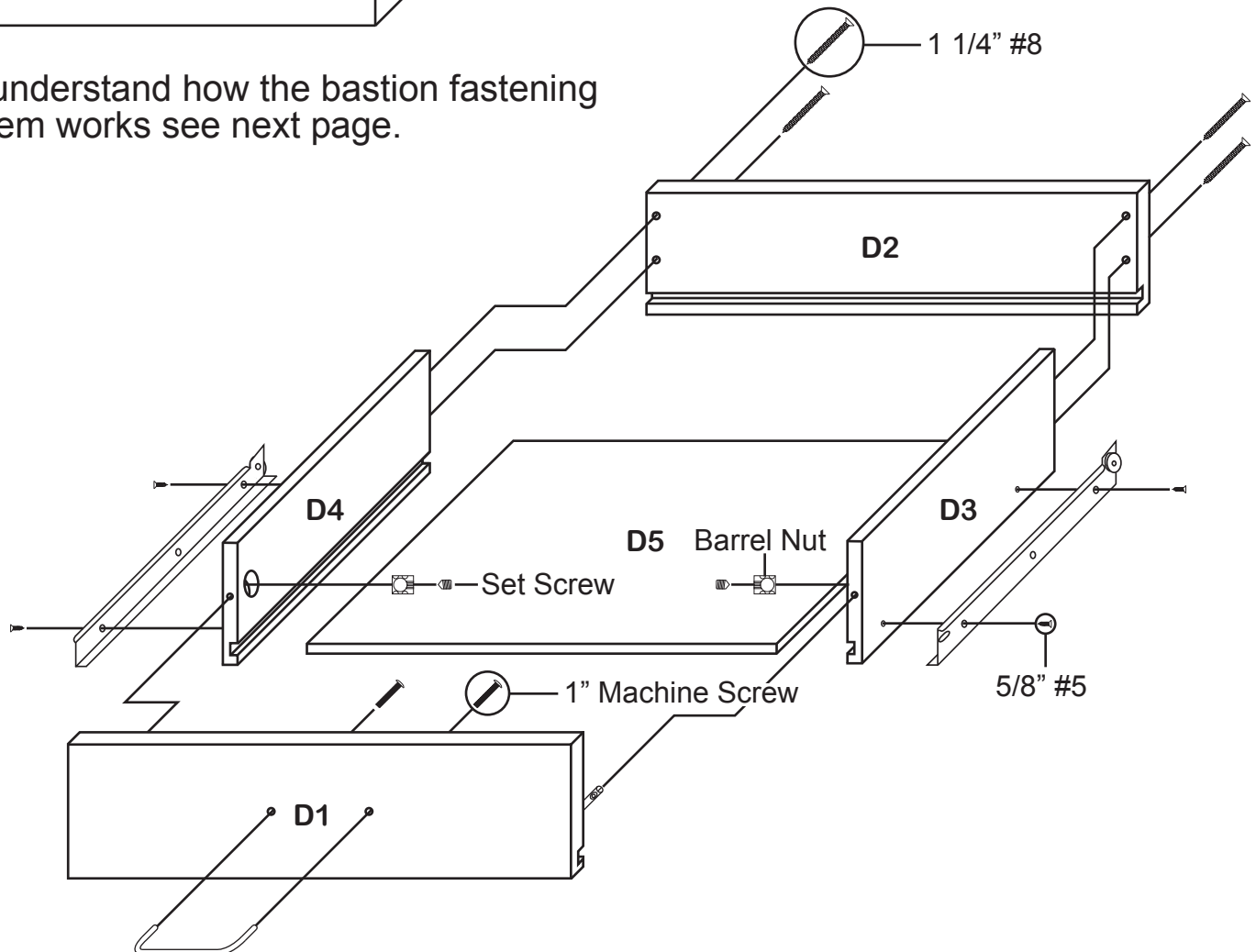

TIPS ON HOW THE BASTION FASTENING SYSTEM WORKS

1. The Bastion fastening system consists of a steel post (threaded on one end with a hole through the shaft on the other end); a Barrel Nut (cylindrical barrel-shaped with threaded open end & holes through the sides); and a Set Screw (Phillips slot on one end, pointed on the other)

2. To attach Posts: A) Dip threads of Post in vegetable oil. B) Align threaded end of Post with hole in wood, tap on slotted end with hard hammer until threads enter, then tighten down using a flat head screw driver or the provided allen wrench (See the Illus. Bas. 3 for alternate seating methods). **DO NOT TRY TO HAMMER THE POST ALL THE WAY IN AS IT WILL STRIP THE POST HOLE.** C) When solid shaft of Post hits wood, back out approximately 1/2 turn until the hole in the posts is properly aligned as per step by step directions. For example: the holes in the posts on the inside of the drawer front will be parallel with the long length of the drawer front when properly seated.

3. A) Place a Barrel Nut into the nut access hole, so that the threads in the nut face out. The small notches on either side of the nut opening, indicate the location of the holes through the sides of the nut. B) Insert the posts through the end of the braces (or drawer sides); through the holes in the sides of the nut. When properly aligned, you will see the hole in the post inside the barrel nut. Post hole should be slightly off-center toward the wood.

4. Insert the Set Screw into the threaded end of the nut and tighten down. The tip of the Set Screw will seek the center of the hole in the Post as it is tightened down, forcing the Nut toward the main shaft of the Post. This is what tightens the wooden parts together. Set screws should thread easily – **DON'T CROSS THREAD!** If Set Screw doesn't thread easily, check position of the hole in Post.

5. If the wooden parts are not tight against each other, the Post needs to be screwed a half turn at a time until wood joints are tight.

Illustration Bas. 1

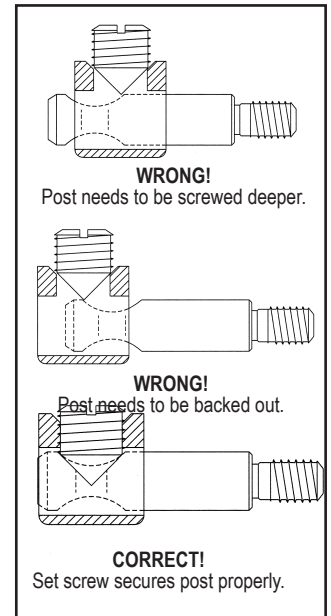

Step 1

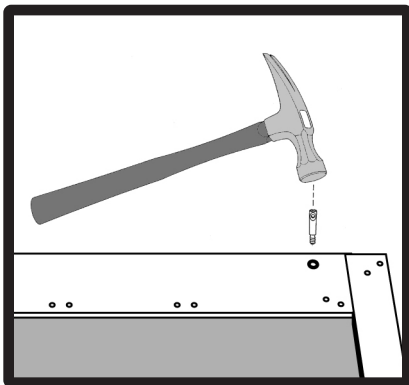
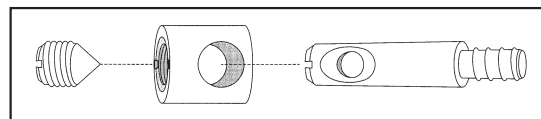

Illustration Bas. 2



Step 2

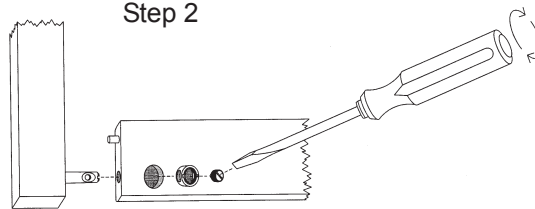
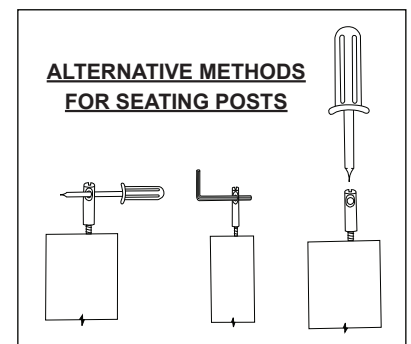

Illustration Bas. 3



If you have any questions regarding assembly or missing or damage parts, call our customer support number:

607-652-7321 or 888-732-7321.

Customer Support hours are 8am-4pm Mon. - Fri. Eastern Time zone.

STEP 2

Top Assembly:

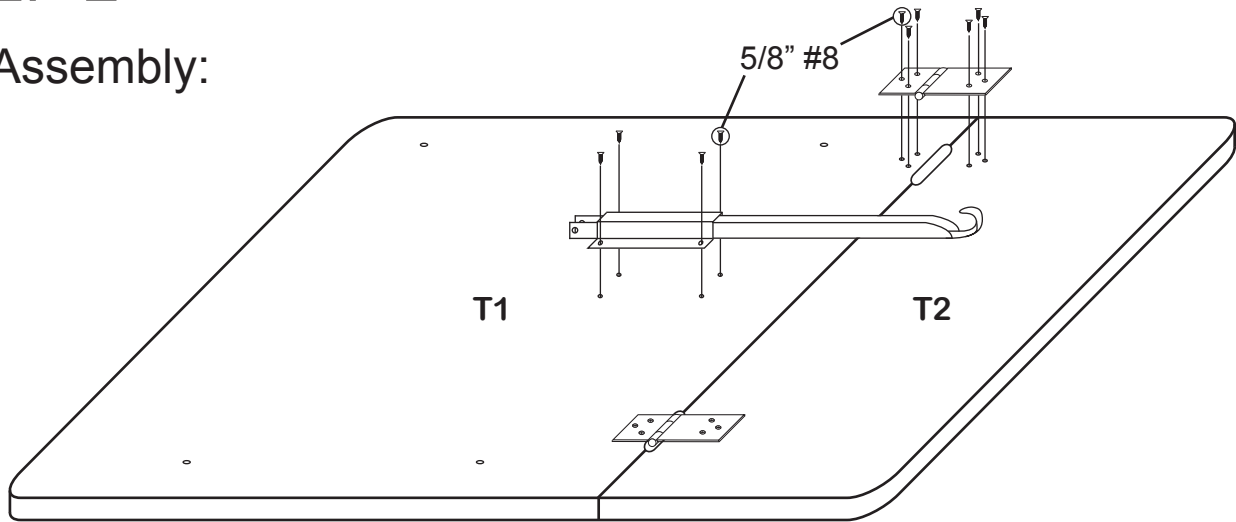

STEP 3

Brace Preparation:

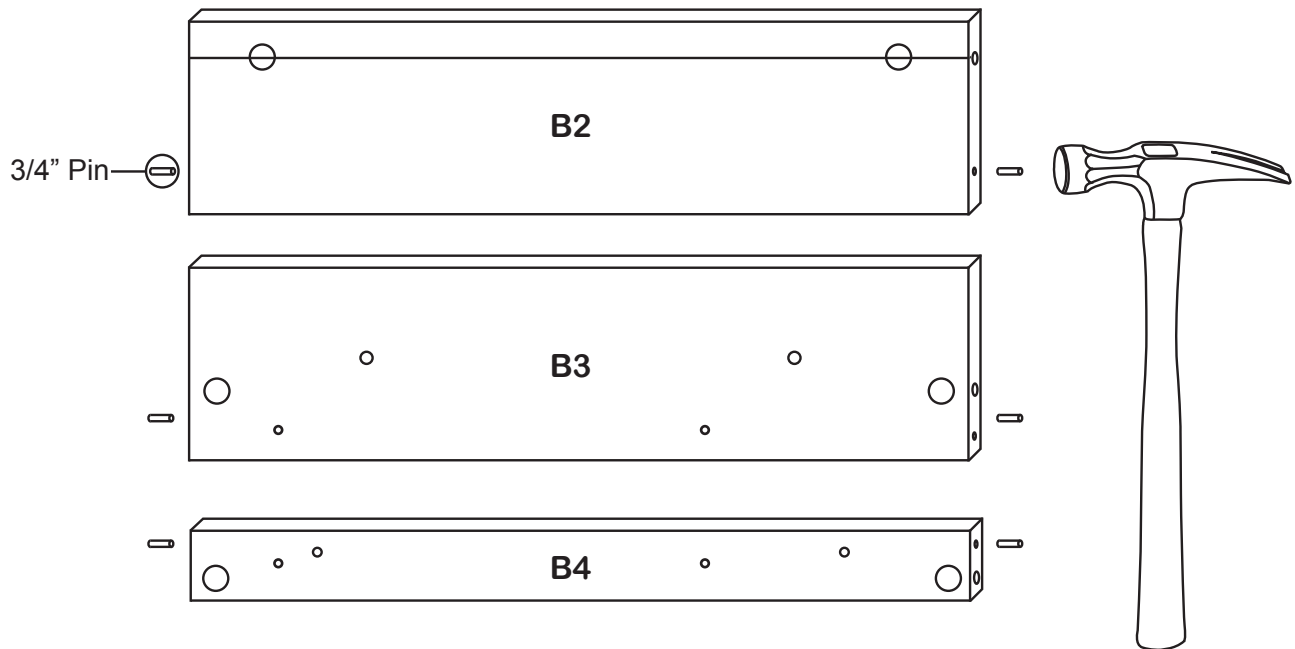

STEP 4

Left Side Assembly:

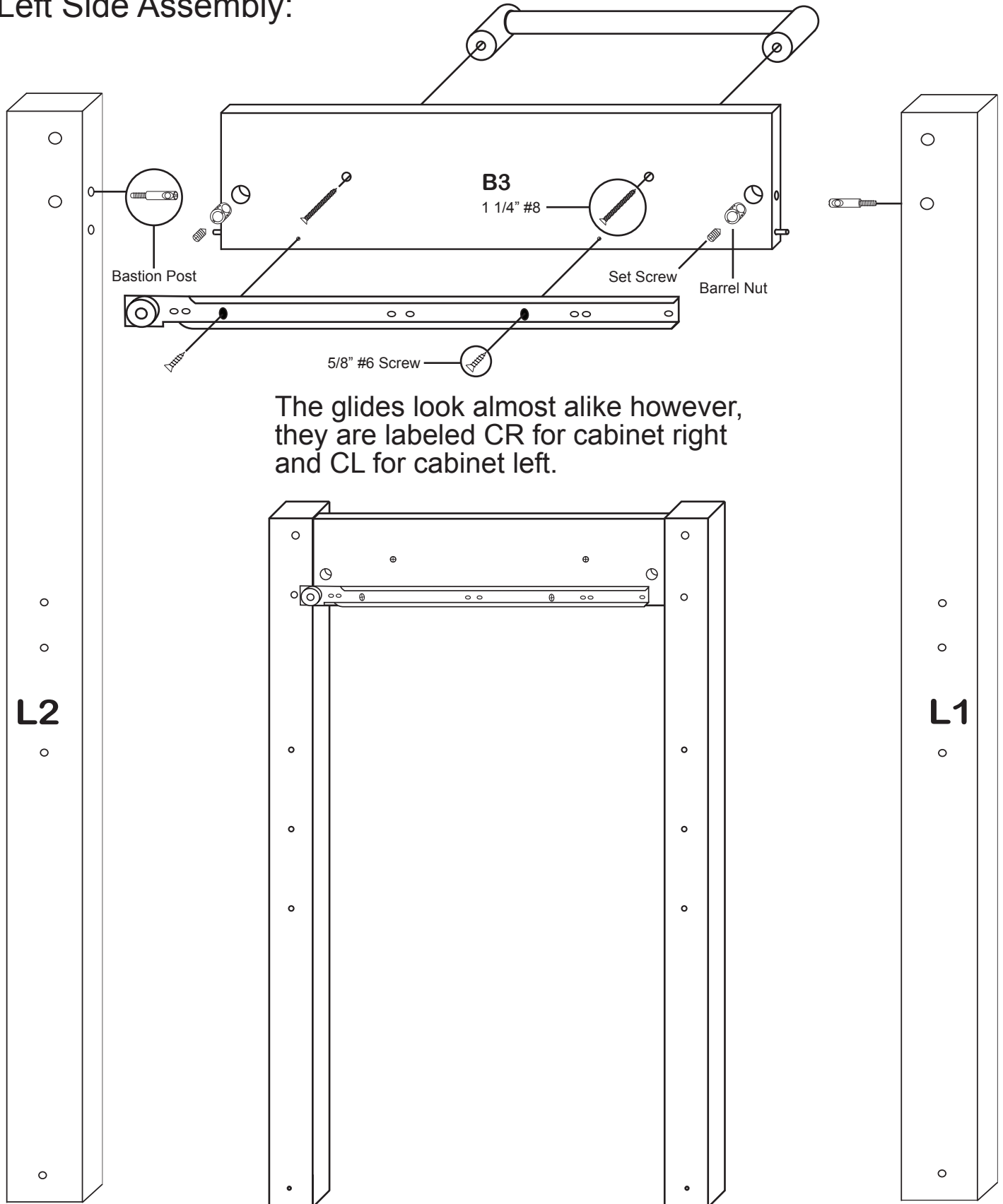

The glides look almost alike however, they are labeled CR for cabinet right and CL for cabinet left.

STEP 5

Right Side Assembly:

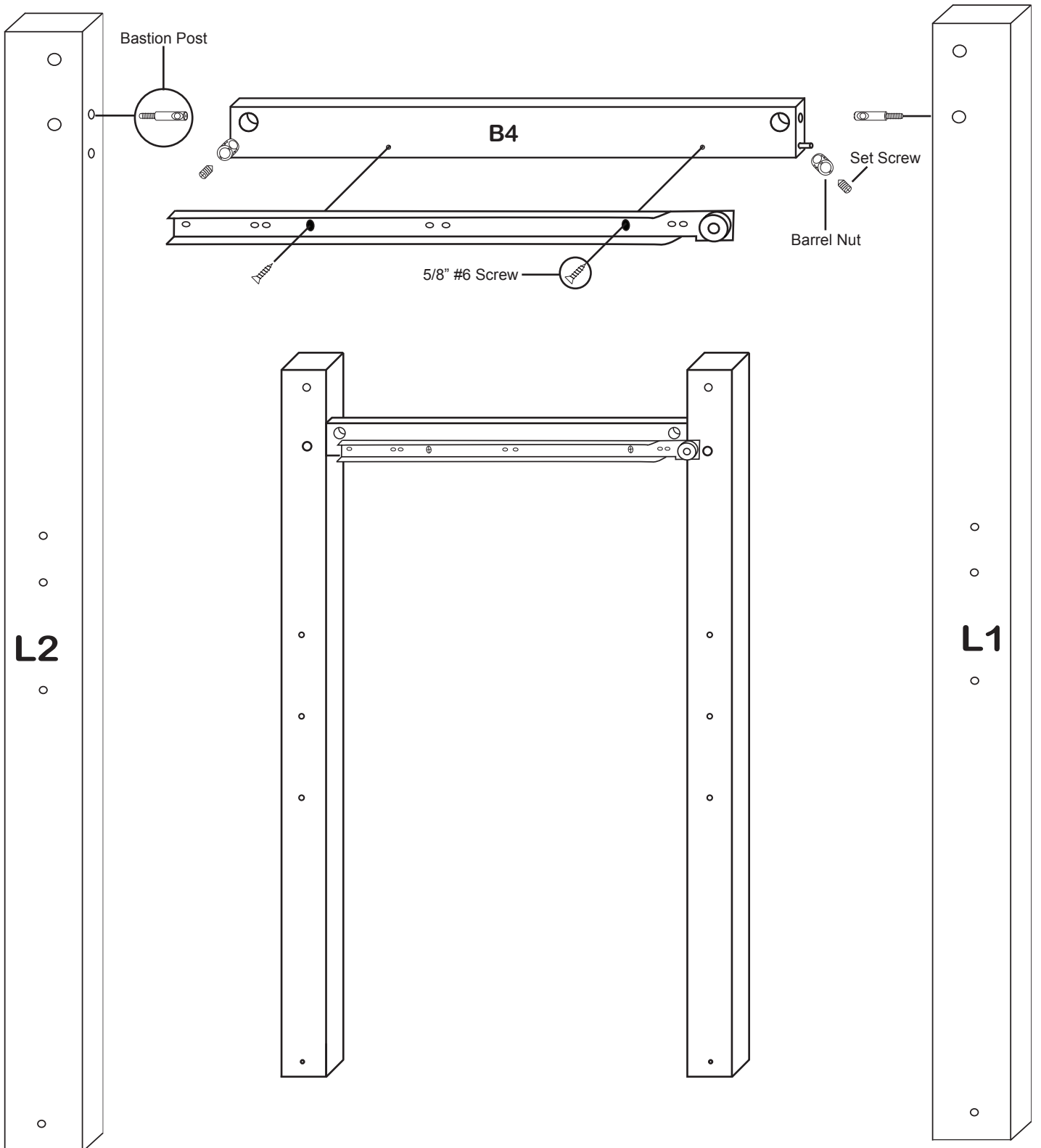

STEP 6

Main Assembly:

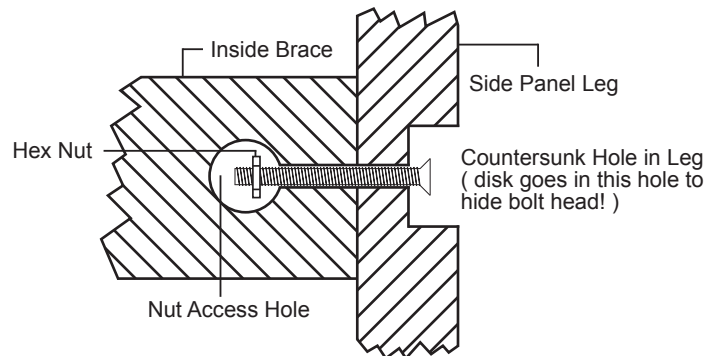
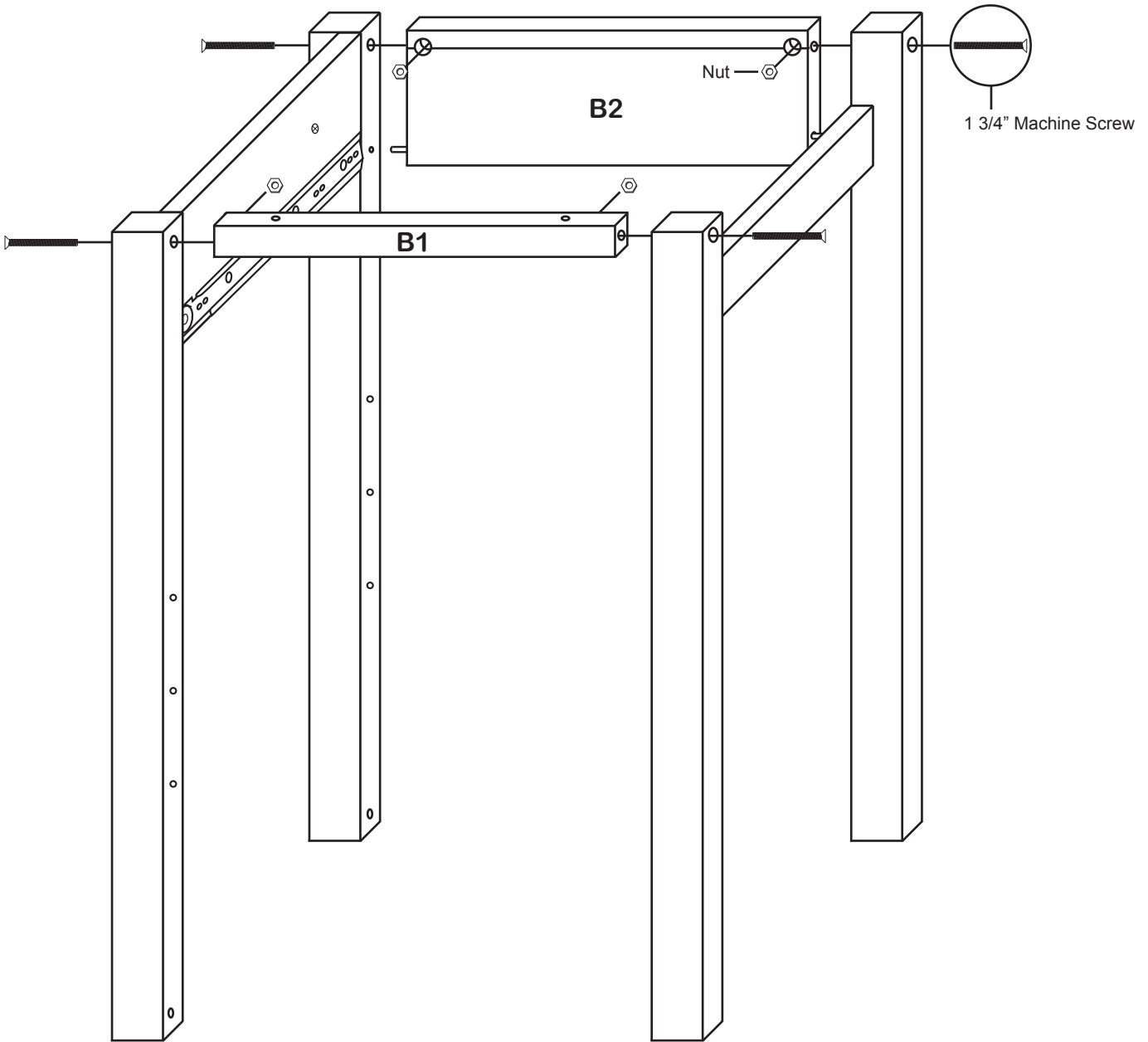

STEP 7

Shelf Assembly:

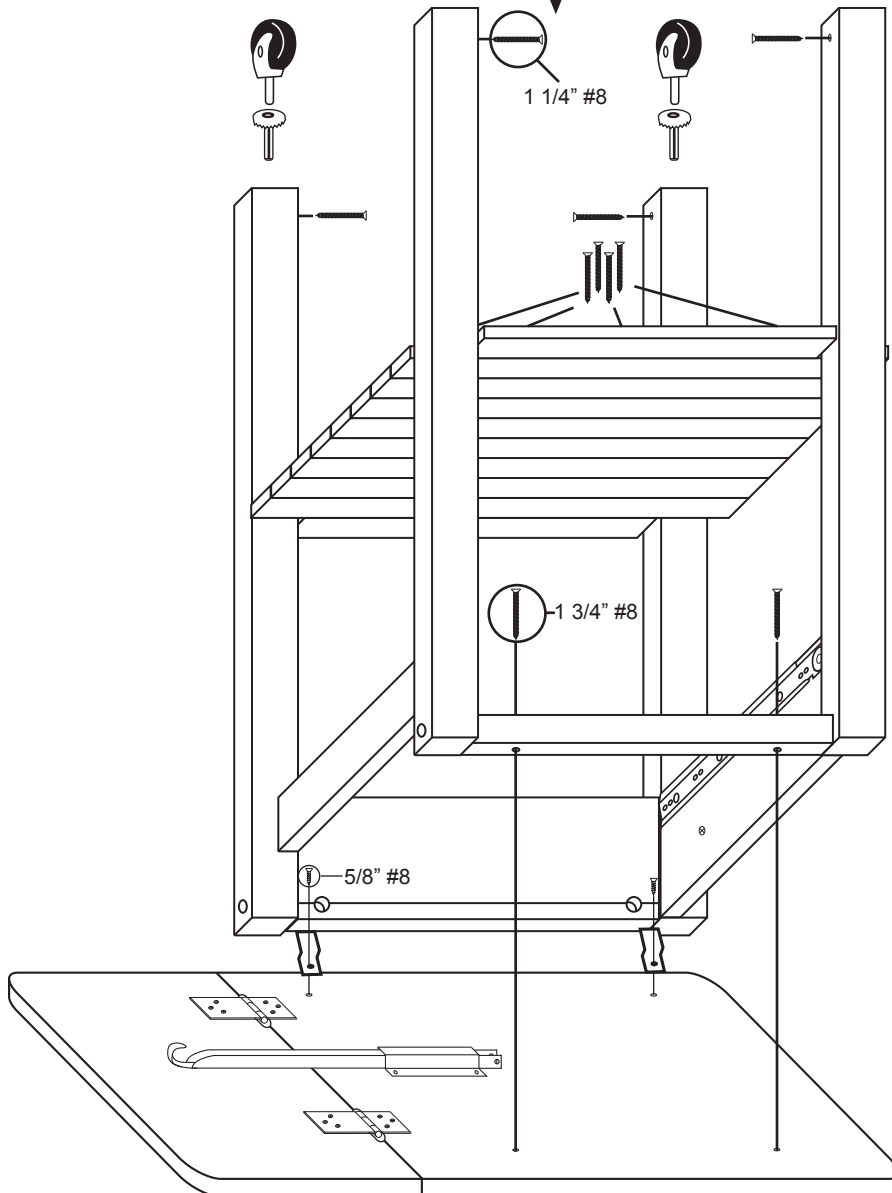
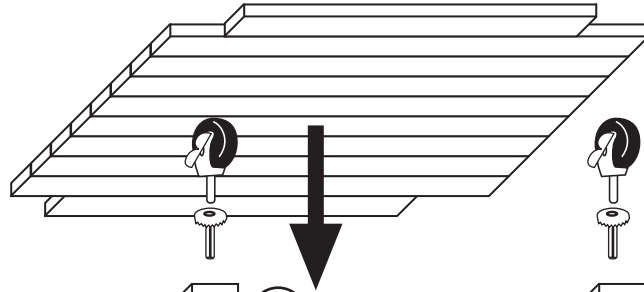
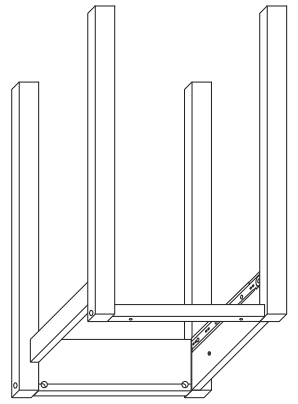
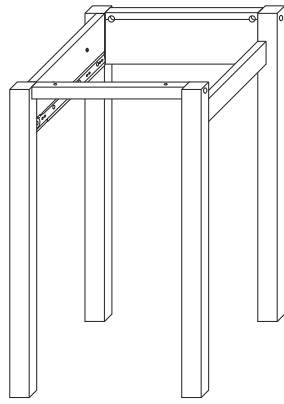

STEP 8

Main Assembly:

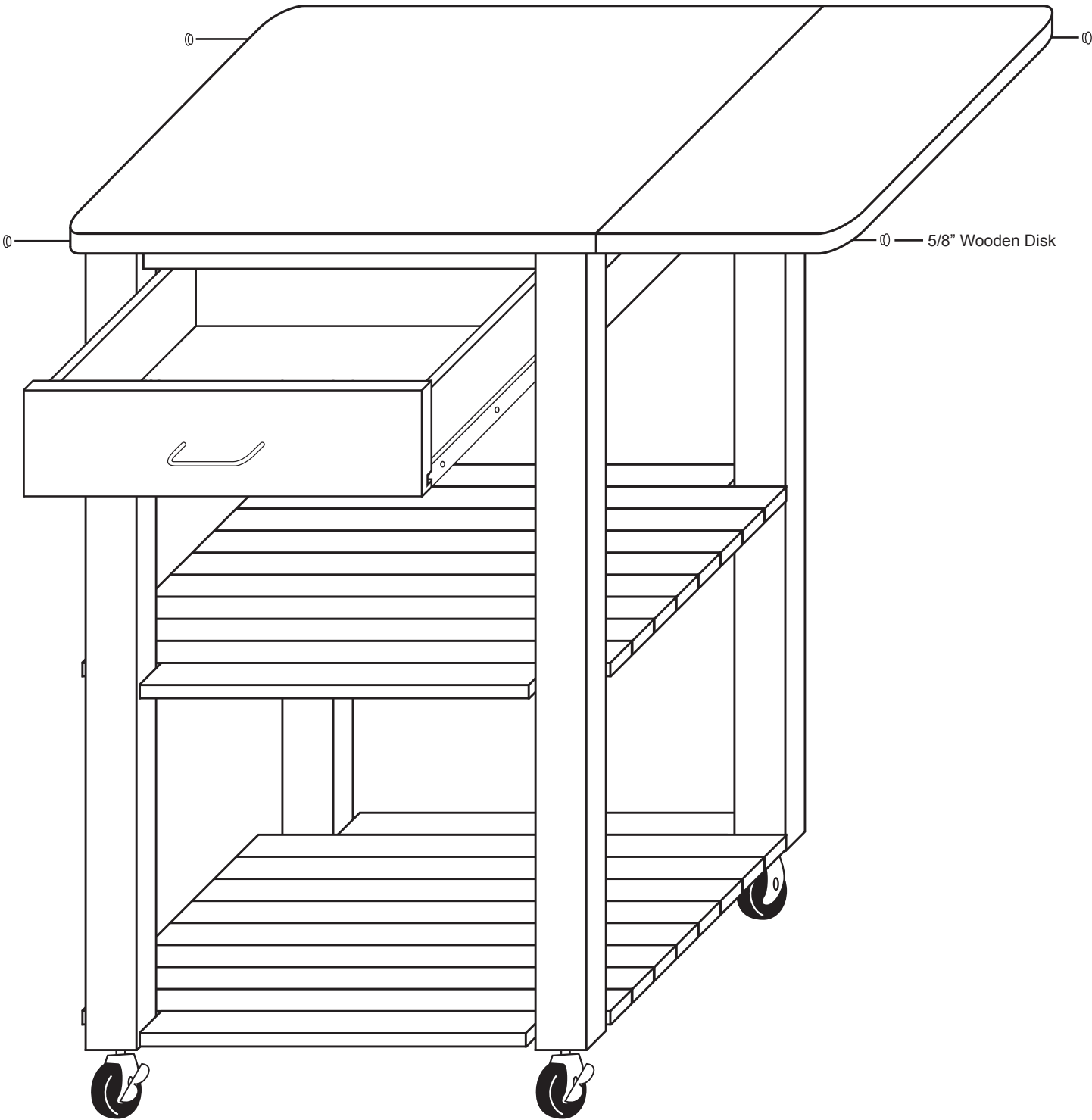



For continued beauty and long life of your Catskill Craftsmen cart, we recommend Catskill Craftsmen's Butcher Block Oil.

If you would like to purchase Butcher Block Oil directly from Catskill Craftsmen's factory, we offer a reduced price. For one eight ounce (8 fl. oz.) bottle, which is sufficient for two applications, simply send \$5.95 along with the completed coupon to the address below.



Catskill Craftsmen, Inc.
15 West End Ave.
Stamford, NY 12167-1296

CATSKILL

CRAFTSMEN, INC.

BUTCHER BLOCK OIL COUPON

Please send me _____ # of bottle(s) of the Catskill Craftsmen Butcher Block Oil at \$5.95. My Check or Money Order is enclosed for a total of \$ _____.

Item Code: 7227

NAME _____

ADDRESS _____

CITY _____

STATE _____ ZIP _____

Please make checks payable to: Catskill Craftsmen Inc.
15 West End Ave. Stamford, NY 12167-1296