

# FEATURES

## PRODUCT SPECIFICATIONS

*Battery.....	58V 4.0Ah Lithium-ion Battery	Height Adjustments.....	1-1/2 in. to 4 in.
Input.....	58V DC only	Wheel Size.....	7 in. front, 10 in. rear
No-load Speed.....	2,800 RPM	Grass Catcher Capacity.....	1.7 Bushel (60L)
Charge time.....	2 hour	Weight.....	57.32 lbs (26 kg)

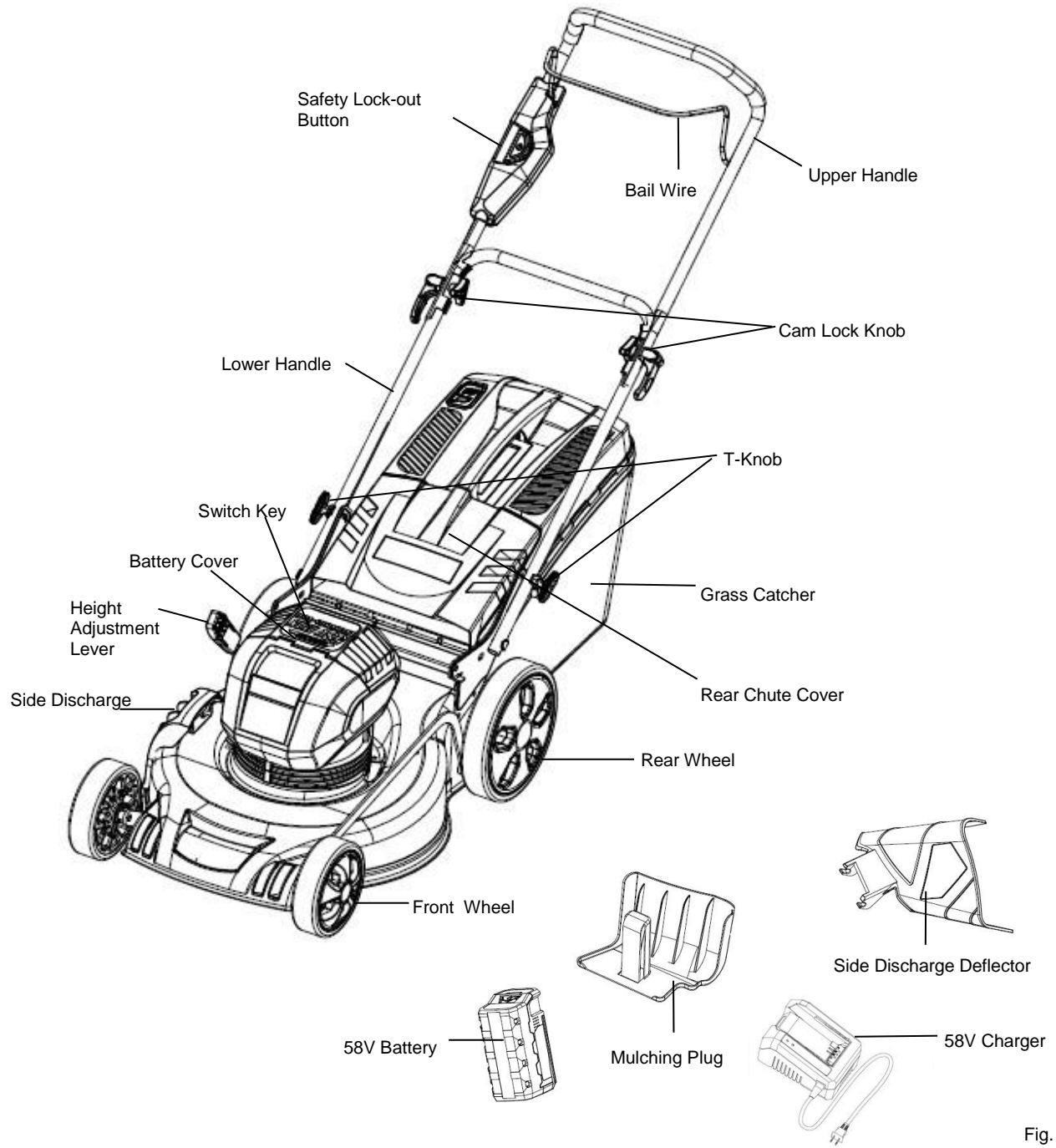

Fig. 1

