

MODEL: 1910

- (2) Side frames RH/LH
- (1) Seat assembly
- (1) Back assembly
- (1) Medallion brace
- (1) Front brace
- (1) Hardware pack

TOOLS NEEDED

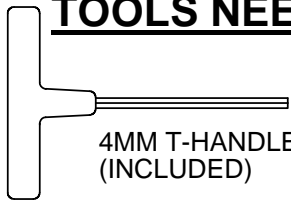

4MM T-HANDLE HEX KEY
(INCLUDED)

STEP 1
Attach braces into pockets on side frames
using (4) 3" screws

Do not tighten screws until last step.

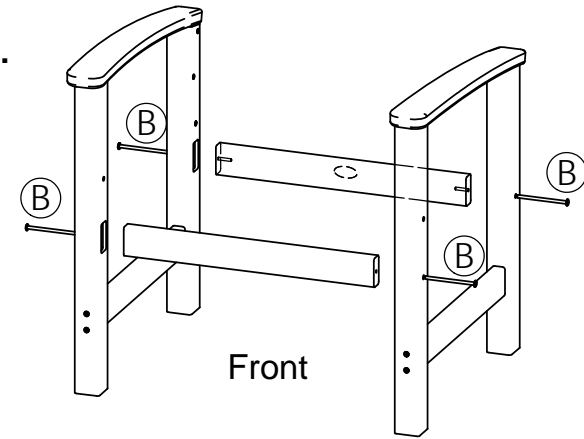

Front

STEP 2
Attach seat assembly to side frames using
(2) 4" screws for front legs and (2) 1-3/4 bolts
for back legs.

STEP 3
Attach back assembly to side frames
using (4) 1-3/4 bolts.

Tighten all screws.

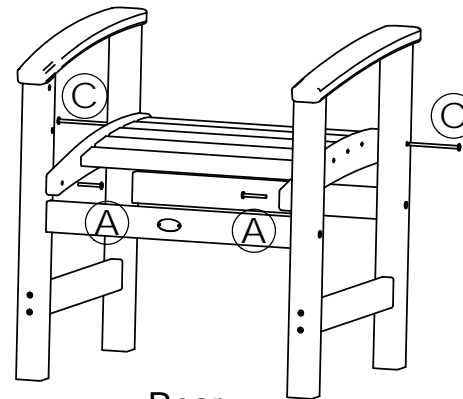

Rear

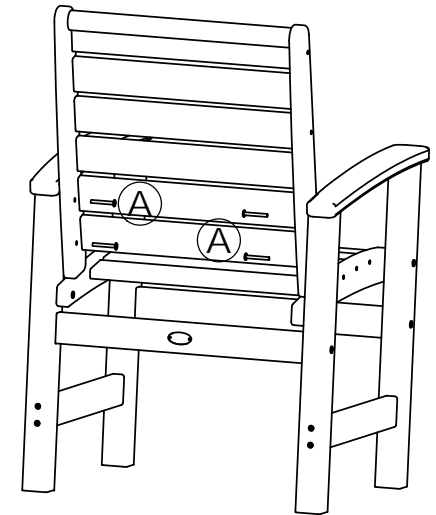

QTY	DESCRIPTION
6	A - 1/4-20 X 1-3/4 WAFER SHCS
4	B - .27 X 3 SOCKET WAFER "A"
2	C - .27 X 4 SOCKET WAFER "A"