

DK43 DETHATCHER KIT INSTALLATION

The Dethatcher Kit is very effective for lifting away the excessive matted layers of thatch that can prevent moisture, oxygen and nutrients from penetrating the soil and can harbor disease and insects. Use in Spring, Summer, and Fall to bring life and color back to your lawn.

1. Flip the ON/OFF switch to the **OFF** position. Remove the cultivating tines or other working tools and the drag stake.
2. Unscrew mount bolts/nuts that connect the wheel bracket to the drag stake mount and set wheel bracket aside. **SEE FIGURE 1**
3. Slide dethatcher shield over the unit's tine shield from the rear of the unit and secure using bolts (176) and nuts (400020). **SEE FIGURE 2**
3. Secure the lower part of the dethatcher shield to the drag stake mount using the lock pin (18039).
4. Install wheel extension plate (4676) using additional bolts (46142) and nuts (4650). Make sure wheel extension is facing the right direction. (The side, with the two holes flush to the edge, connects to the drag stake mount) **SEE FIGURE 1**
 - a. With the mount bolts/nuts attach the wheel extension to the drag stake mount.
 - b. Then with the bracket bolts/nuts (included with the Dethatcher Kit) attach the wheel bracket to the wheel extension.
5. Slide the Left and Right Dethatcher Assemblies onto the tine shaft making sure the Right Assembly is installed on the right side and Left Assembly is installed on the left side as defined from the user's position. **SEE FIGURE 3**
6. Secure dethatcher assemblies using the hairpins (4652). The hairpins go through the inner holes of the tine shaft.

NOTE: The drag stake should not be used when using the dethatcher kit.

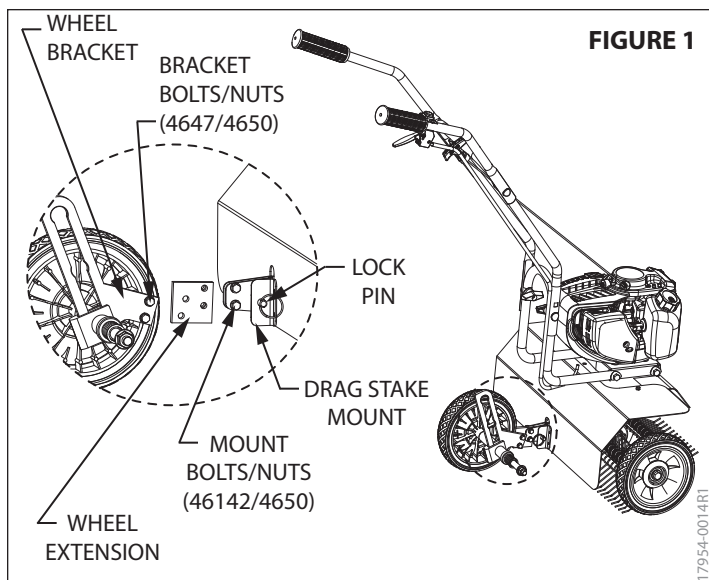

FIGURE 1

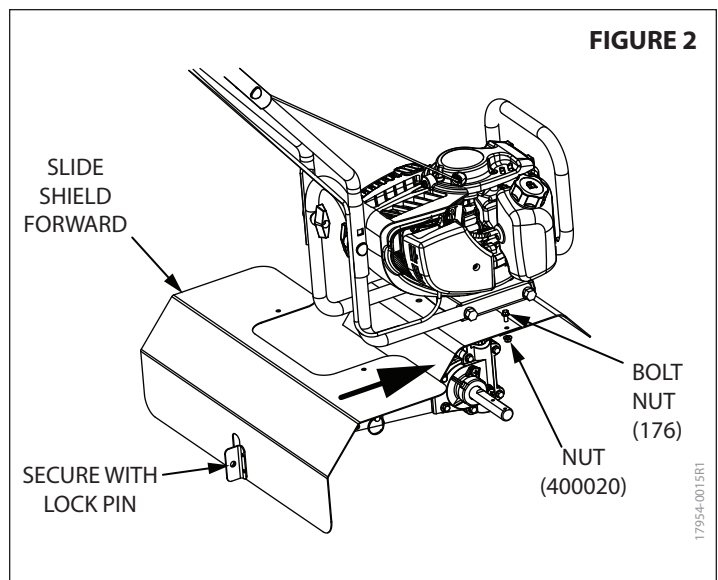

FIGURE 2

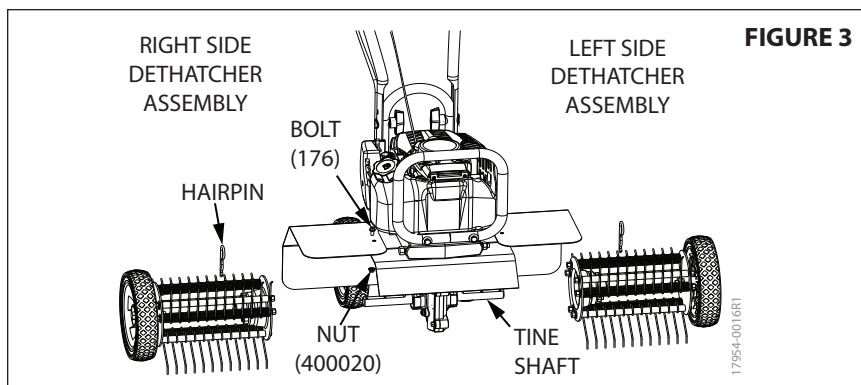

FIGURE 3

Earthquake®
 1160 8th Avenue, PO Box 666
 Cumberland, WI 54829
 800-345-6007 | Fax 715-822-2223
 info@getearthquake.com

All weights, specifications and features are approximate and are subject to change without notice. Due to continuous product improvements, product images may not be exact. Items used for props not included. Some assembly may be required.

P/N: ISDK43
 REV2: 01/09/17
 © 2017 Ardisam, Inc.
 All Rights Reserved