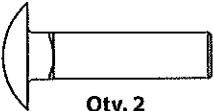
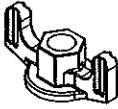
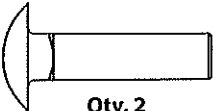
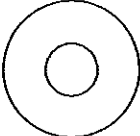
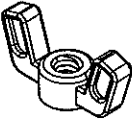

## Contents of Carton

- Lawn Mower (1)
- Lawn Mower Operator's Manual (1)
- Registration Card (1)
- Chute Deflector (1)
- Engine Operator's Manual (1)
- Hardware Pack (1)
- Oil (1)

## Hardware Pack

Group 1	 Qty. 2	 Qty. 2	
Group 2	 Qty. 2	 Qty. 2	 Qty. 2

## Assembly

**NOTE:** This lawn mower is shipped without gasoline or oil in the engine. Fill up the gasoline and oil as instructed in the Engine Operator's Manual BEFORE operating your mower.

### Handle

1. Remove any packing material which may be between upper and lower handles.
  - a. While pushing in on both sides of the lower handle, pull up and back on upper handle as shown in Figure 3-1. Make certain the lower handle is seated securely into the handle mounting brackets. Do not crimp cable while lifting the handle up.
  - b. Tighten wing knobs to secure upper handle to lower handle. Make sure that each carriage bolt is seated properly in the handle.

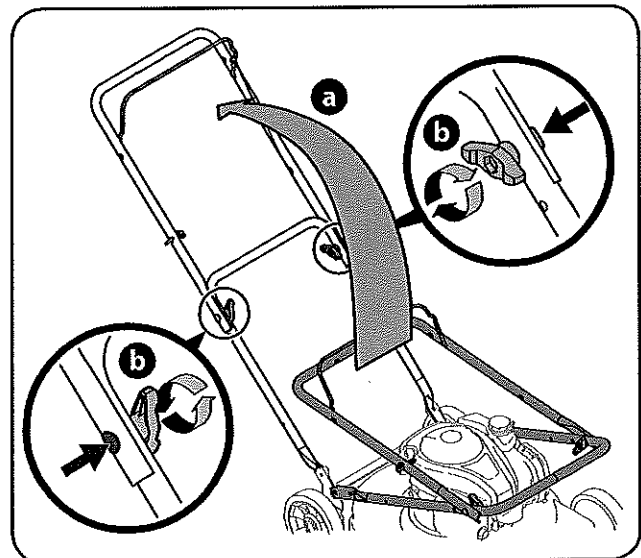
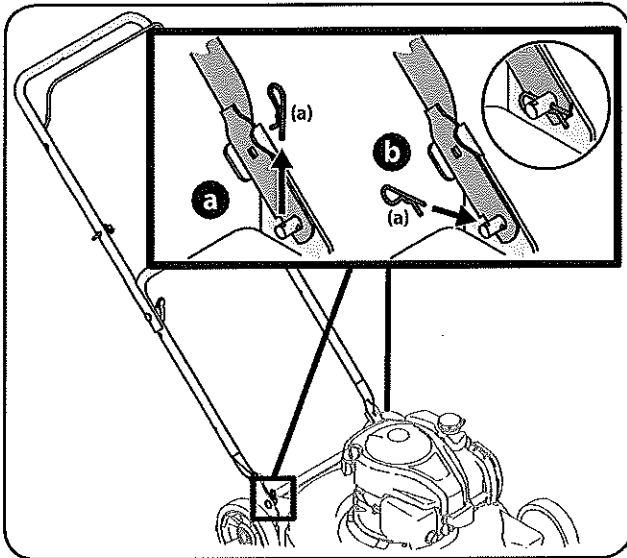

Figure 3-1

2. Locate the hairpin clip on the pivot stud on each side of lower handle.
  - a. Remove hairpin clip (a) from hole at end of stud. See Figure 3-2.



**Figure 3-2**

- b. Insert hairpin clip (a) into the hole on pin closest to the bracket. Repeat on other side.
- c. Insert a carriage screw (a) from Group 1 in the Hardware Pack into the upper hole on the handle mounting bracket. Secure with one plastic wing nut (b) from Group 1. See Figure 3-3. Repeat on other side with remaining hardware from Group 1.

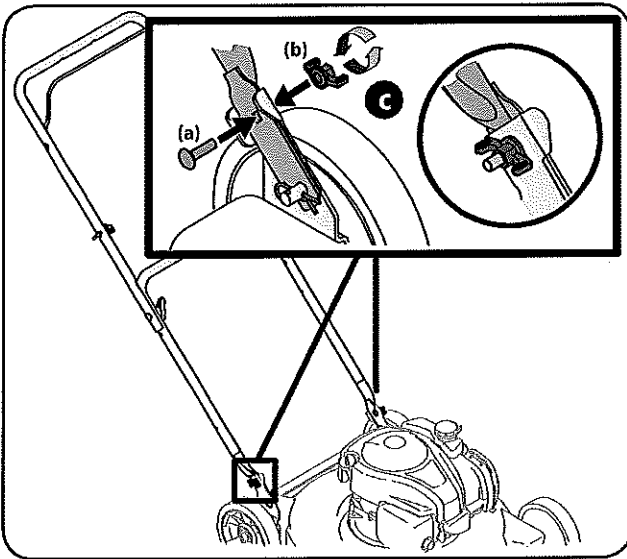

**Figure 3-3**

3. The rope guide is attached to the right side of the upper handle. See Figure 3-4. Loosen the wing nut (a) which secures the rope guide.

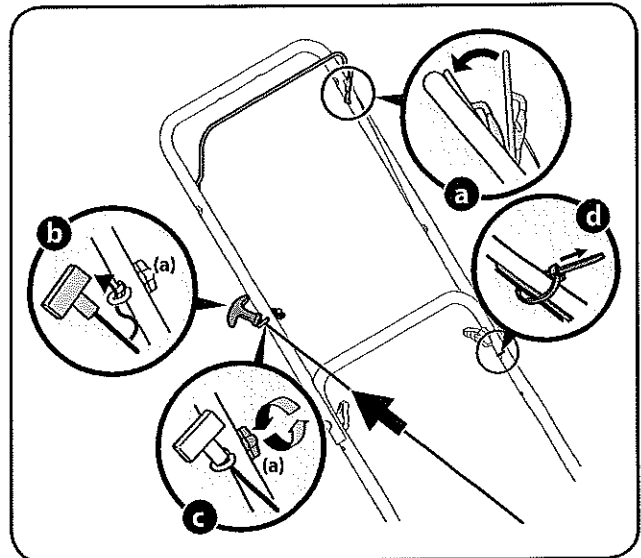

**Figure 3-4**

- a. Hold blade control against upper handle.
- b. Slowly pull starter rope handle out of the engine and slip starter rope into rope guide. See Figure 3-4.
- c. Tighten rope guide wing nut (a).
- d. Insert cable tie into hole provided on the lower handle. Wrap around cable and handle, pull tight, and trim excess.

## Chute Deflector

**NOTE:** Use the hardware in Group 2 to complete the following steps.

1. Align the holes on the chute deflector with the corresponding holes on the deck surface. See Figure 3-5.

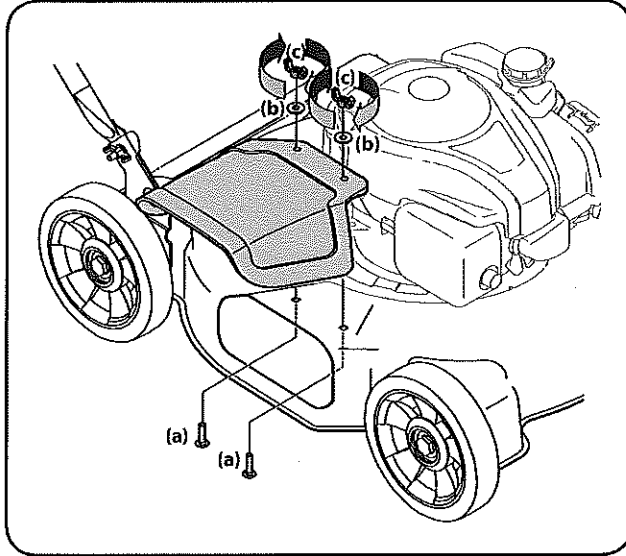

**Figure 3-5**

2. Insert carriage screws (a) up through the underside of the deck and through the chute deflector.
3. Secure each screw (a) with a washer (b) and metal wing nut (c).

## Adjustments

### Cutting Height

1. Remove the shoulder screws (a), washers (b) (front wheels only), and nuts (c) from the wheels. See Figure 3-6.

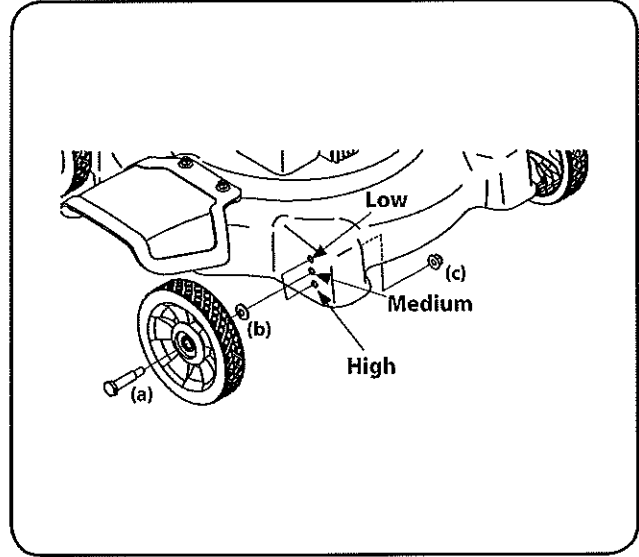

**Figure 3-6**

2. Reattach the wheels with shoulder screws, washers (b) (front wheels only), and nuts (c) at one of the other two holes. Remember to attach ALL wheels at the same relative position to ensure an even cut. For a higher cutting height, use the lower hole on the deck. For a lower cutting height, use the upper hole.

## Set-Up

### Gas and Oil Fill-Up

Refer to the Engine Operator's Manual for additional engine information.

1. Add oil provided before starting unit for the first time out of the box.
2. Service the engine with gasoline as instructed in the Engine Operator's Manual.



**WARNING:** Use extreme care when handling gasoline. Gasoline is extremely flammable and the vapors are explosive. Never fuel the machine indoors or while the engine is hot or running. Extinguish cigarettes, cigars, pipes and any other sources of ignition.