

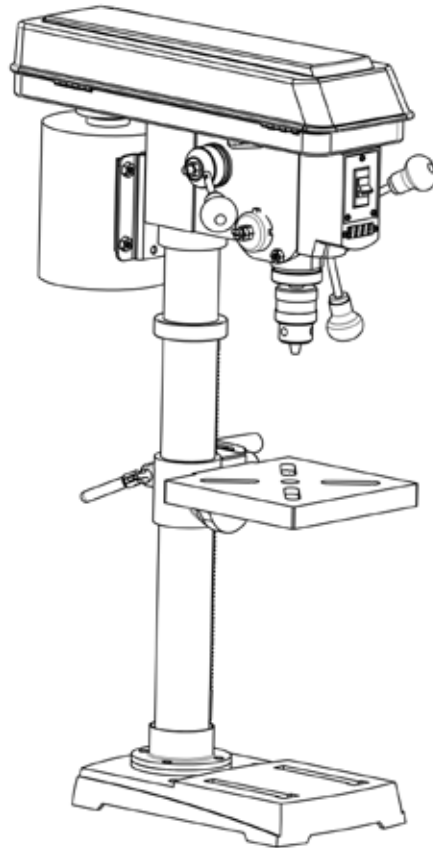

**MODEL 4212**

# 10" VARIABLE SPEED DRILL PRESS

**Instruction Manual**



## ***NEED HELP? CONTACT US!***

Have product questions? Need technical support? Please feel free to contact us:



**1-800-232-1195 (M-F 8AM-5PM CST)**



**TECHSUPPORT@WENPRODUCTS.COM**

**IMPORTANT:** Your new tool has been engineered and manufactured to WEN's highest standards for dependability, ease of operation, and operator safety. When properly cared for, this product will supply you years of rugged, trouble-free performance. Pay close attention to the rules for safe operation, warnings, and cautions. If you use your tool properly and for its intended purpose, you will enjoy years of safe, reliable service.

For replacement parts and the most up-to-date instruction manuals, visit ***WENPRODUCTS.COM***

# CONTENTS

<b>WELCOME</b>	<b>3</b>
Introduction .....	3
Specifications.....	3
<b>SAFETY</b>	<b>4</b>
General Safety Rules .....	4
Drill Press Safety Warnings .....	6
Electrical Information .....	8
<b>BEFORE OPERATING</b>	<b>9</b>
Know Your Drill Press .....	9
Assembly & Adjustments.....	10
<b>OPERATION &amp; MAINTENANCE</b>	<b>18</b>
Operation .....	18
Maintenance.....	21
Troubleshooting Guide.....	22
Exploded View & Parts List.....	24
Warranty Statement .....	27

To purchase replacement parts and accessories for your tool, visit **WENPRODUCTS.COM**

## INTRODUCTION

Thanks for purchasing the WEN Drill Press. We know you are excited to put your tool to work, but first, please take a moment to read through the manual. Safe operation of this tool requires that you read and understand this operator's manual and all the labels affixed to the tool. This manual provides information regarding potential safety concerns, as well as helpful assembly and operating instructions for your tool.

 Indicates danger, warning, or caution. The safety symbols and the explanations with them deserve your careful attention and understanding. Always follow the safety precautions to reduce the risk of fire, electric shock or personal injury. However, please note that these instructions and warnings are not substitutes for proper accident prevention measures.

**NOTE:** The following safety information is not meant to cover all possible conditions and situations that may occur. WEN reserves the right to change this product and specifications at any time without prior notice.

At WEN, we are continuously improving our products. If you find that your tool does not exactly match this manual, please visit [wenproducts.com](http://wenproducts.com) for the most up-to-date manual or contact our customer service at **1-800-232-1195**.

**Keep this manual available to all users during the entire life of the tool and review it frequently to maximize safety for both yourself and others.**

## SPECIFICATIONS

Model Number	4212
Motor	120V, 60 Hz, 5A
Speed	530-3100 RPM (no load)
Chuck Capacity	1/2"
Stroke	2"
Swing	10"
Chuck Taper	JT33
Capacity (Chuck to Base)	15"
Table Bevel	0 to 45° left and right
Weight	57 lbs

# GENERAL SAFETY RULES

**⚠ WARNING!** Read all safety warnings and all instructions. Failure to follow the warnings and instructions may result in electric shock, fire and/or serious injury.

Safety is a combination of common sense, staying alert and knowing how your item works. The term “power tool” in the warnings refers to your mains-operated (corded) power tool or battery-operated (cordless) power tool.

## SAVE THESE SAFETY INSTRUCTIONS.

### WORK AREA SAFETY

- 1. Keep work area clean and well lit.** Cluttered or dark areas invite accidents.
- 2. Do not operate power tools in explosive atmospheres, such as in the presence of flammable liquids, gases or dust.** Power tools create sparks which may ignite the dust or fumes.
- 3. Keep children and bystanders away while operating a power tool.** Distractions can cause you to lose control.

### ELECTRICAL SAFETY

- 1. Power tool plugs must match the outlet. Never modify the plug in any way. Do not use any adapter plugs with earthed (grounded) power tools.** Unmodified plugs and matching outlets will reduce risk of electric shock.
- 2. Avoid body contact with earthed or grounded surfaces such as pipes, radiators, ranges and refrigerators.** There is an increased risk of electric shock if your body is earthed or grounded.
- 3. Do not expose power tools to rain or wet conditions.** Water entering a power tool will increase the risk of electric shock.
- 4. Do not abuse the cord. Never use the cord for carrying, pulling or unplugging the power tool. Keep cord away from heat, oil, sharp edges or moving parts.** Damaged or entangled cords increase the risk of electric shock.
- 5. When operating a power tool outdoors, use an extension cord suitable for outdoor use.** Use of a cord suitable for outdoor use reduces the risk of electric shock.

**6. If operating a power tool in a damp location is unavoidable, use a ground fault circuit interrupter (GFCI) protected supply.** Use of a GFCI reduces the risk of electric shock.

### PERSONAL SAFETY

- 1. Stay alert, watch what you are doing and use common sense when operating a power tool. Do not use a power tool while you are tired or under the influence of drugs, alcohol or medication.** A moment of inattention while operating power tools may result in serious personal injury.
- 2. Use personal protective equipment. Always wear eye protection.** Protective equipment such as a respiratory mask, non-skid safety shoes and hearing protection used for appropriate conditions will reduce the risk of personal injury.
- 3. Prevent unintentional starting. Ensure the switch is in the off-position before connecting to power source and/or battery pack, picking up or carrying the tool.** Carrying power tools with your finger on the switch or energizing power tools that have the switch on invites accidents.
- 4. Remove any adjusting key or wrench before turning the power tool on.** A wrench or a key left attached to a rotating part of the power tool may result in personal injury.
- 5. Do not overreach. Keep proper footing and balance at all times.** This enables better control of the power tool in unexpected situations.
- 6. Dress properly. Do not wear loose clothing or jewelry. Keep your hair and clothing away from moving parts.** Loose clothes, jewelry or long hair can be caught in moving parts.

# GENERAL SAFETY RULES

**⚠ WARNING!** Read all safety warnings and all instructions. Failure to follow the warnings and instructions may result in electric shock, fire and/or serious injury.

Safety is a combination of common sense, staying alert and knowing how your item works. The term “power tool” in the warnings refers to your mains-operated (corded) power tool or battery-operated (cordless) power tool.

## SAVE THESE SAFETY INSTRUCTIONS.

**7. If devices are provided for the connection of dust extraction and collection facilities, ensure these are connected and properly used.** Use of dust collection can reduce dust-related hazards.

### POWER TOOL USE AND CARE

**1. Do not force the power tool. Use the correct power tool for your application.** The correct power tool will do the job better and safer at the rate for which it was designed.

**2. Do not use the power tool if the switch does not turn it on and off.** Any power tool that cannot be controlled with the switch is dangerous and must be repaired.

**3. Disconnect the plug from the power source and/or the battery pack from the power tool before making any adjustments, changing accessories, or storing power tools.** Such preventive safety measures reduce the risk of starting the power tool accidentally.

**4. Store idle power tools out of the reach of children and do not allow persons unfamiliar with the power tool or these instructions to operate the power tool.** Power tools are dangerous in the hands of untrained users.

**5. Maintain power tools. Check for misalignment or binding of moving parts, breakage of parts and any other condition that may affect the power tool's operation. If damaged, have the power tool repaired before use.** Many accidents are caused by poorly maintained power tools.

**6. Keep cutting tools sharp and clean.** Properly maintained cutting tools with sharp cutting edges are less likely to bind and are easier to control.

**7. Use the power tool, accessories and tool bits, etc. in accordance with these instructions, taking into account the working conditions and the work to be performed.** Use of the power tool for operations different from those intended could result in a hazardous situation.

**8. Use clamps to secure your workpiece to a stable surface.** Holding a workpiece by hand or using your body to support it may lead to loss of control.

**9. KEEP GUARDS IN PLACE** and in working order.

### SERVICE

**1. Have your power tool serviced by a qualified repair person using only identical replacement parts.** This will ensure that the safety of the power tool is maintained.

### CALIFORNIA PROPOSITION 65 WARNING

Some dust created by power sanding, sawing, grinding, drilling, and other construction activities may contain chemicals, including lead, known to the State of California to cause cancer, birth defects, or other reproductive harm. Wash hands after handling. Some examples of these chemicals are:

- Lead from lead-based paints.
- Crystalline silica from bricks, cement, and other masonry products.
- Arsenic and chromium from chemically treated lumber.

Your risk from these exposures varies depending on how often you do this type of work. To reduce your exposure to these chemicals, work in a well-ventilated area with approved safety equipment such as dust masks specially designed to filter out microscopic particles.

## ***DRILL PRESS SAFETY WARNINGS***

**⚠ WARNING:** Do not let comfort or familiarity with the product replace strict adherence to product safety rules. Failure to follow the safety instructions may result in serious personal injury.

1. **TOOL PURPOSE.** This drill press is designed to drill through metal wood, plastic, and tiles. Drilling through other materials could result in fire, injury, or damage to the workpiece. Using the machine for any other purpose for which it is not designed may result in serious injuries, machine damage and voiding of the warranty.

2. **MACHINE MOUNTING.** For operation safety, the drill press must be securely mounted onto a flat and stable surface or stand.

3. **PERSONAL SAFETY.**

- Always wear ANSI Z87.1-approved glasses with side shields, hearing protection and a dust mask.
- Do not wear loose clothing or jewelry, as they might get drawn in by the tool. Tie back long hair.
- DO NOT wear gloves while operating this machine.

4. **Electric Cords.** Keep cords away from heat, oil, sharp edges, and moving parts of the tool. Have an electrician replace or repair damaged or worn cords immediately.

5. **TOOL & ACCESSORIES INSPECTION.** Before operation, check the tool and accessories for any damage or missing parts. Do not use the tool if any part is missing or damaged. Make sure all adjustments are correct and all connections are tight. Keep all guards in place.

6. **DRILLING ACCESSORIES.**

- Make sure the drill bit is not damaged before use; only use undamaged drill bits
- Make sure the drill bit is securely locked in the chuck before turning ON.
- Make sure the chuck key is removed from the chuck before turning ON.
- Use clamps or a vise (sold separately to secure a workpiece to the table. This will prevent the workpiece from rotating with the drill bit.

7. Make sure the table lock is tightened before starting the drill press.

8. **WORKPIECE REQUIREMENTS.**

- Only stand workpieces sturdy enough to withstand the force of the drill bit.
- Inspect the workpiece for imperfections, nails, staples, etc. before drilling. Never drill stock that has questionable imperfections or embedded foreign objects.
- Do not drill materials without a flat surface unless a suitable support is used (clamp or vise).

9. **PREVENTING ACCIDENTAL STARTING.** Make sure the power switch is in the OFF position prior to plugging in the machine. Always make sure the power switch is in the OFF position and the machine is unplugged when doing any cleaning, assembly, setup operations, or when not in use.

10. Do not operate this tool until it is completely assembled and installed according to the instructions.

11. Remove scrap pieces and other objects from the table before turning ON the drill press.

## ***DRILL PRESS SAFETY WARNINGS***

### 12. DRILLING THE WORKPIECE.

- Allow spindle to reach full speed before drilling the workpiece.
- Never start the machine with the drill bit pressed against the workpiece.
- Adjust the table or depth stop to avoid drilling into the table.
- Set the drill press to the speed that is appropriate for the material being drilled.

13. Do not touch moving pieces. Keep hands away from the drill bit during operation. If cleaning is necessary, turn off the machine and use a brush to remove sawdust and chips instead of your hands.

14. Never perform layout, assembly or set-up work on the table while the machine is ON.

15. After turning off the drill press, wait until the spindle comes to a complete stop before touching the workpiece. Always turn the drill OFF before removing scrap from the table.

16. Before leaving the machine, always turn OFF and unplug the machine, remove the drill bit, and clean the table. Turn Off and unplug the machine before cleaning, making adjustments or changing drill bits. Accidental start-ups may occur if the tool is plugged in during an accessory change or adjustment.

17. CLEANING. Never use solvents to clean plastic parts. Solvents could dissolve or otherwise damage the material. Use only a soft damp cloth to clean plastic parts.

18. REPLACEMENTS. Should any component of your drill press be missing/damaged or fail in any way, shut OFF the switch and remove the plug from power supply outlet. Replace the missing, damaged, or failed parts using only identical replacement parts before resuming operation.

### **CALIFORNIA PROPOSITION 65 WARNING**

Some dust created by power sanding, sawing, grinding, drilling, and other construction activities may contain chemicals, including lead, known to the State of California to cause cancer, birth defects, or other reproductive harm. Wash hands after handling. Some examples of these chemicals are:

- Lead from lead-based paints.
- Crystalline silica from bricks, cement, and other masonry products.
- Arsenic and chromium from chemically treated lumber.

Your risk from these exposures varies depending on how often you do this type of work. To reduce your exposure to these chemicals, work in a well-ventilated area with approved safety equipment such as dust masks specially designed to filter out microscopic particles.

**These safety instructions can't possibly warn of every scenario that may arise with this tool, so always make sure to stay alert and use common sense during operation.**

# ELECTRICAL INFORMATION

## GROUNDING INSTRUCTIONS

IN THE EVENT OF A MALFUNCTION OR BREAKDOWN, grounding provides the path of least resistance for an electric current and reduces the risk of electric shock. This tool is equipped with an electric cord that has an equipment grounding conductor and a grounding plug. The plug **MUST** be plugged into a matching outlet that is properly installed and grounded in accordance with ALL local codes and ordinances.

**DO NOT MODIFY THE PLUG PROVIDED.** If it will not fit the outlet, have the proper outlet installed by a licensed electrician. Make certain that the outlet in question is properly grounded, if you are unsure have a licensed electrician check the outlet.

**IMPROPER CONNECTION** of the equipment grounding conductor can result in electric shock. The conductor with the green insulation (with or without yellow stripes) is the equipment grounding conductor. If repair or replacement of the electric cord or plug is necessary, **DO NOT** connect the equipment grounding conductor to a live terminal.

**CHECK** with a licensed electrician or service personnel if you do not completely understand the grounding instructions or whether the tool is properly grounded.

**USE ONLY THREE-WIRE EXTENSION CORDS** that have three-pronged plugs and outlets that accept the tool's plug as shown in Fig. 1. Repair or replace a damaged or worn cord immediately.

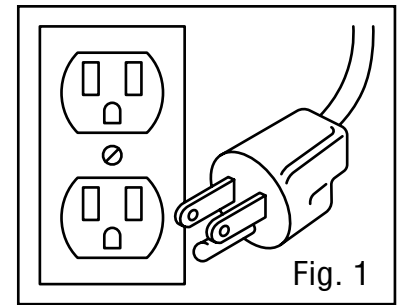

**⚠ WARNING:** This tool is for indoor use only. Do not expose to rain or use in damp locations.

## GUIDELINES AND RECOMMENDATIONS FOR EXTENSION CORDS

When using an extension cord, be sure to use one heavy enough to carry the current your product will draw. An undersized cord will cause a drop in line voltage resulting in loss of power and overheating. The table below shows the correct size to be used according to cord length and ampere rating. When in doubt, use a heavier cord. The smaller the gauge number, the heavier the cord.

AMPERAGE	REQUIRED GAUGE FOR EXTENSION CORDS			
	25 ft.	50 ft.	100 ft.	150 ft.
5A	18 gauge	16 gauge	16 gauge	14 gauge

1. Examine extension cord before use. Make sure your extension cord is properly wired and in good condition. Always replace a damaged extension cord or have it repaired by a qualified person before using it.

2. Do not abuse extension cord. Do not pull on cord to disconnect from receptacle; always disconnect by pulling on plug. Disconnect the extension cord from the receptacle before disconnecting the product from the extension cord. Protect your extension cords from sharp objects, excessive heat and damp/wet areas.

3. Use a separate electrical circuit for your tool. This circuit must not be less than a 12-gauge wire and should be protected with a 15A time-delayed fuse. Before connecting the motor to the power line, make sure the switch is in the OFF position and the electric current is rated the same as the current stamped on the motor nameplate. Running at a lower voltage will damage the motor.



# KNOW YOUR DRILL PRESS

## TOOL PURPOSE

Drill presses are mainly used to drill clean, precise cylindrical holes into workpieces or enlarge existing holes. You may also find other uses for your drill press such as reaming, countersinking, counterboring, tapping, etc. Refer to the diagram below and on page 10 to become familiarized with the parts and controls of your drill press.

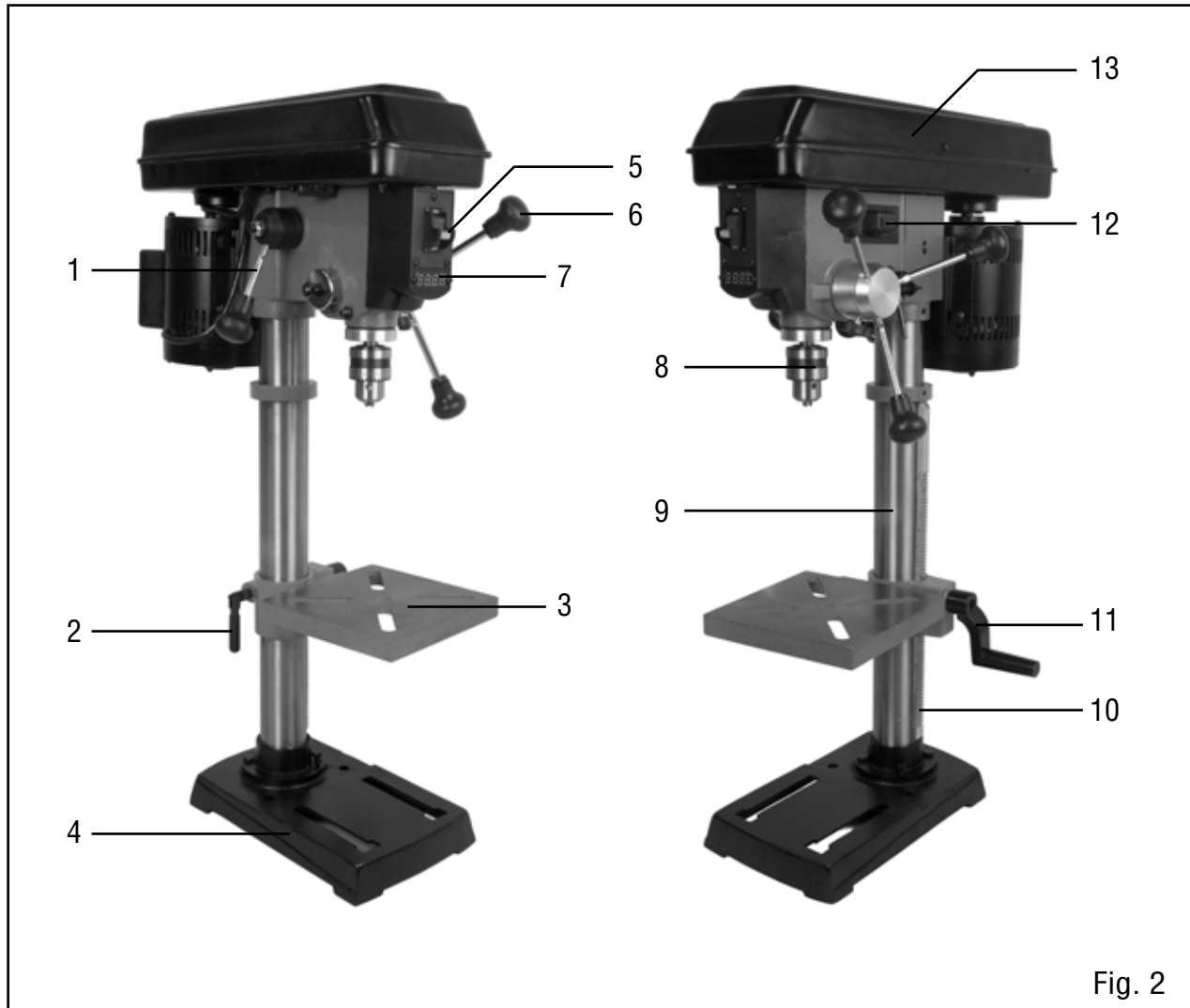

- |                                    |                          |                           |
|------------------------------------|--------------------------|---------------------------|
| 1. Speed Control Handle            | 6. Feed Handle           | 11. Crank Handle          |
| 2. Table Locking Handle            | 7. Digital Speed Readout | 12. Laser ON / OFF Switch |
| 3. Table                           | 8. Chuck                 | 13. Housing Cover Screw   |
| 4. Base                            | 9. Column                |                           |
| 5. ON / OFF Switch with Safety Key | 10. Rack                 |                           |

Various drill bits, vises, clamps and other accessories can be purchased from [wenproducts.com](http://wenproducts.com)

# ASSEMBLY & ADJUSTMENTS

## UNPACKING

With the help of a friend or trustworthy foe, carefully remove the drill press from the packaging. Make sure to take out all contents and accessories. Do not discard the packaging until the drill press is completely assembled.

Before using the drill press, you must assemble the unit using the instructions in this section. Check your packing list against the diagram below. If any part is damaged or missing, please contact our customer service at (800) 232-1195, M-F 8-5 CST or email us at [techsupport@wenproducts.com](mailto:techsupport@wenproducts.com).

## CLEANING THE WORK TABLE SURFACE

Your drill press comes protected with a layer of anti-rust coating on its exposed (non-painted) metal surfaces. Clean the rust-protected surfaces using a soft cloth, moistened with kerosene. Do not use gasoline, or cellulose-based solvents such as paint thinner or lacquer thinner, as these will damage the painted surfaces. After cleaning, apply a light coat of good-quality paste wax to the table and column to prevent rust. Wipe all parts thoroughly with a clean, dry cloth.

## PACKING LIST

Check your packing list against the diagram below. If any part is damaged or missing, please contact our customer service at (800) 232-1195, M-F 8-5 CST or email us at [techsupport@wenproducts.com](mailto:techsupport@wenproducts.com) and **DO NOT** plug the drill press in or turn ON.

Tools needed for assembly (not included):

- Adjustable wrench
- Hammer and block of wood, or rubber mallet, or dead-blow hammer

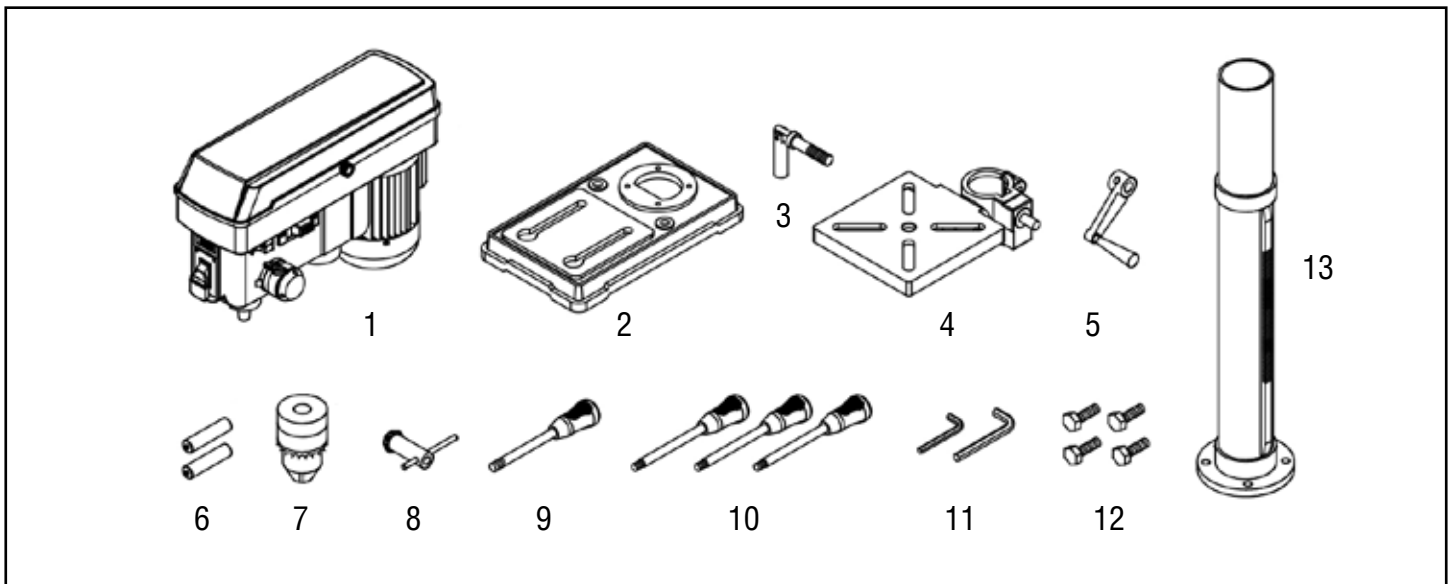

- |                            |                            |                        |
|----------------------------|----------------------------|------------------------|
| 1. Head / Motor Assembly   | 6. AA Batteries (2)        | 11. Hex Wrenches (2)   |
| 2. Base                    | 7. Chuck                   | 12. Hex Head Bolts (4) |
| 3. Table Locking Handle    | 8. Chuck Key               | 13. Column Assembly    |
| 4. Table Assembly          | 9. Speed Adjustment Handle |                        |
| 5. Table Adjustment Handle | 10. Feed Handles (3)       |                        |

## ASSEMBLY & ADJUSTMENTS

**⚠ WARNING:** Do not plug in or turn on the tool until it is fully assembled according on the instructions. Failure to follow the safety instructions may result in serious personal injury.

### ATTACHING COLUMN TO BASE (FIG. 3)

1. Place the column tube (Fig. 3 - 1) on the base (Fig. 3 - 2), aligning the column support holes to the base holes.
2. Install a hex head bolt (Fig. 3 - 3) in each column support hole and tighten bolts using an adjustable wrench (not included).

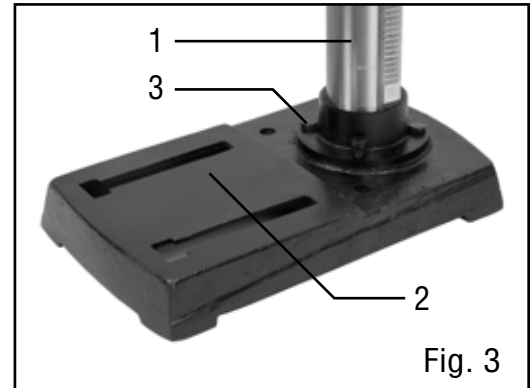

### ATTACHING TABLE TO COLUMN (FIG. 4)

1. Loosen the set screw (Fig. 4 - 4) in the rack collar (Fig. 4 - 5) and remove the collar from the column.

2. Remove the rack (Fig. 4 - 6) from the column (Fig. 4 - 7).

3. Insert the worm shaft (Fig. 4 - 8) into the hole of the table support crank handle (Fig. 4 - 9) from inside the table support. The worm shaft should extend outside the housing about 1" (25 mm).

4. Insert the rack (Fig. 4 - 6) into the geared groove of the table support (Fig. 4 - 9). Make sure the worm shaft (Fig. 4 - 8) on the inside of the table support is engaged with the teeth of the rack. The table support should sit at the center of the rack.

5. Slide the table support and rack assembly (Fig. 5 - 6, 5 - 8, and 5 - 9) down together onto the column. Insert the bottom edge of the rack into the lip (Fig. 5 - 10) of the column support. Hold in this position until step 6 is complete.

6. Place the collar (Fig. 4 - 5) bevel side down over the rack. Tighten the set screw (Fig. 4 - 4) with the 3 mm hex wrench to hold the rack in position.

**NOTE:** Make sure there is enough clearance to allow the table to rotate around the column. To avoid column or collar damage, only tighten the set screw enough to keep collar in place.

7. Insert the table support crank handle (Fig. 6 - 12) into the worm gear shaft on the side of the table support (Fig. 6 - 11). Make sure the set screw (Fig. 6 - 13) is aligned on the flat of the shaft and as close to the table support as possible. Tighten the set screw.

8. Position the table in the same direction as the base, and tighten the column lock handle (Fig. 6 - 14).

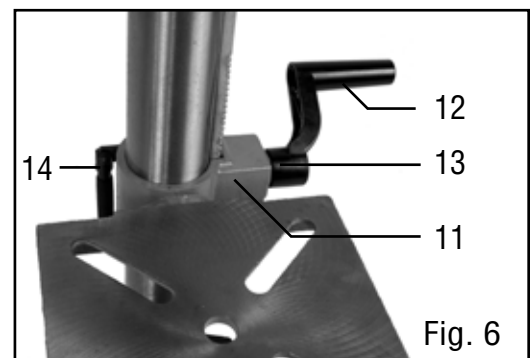
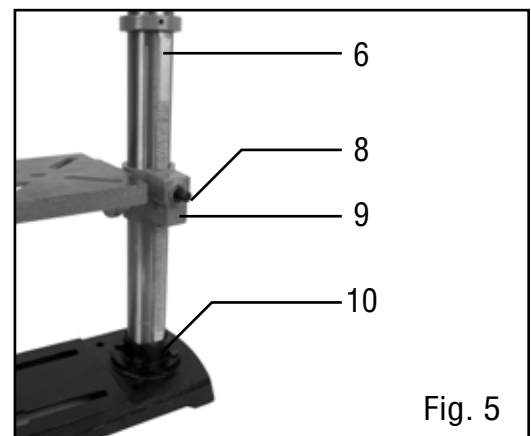
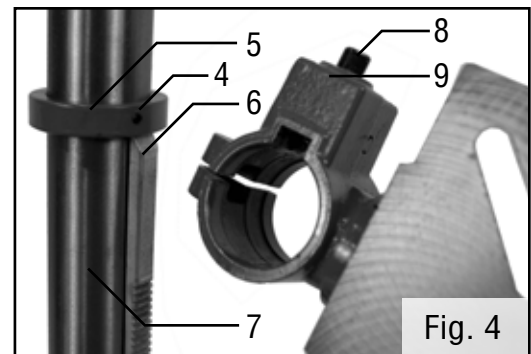

# ASSEMBLY & ADJUSTMENTS

## DRILL PRESS HEAD TO COLUMN (FIG. 7)

**⚠ CAUTION:** The drill press head is heavy. To avoid injury, two people should lift it into position.

1. Carefully lift the drill press head assembly (Fig. 7 - 1) and position it over the column (Fig. 7 - 2).
2. Place the mounting opening on the drill press head over the top of the column. Make sure the drill press head is seated properly on the column.
3. Align the direction of the drill press head with the direction of the base and the table.
4. Tighten the set screws (Fig. 7 - 3) using a hex wrench.

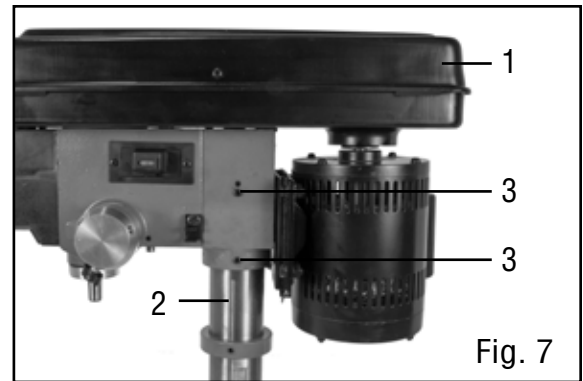

## FEED HANDLES (FIG. 8)

1. Insert the three speed handles (Fig. 8 - 4) into the threaded openings on the feed hub (Fig. 8 - 5).
2. Manually tighten the handles into the openings.

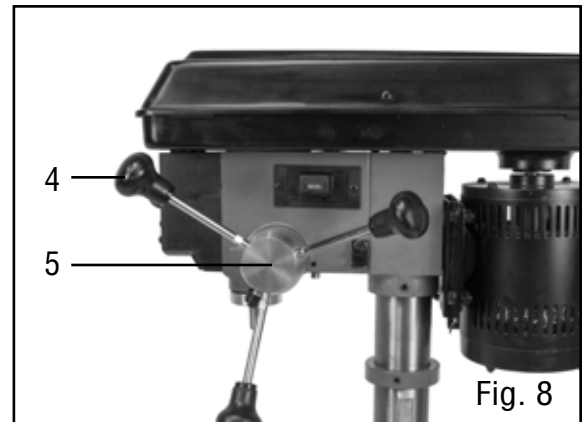

**NOTE:** When using the drill press, one or two of the feed handles may be removed if an unusually-shaped workpiece interferes with the handle rotation.

## SPEED HANDLE (FIG. 9)

1. Insert the speed handle (Fig. 9 - 6) into the threaded opening on the speed hub (Fig. 9 - 7).
2. Manually tighten the handle into the opening.

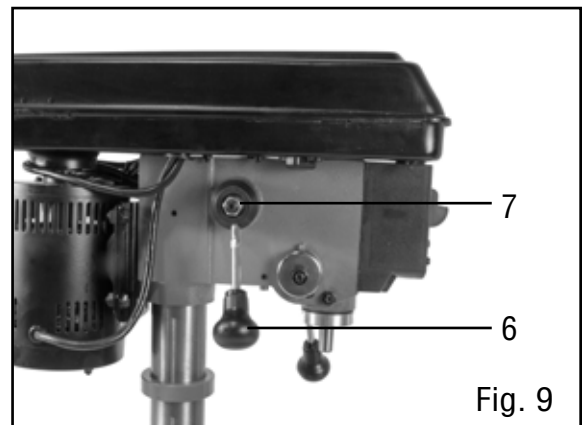

## MOUNTING THE DRILL PRESS (FIG. 10)

The drill press must be securely fastened through the mounting holes (Fig. 10 - 8) to a stand or workbench with heavy-duty fasteners (not included). This will prevent the drill press from tipping over, sliding, or walking during operation.

**IMPORTANT:** If the stand or workbench has a tendency to move during operation, fasten the workbench securely to the floor.

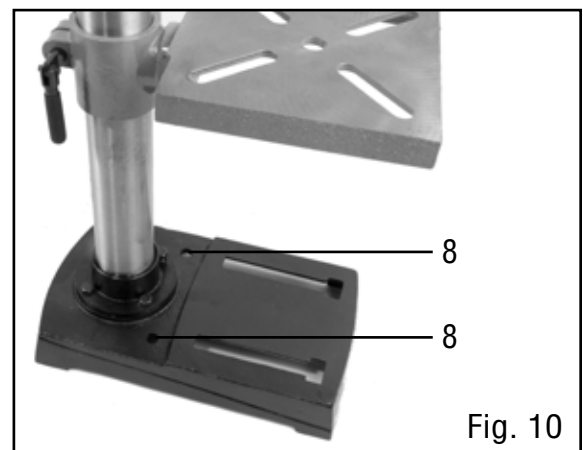

## ASSEMBLY & ADJUSTMENTS

### INSTALL THE CHUCK (FIG. 11)

1. Inspect and clean the taper hole in the chuck and the spindle. Remove all grease, coatings, and particles from the chuck and chuck arbor surfaces with a clean cloth.
2. Open the chuck jaws by manually turning the chuck barrel clockwise. Make sure the jaws are completely recessed inside the chuck.
3. Seat the chuck on the chuck arbor by placing a block of wood (not included) under the chuck and tapping the wood with a hammer (not included). Alternatively, tap the chuck with a rubber mallet (not included). Pull firmly down on the chuck to ensure it is properly seated on the spindle. If it comes loose, clean the tapers and repeat steps 1-3 until the chuck is properly seated.

**CAUTION:** To avoid damaging the chuck, make sure the jaws are completely recessed into the chuck. Do not use a metal hammer to drive the chuck into the spindle.

### REMOVE THE CHUCK

1. Turn the feed handles to lower the chuck to the lowest position.

2. Place a ball joint separator above the chuck and tap it lightly with a hammer to cause the chuck to drop from the spindle. Alternately, you may use a set of #6 Jacobs wedges (sold separately).

**NOTE:** Be prepared to catch chuck as it falls, or place a cloth on the table to avoid damage to the table or chuck.

### RAISE AND LOWER THE TABLE (FIG. 12)

1. Loosen the support lock handle (Fig. 12 - 1) and turn the crank handle (Fig. 12 - 2) until the table is at the desired height.

2. Tighten the support lock handle before drilling.

### ROTATE THE TABLE (FIG. 12)

1. Loosen the support lock handle (Fig. 12 - 1) and turn the table around the column to the desired position.

**NOTE:** The rack should rotate around the column with the table support bracket. If the rack binds and does not rotate, slightly loosen the set screw in the rack collar.

2. Tighten the support lock before drilling.

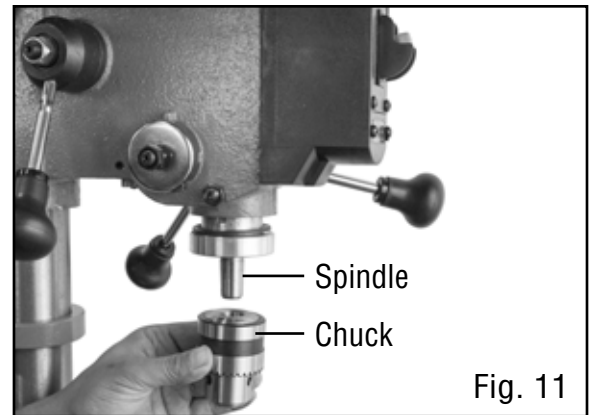

Fig. 11

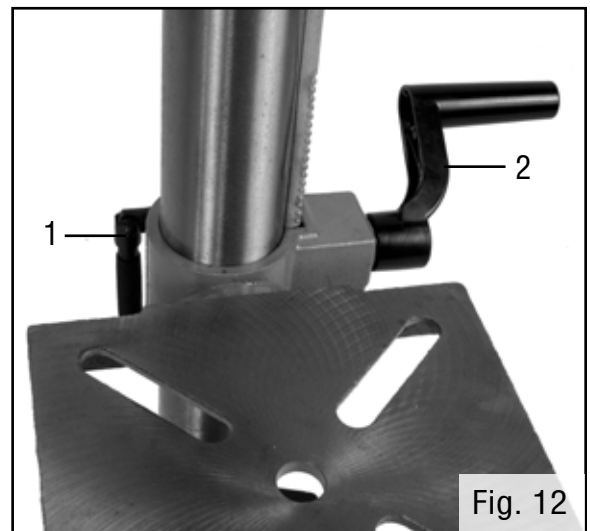

Fig. 12

## ASSEMBLY & ADJUSTMENTS

### TILT THE TABLE (FIG. 13)

1. Loosen the bevel lock bolt (under table) with a suitable socket or wrench (not included).
2. Tilt the table to the desired angle, using the bevel scale (1) as a basic guide.
3. Re-tighten the bevel lock bolt.
4. To return the table to its original horizontal position, loosen the bevel lock bolt.
5. Realign the table to the 0° setting on the bevel scale.
6. Tighten the bevel lock bolt with the wrench.

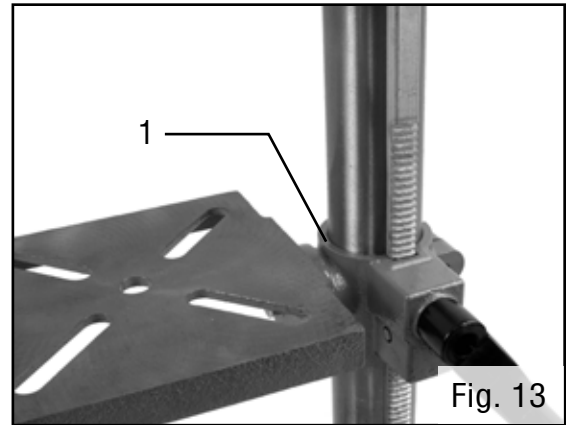

Fig. 13

**⚠ WARNING:** Make sure the chuck key is removed from the chuck before starting any drilling operation.

### INSTALLING A DRILL BIT

1. Place the chuck key into the side keyhole of the chuck, meshing the key with the gear teeth.
2. Turn the chuck key counterclockwise to open the chuck jaws on the bit shank.
3. Insert a drill bit into the chuck far enough to obtain the maximum grip of the chuck jaws.
4. Center the drill bit in the chuck jaws before the final tightening of the chuck.
5. Tighten the chuck jaws using the chuck key to ensure that the drill bit will not slip while drilling. Tighten all three holes on the chuck to ensure maximum grip on the bit.
6. Remove the chuck key.

## ASSEMBLY & ADJUSTMENTS

### SQUARING THE TABLE TO THE DRILL BIT (FIG. 14)

1. Insert a 3" drill bit (Fig. 14-1) into the chuck (Fig. 14-2) and tighten.
2. Raise and lock the table (Fig. 14 - 3) about 1" from the end of the drill bit.
3. Place a combination square (Fig. 14 - 4) on the table as shown. The drill bit should be parallel to the straight edge of the square.
4. If an adjustment is needed, loosen the bevel lock (Fig. 14 - 5) with a wrench.
5. Square the table to the bit by tilting the table.
6. Tighten the bevel lock bolt (Fig. 14 - 5) when square.

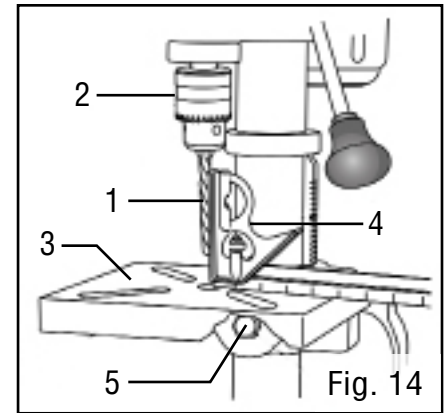

**⚠ WARNING:** Do not stare directly at the laser beam. Observe all safety rules.

- Never aim the beam at a person or an object other than the workpiece.
- Always make sure the laser beam is aimed at a workpiece that does not have reflective surfaces, as the laser beam could reflect into your eyes or the eyes of others.

### ADJUSTING THE LASER (FIG. 15)

1. Place a workpiece on the table.
2. Turn the laser switch to the ON position.
3. Lower the drill bit to meet the workpiece. The two laser lines should cross where the drill meets the workpiece.
4. If the laser needs to be adjusted:
  - a) Using a 3 mm hex key, turn the laser adjustment screws (Fig. 15 - 1) counterclockwise.
  - b) Rotate the laser light housing (Fig. 15 - 2) until the two laser lines intersect where the drill meets the workpiece. DO NOT stare directly at the laser lines.
5. Re-tighten the adjustment set screws (Fig. 15 - 1).

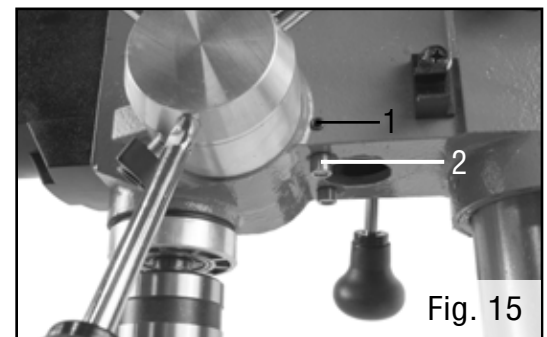

## ASSEMBLY & ADJUSTMENTS

### SPINDLE RETURN SPRING (FIG. 16A)

The spindle is equipped with an auto-return mechanism. The main components are a spring and a notched housing. The spring was properly adjusted at the factory and should not be readjusted unless absolutely necessary.

1. Unplug the drill press.
2. Place a screwdriver into the loop (Fig. 16A - 1) to hold the spring in place.
3. Loosen the two housing nuts (Fig. 16A - 3) approximately 1/4" (6 mm). Do not remove the nuts from the threaded shaft. Do not allow the spring or spring housing to slip out of control.
4. While firmly holding the spring housing (Fig. 16A - 4), carefully pull the spring housing out until it clears the raised notch (Fig. 16A - 2).
5. Turn the housing so that the next notch is engaged with the raised notch (Fig. 16A - 2).
  - To increase the spindle return tension, turn the spring housing counter-clockwise.
  - To decrease the tension, turn the spring housing clockwise.
6. Tighten the two housing nuts. Do not overtighten the two nuts. If the nuts are tightened too much, the movement of the spindle and feed handles will become sluggish.

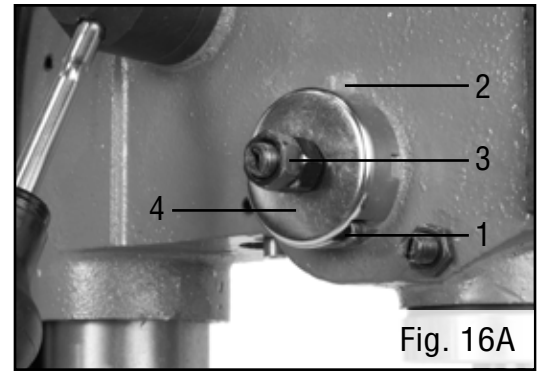

### ANGULAR "PLAY" OF THE SPINDLE (FIG. 16B)

Move the spindle to the lowest downward position and hold in place. Try to make the spindle revolve around its axis while also moving it with a side motion. If there is too much "play", proceed as follows:

1. Loosen the lock nut (Fig. 16B - 5).
2. Without obstructing the upward and downward motion of the spindle, turn the screw (Fig. 16B - 6) clockwise to eliminate the "play." **NOTE:** A little bit of "play" is normal.
3. Tighten the lock nut (Fig. 16B - 5).

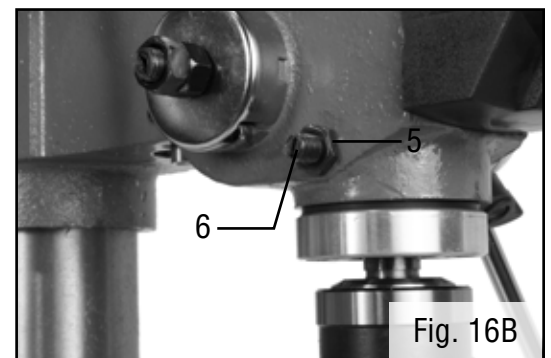



## ASSEMBLY & ADJUSTMENTS

### DRILL PRESS ON/OFF SWITCH (FIG. 17)

1. To turn the drill press ON, insert the yellow safety key (Fig. 17-1) into the switch housing (Fig. 17 - 2). As a safety feature, the switch cannot be turned ON without the safety key.
2. Turn the switch to the ON position.
3. To turn the drill press OFF, flip the switch downward.
4. To lock the switch in the OFF position, remove the safety key (Fig. 17 - 1) from the switch. Store the safety key in a safe place.

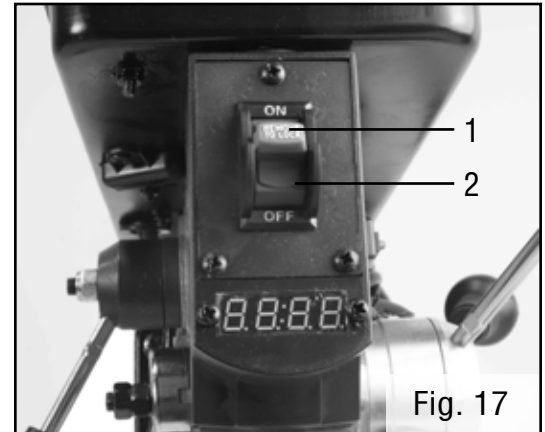

### CHANGING THE BELT

**⚠ WARNING:** Disconnect the drill press from the power source before replacing the belt.

Belt tension and drill press speed is controlled by automatic adjustments made to the diameter of the front spindle when the speed handle is moved.

**NOTE:** See page 19 for information on the variable speed function of this drill press.

1. Plug in the drill press and turn it ON. Adjust the speed to the highest setting, then turn the drill press OFF and unplug it.
2. Open the belt cover (remove the Phillips-head screw from the right side, then open the lid).
3. Press down on the bottom side of the motor pulley. This will loosen the belt tension. Work the belt off the pulleys.
4. Place the new belt on the motor pulley, then press down on the bottom side of the pulley as before and get the belt as close to the motor shaft as possible. Make sure the bottom side of the pulley is pushed fully downward.
5. Work the belt around the spindle pulley. The belt will not be taut, but will self-seat later.
6. Close and secure the belt cover.
7. Plug in and turn ON the drill press. The belt will self-seat and achieve proper tension on its own.

**⚠ WARNING:** Do not change the drive speed when the drill press is turned off.

## OPERATION

### LASER LINE ON/OFF SWITCHES (FIG. 18)

The laser switch (Fig. 18 - 1) is located on the left hand side of the drill press.

1. Pull the tab located below the laser switch and lift up the laser switch cover (Fig. 18 - 2).
2. Install two AA batteries into the battery slots and close the switch cover.

### POSITION THE TABLE AND WORKPIECE

Always place a piece of backup material (wood, plywood, etc.) on the table underneath the workpiece. This will prevent splintering on the underside of the workpiece as the drill bit breaks through. To keep the material from spinning out of control, it must contact the left side of the column, or be clamped (not included) to the table.

**NOTE:** For small workpieces that cannot be clamped to the table, use a drill press vise (not included). The vise must be clamped or bolted to the table to avoid injury.

### DRILLING GUIDELINES - DRILLING A HOLE

**⚠ WARNING:** To prevent the workpiece and the backup material from slipping from your hand while drilling, position the workpiece and backup material to the left side of the column. If the workpiece and the backup material are not long enough to reach the column, clamp the workpiece and back material to the table. Failure to do this could result in personal injury. (Fig. 19)

1. Mark where you want to drill the workpiece by using a center punch or a sharp nail. Turn ON the laser to mark your drilling point.
2. Before turning the drill press ON, turn the feed handles to bring the drill bit down. Line the drill bit tip up with the mark. Clamp the workpiece in place.
3. Turn ON the drill press and pull down on the feed handles with the appropriate force needed to allow the drill bit to drill the material.

**NOTE:** Feeding too slowly might cause the drill bit to turn in the chuck. Feeding too rapidly might stop the motor, cause the belt to slip, force the workpiece loose, or break the drill bit. Practice with scrap material to get the feel of the machine before attempting to do any drilling operation.

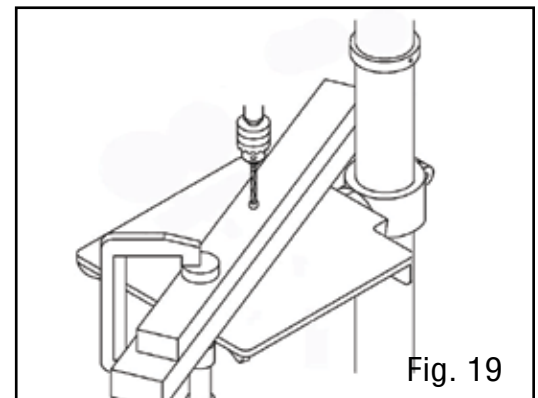
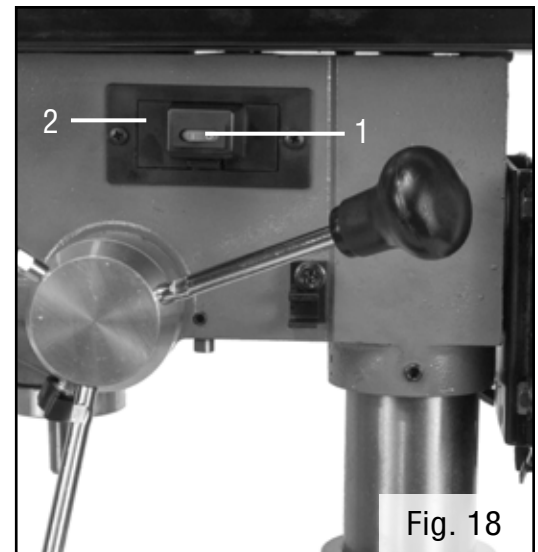

## OPERATION

### ADJUST THE DRILLING DEPTH (FIG. 19)

1. Loosen the depth scale knob and turn the depth scale ring to the desired depth.
2. Lock the scale ring in place by tightening the depth knob. This will stop the bit once it reaches a certain depth.

### DRILLING SPEEDS

**NOTE:** View Drill Bit Size Recommendations on page 20 for general guidelines.

There are a few important factors to keep in mind when determining the best drilling speed:

- Material type
- Hole size
- Drill bit or cutter type
- Quality desired

Smaller drill bits require greater speed than larger drill bits. Softer materials require greater speed than harder materials. See page 19 for recommended speeds for particular materials.

### DRILLING METAL

- Use metal-piercing twist drill bits.
- It is always necessary to lubricate the tip of the drill with oil to prevent overheating of the drill bit.
- All metal workpieces should be clamped down securely. Any tilting, twisting, or shifting causes a rough drill hole, and increases the potential of drill bit breakage.
- Never hold a metal workpiece with your bare hands. The cutting edge of the drill bit may seize the workpiece and throw it, causing serious injury.
- If the metal is flat, clamp a piece of wood under it to prevent turning. If it cannot be laid flat on the table, then it should be blocked and clamped.

### DRILLING WOOD

- Brad point bits are preferred. Metal piercing twist bits may be used on wood.
- Do not use auger bits. Auger bits turn so rapidly that they can lift the workpiece off of the table and whirl it around.
- Always protect the drill bit by positioning the table so that the drill bit will enter the center hole when drilling through the workpiece.
- To prevent splintering, feed the drill bit slowly right as the bit is about to cut through to the backside of the workpiece.
- To reduce splintering and protect the point of the bit, use scrap wood as a backing or a base block under the workpiece.



# OPERATION

## FEEDING THE DRILL BIT

- Pull down on the feed handles with only enough force to allow the drill bit to cut.
- Feeding too rapidly might stall motor, cause the belt to slip, damage the workpiece, or break the drill bit.
- Feeding too slowly will cause the drill bit to heat up and burn the workpiece.

## MECHANICAL VARIABLE SPEED (FIG. 21)

This is a mechanical variable speed drill press. To increase or decrease the speed when operating, raise or lower the speed handle (Fig. 21 - 1).

Use the following table to determine the recommended speed for the drill size you are using and the type of material you are to drill. While drilling, check the speed on the digital speed readout (Fig. 21 - 2) located at the front of the drill press.

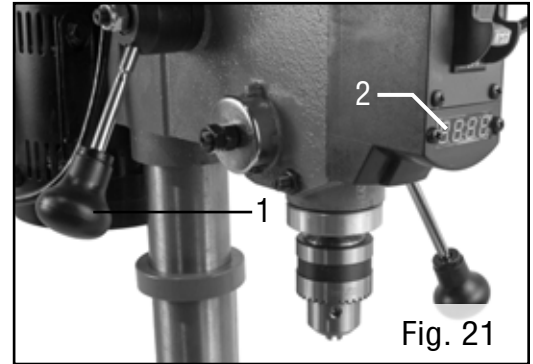

**WARNING:** Do not change speeds using the variable speed handle without turning on the machine.

### DRILL BIT SIZE RECOMMENDATIONS

RPM	Wood		Aluminum, Zinc, Brass		Iron, Steel	
2000 to 3100	3/8 in.	9.5 mm	7/32 in.	5.6 mm	3/32 in.	2.4 mm
1400 to 2000	5/8 in.	16 mm	11/32 in.	8.75 mm	5/32 in.	4 mm
1000 to 1400	7/8 in.	22 mm	15/32 in.	12 mm	1/4 in.	6.4 mm
800 to 1000	1-1/4 in.	31.75 mm	11/16 in.	17.5 mm	3/8 in.	9.5 mm
530 to 800	1-5/8 in.	41.4 mm	3/4 in.	19 mm	5/8 in.	16 mm

# MAINTENANCE

**⚠ WARNING:** To avoid accidents, turn OFF and unplug the tool from the electrical outlet before cleaning, adjusting, or performing any maintenance or lubrication work.

**⚠ WARNING:** Any attempt to repair or replace electrical parts on this tool may be hazardous. Servicing of the tool must be performed by a qualified technician. When servicing, use only identical WEN replacement parts. Use of other parts may be hazardous or induce product failure.

## ROUTINE INSPECTION

Before each use, inspect the general condition of the tool. If any of these following conditions exist, do not use until parts are replaced.

### CHECK FOR:

- Loose hardware or improper mounting,
- Misalignment
- Damaged cord/electrical wiring,
- Cracked or broken parts, and
- Any other condition that may affect its safe operation

**CAUTION:** Most plastics are susceptible to damage from various types of commercial solvents. Do not use any solvents or cleaning products that could damage the plastic parts. Some of these include but are not limited to: gasoline, carbon tetrachloride, chlorinated cleaning solvents, and household detergents that contain ammonia.

## CLEANING & STORAGE

1. After every operation, use a vacuum to remove sawdust or metal shavings from the tool surfaces, motor housing and work area. Keep the ventilation openings free from dust and debris to prevent the motor from overheating.
2. Wipe the tool surfaces clean with a soft cloth or brush. Make sure water does not get into the tool.
3. Apply a light coat of paste wax to the column and table to help keep these surfaces clean and rust free.
4. Store the tool in a clean and dry place away from the reach of children.

## LUBRICATION

The ball bearings in the spindle and the V-belt pulley assembly are greased and permanently sealed, and require no lubrication. Pull the spindle down and oil the quill moderately every three months. Periodically lubricate the motor pulley and motor shaft to avoid excessive vibration or speed adjustment failure.

Lubricate the table bracket and locking knobs if they become difficult to use.

## PRODUCT DISPOSAL

Used power tools should not be disposed of together with household waste. This product contains electronic components that should be recycled. Please take this product to your local recycling facility for responsible disposal and to minimize its environmental impact.

## **TROUBLESHOOTING GUIDE**

**⚠ WARNING:** Stop using the tool immediately if any of the following problems occur. Repairs and replacements should only be performed by an authorized technician. For any questions, please contact our customer service at (800) 232-1195, M-F 8-5 CST or email us at [techsupport@wenproducts.com](mailto:techsupport@wenproducts.com).

<b>PROBLEM</b>	<b>CAUSE</b>	<b>SOLUTION</b>
Noisy Operation or Excessive Vibration	<ol style="list-style-type: none"> <li>1) Incorrect belt tension</li> <li>2) Dry spindle</li> <li>3) Loose spindle pulley</li> <li>4) Loose motor pulley</li> <li>5) Seized motor pulley</li> </ol>	<ol style="list-style-type: none"> <li>1) Adjust the belt tension (See REPLACE THE BELT section)</li> <li>2) Lubricate the spindle</li> <li>3) Tighten the set screws on the side of the spindle pulley</li> <li>4) Tighten the set screws on the side of the motor pulley</li> <li>5) Lubricate motor pulley and motor shaft; ensure that pulley opens and closes when machine is ON and speed is adjusted.</li> </ol>
The drill bit burns or smokes	<ol style="list-style-type: none"> <li>1) Drilling at the incorrect speed</li> <li>2) The wood chips are not coming out of the hole</li> <li>3) Dull drill bit</li> <li>4) Feeding the workpiece too slowly</li> <li>5) Not lubricated</li> </ol>	<ol style="list-style-type: none"> <li>1) Change the speed</li> <li>2) Retract the drill bit frequently to clear the chips</li> <li>3) Resharpen or replace the drill bit</li> <li>4) Feed fast enough to cut the workpiece</li> <li>5) Lubricate the drill bit with cutting oil or motor oil</li> </ol>
Excessive drill run out or wobble; drilled hole is not round	<ol style="list-style-type: none"> <li>1) Bent drill bit</li> <li>2) Bit improperly installed in the chuck</li> <li>3) Worn spindle bearings</li> <li>4) Lengths of cutting flutes or angles not appropriate for the hardness of the wood grain</li> <li>5) Chuck not properly installed</li> </ol>	<ol style="list-style-type: none"> <li>1) Replace the drill bit</li> <li>2) Reinstall the bit</li> <li>3) Bearings may need replacement. Contact customer service at 1-800-232-1195</li> <li>4) Resharpen the drill bit correctly or replace with the appropriate type</li> <li>5) Reinstall the chuck</li> </ol>

## **TROUBLESHOOTING GUIDE**

**⚠ WARNING:** Stop using the tool immediately if any of the following problems occur. Repairs and replacements should only be performed by an authorized technician. For any questions, please contact our customer service at (800) 232-1195, M-F 8-5 CST or email us at [techsupport@wenproducts.com](mailto:techsupport@wenproducts.com).

<b>PROBLEM</b>	<b>CAUSE</b>	<b>SOLUTION</b>
Drill bit binds in the workpiece	<ol style="list-style-type: none"> <li>1) The workpiece is pinching the bit</li> <li>2) Excessive feed pressure</li> </ol>	<ol style="list-style-type: none"> <li>1) Support or clamp the workpiece</li> <li>2) Feed more slowly</li> </ol>
Spindle returns too slowly or too quickly	Coil spring has improper tension	Adjust the coil spring tension (see p .17)
Chuck falls off spindle	Dirt, grease, or oil on the tapered surface on the spindle or in the chuck	Clean the tapered surface of both the chuck and spindle with a household detergent
Motor will not run	<ol style="list-style-type: none"> <li>1) Defective or broken switch</li> <li>2) Defective or damaged power cord</li> <li>3) Open circuit, loose connections, or burned out motor</li> <li>4) Low voltage</li> <li>5) Bad starting capacitor</li> </ol>	<ol style="list-style-type: none"> <li>1) Contact customer service at 1-800-232-1195</li> <li>2) Contact customer service at 1-800-232-1195</li> <li>3) Contact customer service at 1-800-232-1195</li> <li>4) Check the power line for the proper voltage. Use another circuit or have a qualified electrician upgrade the service.</li> <li>5) Contact customer service at 1-800-232-1195</li> </ol>
Motor stalls	<ol style="list-style-type: none"> <li>1) Short circuit in motor</li> <li>2) Incorrect fuses or circuit breakers</li> <li>3) Overloaded circuit</li> <li>4) Low voltage</li> </ol>	<ol style="list-style-type: none"> <li>1) Contact customer service at 1-800-232-1195</li> <li>2) Replace with correct fuse or circuit breaker for the circuit</li> <li>3) Turn off other machines and retry</li> <li>4) Check the power line for the proper voltage. Use another circuit or have a qualified electrician upgrade the service.</li> </ol>

# EXPLODED VIEW & PARTS LIST

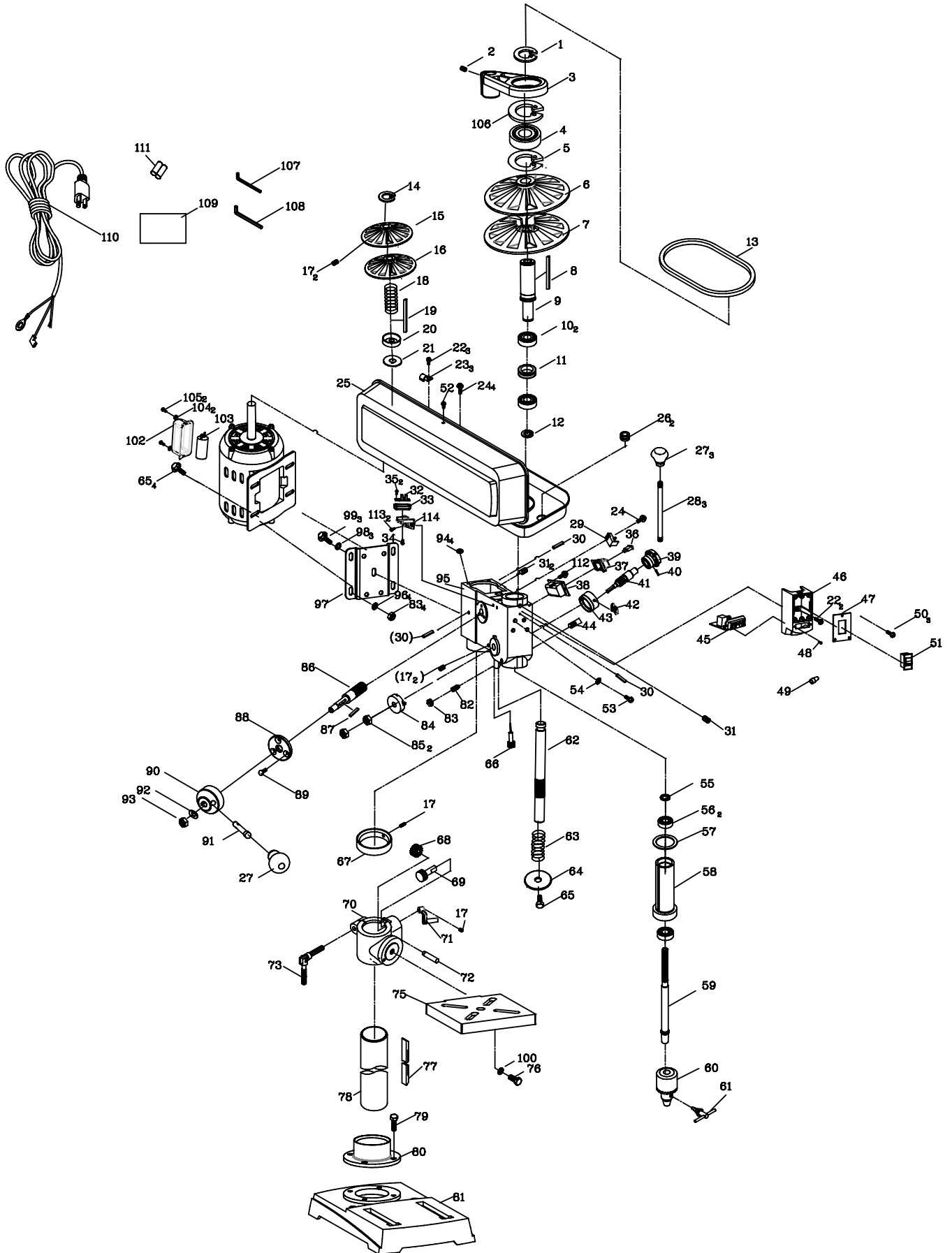



## **EXPLODED VIEW & PARTS LIST**

No.	Part No.	Description	Qty.
1	4212B-001	Retaining plate	1
2	4212B-002	Set screw, M8x12	1
3	4212B-003	Cam	1
4	4212B-004	Ball bearing, 6907Z	1
5	4212B-005	Elastic ring	1
6	4212B-006	Spindle movable pulley	1
7	4212B-007	Spindle fixed pulley	1
8	4212B-008	Key, A type, 4x4x64	1
9	4212B-009	Shaft sleeve	1
10	4212B-010	Ball bearing, 6203RZ	2
11	4212B-011	Retainer	1
12	4212B-012	Circlip, Ø17	1
13	4212B-013	V-belt, Z-800	1
14	4212B-014	Circlip, Ø14	1
15	4212B-015	Motor fixed pulley	1
16	4212B-016	Motor movable pulley	1
17	4212B-017	Hex screw	4
18	4212B-018	Motor compression spring	1
19	4212B-019	Key, A type, 4x4x84	1
20	4212B-020	Spring base	1
21	4212B-021	Spring washer	1
22	4212B-022	Screw, M5x12	3
23	4212B-023	Cord clamp	3
24	4212B-024	Screw, M6x12	4
25	4212B-025	Pulley cover assembly	1
26	4212B-026	Rubber bushing	2
27	4212B-027	Handle knob	4
28	4212B-028	Handle shaft	3
29	4212B-029	Handle fixed piece	1
30	4212B-030	Spring pin, 6-15	2
31	4212B-031	Hex screw, M8x8	2
32	4212B-032	Speed sensor	1
33	4212B-033	Speed sensor base	1
34	4212B-034	Screw, M5x6	1
35	4212B-035	Screw, S2.9x6	2
36	4212B-036	Laser switch	1
37	4212B-037	Battery housing cover	1

No.	Part No.	Description	Qty.
38	4212B-038	Battery housing	1
39	4212B-039	Handle seat	1
40	4212B-040	Spring pin, 5-15	1
41	4212B-041	Feed shaft	1
42	4212B-042	Depth locking knob	1
43	4212B-043	Scale collar	1
44	4212B-044	Screw, M6x12	1
45	4212B-045	Digital readout display	1
46	4212B-046	Switch box	1
47	4212B-047	Switch plate	1
48	4212B-048	Screw, ST4.9x16	2
49	4212B-049	Terminal	1
50	4212B-050	Screw, ST4.2x10	3
51	4212B-051	ON/OFF switch	1
52	4212B-052	Flange screw, M5x12	1
53	4212B-053	Screw, M5x8	2
54	4212B-054	Toothed washer, M5	2
55	4212B-055	Spindle circlip	1
56	4212B-056	Ball bearing, 6201Z	2
57	4212B-057	Rubber washer, 40mm	1
58	4212B-058	Quill	1
59	4212B-059	Spindle, JT33	1
60	4212B-060	Chuck, JT33	1
61	4212B-061	Chuck key	1
62	4212B-062	Rack shaft	1
63	4212B-063	Rack shaft spring	1
64	4212B-064	Washer, M8	1
65	4212B-065	Hex flange bolt	1
66	4212B-066	Laser	2
67	4212B-067	Collar	1
68	4212B-068	Internal gear	1
69	4212B-069	Worm gear	1
70	4212B-070	Table support	1
71	4212B-071	Crank handle	1
72	4212B-072	Inner gear shaft	1
73	4212B-073	Table lock handle	1
75	4212B-075	Table	1
76	4212B-076	Hex bolt, M12x25	1
77	4212B-077	Rack	1

## **EXPLODED VIEW & PARTS LIST**

No.	Part No.	Description	Qty.
78	4212B-078	Column	1
79	4212B-079	Hex bolt, M8x25	3
80	4212B-080	Column base	1
81	4212B-081	Base	1
82	4212B-082	Quill set screw, M8x20	1
83	4212B-083	Hex nut, M8	5
84	4212B-084	Coil spring assembly	1
85	4212B-085	Hex nut, 3/8x24 UNF	2
86	4212B-086	Gear shaft	1
87	4212B-087	Key, A type, 3x3x25	1
88	4212B-088	Speed adjustment base	1
89	4212B-089	Phillips-head screw, M5x25	3
90	4212B-090	Variable speed handle seat	1
91	4212B-091	Variable speed handle	1
92	4212B-092	Butterfly spring	1
93	4212B-093	Hex nut M10	1
94	4212B-094	Washer	4

No.	Part No.	Description	Qty.
95	4212B-095	Head	1
96	4212B-096	Flat washer, M8	4
97	4212B-097	Motor plate	1
98	4212B-098	Spring washer, M8	3
99	4212B-099	Hex bolt, M8x10	3
100	4212B-100	Spring washer, M12	1
102	4212B-102	Capacitor cover	1
103	4212B-103	Capacitor	1
104	4212B-104	Flat washer, M4	2
105	4212B-105	Screw, M4x6	2
106	4212B-106	Circlip for shaft Ø35	1
107	4212B-107	Hex wrench, M3	1
108	4212B-108	Hex wrench, M4	1
109	4212B-109	Manual	1
110	4212B-110	Power cord	1
111	4212B-111	AA battery	2
112	4212B-112	Screw, M4x8	1
113	4212B-113	Screw, M5x8	2
114	4212B-114	Counter base	1

## **WARRANTY STATEMENT**

WEN Products is committed to building tools that are dependable for years. Our warranties are consistent with this commitment and our dedication to quality.

### **LIMITED WARRANTY OF WEN CONSUMER POWER TOOLS PRODUCTS FOR HOME USE**

GREAT LAKES TECHNOLOGIES, LLC (“Seller”) warrants to the original purchaser only, that all WEN consumer power tools will be free from defects in material or workmanship for a period of two (2) years from date of purchase. Ninety days for all WEN products if the tool is used for professional or commercial use.

SELLER’S SOLE OBLIGATION AND YOUR EXCLUSIVE REMEDY under this Limited Warranty and, to the extent permitted by law, any warranty or condition implied by law, shall be the repair or replacement of parts, without charge, which are defective in material or workmanship and which have not been misused, carelessly handled, or misrepaired by persons other than Seller or Authorized Service Center. To make a claim under this Limited Warranty, you must make sure to keep a copy of your proof of purchase that clearly defines the Date of Purchase (month and year) and the Place of Purchase. Place of purchase must be a direct vendor of Great Lakes Technologies, LLC. Third party vendors such as garage sales, pawn shops, resale shops, or any other secondhand merchant void the warranty included with this product. Contact [techsupport@wenproducts.com](mailto:techsupport@wenproducts.com) or 1-800-232-1195 to make arrangements for repairs and transportation.

When returning a product for warranty service, the shipping charges must be prepaid by the purchaser. The product must be shipped in its original container (or an equivalent), properly packed to withstand the hazards of shipment. The product must be fully insured with a copy of the warranty card and/or the proof of purchase enclosed. There must also be a description of the problem in order to help our repairs department diagnose and fix the issue. Repairs will be made and the product will be returned and shipped back to the purchaser at no charge.

THIS LIMITED WARRANTY DOES NOT APPLY TO ACCESSORY ITEMS THAT WEAR OUT FROM REGULAR USAGE OVER TIME INCLUDING BELTS, BRUSHES, BLADES, ETC. ANY IMPLIED WARRANTIES SHALL BE LIMITED IN DURATION TO TWO (2) YEARS FROM DATE OF PURCHASE. SOME STATES IN THE U.S., SOME CANADIAN PROVINCES DO NOT ALLOW LIMITATIONS ON HOW LONG AN IMPLIED WARRANTY LASTS, SO THE ABOVE LIMITATION MAY NOT APPLY TO YOU.

IN NO EVENT SHALL SELLER BE LIABLE FOR ANY INCIDENTAL OR CONSEQUENTIAL DAMAGES (INCLUDING BUT NOT LIMITED TO LIABILITY FOR LOSS OF PROFITS) ARISING FROM THE SALE OR USE OF THIS PRODUCT. SOME STATES IN THE U.S. AND SOME CANADIAN PROVINCES DO NOT ALLOW THE EXCLUSION OR LIMITATION OF INCIDENTAL OR CONSEQUENTIAL DAMAGES, SO THE ABOVE LIMITATION OR EXCLUSION MAY NOT APPLY TO YOU.

THIS LIMITED WARRANTY GIVES YOU SPECIFIC LEGAL RIGHTS, AND YOU MAY ALSO HAVE OTHER RIGHTS WHICH VARY FROM STATE TO STATE IN THE U.S., PROVINCE TO PROVINCE IN CANADA AND FROM COUNTRY TO COUNTRY.

THIS LIMITED WARRANTY APPLIES ONLY TO PORTABLE ELECTRIC TOOLS, BENCH POWER TOOLS, OUTDOOR POWER EQUIPMENT AND PNEUMATIC TOOLS SOLD WITHIN THE UNITED STATES OF AMERICA, CANADA AND THE COMMONWEALTH OF PUERTO RICO. FOR WARRANTY COVERAGE WITHIN OTHER COUNTRIES, CONTACT THE WEN CUSTOMER SUPPORT LINE.

**THANKS FOR  
REMEMBERING**

