

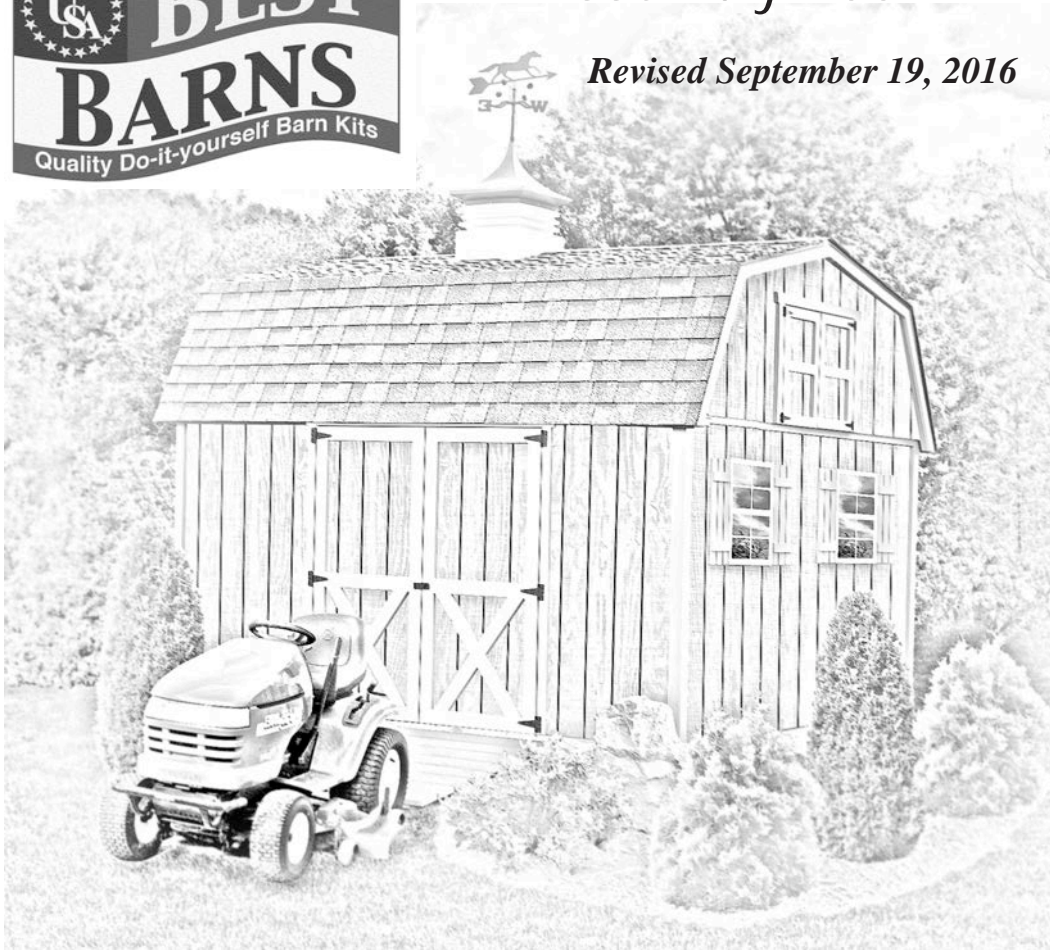

Best Barns USA Assembly Book

Revised September 19, 2016



the Meadowbrook-R **12' x 10'**

Manufactured by Reynolds Building Systems, Inc.

205 Arlington Drive Greenville, PA 16125 724-646-3775

This manual is copyrighted. Under the copyright laws, this manual may not be copied, in whole or in part, without consent from Reynolds Building Systems, Inc. © Copyright 2011

IMPORTANT INFORMATION ABOUT YOUR SHED KIT

This manual will show the assembly for the 12' x 10' Meadowbrook building kit. **If you received duplicate books, use the one with the latest revision date.**

The foundation size should measure 10'-0" deep by 11'-9" long. **Do Not** make the foundation larger than the building size. The siding should project beyond the foundation for water to expel properly from the sidewalls.

Read the instructions before starting the assembly of the building. If you have any questions about assembling the kit, call 800-245-1577. Business hours (8:00-5:00 ET) Monday thru Friday. After business hours call 724-866-HELP (4357) or email to help@barnkits.com.

The material that is included in our kit is listed on the back page. The optional floor package, if purchased, will be supplied by a local lumber supplier.

Our kit does not include the shingles, the quantity needed is listed under Step 14. The siding is primed. You will need to apply a finish coat using latex acrylic paint.

Some of the framing lumber was used in the shipping pallet. Unpack the material from the pallets, then unscrew the OSB sheathing, it will be used for the loft flooring. Unscrew the 2x4s from the shipping pallet. This material will be used for wall bracing and wall plates. The bit for the screws is packed in the hardware bag.

Stacking the boards, according to size, will make them easier to find when needed. Some boards have colored ends. All the 72" long 2x4s have black ends, stack these boards together.

Before you begin construction, be sure to study this assembly manual. Also, obtain a building permit and check all pertinent building code regulations.

Thank you for your purchase.

Bill & Linda Rinella, owners

The siding is made in 4x8 sheets with grooves cut into the face, the long edge is beveled so that the siding overlays where they butt.

To identify which edge we want you to use, we will refer to the edge as either the 'LAP' Edge or the Tongue Edge. Nail siding with 8d galv. nails, spaced 12" apart.

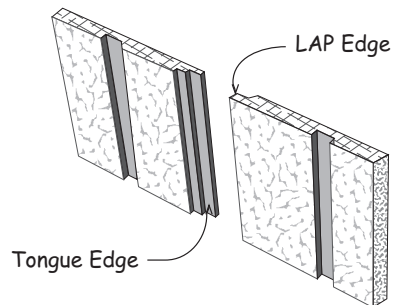

Tool List

- | | |
|--|--|
| <input type="checkbox"/> Hammer & Phillips Screwdriver | <input type="checkbox"/> Power Drill/Screwdriver |
| <input type="checkbox"/> Framing Square & Level | <input type="checkbox"/> Measuring Tape |
| <input type="checkbox"/> Hand or Circular Saw | <input type="checkbox"/> 2 - 8' Step Ladders |

Always wear safety glasses when cutting or nailing!

Constructing Details for Deluxe Floor System

Deluxe floors include 4x4 runners, standard floors do not

Foundation size is 10'-0" x 11'-9". Check local building codes in your area, the construction may have to change. For a concrete slab, install sill sealer as a moisture barrier between the concrete and the wall plates. Foam sill sealer can be purchased at home centers in rolls 3-1/2" or wider.

1. Cut joist headers to floor length. See Below.

Layout for 16" on center joist spacing. 'X' marks where floor joist will be placed.

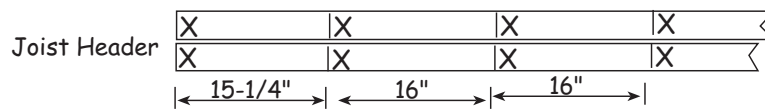

2. Cut 2x4-10' floor joist to 9'-9". *Treated lumber may be thicker than 1-1/2". Take this into account when cutting the length of floor joists. Shorten joist measurements if necessary to obtain 10'-0" building width.*

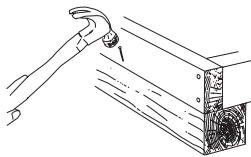
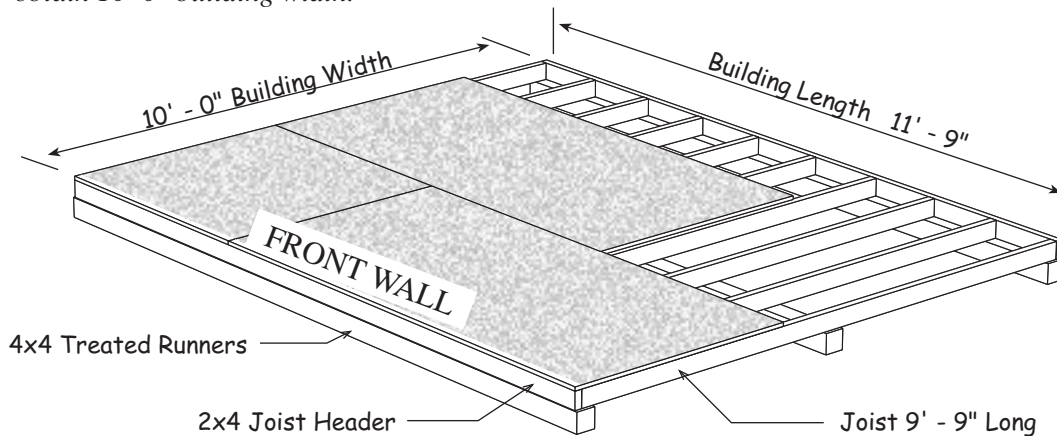

Nail the 2x4s to the 4x4 runners to keep the 2x4 frame from moving.

It is important that the floor be level and square. Before nailing the flooring, measure the floor diagonally (corner to corner). Then measure the opposite corners. These measurements will be the same if the floor is square.

| Material Description | 10' x 12' shed | 10' x 16' shed |
|-----------------------|----------------|----------------|
| 2x4 Joist Headers | 2 pcs. 12' | 2 pcs. 16' |
| 2x4 Floor Joist | 10 pcs. 10' | 13 pcs. 10' |
| 4x4 Treated Runners | 3 pcs. 12' | 6 pcs. 8' |
| Flooring 5/8" or 3/4" | 4 pcs. 4x8 | 5 pcs. 4x8 |
| Screw Floor Nails | 1 lb. 8d | 2 lb. 8d |
| Galv. Box Nails | 1 lb. 16d | 1 lb. 16d |

Step 1 Assemble Trusses

1. Position (2) two truss halves together so that a 116-1/4" long 2x4 bottom cord may be placed between them.
2. Hold truss parts in place by temporarily screwing 2x4 blocks to the floor. There are short 2x4 blocks supplied in the kit for this purpose. Use 2-1/2" wood screws.
3. Secure the tops together with a 22-3/4" long ridge block and wood gusset. Nail the gusset with (16) sixteen 6d common nails. Space nails evenly.
4. Secure the truss bottom legs to the bottom cord with wood gussets. **Note:** You may have to spread the truss bottom to fit the bottom 2x4. Use 12 nails per gusset. Space nails evenly.
5. Assemble (3) three more trusses.
6. Turn trusses over and apply wood gussets to the opposite side.

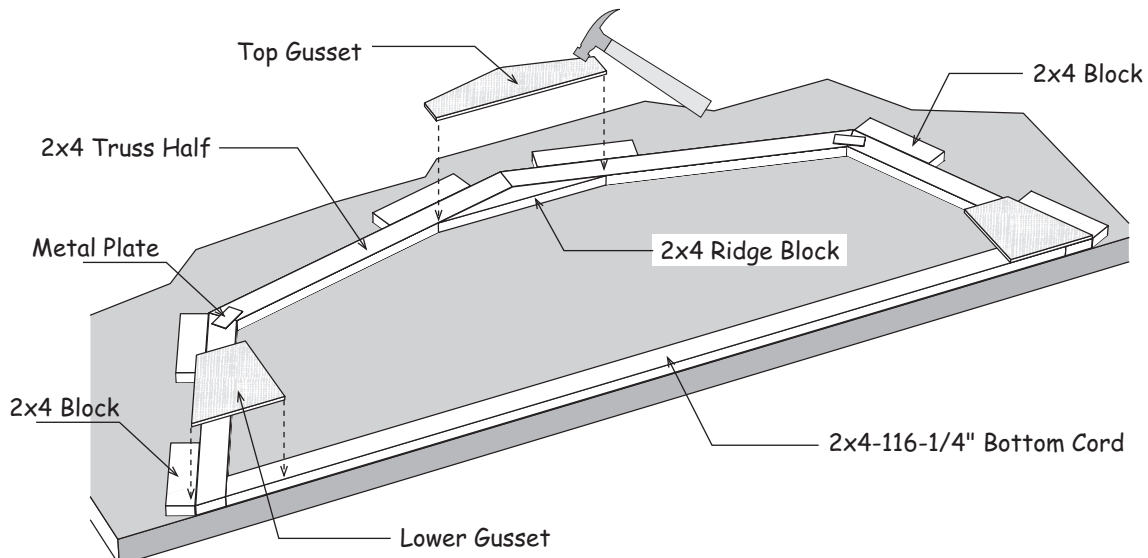

7. Assemble another truss without a bottom cord. Locate wood gussets with a 2x4 block attached to one side.
8. Attach this block/gusset to the bottom of each truss leg. Secure to leg with 6d common nails.
9. Turn truss over and apply gussets.

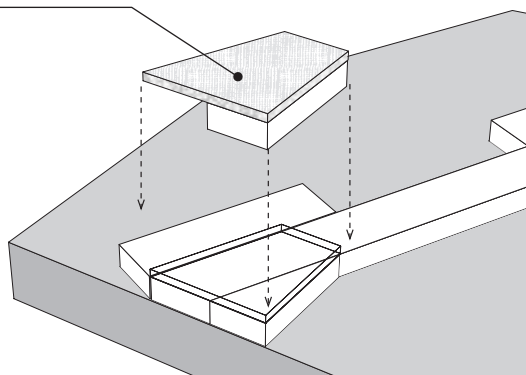

Do Not remove blocks from floor until **Step 2** is completed.

Step 2 Assemble Roof Gable Without Loft Doors

1. Place (2) two truss halves in jig. Position ridge block at peak. Locate (1) one 35-3/4" 2x4 center stud and secure to ridge block with 1"x4" metal plate. Nail gusset to ridge block and truss.
2. Install 116-1/4" bottom cord and nail gussets to bottom of truss.
3. Install (2) two 21-1/2" and (2) two 34-1/4" with angle cut on one end. Secure 2x4 gable studs to the truss with (9) nine 1"x4" metal plates at top and bottom.

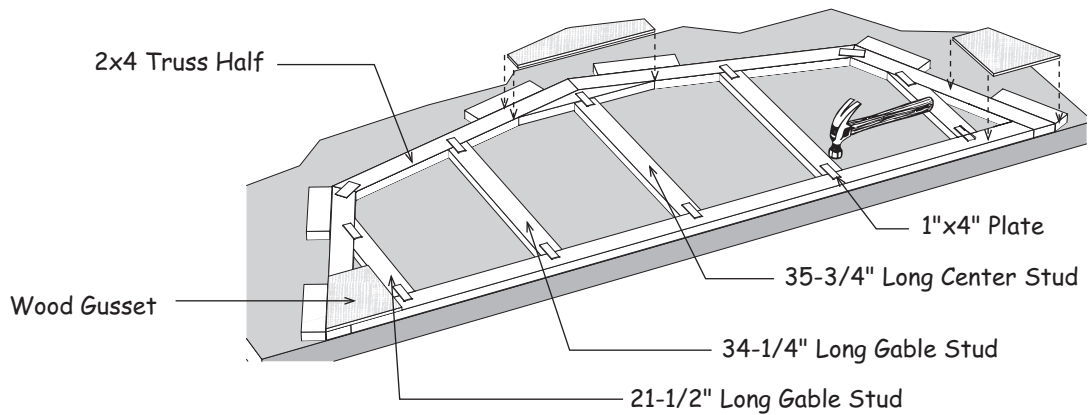

4. Screw (3) three 16" long 2x4 blocks flush with bottom of the 2x4 bottom cord. One on each end and one in the center. Use (2) two 2-1/2" screws.

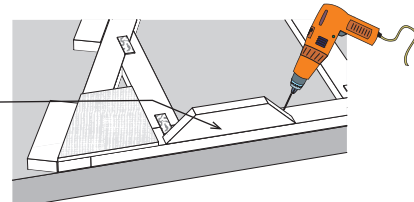

5. Turn the gable over. Locate pre-cut gable siding. Starting from left install the siding extending 3/4" below the bottom 2x4. Insure the siding does not extend above the top frame. Use 6d galv. nails spaced 12" apart.

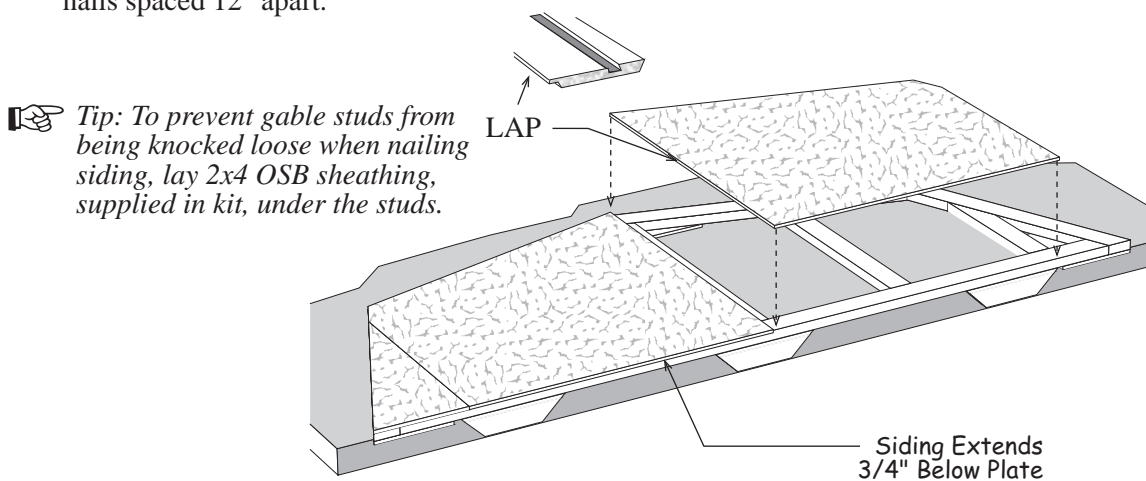

Step 3 Install Rear Gable Overhang & Trim

1. Apply 47" long 2x3 boards to the gable. These boards have a blue marking on one end. Install this end at the peak. Install boards flush with the top of the gable frame. Use 10d sinkers.
2. Install a 42-1/4" long 2x3 at the sides of the gable, flush with the frame. Board will extend below siding.

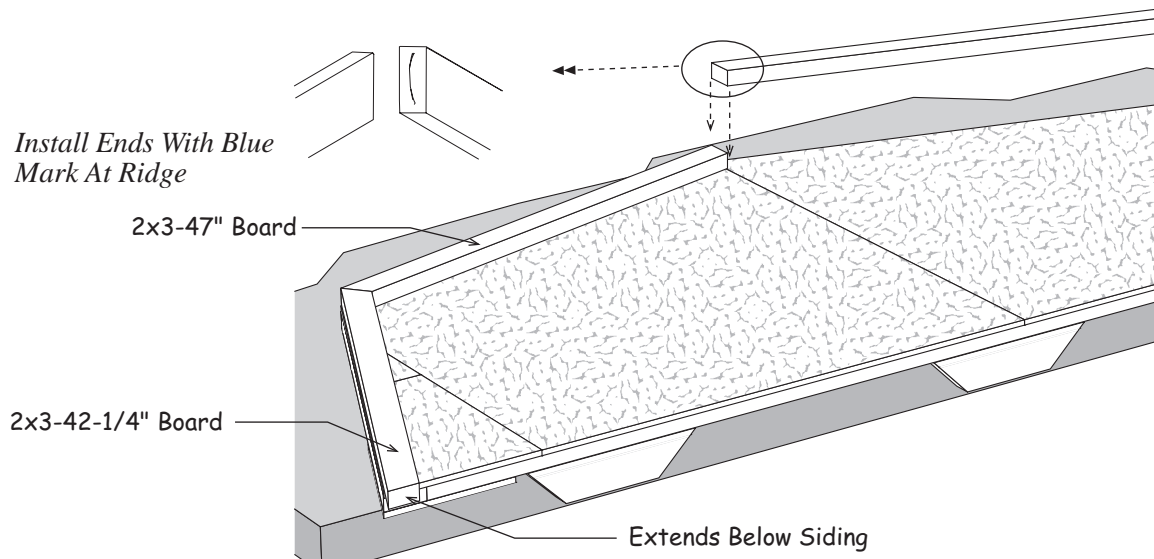

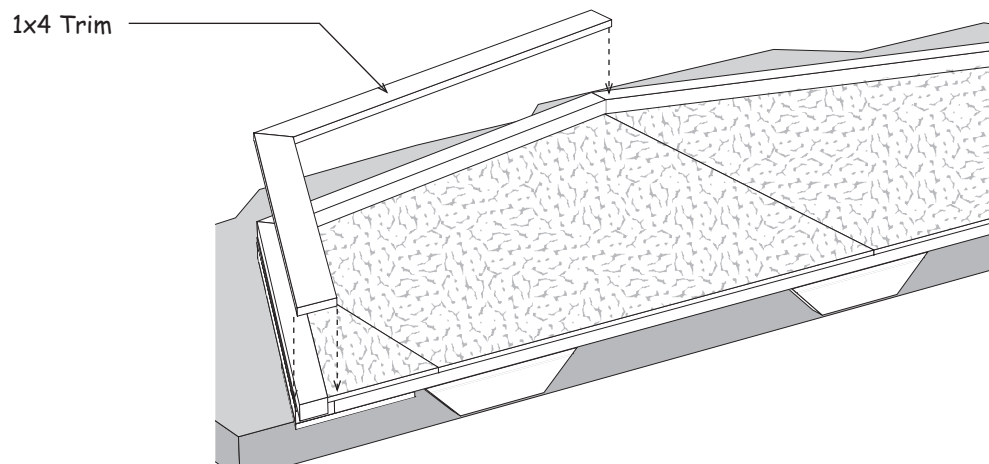

3. Apply 1x4 white pine trim to gable. Install a 47-1/2" long 1x4 at the top of the gable. These boards have a blue marking on one end. Install this end at the peak. Install the 1x4 gable trim extending 1/2" above the siding on the gable. When installed later, the roof sheathing will be flush with the top of the trim.
4. Install a 43" long 1x4 at the sides of the gable.

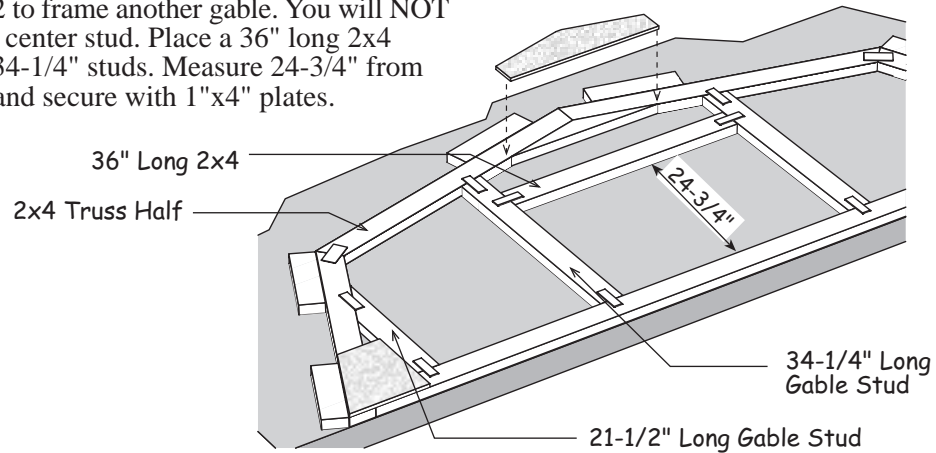

Step 4 Assemble Roof Gable With Loft Doors

1. Repeat Step 2 to frame another gable. You will NOT use a 35-3/4" center stud. Place a 36" long 2x4 between the 34-1/4" studs. Measure 24-3/4" from bottom cord and secure with 1"x4" plates.



 *If you don't need loft access from the outside, attach loft door frames to the gable to create a decorative look and weather tight storage area.*

2. Turn the gable over. Lay out the first (2) two pieces of siding on frame. **Important: Do not nail to frame.** Mark and cut so siding is flush with top and left side of opening. Cut to bottom of siding below gable plate. Nail first two pieces of siding to frame. Lay out next siding panel, do not nail, and repeat cut for right side door opening. Nail last two pieces of siding to frame.

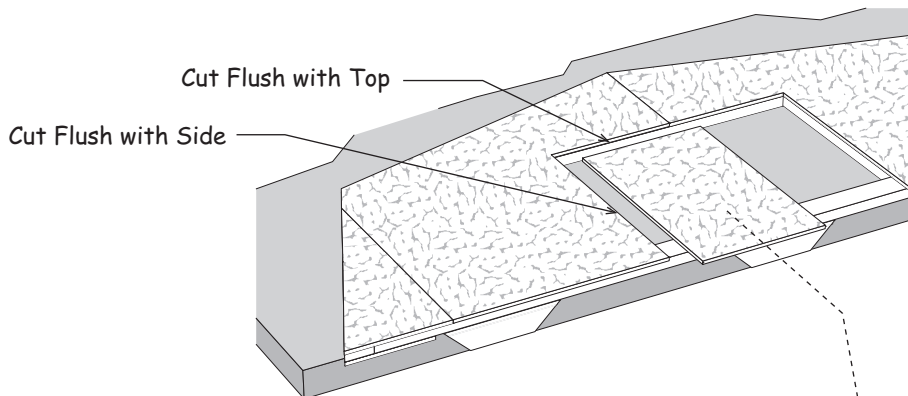

3. Assemble the loft doors. The loft door frames are temporarily held together with corrugated fasteners, this is the back side of the door frame. Place the doors on level surface, face side down. Cut the siding from above step to the size of the door frame. Secure the siding panel to the frame with 1" screws provided.

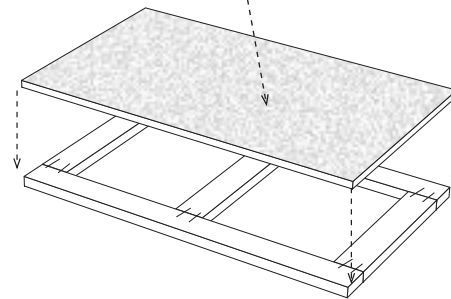

Step 5 Install Gable Trim & Loft Doors

1. Apply 47" long 2x3 boards to the gable. These boards have a blue marking on one end. Install this end at the peak. Install boards flush with the top of the gable frame.
2. Install a 42-1/4" long 2x3 at the sides of the gable, flush with the frame.
3. Install 29-1/4" long 1x3 trim boards on each side of the loft door opening. Install a 43" long trim board across the top.
4. Install loft doors using 4" hinges and 1-1/4" long hinge screws. The screws have a square head. The bit is packed with the screws. Install barrel bolts to the inside top of the doors to secure doors when closed. When door is closed mark where bolt will hit 2x4 gable frame. You will need to drill a 1/4" hole into the underside of the 2x4.

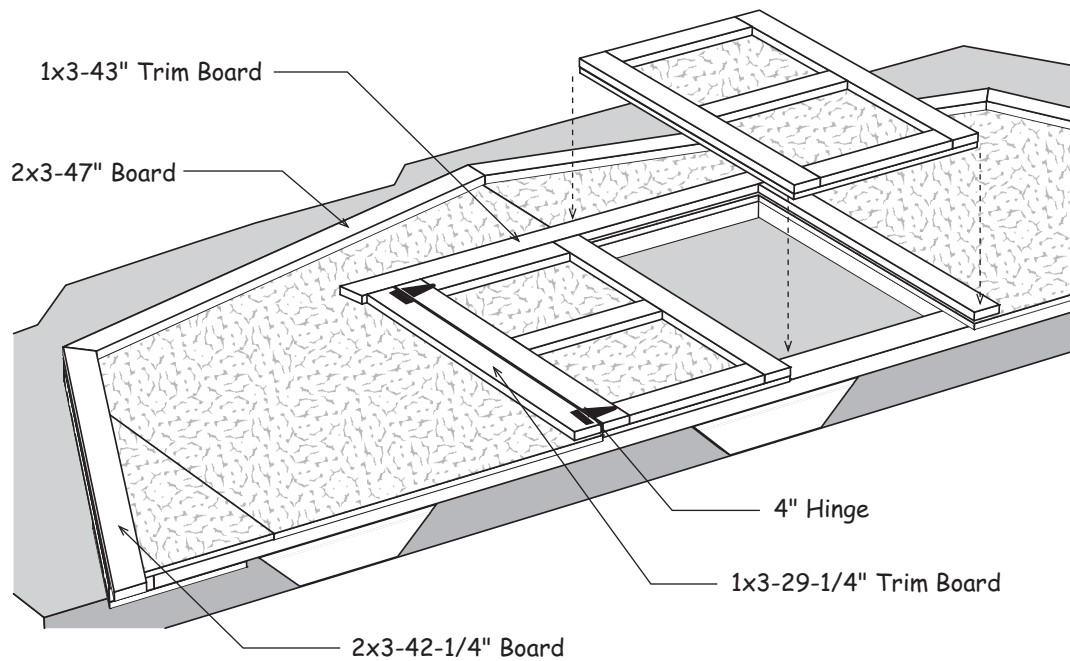

5. Apply 1x4 white pine trim to gable. Install a 47-1/2" long 1x4 at the top of the gable. These boards have a blue marking on one end. Install this end at the top. Install trim flush with the top of the gable frame. Use 8d galv. nails.
6. Install a 43" long 1x4 at the sides of the gable, flush with the frame.

Step 6 Assemble Back Wall

1. Position 68-1/2" and 65-1/2" long 2x4 boards together and indicate where the wall studs will be located. Mark the ends that will butt together with the letters 'A' and 'B'.

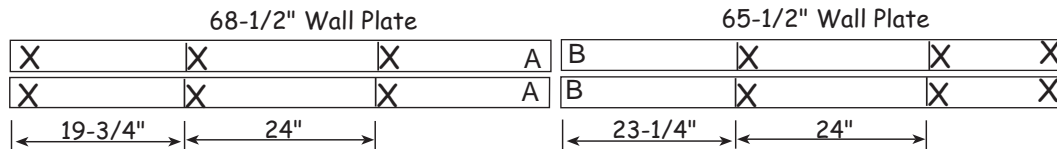

2. Install 72" long wall studs, between the wall plates, over the 'X' marks and where the plates meet. Use (2) two 10d sinkers at each end of stud. Nail wall frames together using 10d sinkers.
3. For a 12' long building, cut a 70-1/2" long 2x6 board in half so the center 2x6 tie plate will span where the sidewalls meet..
4. Install (2) two 35-1/4" and a 70-1/2" long 2x6 boards as tie plates over the top plate. The 2x6s will extend 3-1/2" beyond the end of the wall frame.

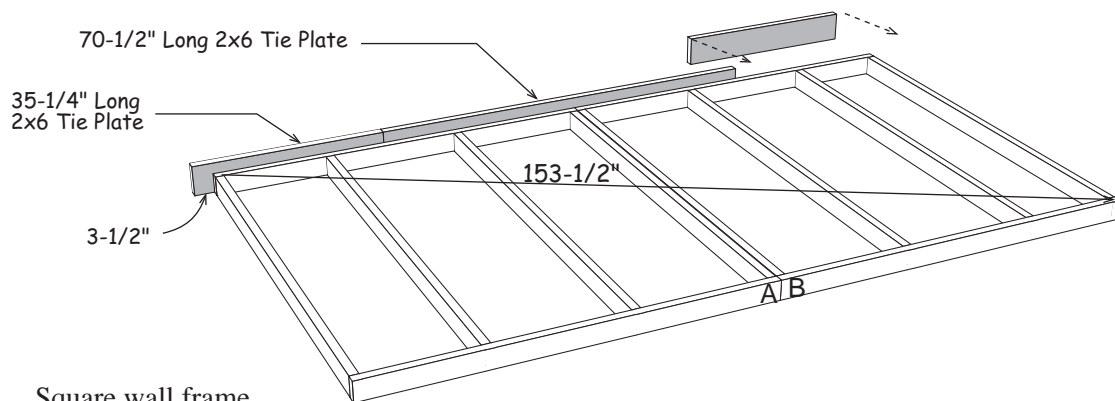

5. Square wall frame.
6. Locate (3) full width x 75-3/4" siding panels. Install the first siding panel with the 'LAP' edge extending 3-1/2" beyond the wall frame. Use the 8d galv. nails spaced 12" on center.
7. Install a full width siding panel in the center.
8. Measuring from 'LAP' edge cut last panel to a width of 45". Install so siding extends 3-1/2" past wall frame.

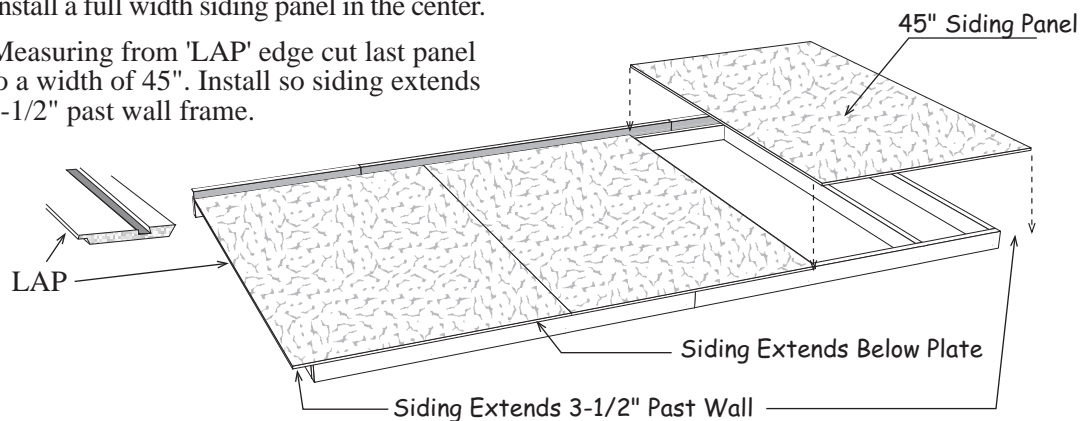

Step 7 Assemble Front Wall Panel

 Assemble door header jacks and door spacer to aid in the door wall assembly.

1. Cut (2) two 2x4-6' to a length of 69-1/2".
2. Assemble a door header jack by nailing a 69-1/2" long 2x4 to a 72" long 2x4. Use 10d sinkers.
3. Assemble another door jack.
4. Butt a 68-1/2" long 2x4 and a 65-1/2" long 2x4 together as shown below. **Important:** to keep the 2x4 aligned straight, place the 2x4 against a straight object. The top of the back wall, from **Step 6**, would be ideal.
5. Locate a 2x4 that was removed from the shipping pallet. Cut this 2x4 to a length of 64-1/2".

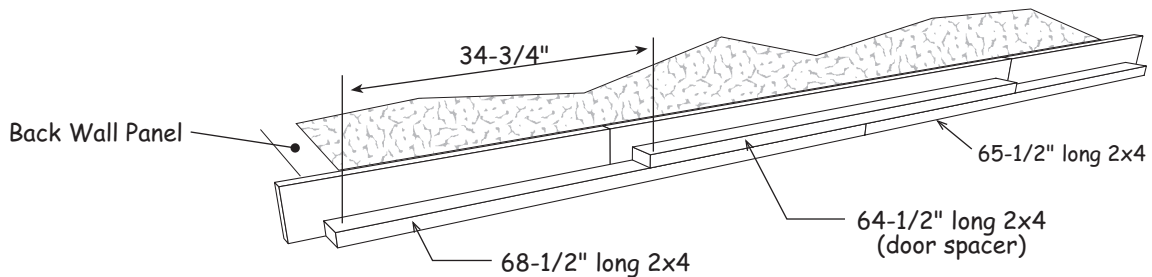
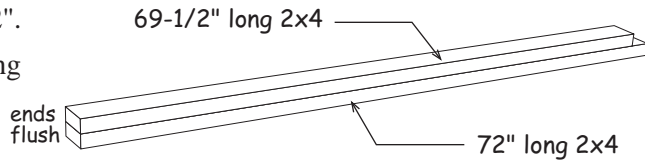

6. Install the 64-1/2" long 2x4, centered over the bottom 2x4s. The bottom 2x4s will extend 34-3/4" beyond the top 2x4 door spacer on both ends.
7. Gather 2x4s and components shown below and assemble the door wall. Use 10d sinkers.

8. Install (4) four wall studs between the top and bottom wall plates.

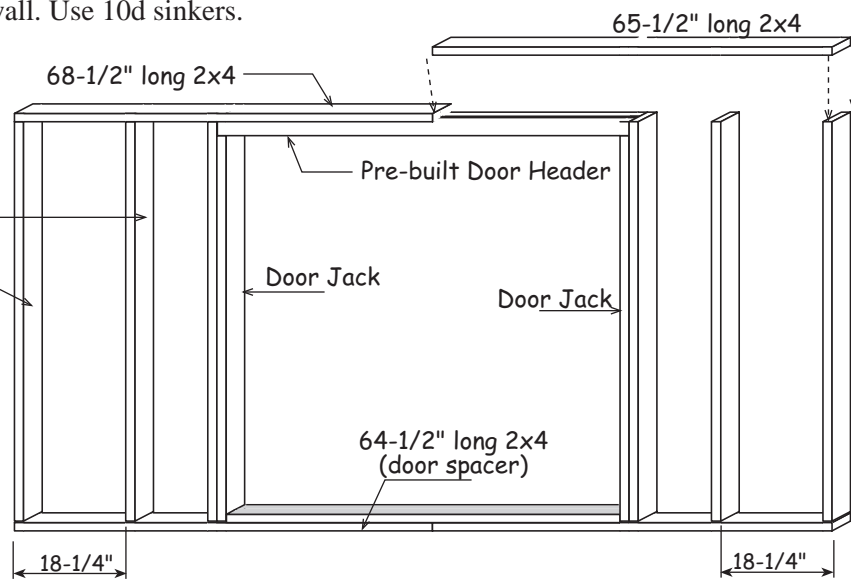

Step 7 Assemble Front Wall Panel Continued

- For a 12' long building, cut a 70-1/2" long 2x6 board in half. Install one of the 2x6 boards so the left end is extending 3-1/2" beyond the wall frame.
- Install a 70-1/2" long and the cut off from above. The end 2x6 will extend 3-1/2" beyond the wall frame.

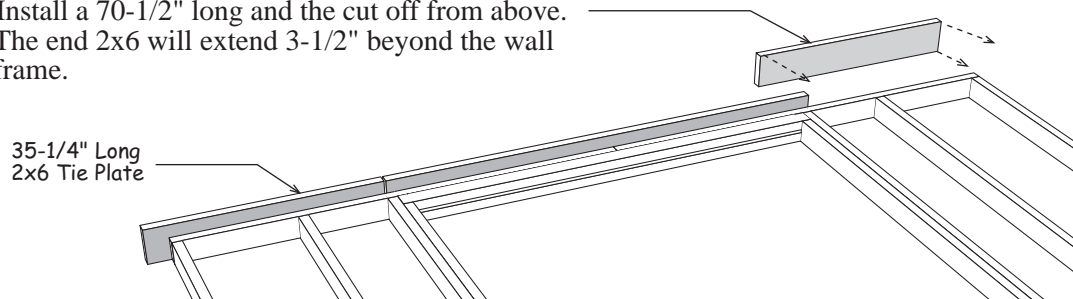

- Cut (2) two 32-1/4" x 6" siding panels to a height of 4-1/2".
- Locate a 16" wide siding panel that has a 'LAP' edge. Cut the siding to 75-3/4" length. Position the 'cut' edge flush with the left side of the door opening. Do not nail the LAP edge until the 'left' siding panel is applied.
- Cut a full width siding panel width to 22-1/2", *measuring from the 'Tongue' edge*. Install the panel with the 'cut' edge extending 3-1/2" beyond the left end of the wall frame.
- Cut another 16" wide panel to a length of 75-3/4" and install with the 'cut' edge flush with the right side of the door opening.
- Install the 4-1/2" siding panels over the door opening.
- Cut the cutoff siding panel, from step number 13, to extend 3-1/2" beyond the wall frame.

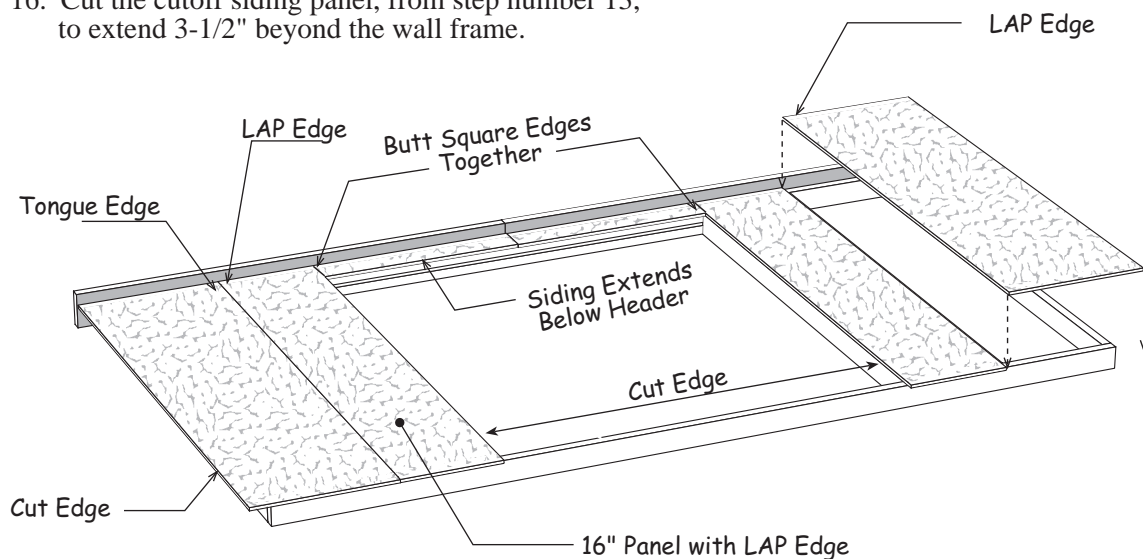

Step 8 Assemble End Walls

1. Position (2) two 2x4-10' boards together and indicate with 'X' marks, where the wall studs will be located.

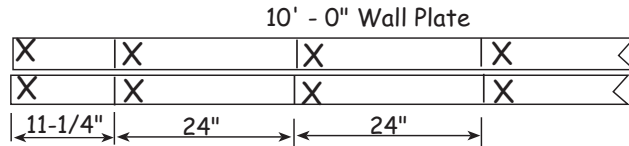

2. Install 72" wall studs between the top and bottom plates.
3. Install (2) two 56-1/2" long 2x4s as tie plates over the top plate. The 2x4s will be 3-1/2" short of the end of the wall frame.

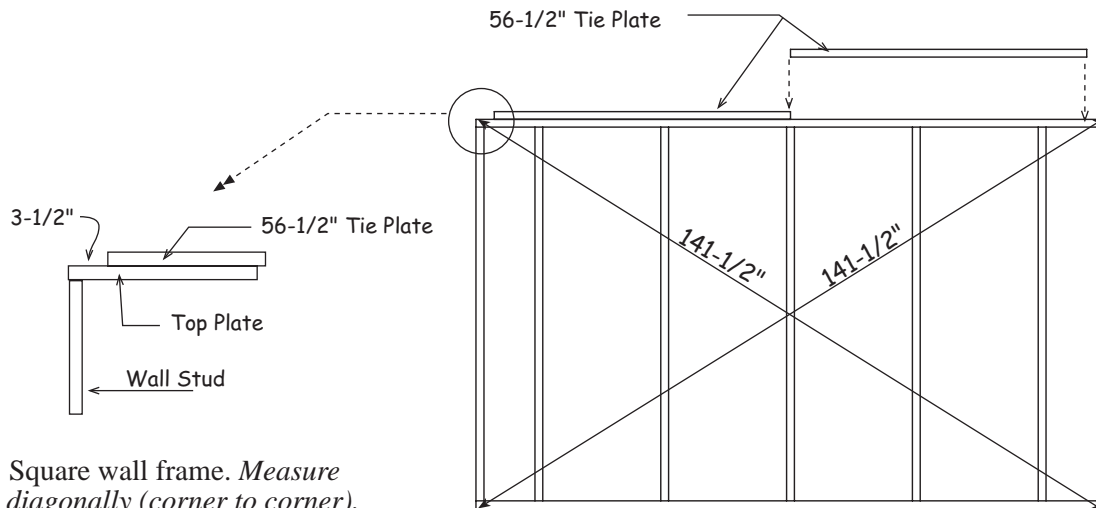

4. Square wall frame. *Measure diagonally (corner to corner).*
5. Locate a 36-3/4" x 77-1/4" siding panel with the 'Tongue' edge. Install the siding panel on the left corner, with the 'cut' edge flush with the end of the wall and flush with the top of the 2x4 tie plate. The siding should extend below the bottom plate.
6. Install a 48-3/4" x 77-1/4" siding panel in the center of the wall frame.
7. Install a 36" x 77-1-4" panel with the 'LAP' edge last.

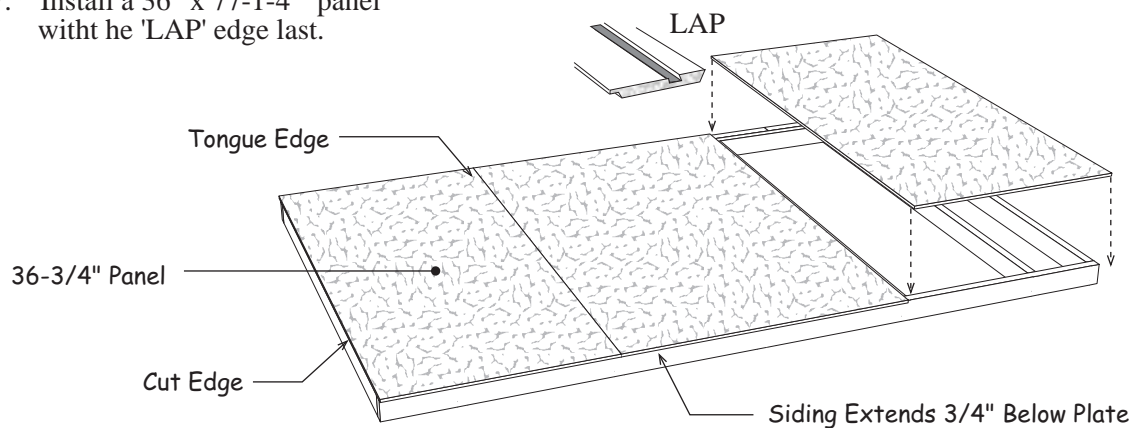

Step 8 Assemble End Walls Continued

- Repeat step numbers 1 thru 3 on previous page to assemble another end wall frame
- Install siding panels as shown below.

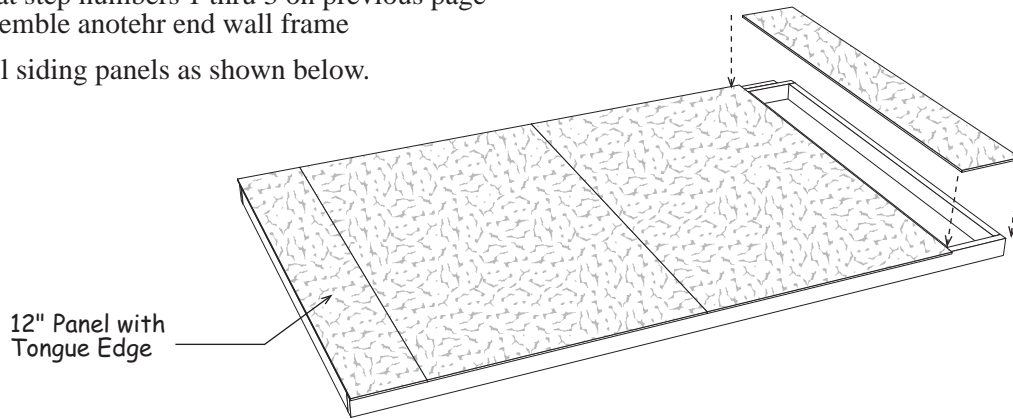

Step 9 Set Lower Walls

- Secure wall panels together at the corners. Use (4) four 10d coated nails per corner. Nail wall panels to the floor. Nail through the bottom plate. Space 10d sinkers 24" apart.
- Install (2) two 1x4-72" boards along each side of the door opening, flush with the bottom edge of the siding. Tack these boards with a couple nails; you may want to move the trim later when you install the doors. Use 8d galv. nails.
- Install a 1x3-72" board across the top of the side trim.

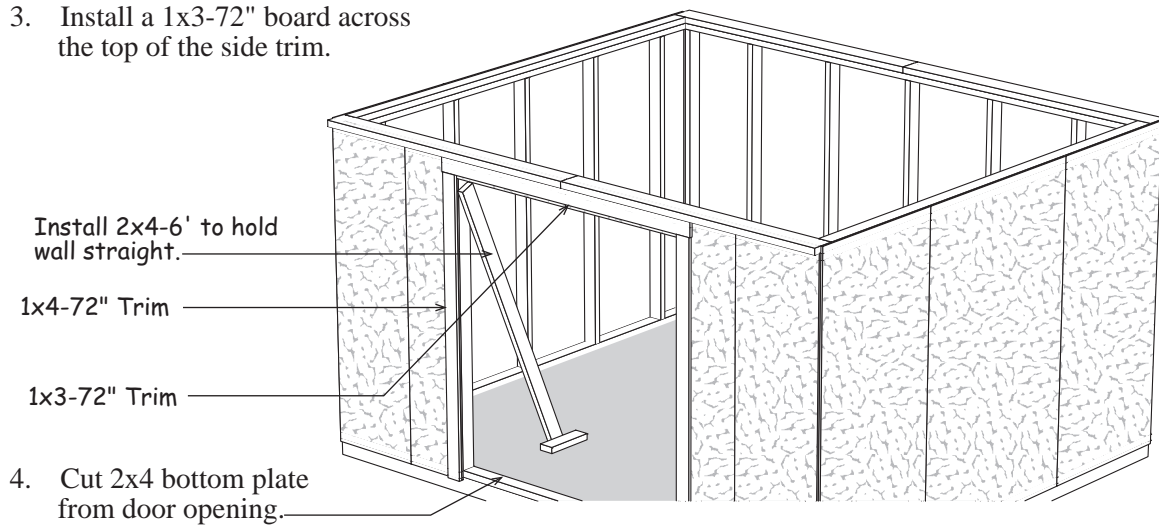

Step 10 Install Trim

1. Install (2) two 1x3-62" long trim boards flush with the top of the front wall. Use 8d galv. nails.
2. Install 1x4-75 3/4" trim boards at the corners of the front and back. Install the trim flush with siding on the end wall.
3. Install 1x4x74-3/4" trim boards at the corners of the front wall.

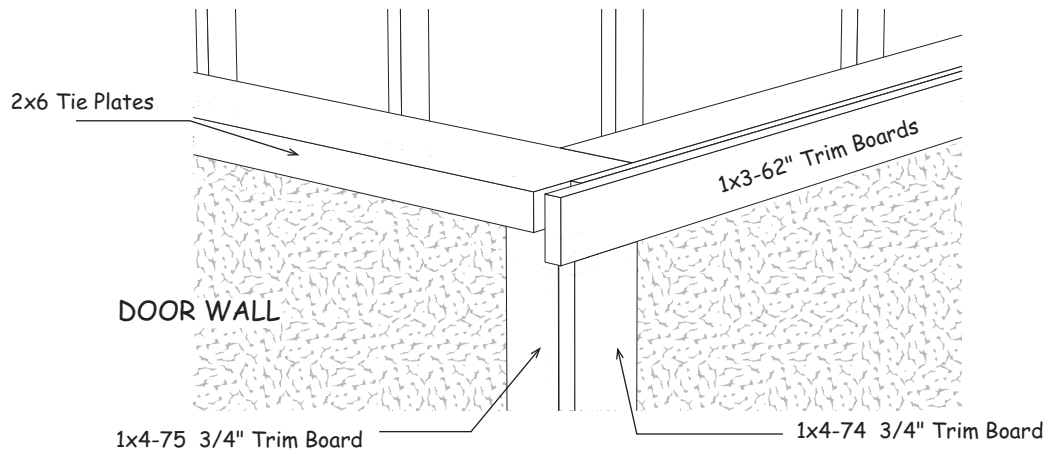

Step 11 Set Left Gable

1. Install the gable on the left end wall. The gable siding will extend over the 1x3 trim on the lower wall. **NOT behind the trim!** Secure gable to wall by nailing through the gable blocks with 10d sinkers. Nail siding along the 1x3 trim board with 6d galv. nails.

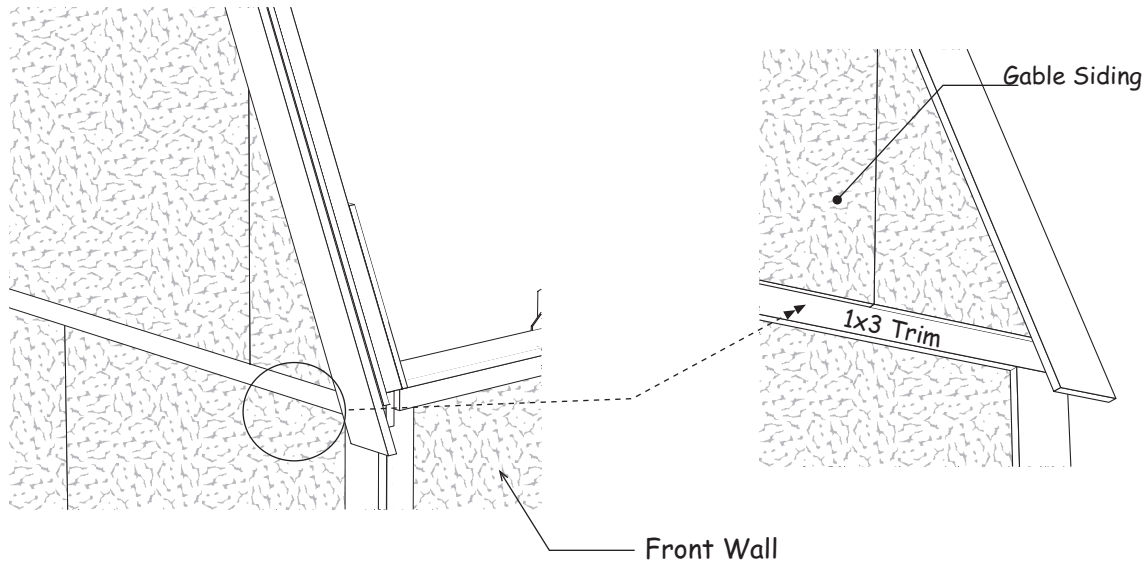

Step 12 Set Trusses

1. Layout the truss spacing on the front wall. Start at the left corner of the building. Measure from the inside face of the wood gusset when marking the location of the first truss. See next page.
2. Locate the truss hangers, there are left and right hangers. Select the right hangers.
3. Using 1-1/2" hanger nails, install the right hangers to the 2x6 tie plate. The top hanger flange should line up with the 'X' mark.

Important: When marking the back wall, use the left hangers and place the 'X' mark on the same side of the line so your trusses are parallel when they are installed.

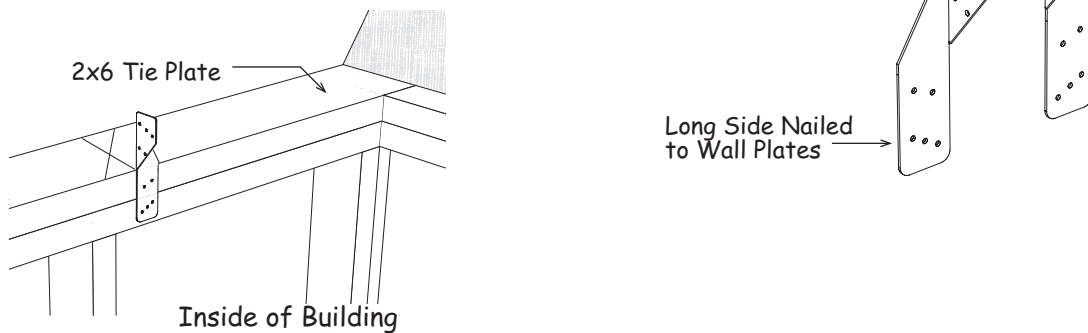

Step 12 Set Trusses Continued

4. Install the trusses over the 'X' marks. Install hanger to the opposite side of the trusses. Secure truss to metal hangers using 1-1/2" hanger nails.

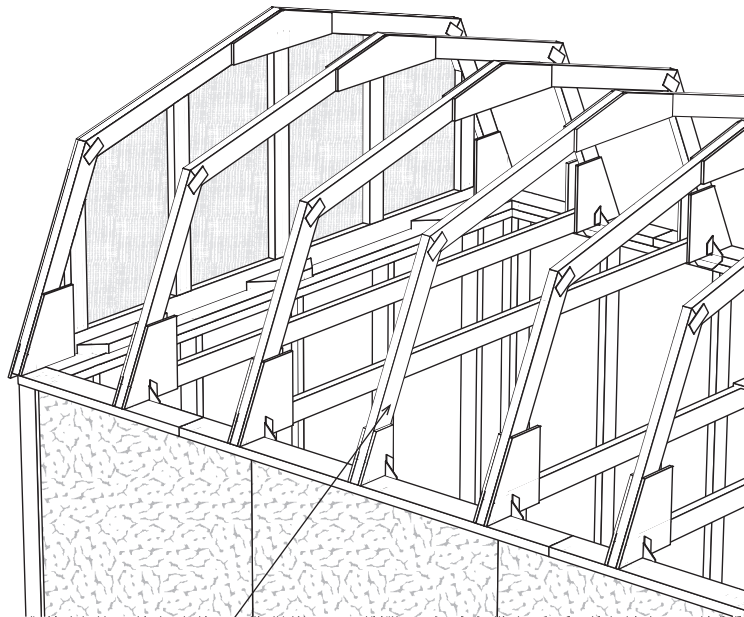
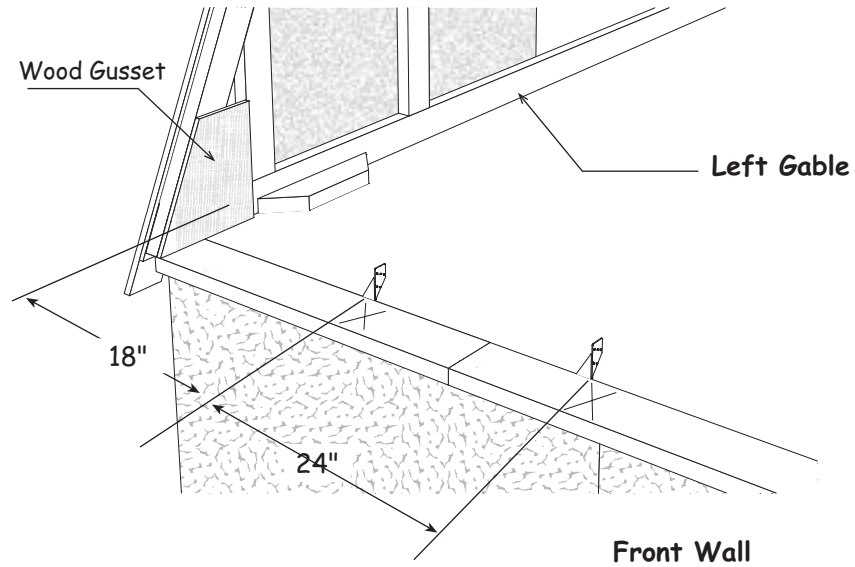

 Note: The center truss will not have a bottom cord.

Step 13 Install Trusses & Loft Floor

1. Install front gable.
2. Install OSB loft flooring over the rear and front trusses. Notch the flooring around the gable studs on the rear and front gables. Secure floor with 7d sinkers. Note: Some OSB panels may be attached to the shipping pallet.

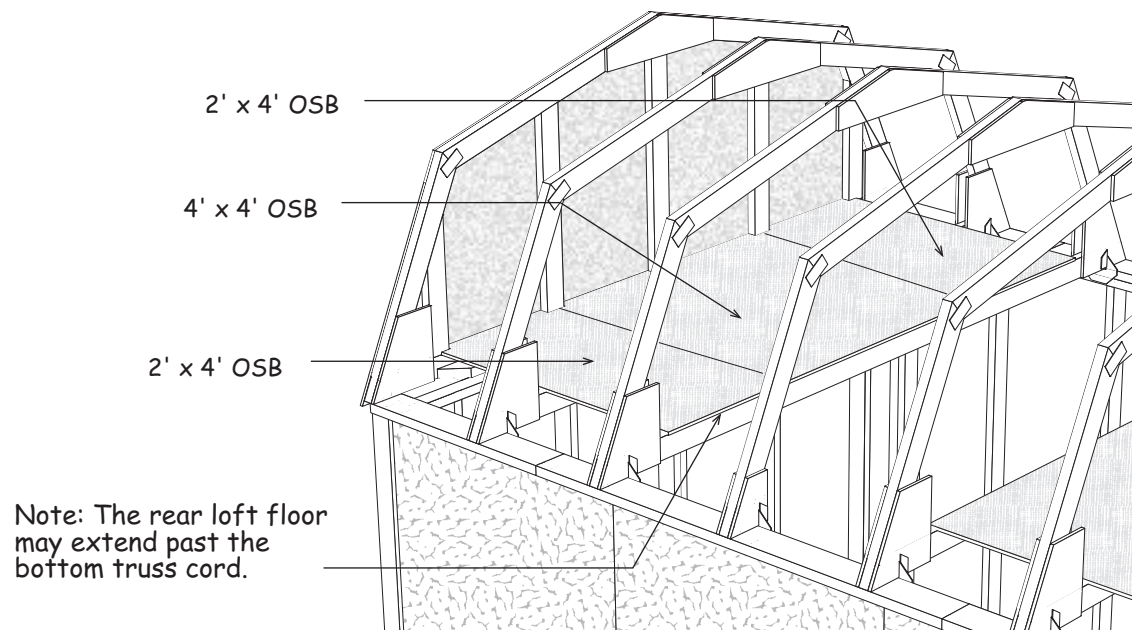

Step 14 Install Roof Sheathing

Install roof sheathing on the steep side of the roof. Use a straight edge to align the top of the sheathing with the top of the truss. See Detail 'B'. Make sure the trusses are plumb and the roof sheathing meets the center of the truss. Use 7d sinkers spaced 12" apart.

Install first sheet flush with back gable trim. Work back to front. The top roof sheathing will not extend to the ridge. This will allow an opening for air ventilation when you install a ridge vent.

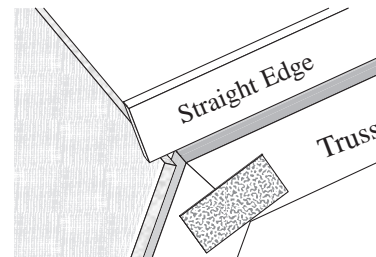
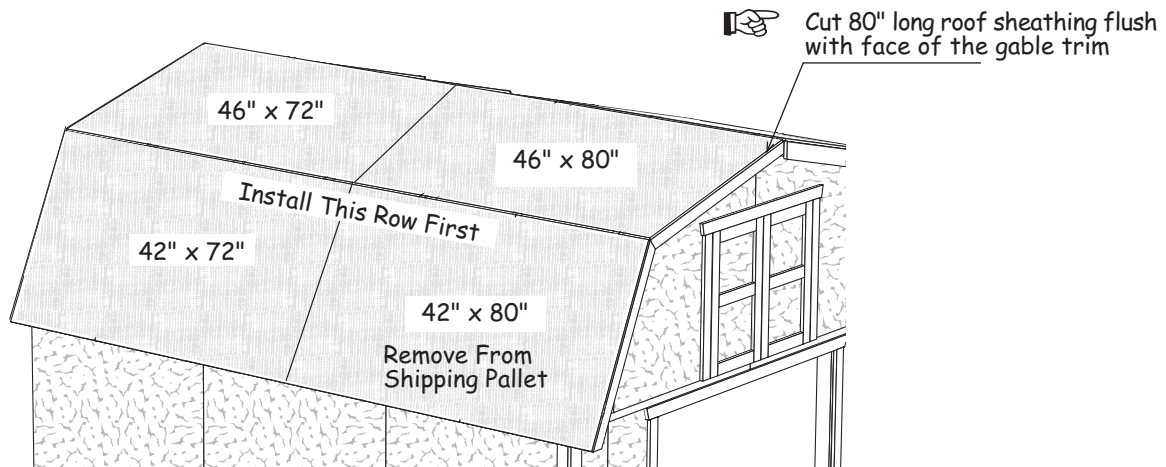

Detail 'B'

Install Shingles - not included in kit

1. Install felt paper and metal roof edge the perimeter of the building.
2. Install shingles according to the instructions on the wrapper. If you need more detailed instructions on installing shingles, there are good publications at book stores or newsstands.

Building Tip: Install ridge vent in lieu of shingles caps. Ridge vent provides ideal ventilation, preventing heat or moisture from damaging your building or its contents.

| Material Description | Building Length | |
|----------------------|-----------------|---------|
| | 10'x12' | 10'x16' |
| Roof Shingles | 7 bdl. | 10 bdl. |
| Roof 'drip' Edge | 6 pcs. | 7 pcs. |

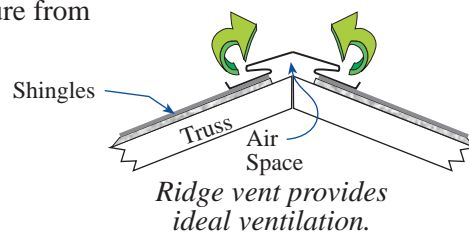

Step 15 Install Doors & Hardware

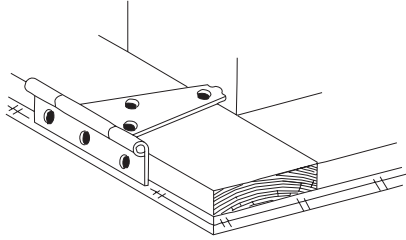

1. Lay the left door with the trim facing up. The siding on the left door extends past the door trim. See detail below.
2. Install 5" hinges to the left side of the door frame. To position the hinge properly, hold the rectangular plate against the frame. Use 1-3/4" black screws.
3. Install hinges to the right side of the other door.

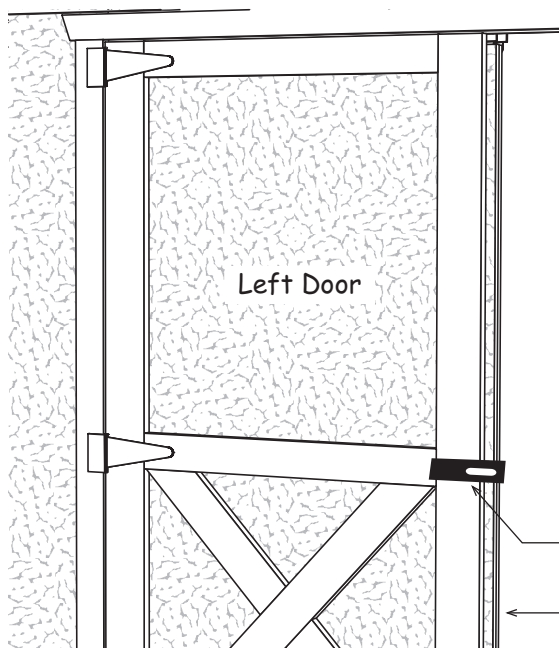

4. Before you fasten the hinges to the door trim, temporarily prop the doors in the opening. Leave a space at the top of the doors and between the doors and the side trim to allow room for the doors to expand when they absorb moisture.

If your door opening is out of square, the space around the doors will not be even. You can remove and reposition the side trim to make allowances for this. The side trim does not have to be flush with the frame of the door opening. You can move the trim in or out to make the door spacing equal.

5. Install hinges to trim with 2" screws.

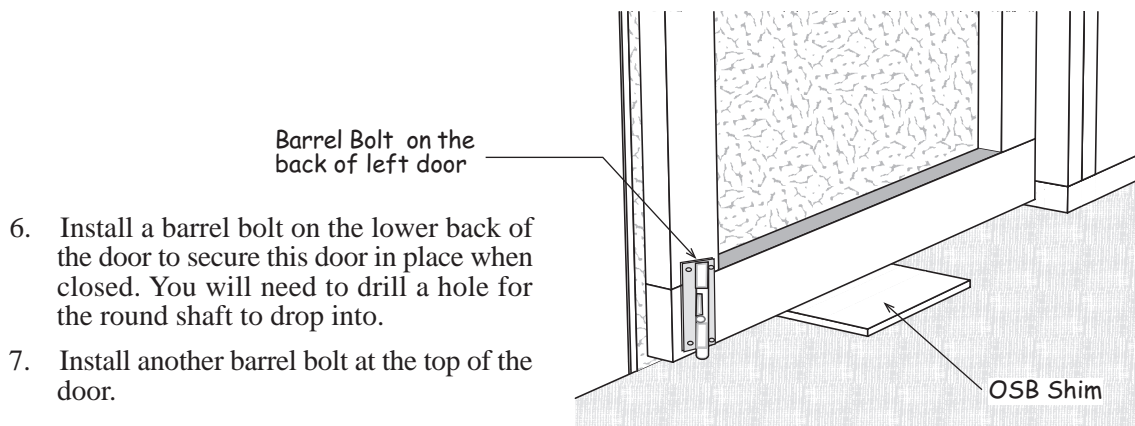

6. Install a barrel bolt on the lower back of the door to secure this door in place when closed. You will need to drill a hole for the round shaft to drop into.
7. Install another barrel bolt at the top of the door.

Meadowbrook and Woodville 10'x 12' Barn kit

| Qty. | 2x4 & 2x6 Framing | Size | | Qty. | Description | | Size |
|------|--|-----------|-----------|------|--|---------------|-----------------|
| 4 | Wall Plates | 120 | " | | White Pine Trim | | |
| 8 | Truss - Bottom Cords | 116 | 1/4" | 4 | 1x4 Gable Trim | 47 | 1/2" |
| 8 | 2x4 Boards Attached to Pallet | 80 | " | 4 | 1x4 Gable Trim | 43 | " |
| 31 | Wall Studs black ends | 72 | " | 4 | 1x4 Corner Trim | 75 | 3/4" |
| 4 | Wall Plates | 68 | 1/2" | 4 | 1x4 Corner Trim | 74 | 3/4" |
| 4 | Wall Plates | 65 | 1/2" | 2 | 1x4 Door Trim | 72 | " |
| 4 | Wall Plates | 56 | 1/2" | 1 | 1x3 Top Door Trim | 72 | " |
| 1 | Gable Studs & Framing | 36 | " | 4 | 1x3 Lower Wall Trim | 62 | " |
| 1 | Gable Studs & Framing | 35 | 3/4" | 2 | 1x3 Loft Door Trim | 29 | 1/4" |
| 4 | Gable Studs & Framing | 34 | 1/4" | 1 | 1x3 Loft Door Trim | 43 | " |
| 4 | Gable Studs & Framing | 21 | 1/2" | | Exterior Siding & Soffit | | |
| 9 | Truss Ridge Blocks | 22 | 3/4" | 3 | 48" x 77-1/4" | 2 | 12" x 77-1/4" |
| 6 | Gable Nailing Blocks | 15 | 3/4" | 2 | 36" x 77-1/4" | 4 | 48" x 75-3/4" |
| 4 | 2x6 Tie Plates for Sidewalls | 70 | 1/2" | 2 | 16" x 77-1/4" | 2 | 6" x 32-1/4" |
| | 2x3 Framing | | | 4 | Siding for Roof Gables | 48" x 48" | |
| 4 | Gable Overhangs | 47 | " | 4 | Siding for Roof Gables | 16" x 30" | |
| 4 | Gable Overhangs | 42 | 1/4" | 2 | Siding For Door Header | 6" x 32-3/4" | |
| 2 | Gable Blocks | 6 | 1/4" | 4 | 8" x 48" Front Soffit Panels (Woodville model) | | |
| | Pre-built Components | | | | Hardware | | |
| 14 | Pre-built Truss Halves | | | 3 | lb. 10d Sinkers | 20 | Truss Hangers |
| 2 | 32" x 72" Pre-built Barn Doors | | | 3 | lb. 8d Galv. | 75 | Hinge Screws |
| 2 | 18" x 29" Loft Door Frames | | | 2 | lb. 7d Sinkers | 1 | Door Hasp |
| 1 | 2x3 Door Header | 67-1/2" | | 3 | lb. 6d Common | 2 | 4" Barrel Bolts |
| | Loft Floor & Roof Sheathing | | | 1 | lb. 6d Galv. | 2 | 6" Barrel Bolts |
| 2 | 42" x 80" | 2 | 42" x 72" | 3 | lb. Hanger Nails | 12 | 2-1/2" Screws |
| 2 | 46" x 80" | 2 | 46" x 72" | 4 | 4" Door Hinges | 36 | 1" Screws |
| 2 | 48" x 48" | 4 | 24" x 48" | 6 | 5" Door Hinges | 24 | 1-5/8" Screws |
| | Miscellaneous Lumber | | | 22 | 1x4 Drive-on Plate | | |
| 12 | Wood Truss Ridge Gussets | 8" x 24" | | | Miscellaneous | | |
| 20 | Wood Bottom Truss Gussets | 12" x 12" | | 2 | Center Truss Blocks w/gusset | 3-1/2"x7-1/2" | |

Roof Material
by Owner

| | |
|------------------|--------|
| Roof Shingles | 7 bdl. |
| Roof 'drip' Edge | 6 pcs. |