



Owner's Manual
Pelican WF4/WF8 Premium Whole House
Iron and Manganese Filtration System

© Copyright 2019 Enviro Water Solutions Inc. All rights reserved.

All information contained herein is the property of Pelican Water Systems. Pelican Water Systems makes no warranty of any kind with regard to this material, including, but not limited to, the implied warranties of merchantability and fitness for a particular purpose. Pelican Water Systems shall not be liable for technical or editorial errors or omissions contained herein or for incidental or consequential damages in connection with the furnishing, performance, or use of this material. The information is provided "as is" without warranty of any kind and is subject to change without notice. This document contains proprietary information which is protected by copyright. No part of this document may be photocopied, reproduced, or translated into another language without the prior written consent of Pelican Water Systems. Pelican Water Systems is an Enviro Water Solutions, Inc. company.

Table of Contents

- Table of Contents 3**
- Product Operation and Specifications 4**
- Important Information 4**
- Complete Parts List 5**
- Installation Overview Diagram 7**
- Installation Overview 8**
- Pre-Installation 8**
 - Bypass Valve Installation 8
 - Bypass Valve Operations 8
 - Carbon Soak 10
 - Carbon Flush 11
- Installation 12**
 - Sediment Filter Assembly 12
 - Sediment Filter Installation 12
 - Chemical Injector Pump and Solution Tank Installation 13
 - Chemical Injector Pump Installation 14
 - Solution Tank Installation 14
 - Iron and Manganese Tank Installation 15
 - Whole House Water Filter Tank Installation 17
- Complete the Installation 18**
 - Setting the Electronic Head 19
 - Step 1: Setting the Date & Time 19
 - Step 2: Performing Manual Regeneration 19
 - Testing Chlorine Levels in Water - Dialing In 20
- Maintenance 21**
 - Sediment Filter 21
 - Replacing the Sediment Filter 21
 - Chemical Injector Pump 21
 - Solution Tank Refill 21
- Troubleshooting 22**
- Warranty 23**
 - Warranty Registration Form 25
- Product Certifications 26**

Product Operation and Specifications

Specification Description	WF4	WF8
Max Flow Rate	10 GPM	15 GPM
Minimum Working Pressure	25 PSI	
Maximum Working Pressure	80 PSI	
Maximum Vacuum	5 inch/127 mm Hg	
Operating Temperatures	36°F – 100°F	
pH Range	7 - 11	

Important Information

- Read these instructions carefully and determine the location of all system components before beginning installation.
- Check all applicable plumbing, building, and electrical codes for installation compliance.
- Install the system on the main water supply.
- The use of Teflon Tape and/or Pipe Thread Seal Paste will be needed on all threaded connections.
- Systems that contain electronic components cannot be installed outside in uncovered areas.

WARNING:

If this or any other system is installed in a metal (conductive) plumbing system, i.e. copper or galvanized metal, the plastic components of the system will interrupt the continuity of the plumbing system. As a result any errant electricity from improperly grounded appliances downstream or potential galvanic activity in the plumbing system can no longer ground through contiguous metal plumbing. Some homes may have been built in accordance with building codes, which actually encouraged the grounding of electrical appliances through the plumbing system. Consequently, the installation of a bypass consisting of the same material as the existing plumbing, or a grounded "jumper wire" bridging the equipment and re-establishing the contiguous conductive nature of the plumbing system must be installed prior to your systems use.









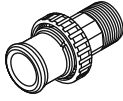
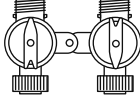

CAUTION:

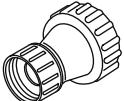
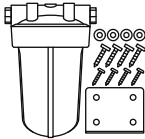
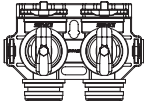
When adding a filtration/softening system to homes/buildings supplied by well water, the system should be installed following the pressure tank. **DO NOT USE this system for pneumatic or hydro pneumatic applications. If you are using a booster pump, then install this system following the booster pump.** If you have questions, please call customer service.

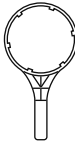
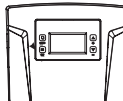
Complete Parts List

Note: Pelican supplies the parts below to accommodate a variety of water supply lines.

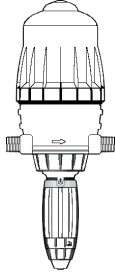
Table 1: Parts List

Part	Description	Qty.	Part	Description	Qty.
	1" Plastic Male NPT Assembly: V3007-04 1" Plastic Male NPT Assembly (2): O-Rings (2), Split Rings (2), and Connectors (2)	1		Bypass Valve: In/Out Bypass Valve with Red Arrow Handles	1
	1" PVC Tail Adaptor for Electronic Head Bypass 90 Degree 1" PVC Tail Adaptors also included	2		Hose Bib Assembly	1
	Sediment Filter System: Big Blue Filter Housing, Mounting Bracket, Phillips Head Screws (4), Bolt Head Screws (4), and Washers (4)	1		Bypass Valve for Electronic Head	1
	Sediment Filter: 5 Micron Poly-Spun Sediment Filter	1		Sediment Filter Wrench	1
	Electronic Head	1		Solution Tank	1
	PVC Tubing Drain Line (50 ft.)	1		Chemical Injector Pump Tubing	1
	Chlorine Test Strips	1		Chemical Injector Pump (2) 1" Bushings Included	1
	Non-Abrasive Auto Wax 4 oz. Bottle	1			

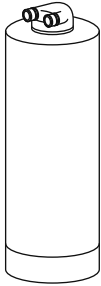
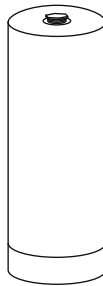
Part	Description	Qty.	Part	Description	Qty.
	Pelican Whole House Carbon Filter	1		Pelican Whole House Iron & Manganese Filter	1

Note: Drawings are not to scale.
Additional fittings will be needed to adapt to your plumbing.

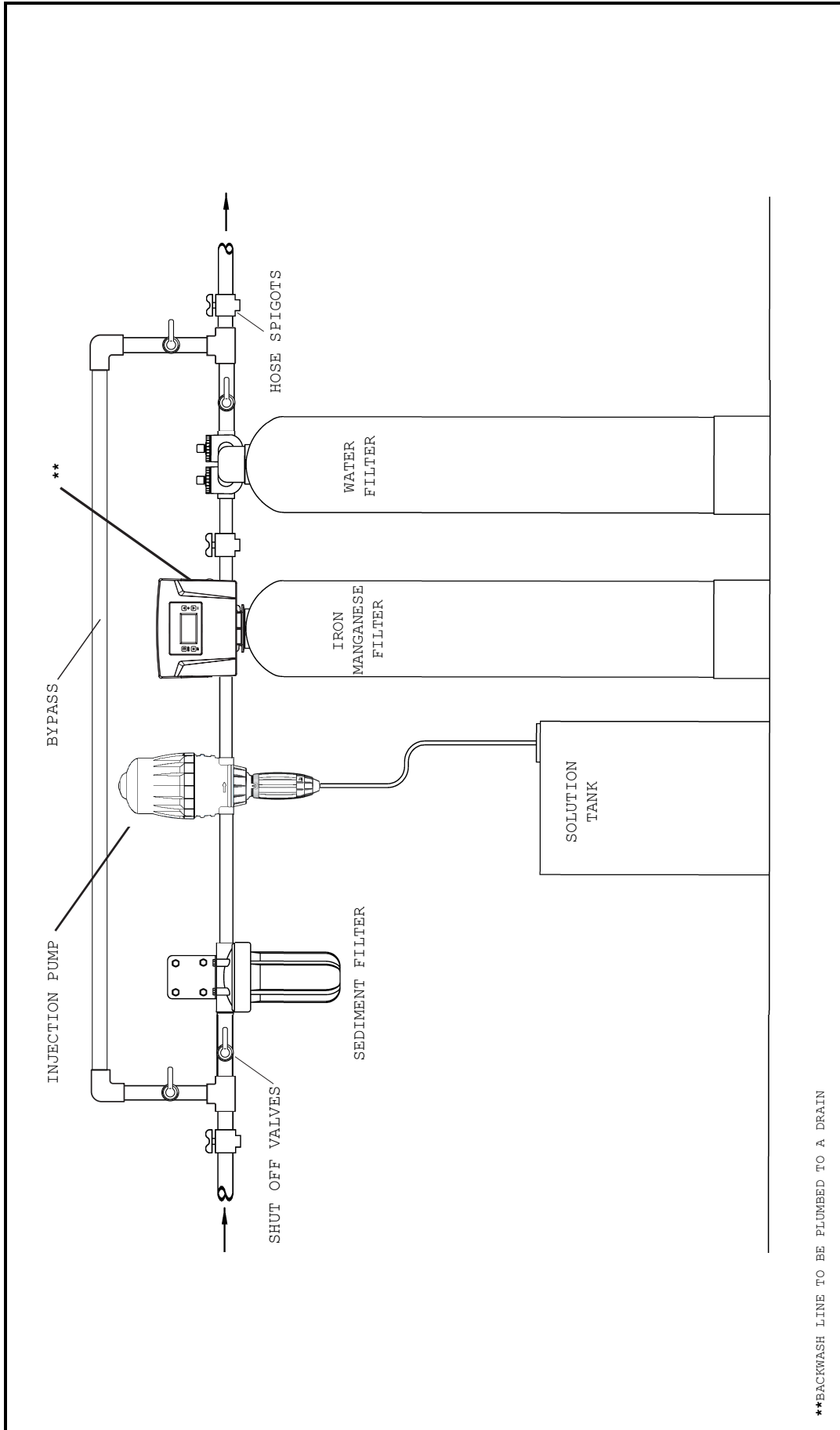

**BACKWASH LINE TO BE PLUMBED TO A DRAIN



3060 PERFORMANCE CR
SUITE 2
DELAND, FL 32724
1-877-842-1635
www.pelicanwater.com

DO NOT SCALE DRAWING
THIS DRAWING IS ISSUED IN CONFIDENCE AND CANNOT BE REPRODUCED OR USED TO MANUFACTURE ANYTHING SHOWN OR REFERRED TO WITHOUT DIRECT WRITTEN PERMISSION FROM PELICAN WATER SYSTEMS.

CONNECTION SIZE: 1"
MAX PRESSURE OPERATING: 80
PSI MAX TEMPERATURE: 100°

INSTALLATION OVERVIEW
WF 4/8

Installation Overview

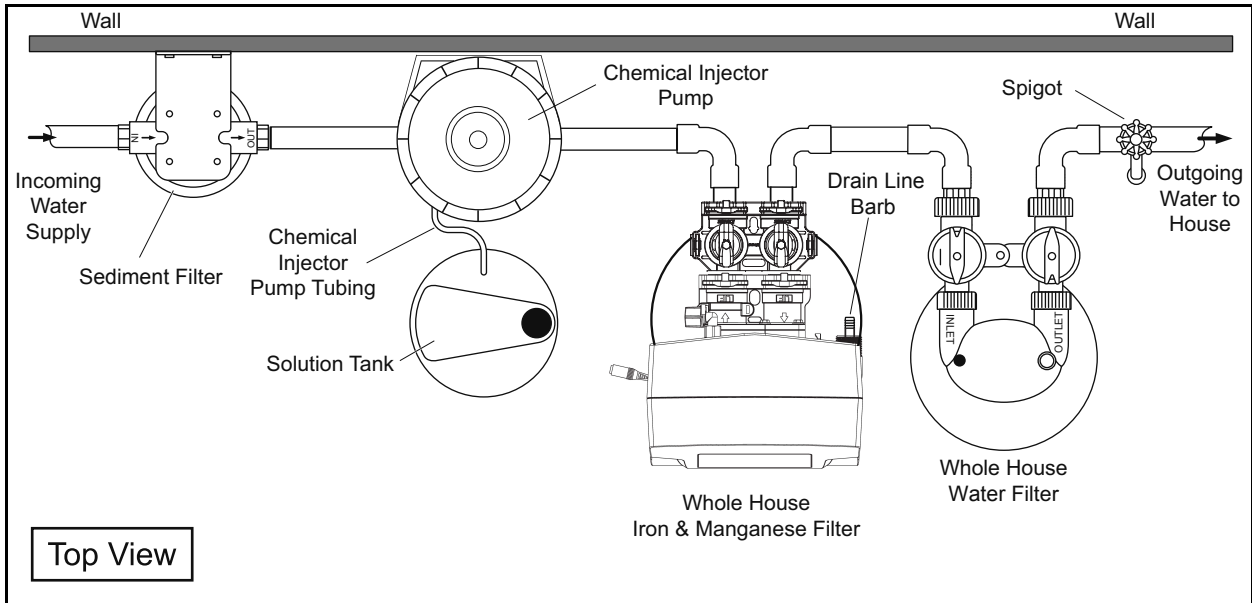

Figure 1

Pre-Installation

Bypass Valve Installation

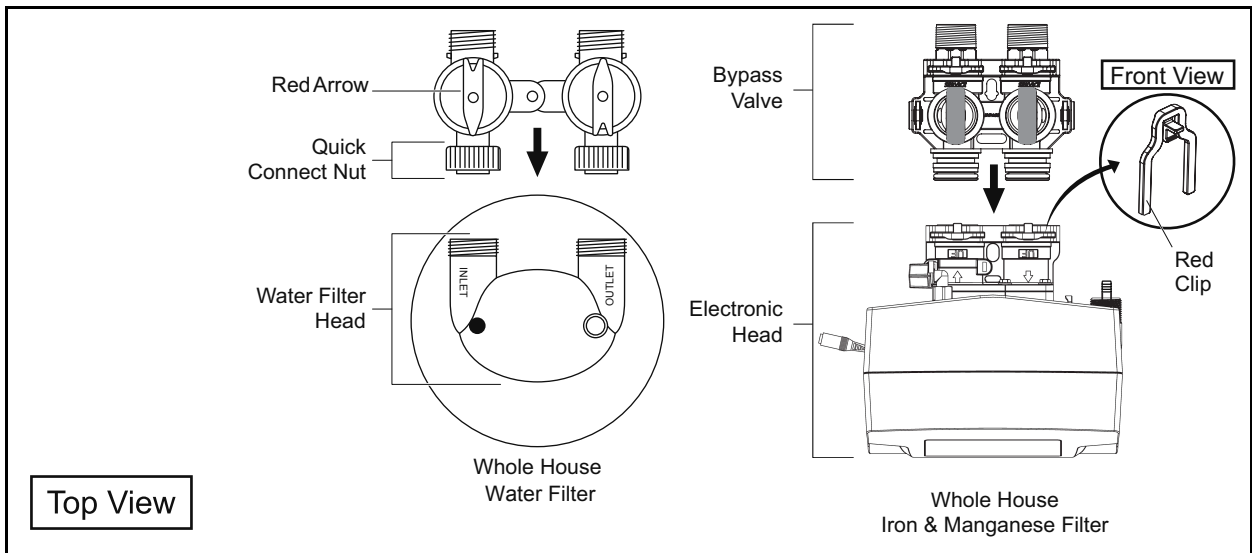
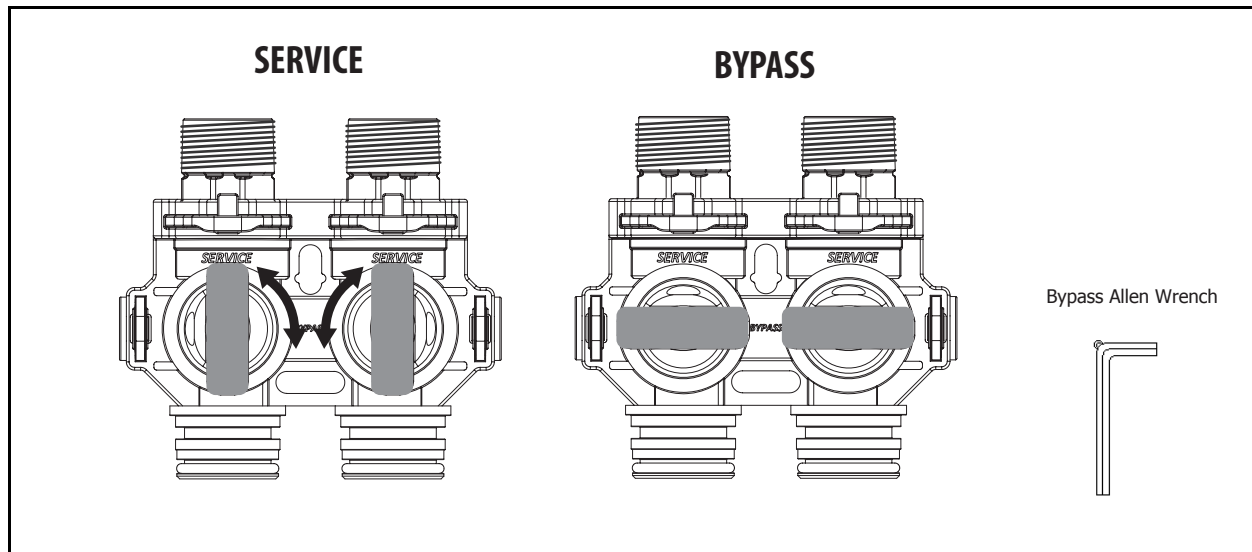

Figure 2

Whole House Water Filter - The Bypass Valve comes pre-assembled and ready to install with the O-Rings, Split Rings, and Quick Connect Nuts. Push the Bypass Valve into the head of the Whole House Water Filter with the unthreaded ends orientated towards the tank and hand-tighten the Quick Connect Nuts.

Whole House Iron & Manganese Filter - If the Red Clips are in the slots (female opening of Electronic Head) remove them. Push the male O-Ring side of the Bypass Valve into the female opening of the Electronic Head. Push the Red Clips back into the slots to tighten.

Bypass Operation



Notice:

The Bypass Valve on the Electronic Head can be set to Bypass or Service by turning the knobs on the top of the valve. The valves can be difficult to turn by hand until the seals become saturated. Use the supplied Bypass Allen Wrench to turn the knobs if necessary.

Note: The Red Arrows on the Whole House Carbon Filter Bypass may be pointing in a different direction than shown. If this is the case, remove the Red Arrows by pulling them straight up. Turn them around and reposition correctly onto the Bypass Valve so they are positioned as shown in the service position below.

The Bypass Valve on the Whole House Water Filter can be set to Bypass or Service by turning the Red Arrows on the top of the valve.

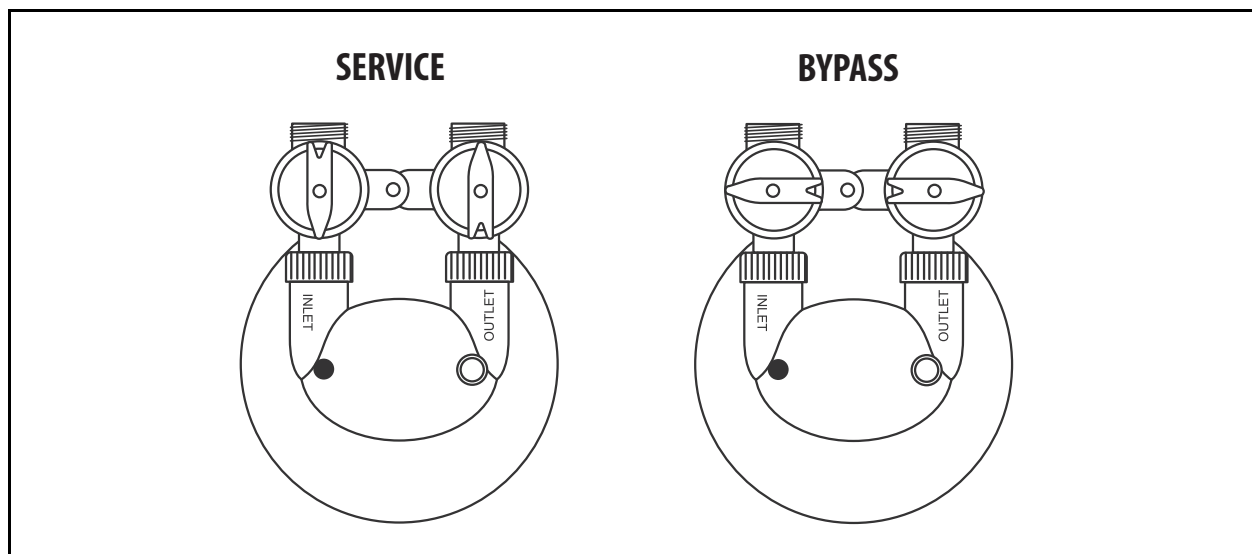

Water Filter - Carbon Soak

!IMPORTANT!

Your system will not be ready for use for a minimum of 48 hours while the Carbon Soak process takes place. Please plan your installation accordingly.



Notice:

Water will flow out of the outlet side of the Bypass Valve during this process. Be sure you perform this series of steps in a location suitable for water flow.

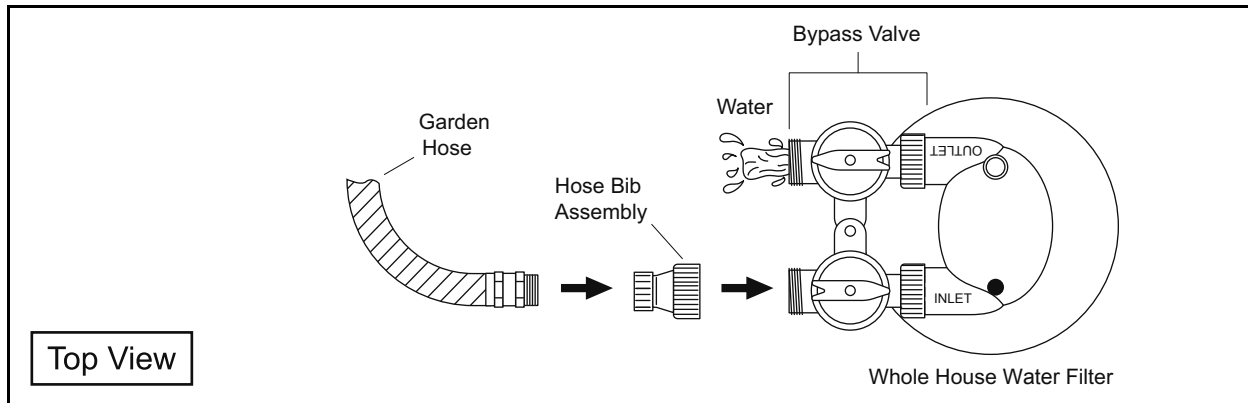

Figure 3

1. Attach a garden hose to the Hose Bib Assembly
2. Connect the Hose Bib Assembly to the inlet side of the Bypass Valve and hand tighten
3. Fill the Whole House Water Filter until water comes out of outlet side of the Bypass Valve.
4. Turn the water off.
5. Remove the garden hose from the Hose Bib Assembly. Do not remove the fitting.
6. Allow the carbon in the Water Filter to soak for a minimum of 48 hours prior to installation.

NOTE: Allowing the Whole House Water Filter to soak longer than 48 hours is completely fine as it will help with further saturation and minimize the break in period.

Water Filter - Carbon Flush

!IMPORTANT!

Do not perform the Carbon Flush until the Carbon Soak process is complete.



Notice:

Water will flow out of the outlet side of the Bypass Valve during this process. Be sure you perform this series of steps in a location suitable for water flow.

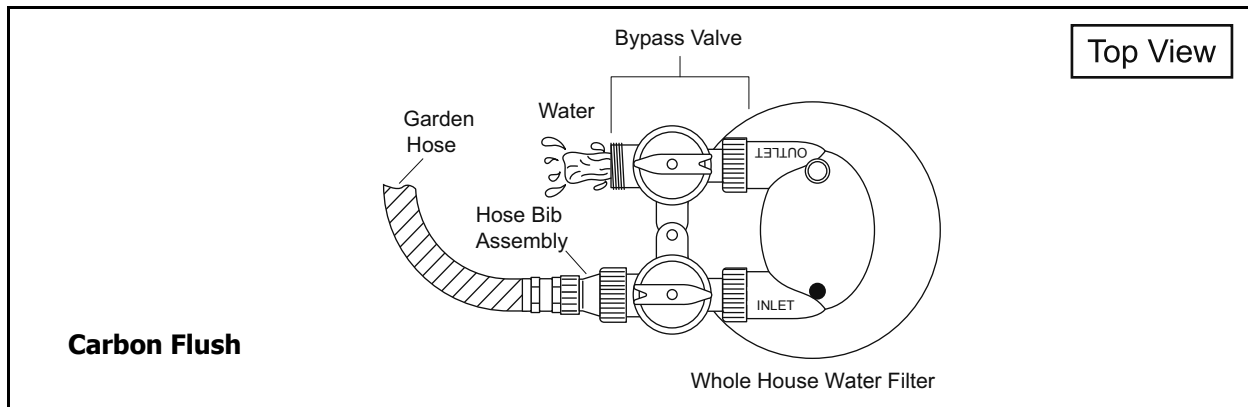

Figure 4

1. Reattach the garden hose to the Hose Bib Assembly.
2. Slowly turn on the water less than a 1/4 turn on the hose spigot.
3. Run water through the inlet side of the Bypass Valve for 30 minutes to expel any carbon fines.
4. Turn off the water.
5. Remove the Hose Bib Assembly from the inlet side and attach it to the outlet side of the Bypass Valve.
6. Slowly, fully open the hose spigot.
7. Run the water through the outlet side for 3 minutes to reset the carbon.
8. Turn off the water.
9. Remove the Hose Bib Assembly from the Bypass Valve and disconnect the garden hose.

Note: Please save the Hose Bib Assembly as this will be used in the future for the carbon replacement.

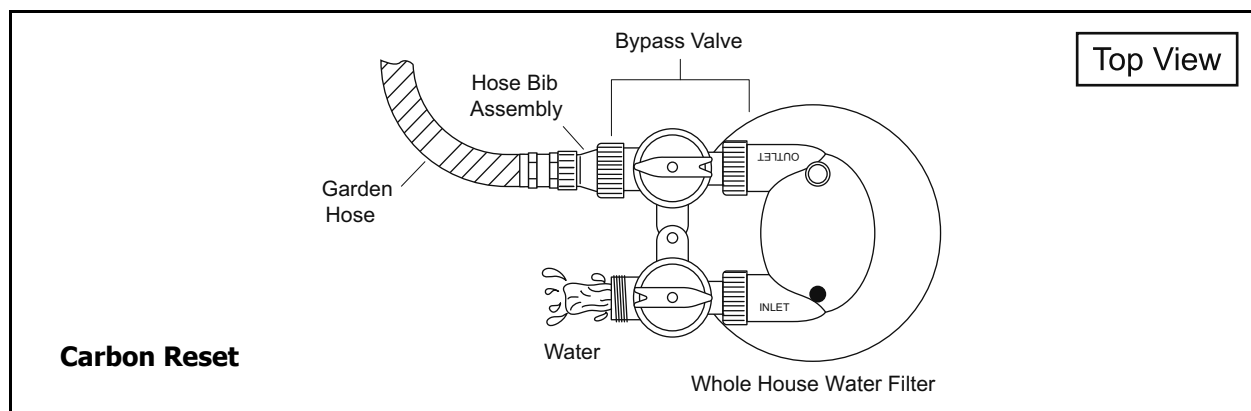

Figure 4-2

Installation

Sediment Filter Assembly

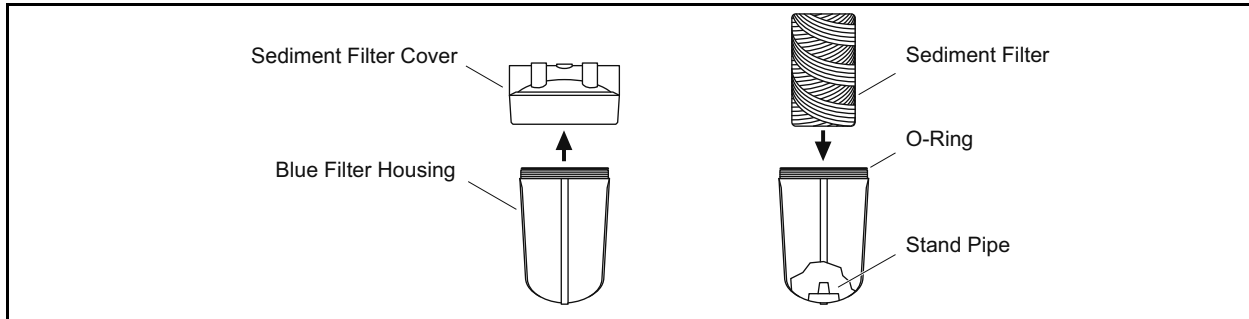

Figure 5

1. Unscrew the cover from the Blue Filter Housing.
2. Remove the plastic covering from the Sediment Filter.
3. Place the Sediment Filter onto the Stand Pipe in the Blue Filter Housing and set aside.

Sediment Filter Installation

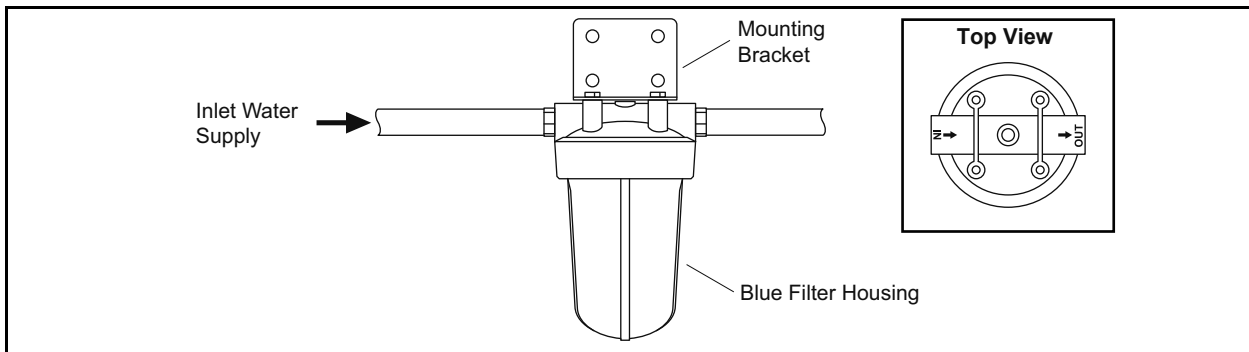

Figure 6

1. Shut off the water.
2. Attach the Filter Cover to the Mounting Bracket using the supplied Bolt Head Screws and Washers. Make sure to properly orientate the IN and OUT to match your flow pattern.
3. Attach the Mounting Bracket to the wall using the supplied Phillips Head Screws.
4. Hand tighten the Blue Filter Housing and then using the supplied Filter Wrench lightly snug the housing making sure not to over-tighten. (counter clockwise).
5. Determine the size of your inlet water supply line.



Notice:

The Sediment Filter Housing comes with a 1" threaded female inlet/outlet and will require additional fittings to adapt to your plumbing. A shut-off valve is recommended prior to the Sediment Filter System.

Chemical Injector Pump Overview

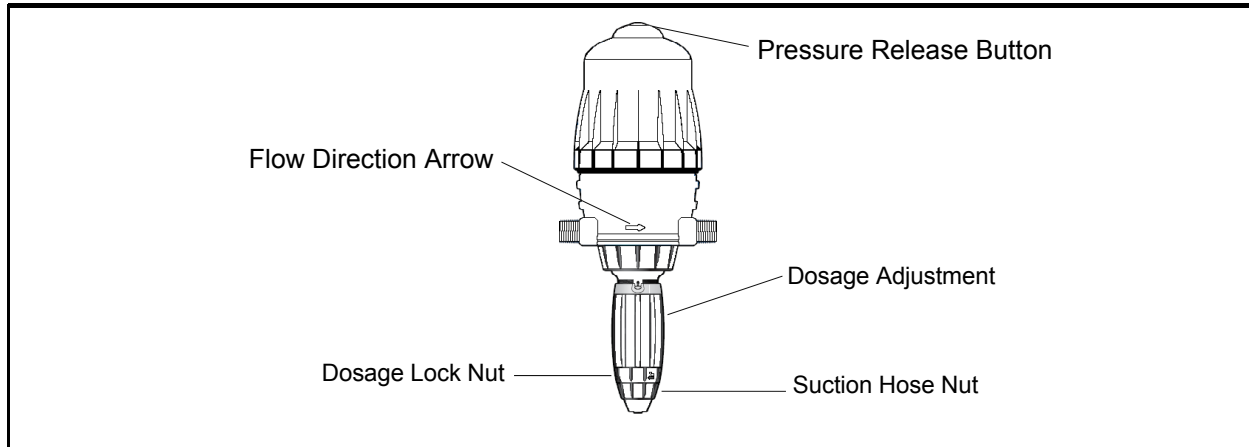

Figure 7

Pressure Release Button - Allows you to relieve the air pressure after install and maintenance.

Flow Direction Arrow - Indicates the proper flow pattern depending on how the unit is installed.

Dosage Adjustment - Allows you to increase or decrease the amount of solution injected per gallon of flow.

Dosage Lock Nut - Locks and unlocks the Dosage Adjustment for increasing and decreasing solution.

Suction Hose Nut - Compression nut the secures the injector tubing to the injector.

Chemical Injector Pump and Solution Tank Installation

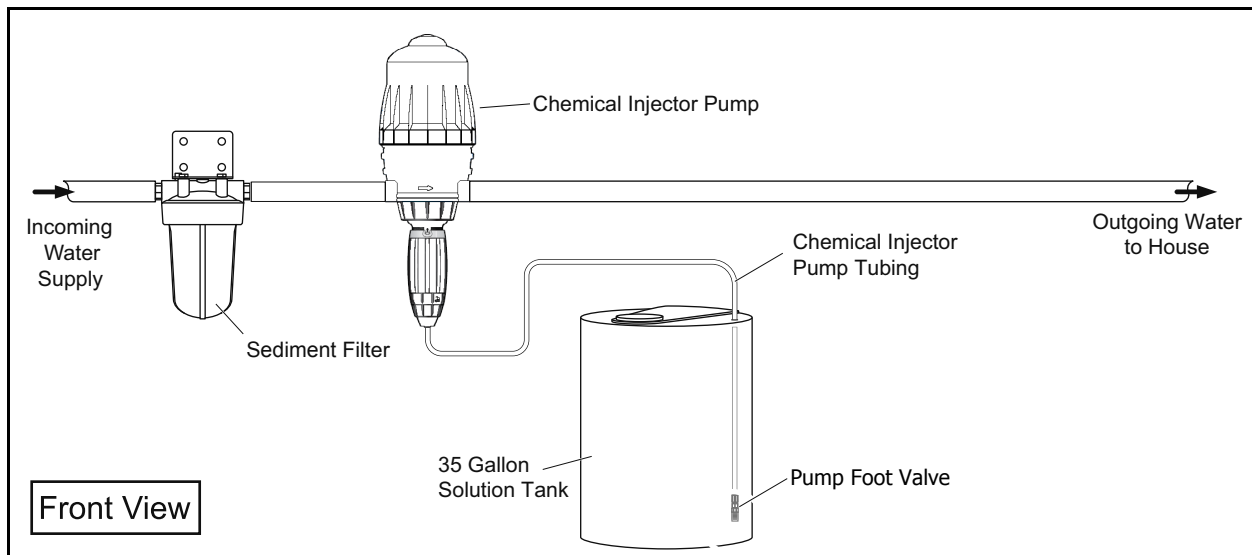

Figure 8

Chemical Injector Pump Installation

!IMPORTANT!

Install the Chemical Injector Pump onto the water supply after the Sediment Filter and before any other filtration or softening system.

1. Determine the size and material of your incoming water supply line from the Sediment Filter System.
2. Mount the Chemical Injector Pump to the wall using the provided bracket. Line up the inflow and outflow connections with the current water line.
3. Remove the two red thread protectors from inlets and discard. Injector Pump has 3/4" connections, two 1" bushings are included.
4. Plumb the Injector Pump into your water line. The arrow on the body of the Injector Pump shows the correct water flow direction. The Injector Pump can be rotated to match your flow direction. The water should enter and exit the pump following the direction of the arrow.

Solution Tank Installation

1. Remove the black cap from the opening on the Solution Tank.
2. Drill one 1/2" hole into the top of the Solution Tank. (Hole should be larger than tubing to allow air in)
3. Insert the end of the Chemical Injector Pump Tubing with the pump foot valve connected, into the hole which was covered by the black cap on the top of the Solution Tank.
4. Feed and pull the other end of the tubing through the drilled opening on the top of the Solution Tank.
5. Determine the length of Chemical Injector Pump Tubing required for the foot valve to reach 4" from the bottom of the Solution Tank and cut tubing.
6. Connect the Chemical Injector Pump Tubing to the suction valve on the Chemical Injector Pump by removing the suction hose nut, place nut over tubing, push tubing onto suction valve and tighten nut.
7. Fill the Solution Tank with 17 gallons of bottled water and proper number cups of bleach based on the % concentration of Sodium Hypochlorite noted on the bottle. (see chart below)

Concentration of Bleach (% Sodium Hypochlorite)	Number of Cups	Gallons of Water
3.00%	12	17
5.25%	7	17
6.00%	6	17
8.25%	4.5	17

!IMPORTANT! Ensure the Chemical Injector Pump Tubing is free of kinks and the Solution Tank is not sitting directly on concrete. The cold temperatures held by concrete floors can separate your solution.

Iron and Manganese Tank Installation

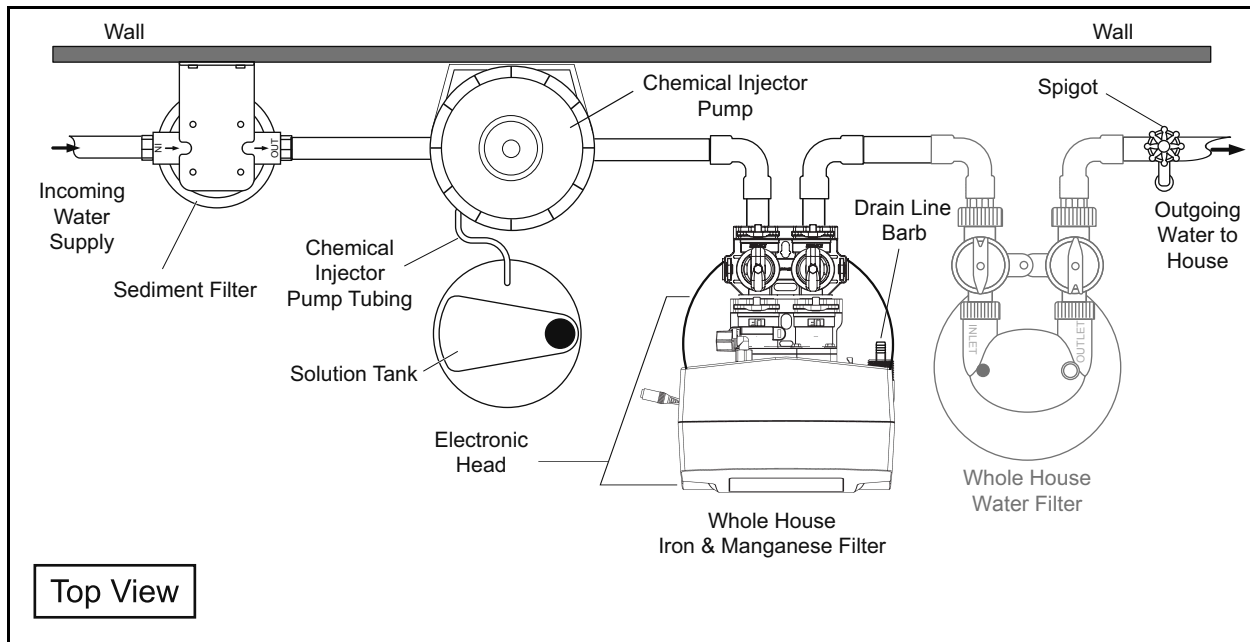

Figure 8

1. Level the Whole House Iron & Manganese Filter.



Notice:

If the tank is not level, lift the tank straight up 6 inches and tap it on the ground until the tank stands vertical. The bottom of the tank is round and the boot allows the tank to stand upright.

2. Determine the size and material of your incoming water supply line from the Injection Pump and choose the appropriate fittings required to connect it to the Bypass Valve.



CAUTION:

Do not over-tighten any of the fittings during installation.

Table 2: Bypass Valve Fittings

Part	Description	Qty.
	1" PVC Tail Adaptor for Electronic Head Bypass	2

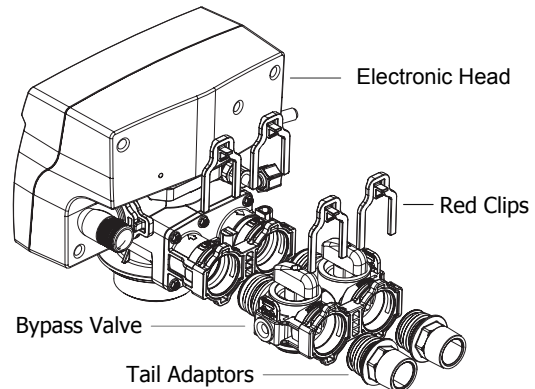

3. Remove the gray cap from the top of the Whole House Iron & Manganese tank.
4. Screw the Electronic Head onto the tank hand-tight.
5. Install the fittings onto the inlet and outlet, following the labels on the Head.
6. Connect the incoming water supply to the fitting on the inlet side of the Bypass Valve.
7. Connect the outgoing water supply to the outlet side of the Bypass Valve.
8. Firmly press one end of the PVC Tubing Drain Line onto the Drain Line Barb, and secure the other end of the line to a drain.

IMPORTANT!

- Ensure the PVC Tubing Backwash Drain Line is not submerged and is free of kinks.
- Maximum vertical rise of the backwash line is 6 feet.
- If incorporating two or more backwashing systems make sure to keep the drain lines separate.

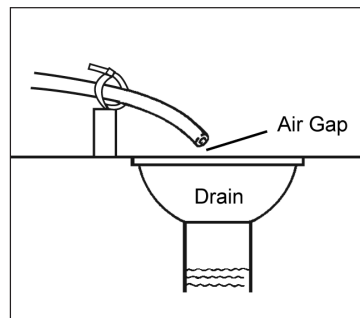

Whole House **Water** Filter Installation

1. Level the Whole House Water Filter.



Notice:

If the tank is not level, lift the tank straight up 6 inches and tap it on the ground until the tank stands vertical. The bottom of the tank is round and the boot allows the tank to stand upright.

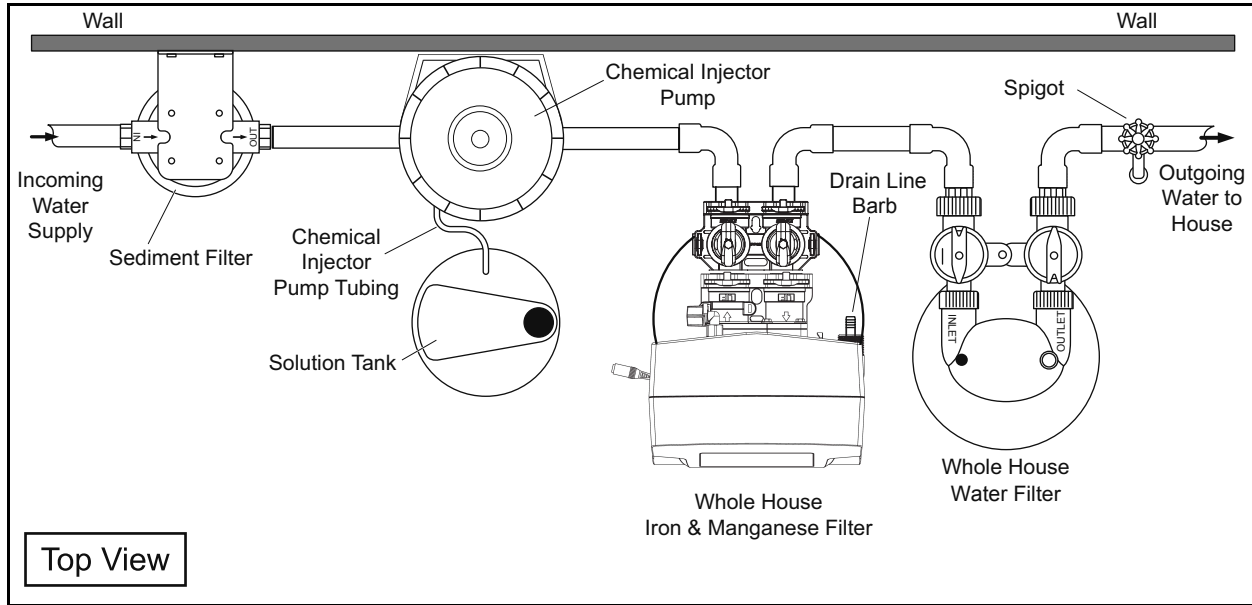

Figure 9

2. Determine the size and material of your incoming water supply line from the Whole House Iron & Manganese Filter and choose the appropriate plumbing required to adapt to the 1" Male NPT Assembly.

CAUTION:

Do not over-tighten any of the fittings during installation.

Table 3: Bypass Valve Fittings

Note: The fitting below is designed with a 1/4" give to allow for proper pipe alignment. It will not leak and is intended to have some flexibility.

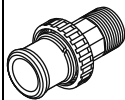
Part	Description	Qty.
	1" Plastic Male NPT Assembly: V3007-04 WS1 Fitting 1" Plastic Male NPT Assembly (2): O-Rings (2), Split Rings (2), and Connectors (2)	1 bag

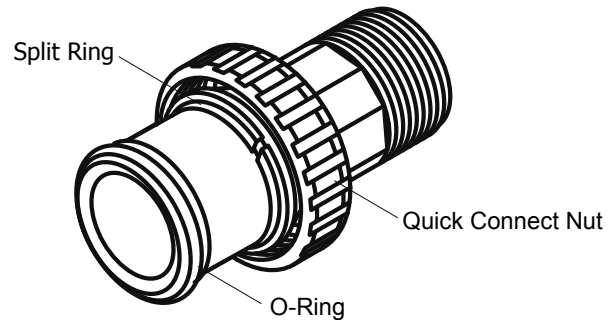

3. Install the fitting onto the inlet and outlet sides of the Bypass Valve. Follow the diagram supplied with the fitting.
4. Connect the incoming water supply from the Whole House Iron & Manganese Filter to the fitting on the inlet side of the Bypass Valve.
5. Connect the outgoing water supply back into the home to the outlet side of the Bypass Valve.

⚠ CAUTION:

Avoid high flow rates such as bathtub, utility sinks, hose bibs, multi-headed showers, body sprayers, or anything that is considered high flow for the first 72 hours to avoid flow restrictions caused by carbon blockage of the top basket inside the carbon tank.

Carbon dust may be released into the water lines of the house/building during the first few days of water use after Whole House Water Filter installation. The carbon dust is harmless, but may give the water a gray appearance that should diminish within a week or 10 days depending on water use.

Complete the Installation

1. Turn on the main water supply.
2. Press Pressure Release Button on top of Injector Pump.
3. Check for leaks.
4. Peel off the protective plastic wrap from the stainless steel tank jackets.
5. Add the Pelican logo sticker in the desired location on the tank.

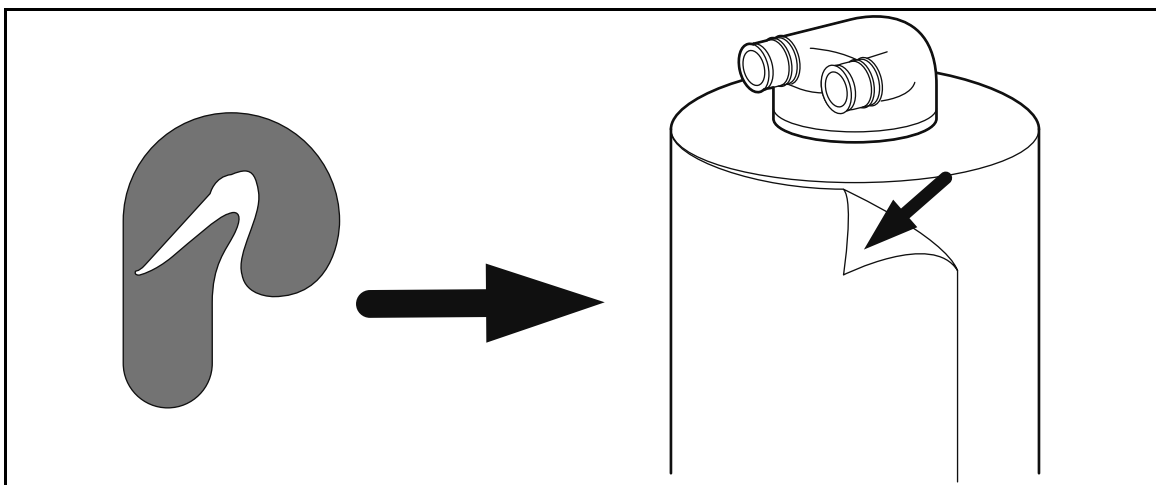

6. Wax stainless steel tank jacket(s) with wax provided or any other non-abrasive auto wax a minimum of 1-2 times per year or as needed based on the installed environment.

Programming the Electronic Head

Note: Power Source - For safety reasons the outlet must be protected by a Ground Fault Circuit Interrupter (GFCI).

Your system is pre-set to regenerate every 3 days at 2:00 am, the complete process takes 20 minutes

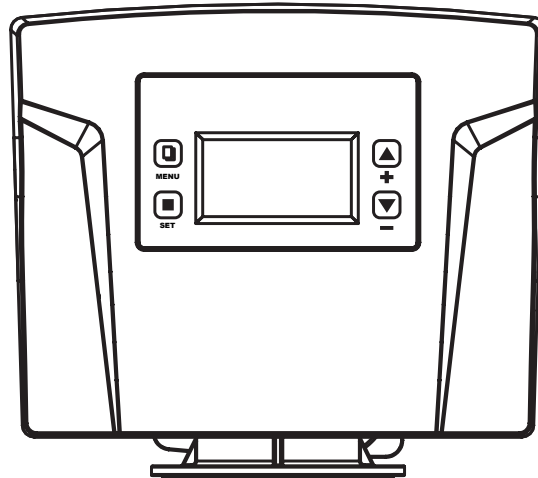

Step 1: Setting the Date & Time

1. Press and hold the MENU button until you hear the beep to unlock.
2. Press MENU button for menu.
3. Press SET once **Date & Time Setting** is highlighted.
4. Using the UP and DOWN buttons input the correct Date and Time pressing SET after each input.
5. Once set press the MENU button to return to the main menu.

IMPORTANT!

You will need to manually regenerate (**Regen Now**) your system prior to use. To do so follow the programming below. You will not be able to use water for 20 minutes during this process.



Notice:

In the event of spikes in Iron and Manganese levels you may choose to manually regenerate your system if you experience colored water from your system.

Step 2: Performing a Manual Regeneration

1. Using the DOWN button select **Manual Regen** and press SET.
2. Using the UP or DOWN button select either **Regen Now** or **Regen Tonight**.
 - Regen Now** will start a regeneration process immediately.
 - Regen Tonight** will regenerate the system at the default regeneration time of 2:00am.
3. Once selected press the SET button to confirm. Gears will make noise and water will start to flow. Allow the system to regenerate for approximately 20 minutes.
4. Once complete press the MENU button to return to the main menu.
5. Your programming is now complete.

Testing Chlorine Levels in Water - Dialing In

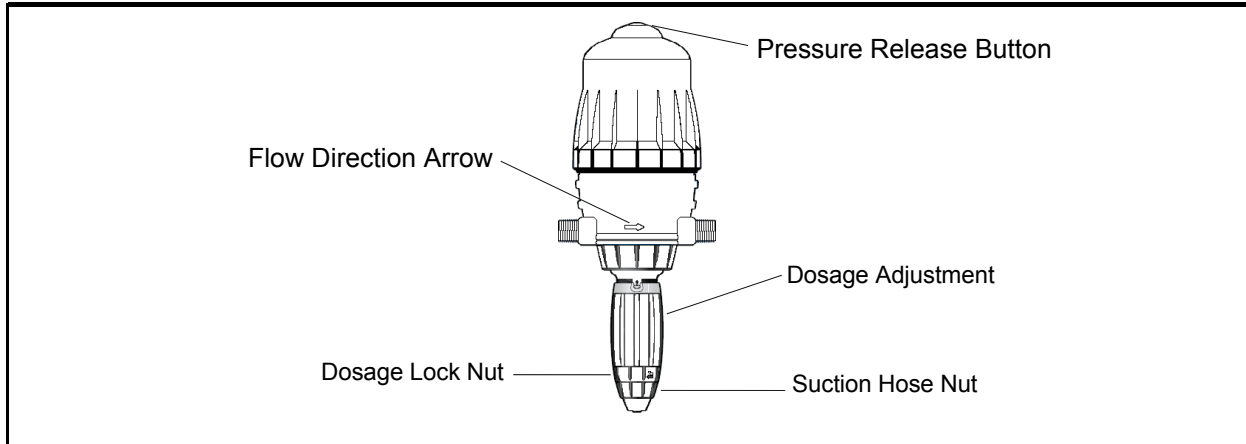

Figure 13

1. Put the Whole House Water Filter into bypass. (See page 9 for bypass position)
2. Turn on the nearest cold water faucet to the system.
3. Listen and watch the pump to make sure it is pumping. The pump should pulse and not run continuously. If the water is off, the pump will stop.
4. Let the water run for 15 minutes.
5. After 15 minutes, use a chlorine test strip to test a sample of water from the cold water faucet.
 - a. The optimum chlorine level reading is 2.6ppm on the test strip.
 - b. If you do not have a reading of chlorine you will need to add 3 more cups of bleach to the solution tank and mix. Note the new total or bleach to 17 gallons water. Repeat steps 4 & 5 to achieve a new sample for testing. Double check to make sure the Water Filter is in bypass. Page 9 shows the bypass position.
 - c. If your reading is close to 2.6ppm then you will unlock the dosage adjustment on the injector pump and rotate up two full turns. Re-lock the dosage adjustment and repeat steps 4 & 5 to achieve a new sample for testing.
6. If you needed to test another sample and you still do not have a reading of chlorine add another 3 cups of bleach and mix. Note the new total of bleach to 17 gallons of water. Repeat steps 4 & 5 to achieve a new sample for testing.
7. If your reading is close to 2.6ppm then you will unlock the dosage adjustment on the injector pump and rotate up two full turns. Re-lock the dosage adjustment and repeat steps 4 & 5 to achieve a new sample for testing.

!IMPORTANT!

If after testing again there is still no reading of chlorine we recommend calling in to speak with a Technical Support representative. 877-842-1635

Concentration of Bleach (% Sodium Hypochlorite)	Number of Cups	Gallons of Bottled Water
3.00%	12	17
5.25%	7	17
6.00%	6	17
8.25%	4.5	17

Maintenance

Sediment Filter

It is recommended that the Sediment Filter be replaced every 6-9 months depending on the amount of sediment present in the water supply. If the system has been working properly and the pressure is slowing, it may be time to change the Sediment Filter. Check the Sediment Filter and replace if necessary.

Replacing the Sediment Filter

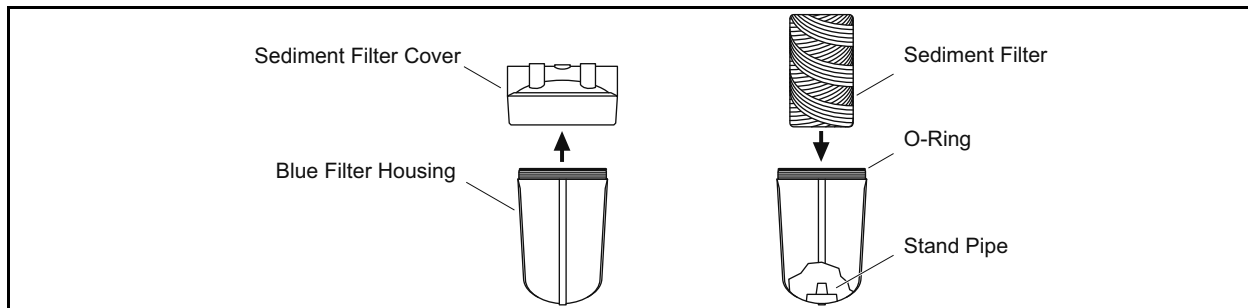

1. Turn off the main water supply to the Sediment Filter System and bypass all tanks.
2. Run a faucet (cold water) inside the house to relieve the pressure. (Leave faucet open)
3. Unscrew the Blue Filter Housing clockwise using the supplied Filter Wrench.
4. Remove the existing Sediment Filter and discard.
5. Remove the O-Ring and wipe the groove clean. Lubricate a new O-Ring with a coating of clean silicone grease. Replace O-Ring and press the O-Ring down into the groove with two fingers.

Note: This step is important to ensure the proper filter seal. Make sure the O-Ring is seated level in the groove. If the O-Ring appears damaged, stretched, or crimped it should be replaced.

6. Place a new Sediment Filter onto the Stand Pipe in the Blue Filter Housing.
7. Screw the Blue Filter Housing onto the Filter Cover hand tight. Lightly snug the housing with the spanner wrench making sure not to over-tighten.
8. Turn on main water supply slowly to allow the Sediment Filter System to fill with water and expel air from lines. Put tanks back in service, out of bypass.
9. Check for leaks.

Chemical Injector Pump:

1. Change every 6-12 months (Injector Pump Seal Kit - 3 O-Rings & Check Valve)

Note: Spare kits for replacement purposes can be obtained by calling your customer service representative at Pelican Water.

Solution Tank Refill — **Bleach & Water**

1. Check the level of the Solution Tank twice per month. Do not let the liquid in the tank fall below $\frac{1}{4}$ full.
2. Fill the Solution Tank with bleach and treated water as needed. (Water that has gone through your filtration system).

Troubleshooting

Problem	Solution
Water leaking at the top of the tank around the head.	You may need to turn the head to tighten it. The tank head is pre-installed hand-tight, do not overtighten the head (just turn it snug).
The tank leans to one side or is not level.	If the tank is not level, lift the tank straight up 6 inches and tap it on the ground until the tank stands vertical. The bottom of the tank is round and the boot allows the tank to stand upright.
Water pressure is slowing.	It is recommended that the Sediment Filter be replaced every 6-9 months depending on the amount of sediment present in the water supply. If the system has been working properly and the pressure is slowing, it may be time to change the Sediment Filter. Check the Sediment Filter and replace if necessary.
Water appears grey or cloudy.	Water may appear grey or cloudy for the first seven to ten days after installation due to extra carbon dust.
Water pressure is slowing immediately after installation.	High flow rates such as bathtubs, utility sinks, hose bibs, multi-headed showers, body sprayers, or anything that is considered high flow for the first 72 hours should be avoided. If you suspect a carbon blockage of the top basket due to a high-flow situation within the first 72 hours of installation, turn off any running water for at least 30 minutes. This will clear the blockage and you can resume using water at low or normal flow rates.
Water is backfilling into the solution tank	The check valve on the lower end of the pump is stuck in the open position. Turn water off, relieve pressure, remove the suction hose nut as well as the retaining nut underneath. Remove the check valve by pulling down. Rotate the white retainer cap to expose the check valve. Clean o-ring, inner housing and Replace.

Warranty

Pelicans Limited Lifetime Warranty

Pelican Water ("Pelican") warrants to the end user ("customer") that its tanks (13" and smaller), valves, in/out non-electric heads, bypass's, fittings and housings for POE systems ("Covered Items") will be free from defects in material and workmanship under normal use and service for a limited lifetime of twelve (12) years from the date of original purchase**.

Pelican 7 Year Limited Warranty

Pelican Water ("Pelican") warrants to the end user ("customer") that its solid-state electronic heads ("Covered Items") from April 1st, 2017 on, will be free from defects in material and workmanship under normal use and service for a period of 7 years from the date of original purchase.

Limitations and Responsibilities

Pelican's obligation to the customer under these warranties shall be limited, at Pelican's option, to replacement or repair of Covered Items by these warranties, labor is not covered. These warranties do not cover replacement filter cartridges, elements or lamps. Prior to return or repair of Covered Items, the customer must obtain a return goods authorization number from Pelican by/at and at Pelicans option, return the Covered Items freight prepaid. Any Covered Item repaired or replaced under these warranties will be returned prepaid standard freight to the original point of shipment. Expedited freight options are available at customer expense.

No warranty is made, and is explicitly excluded, with respect to defects or damages due to neglect, misuse, alterations, accident, misapplication, physical damage, or damaged caused by fire, acts of God, or freezing. These warranties apply only to the original registered owner so long as the owner owns/lives in the home in which the unit was originally installed. Customer must register their system with Pelican within 90 days of purchase* in order to obtain a warranty. Warranty will discontinue after the unit is removed from the location where it was originally installed. Warranty begins on the date of delivery of product to the customer. Improper maintenance of system (ie not replacing filters or media, for example) on time will be considered "neglect" and explicitly excluded from the warranty. Installation of any system on water conditions outside of or beyond the recommended specs of any system voids any warranty.

Pelican gives this warranty to the original owner/customer in lieu of all other warranties, express or implied, including without limitation any implied warranties of merchantability or fitness for a particular purpose or treatment of certain water and hereby expressly disclaims all other such warranties. THE WARRANTIES PELICAN GIVES IN THE ABOVE PARAGRAPHS ARE EXCLUSIVE, PELICAN DISCLAIMS ALL OTHER WARRANTIES, EXPRESS, IMPLIED OR STATUTORY AND SPECIFICALLY DISCLAIMS ANY IMPLIED WARRANTIES OF MERCHANTABILITY, FITNESS FOR A PARTICULAR PURPOSE OR IMPLIED WARRANTY OF WORKMANLIKE PERFORMANCE. Pelican's liability hereunder shall not exceed the cost of the product. Under no circumstances will Pelican be liable for any incidental or consequential damages or for any other loss, damage or expense of any kind, including loss of use, arising in connection with the installation or use or inability to use the Covered Items or any water treatment system the Covered Items are incorporated into. These warranties are governed by the laws of the state of Florida and may change at any time without notice..

*Failure by California and Quebec residents to complete the product registration form does not diminish their warranty rights.

**For all orders placed on or after June 3rd, 2011.

Warranty Registration Form

Send in this Warranty Registration Form to validate your warranty or visit www.PelicanWater.com to complete warranty registration form online.

Pelican Warranty Registration Form

Date Item(s) were Received:	Order ID#:	Model:
_____	_____	_____
Dealer Purchased From:		

Model/Serial Number:		

Name:	_____	
Address:	_____	
City:	State:	Zip:
_____	_____	_____

Send To:

Pelican Water Systems
3060 Performance Circle, Suite 2
DeLand, FL 32724
Phone: 1-(877) 842-1635

Plumber's Information (optional)

We like to recommend good plumbers throughout the USA and if you were happy with your installer please give us their information so we can pass it on as a courtesy. Thank you for your time.



Name of Plumbing Company used to install system: _____

Phone #: (_____) - _____ of the Plumbing installer

!IMPORTANT!

Do not use where water is microbiologically unsafe or with water of unknown quality without proper disinfection before or after the filter/softener system.

Product Certifications

	<p>Pelican NaturSoft-NS3/NS6 – WQA Gold Seal tested and certified under NSF/ANSI61 for material safety and tested according to NSF/ANSI 42 for structural integrity only</p>
	<p>Clack V3007-xx Bypass Fittings – WWQA Gold Seal Certified to NSF/ANSI Standard 44 for material safety and structural integrity only</p>