

EASTPORT 3LT VANITY LIGHT



Specifications

Material Construction:	Formed Steel
Lens:	Frosted white glass
Lens Dimensions:	7" H x 4" Dia (each)
Lamp Type & Wattage:	Three 60W, medium base incandescent lamps
Mounting:	Wall mounted
Finish:	Satin Nickel (US15)
Voltage:	120V
Weight:	3.96 LBS
Companion Fixtures:	Wall mounts, vanity lights, pendants, ceiling mounts



Dimensions

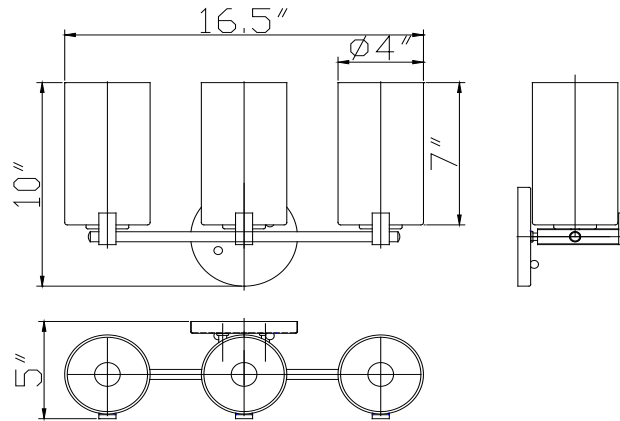

Warranty & Compliances

Warranty	10 Year Limited Warranty
UL	UL/cUL; Suitable for dry locations
ADA	N/A
EnergyStar	N/A



Companion Fixtures

Eastport 3LT Vanity Light SN	573147	
Eastport 3LT Foyer Pendant SN	500983	
Eastport 1LT Mini Pendant SN	577510	
Eastport 2LT Wall Mount SN	577528	
Eastport 4LT Vanity Light SN	577536	
Eastport 4LT Vanity Light SN	577536	
Eastport 4LT Large Ceiling Mount SN	577544	
Eastport 1LT Wall Mount SN	573154	
Eastport 2LT 13" Ceiling Mount SN	570937	
Eastport 2LT Bath Bar Light SN	570929	
Eastport 3LT Dining Room Pendant SN	573139	
Eastport 3LT Pendant Stem SN	570911	

Type: Job: Order Code: Approvals:
--

Design House reserves the right to make changes in materials, specifications & models at any time. Design House also reserves the right to discontinue product without notice or obligation.