

Obtaining a permit for your Best Barns or Sentry Buildings kit.

Building code offices and HOA's may require different documents to obtain a permit. The homeowners first step is to contact their local code office and ask what is needed for the size of building to be purchased.

Typically, the necessary documentation may include some or all of the following.

- Elevations showing at least two sides of structure.
- Site plan showing existing structures and proposed build site.
- Engineered drawings for truss system indicating snow and wind load ratings.*
- Cross sections of wall framing and foundation.
- Tie down locations for high wind load areas.

Permit requirements vary based on location. Some areas may not require a permit at all. The documents provided by Best Barns or Sentry Buildings are intended to help the homeowner with the permit process but do not guarantee a permit will be issued.** It is the homeowner's responsibility to determine if a permit is required and submit the necessary documentation if so.

* Engineered truss drawings stamped for your individual state can be obtained upon request. A deposit will be required if shed or garage kit has not yet been purchased. Contact us directly at 800-245-1577 for further details.

** Certain states such as Florida and California have stringent requirements for obtaining a permit. Depending on your location, a civil engineer's services may be required to provide necessary documents. These services are the homeowners responsibility to obtain and are not included in the purchase of a shed or garage kit.



Before you order our kit or begin construction, obtain a building permit. If additional documents are required contact questions@barnkits.com.

Belmont Elevation

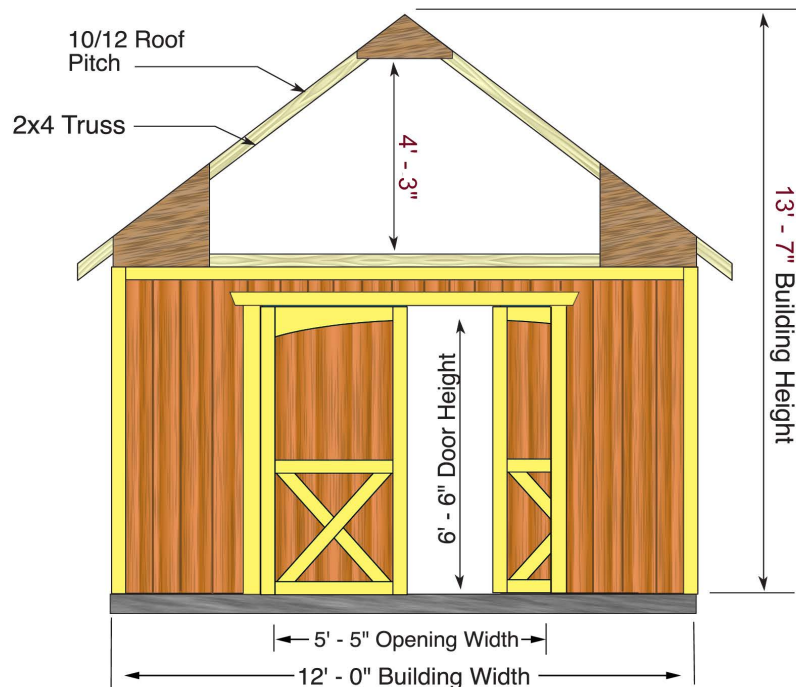
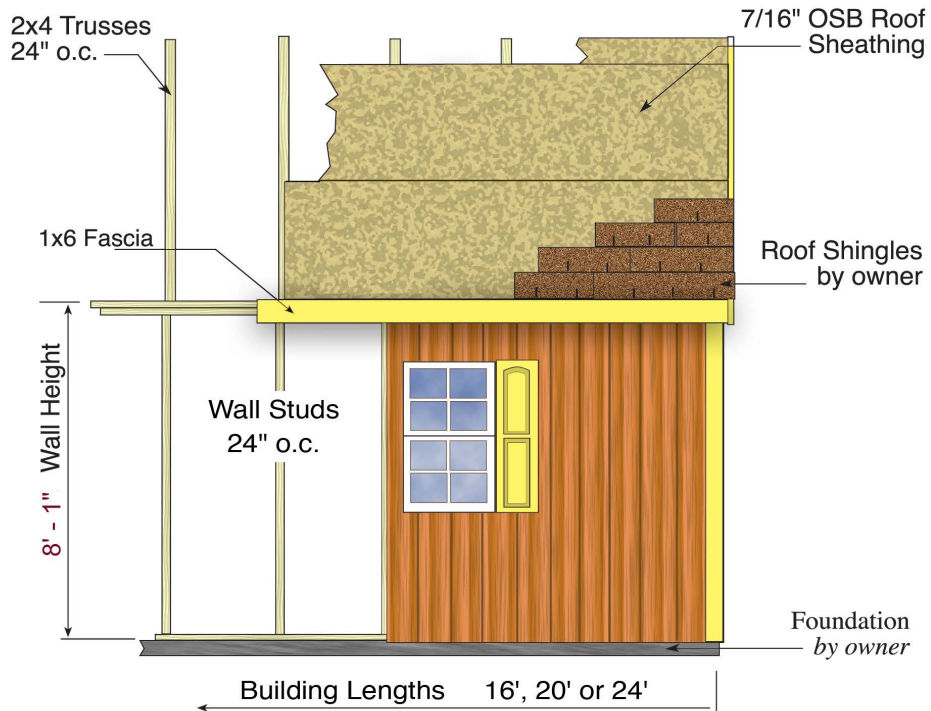

Job	Truss	Truss Type	Qty	Ply	Job Reference (optional)
PER19972	T1	KINGPOST	1	1	

8.210 s Feb 23 2018 MiTek Industries, Inc. Tue May 7 20:12:18 2019 Page 1
 ID:w_Vrt2CSXIP0IKOwCij40wysCGn-IRRfio2CqBsmtQ_fdU9HLPrVoAqkTzTalqTKENzIneB

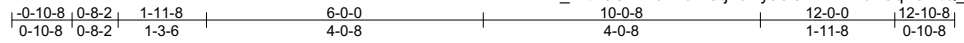

Attach 7/16" APA OSB Gussets To Both Sides
 (2) Rows 0.131" x 2" Nails at
 3" c/c Into All Members As Shown

Scale = 1:33.6

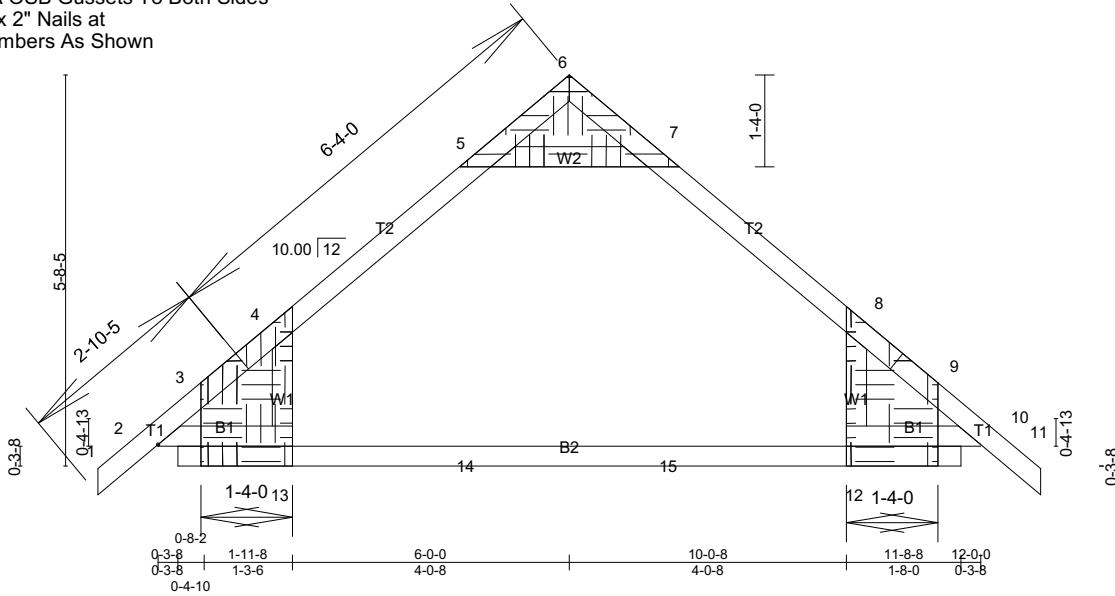

Plate Offsets (X,Y) - [2:0-3-2,0-3-3], [6:0-2-0,Edge], [10:0-3-2,0-3-3], [12:0-6-8,0-1-8], [13:0-6-8,0-1-8]

LOADING (psf)		SPACING-	2-0-0	CSI.	DEFL.	in (loc)	l/defl	L/d	PLATES	GRIP	
TCLL (roof)	20.0	Plate Grip DOL	1.15	TC	0.75	Vert(LL)	-0.21 12-13	>676	240	MT20	197/144
Snow (Pf/Pg)	42.0/60.0	Lumber DOL	1.15	BC	0.65	Vert(TL)	-0.37 12-13	>393	180		
TCDL	10.0	Rep Stress Incr	YES	WB	0.12	Horz(TL)	0.03 10	n/a	n/a		
BCLL	0.0 *	Code	FRC2014/TPI2007	Matrix-P							
BCDL	5.0									Weight: 57 lb	FT = 20%

LUMBER-
 TOP CHORD 2x4 SP No.2
 BOT CHORD 2x4 SP No.2
 WEBS 2x4 SP No.3 *Except*
 W2: 2x4 SPF No.2

BRACING-
 TOP CHORD Structural wood sheathing directly applied or 5-7-6 oc purlins.
 BOT CHORD Rigid ceiling directly applied or 10-0-0 oc bracing.

MiTek recommends that Stabilizers and required cross bracing be installed during truss erection, in accordance with Stabilizer Installation guide.

REACTIONS. (lb/size) 10=775/Mechanical, 2=775/Mechanical
 Max Horz 2=-206(LC 10)
 Max Uplift 10=-305(LC 12), 2=-305(LC 12)
 Max Grav 10=879(LC 17), 2=879(LC 16)

FORCES. (lb) - Max. Comp./Max. Ten. - All forces 250 (lb) or less except when shown.
 TOP CHORD 2-3=-887/213, 3-4=-772/211, 4-5=-641/274, 7-8=-641/274, 8-9=-783/211, 9-10=-900/213
 BOT CHORD 2-13=-23/537, 13-14=-25/535, 14-15=-25/535, 12-15=-25/535, 10-12=-24/545
 WEBS 5-7=-639/450, 4-13=-69/297, 8-12=-69/297

- NOTES-**
- Unbalanced roof live loads have been considered for this design.
 - Wind: ASCE 7-10; Vult=150mph (3-second gust) Vasd=116mph; TCDL=6.0psf; BCDL=3.0psf; h=15ft; B=18ft; L=12ft; eave=4ft; Cat. II; Exp C; Encl., GCpi=0.18; MWFRS (directional); Lumber DOL=1.60 plate grip DOL=1.60
 - Roof design load is based on 60.0 psf ground snow load; normal terrain, exposure factor 0.7; and normal structure, importance factor 1.0.
 - Unbalanced snow loads have been considered for this design.
 - This truss has been designed for a 10.0 psf bottom chord live load nonconcurrent with any other live loads.
 - * This truss has been designed for a live load of 20.0psf on the bottom chord in all areas where a rectangle 3-6-0 tall by 2-0-0 wide will fit between the bottom chord and any other members, with BCDL = 5.0psf.
 - Refer to girder(s) for truss to truss connections.
 - Provide mechanical connection (by others) of truss to bearing plate capable of withstanding 305 lb uplift at joint 10 and 305 lb uplift at joint 2.

LOAD CASE(S) Standard



Best Barns model: _____
 ___ ft. wide x ___ ft. long

Manufactured by:
 Reynolds Building Systems, Inc.
 205 Arlington Drive
 Greenville, PA 16125
 phone: 800-245-1577
 fax: 724-646-0772

Common Foundation Cross Sections

This document illustrates common foundation types which can be used for construction of Best Barns 12 ft. wide structures. Alteration may be necessary to conform to homeowners intended use and or permitting requirements.

Drawings not to scale.

Instructions:

Check appropriate foundation cross section and provide specifications as necessary.

Homeowner may also design and draw in space provided for custom foundation type.

Concrete Slab

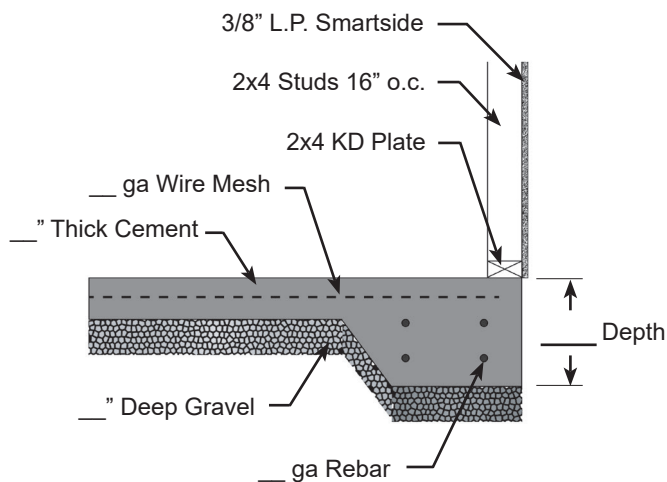

Wood Floor

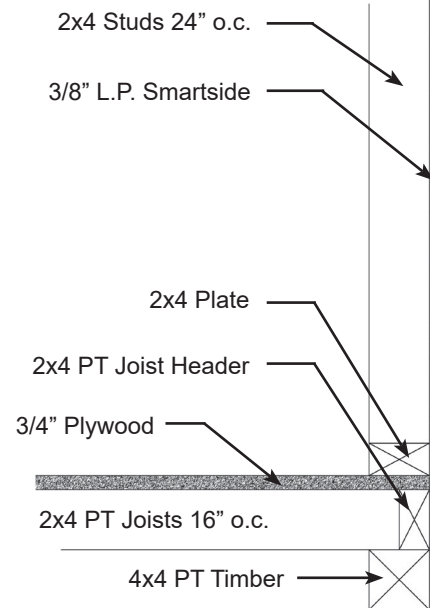

Homeowner Design

Best Barns model:

- Arlington
- Belmont
- Geneva
- Glenwood
- Springfield

12ft. wide x ___ft. long

Manufactured by:
Reynolds Building Systems, Inc.
205 Arlington Drive
Greenville, PA 16125
phone: 800-245-1577
fax: 724-646-0772

**Truss & Wall
Cross Section**

Top of wall inclusive of wall framing, loft floor and truss cross sections.

Drawing not to scale.

Instructions:

Homeowner may provide additional information as appropriate.

Notes:

Refer to installation manual for further detail.

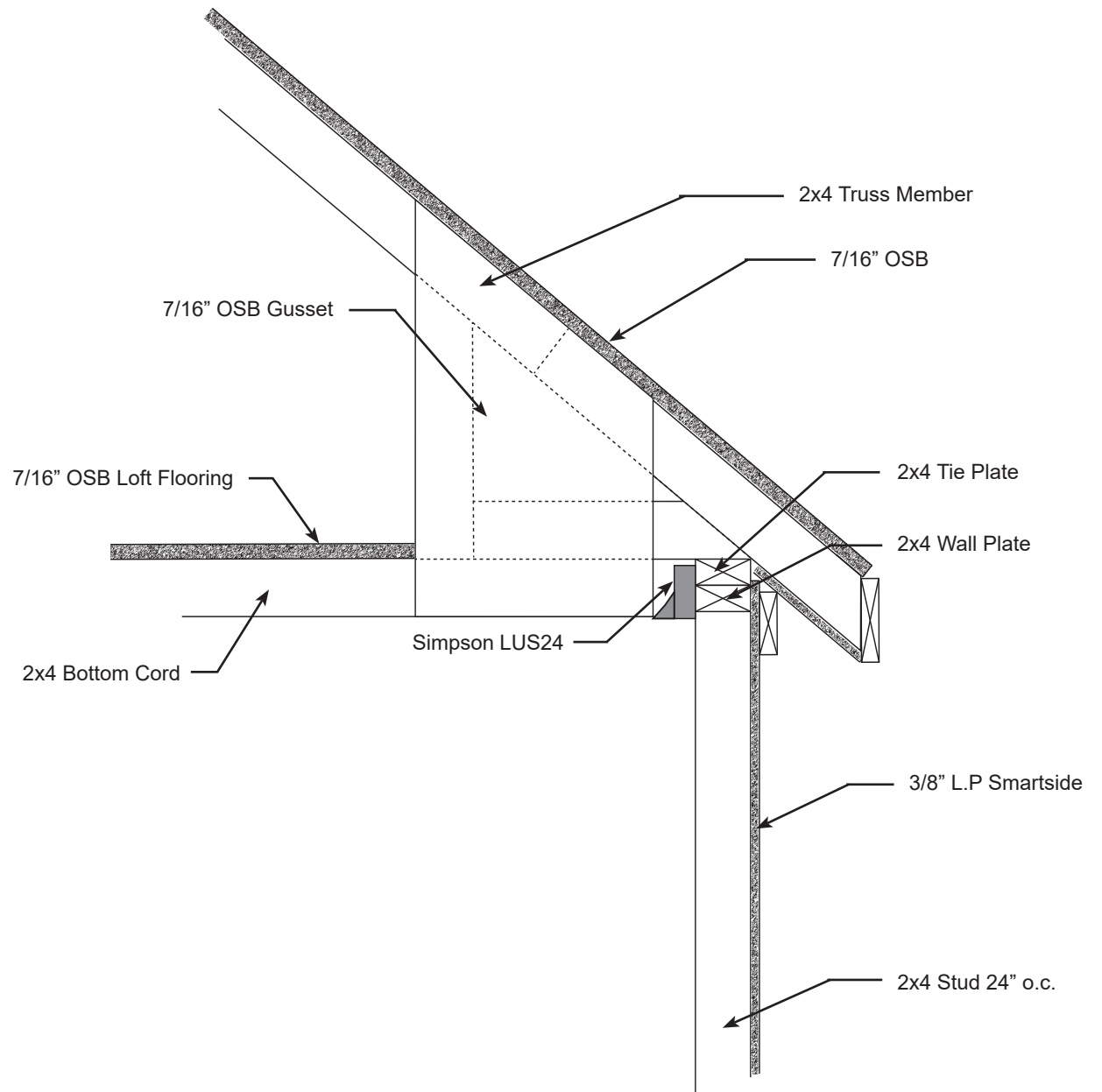

Site Plan for:

Manufactured by:
Reynolds Building Systems, Inc.
205 Arlington Drive
Greenville, PA 16125
phone: 800-245-1577
fax: 724-646-0772

Instructions:

Draw property line, existing structures and proposed placement of building.

Homeowner may also be required to show trees and shrubs. Check with HOA or permit office for requirements.

A large, empty rectangular box with a black border, intended for the site plan drawing. It occupies the right two-thirds of the page.