

Item# 7673 - How To Assemble Your Counter High Chair

TOOLS NEEDED: Philips screwdriver, power drill optional

CAUTION: When assembling chair, **DO NOT** completely tighten the bolts and nuts until all the parts & holes are properly aligned.

(REV. 03/2017)

PARTS INCLUDED:

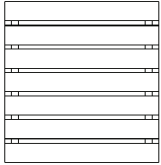

(A) Seat

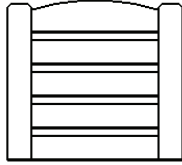

(B) Backrest

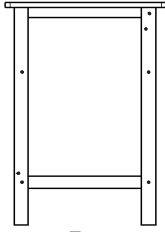

L

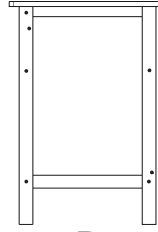

R

(C) Legs



(D1)
Bottom
Crossband

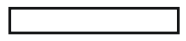

(D2)
Bottom
Crossband

4 PC
Nuts



4 PC
Iron
Washer

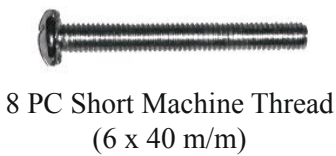

8 PC Short Machine Thread
(6 x 40 m/m)

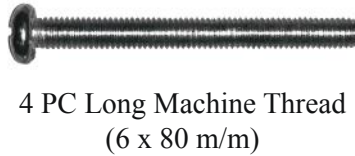

4 PC Long Machine Thread
(6 x 80 m/m)



Spanner
(4 x 4 m/m)



13#
Spanner

Step 1:

Attach (C) Legs with (D1) & (D2) Bottom Crossbands using 2 Short Machine Threads (6 x 40m/m) for each side.

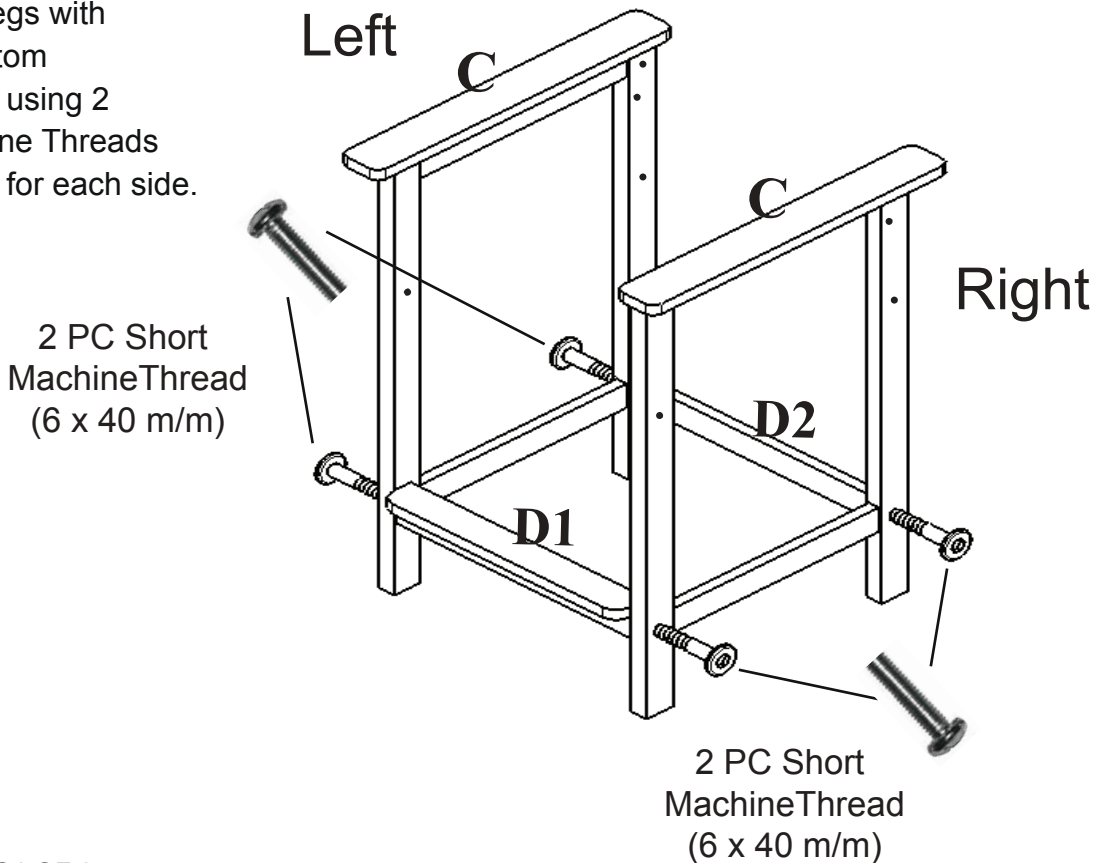

2 PC Long Machine Thread (6 x 80 m/m),
2 Nuts & 2 Iron Washer

Step 2:

Place **(A)** Seat in the middle and screw **(C)** Legs with two Long Machine Threads (6 x 80m/m), two Nuts & two Iron Washers for each side.

*Make sure to place Nuts & Iron Washer on the inside of **(C)** Legs.

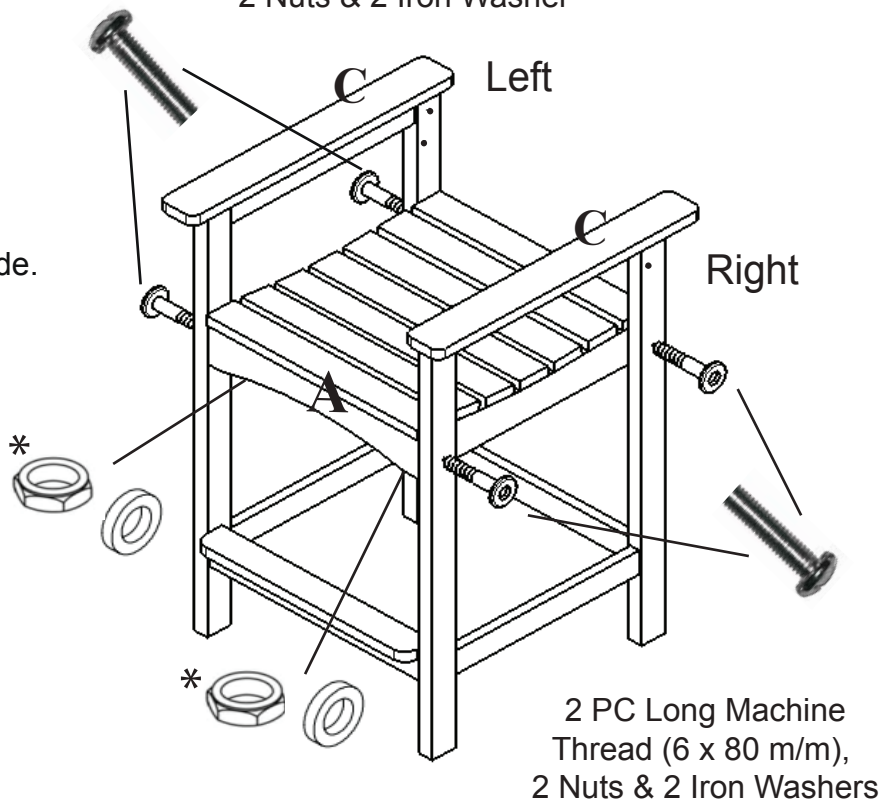

Step 3:

Attach **(B)** Backrest to **(C)** Legs with two Short Machine Threads (6 x 40m/m) for each side.

