

HZ102000TX-WALNUT/
HZ102100TX-BLACK
FOLD-AWAY BAR
Assembly Instruction



For assistance with assembly contact:
Southern Enterprises Inc.
Customer Service 1-800-633-5096
service@seidal.com
www.seidal.com

Supports up to 100 lb

PO 10839

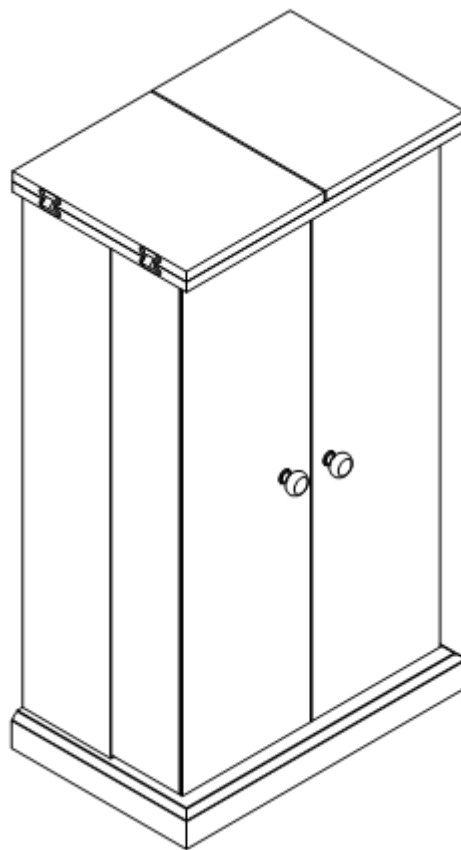

© Southern Enterprises Inc. All Right Reserved.



HZ10200TX-WALNUT / HZ102100TX- BLACK





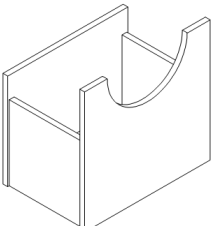
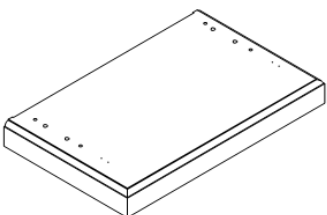
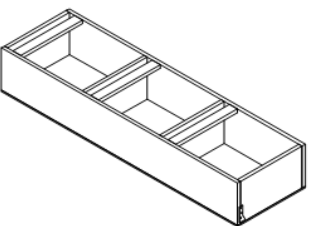
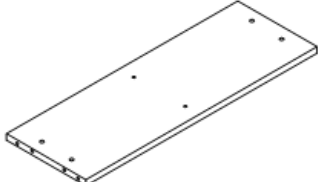
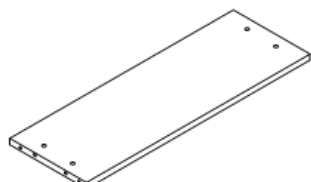
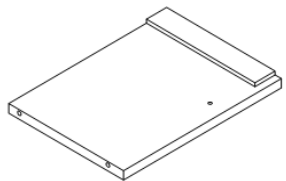
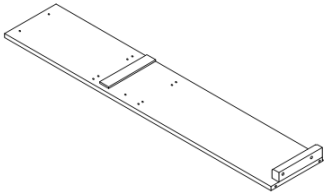
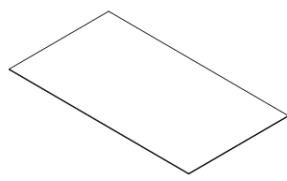
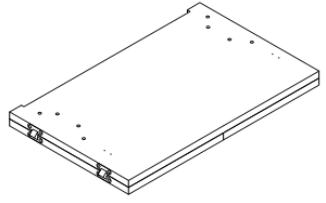
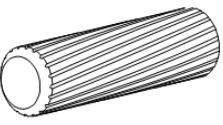

FOLD-AWAY BAR

Parts List

Please review all parts and hardware before disposing of any packaging.
Call Customer Service if missing hardware. Do not return to store/retailer.
Screws shown actual size. Using a screw that is too long will cause damage.
Before beginning assembly, separate each type of screw. Carefully study
the screw diagrams below.

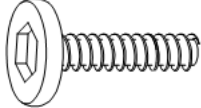
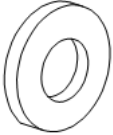
Suggested tools: Phillip head screw driver, power drill, 3/16" drill bit, 24" level, and a tape measure. Unit needs to be hung on wall stud for more security and stability.

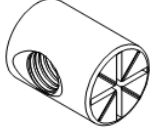
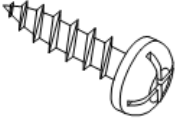
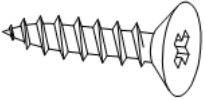
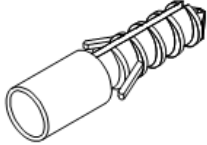
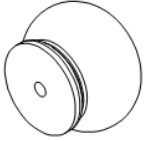
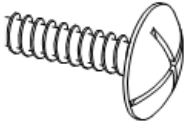
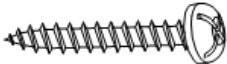
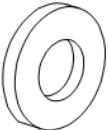
| | | |
|---|---|--|
| (1) Drawer 2PCS  | (2) Bottom Panel 1PC  | (3) Door 2PCS  |
| (4) Top Shelf 1PC  | (5) Bottom Shelf 1PC  | (6) Middle Panel 1PC  |
| (7) Side Panel 2PCS  | (8) Back Panel 1PC  | (9) Top Panel 1PC  |
| (10) Dowel 20PCS  Ø6x30mm | (11) Cam Bolt 8PCS  Ø6x27mm | (12) Cam Lock 8PCS  Ø13x10mm |

| | | |
|--|---|---|
| <p>(13) Cam Bolt 4PCS</p>  <p>Ø6x25mm</p> | <p>(14) Bolt 4PCS</p>  <p>Ø1/4x2-1/4"</p> | <p>(15) Bolt 4PCS</p>  <p>Ø1/4x1"</p> |
| <p>(16) Flat Washer 8PCS</p>  <p>Ø1/4</p> | <p>(17) Lock Washer 8PCS</p>  | <p>(18) Flat Washer 4PCS</p>  |
| <p>(19) Screw 22PCS</p>  <p>Ø3x12mm</p> | <p>(20) Screw 12PCS</p>  <p>Ø3-1/2x14mm</p> | <p>(21) Plastic Anchor 2PCS</p>  |
| <p>(22) Knob 2PCS</p>  | <p>(23) Screw 2PCS</p>  <p>Ø5/32"x1/2"</p> | <p>(24) Screw 2PCS</p>  <p>Ø8x1-1/2"</p> |
| <p>(25) Flat Washer 2PCS</p>  <p>Ø5/32"</p> | <p>(25) Wrench 1PC</p>  | |

Care and Cleaning Instructions:

Before using , wipe with a clean , dry cloth.
Periodically apply furniture wax to renew
The finish. Avoid rubbing or scratching the
surface with rough or abrasive objects.

For replacement parts or questions, please
call Customer Service at 1-800-633-5096.
Do not return product to store. Please call
manufacturer for assistance, questions or
parts.

Assembly Tool Required
No.2 Phillips Screwdriver

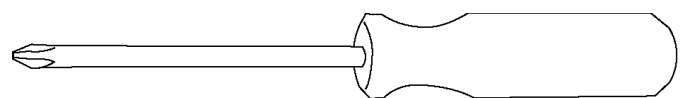

HZ102000TX-WALNUT / HZ102100TX-BLACK

FOLD-AWAY BAR Assembly Instruction

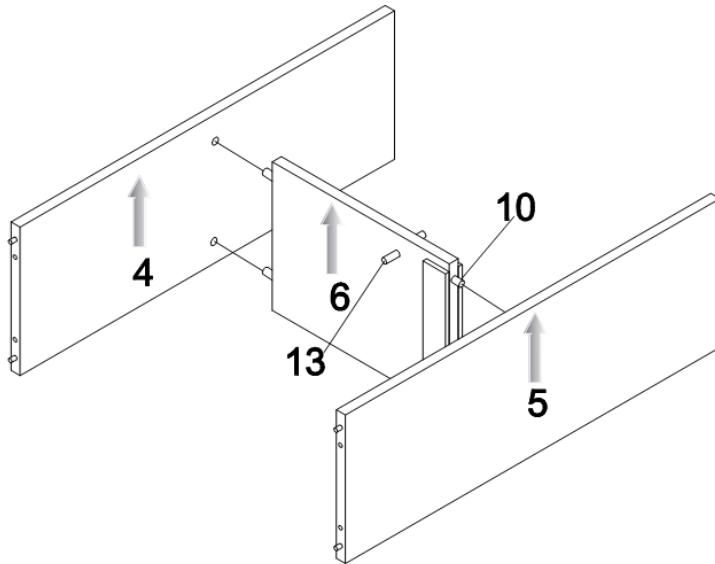

Figure 1

Step 1:

Put all parts on a soft surface to prevent scratches.

Attach middle panel (6) to top shelf (4), bottom shelf (5) by using dowel (10) and cam bolt (13) as shown.

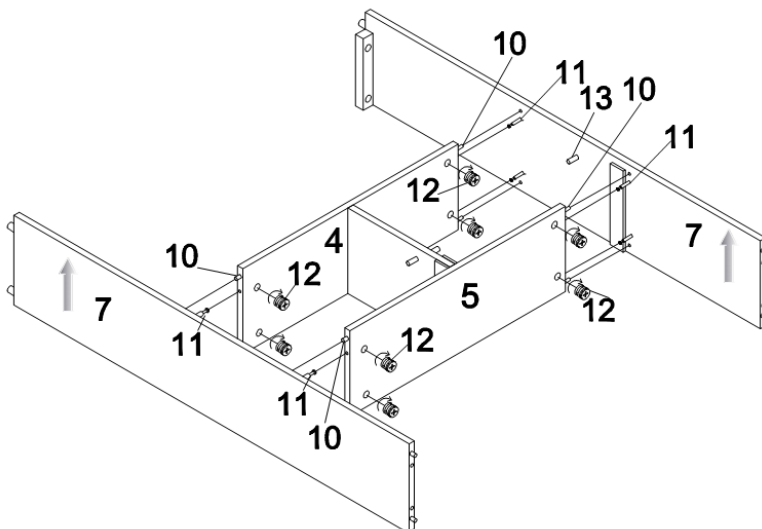

Figure 2

Step 2:

Attach side panel (7) to top shelf (4), bottom shelf (5) by using dowel (10), cam bolt (11), cam lock (12) and cam bolt (13) as shown.

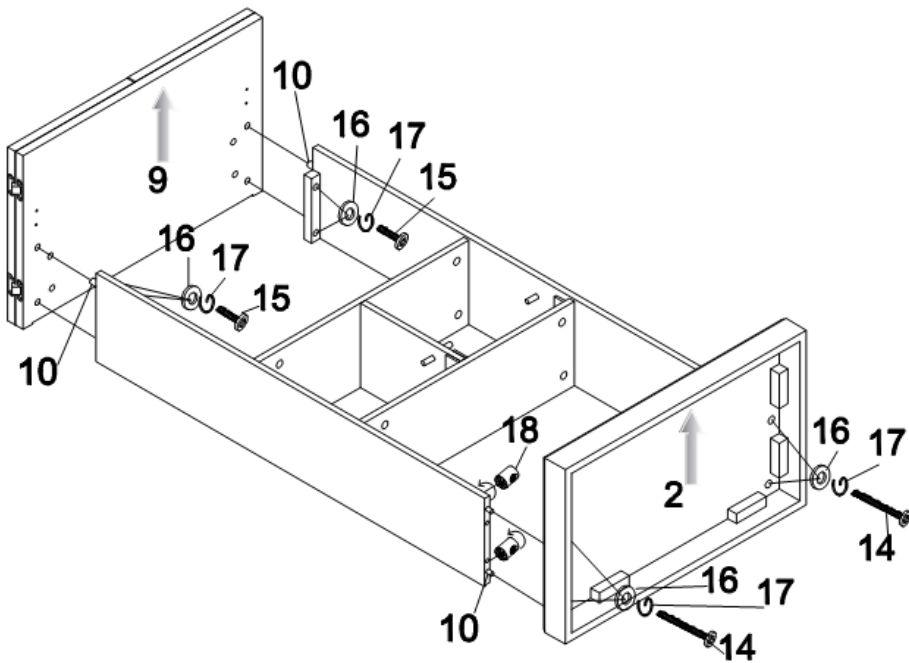

Figure 3

Step 3:

Do not tight all the screws.

Attach top panel (9) and bottom panel (2) to side panel (7) by using dowel (10), bolt (14), bolt (15), flat washer (16), lock washer (17) as shown.

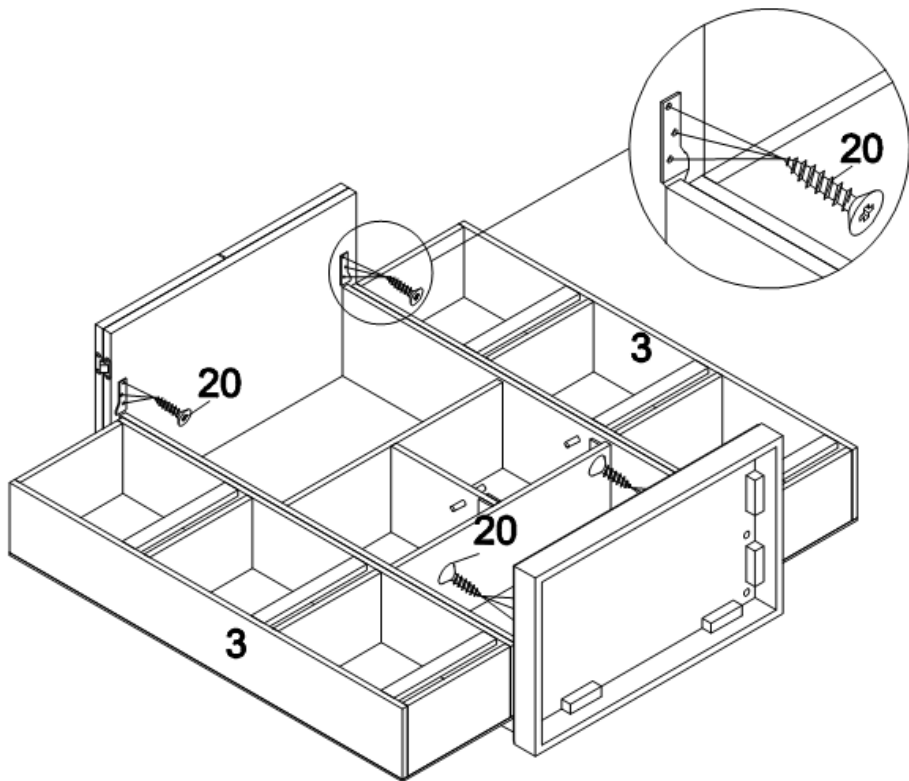

Figure 4

Step 4:

Attach door (3) to body by using screw (20) as shown.

You can tight the screws.

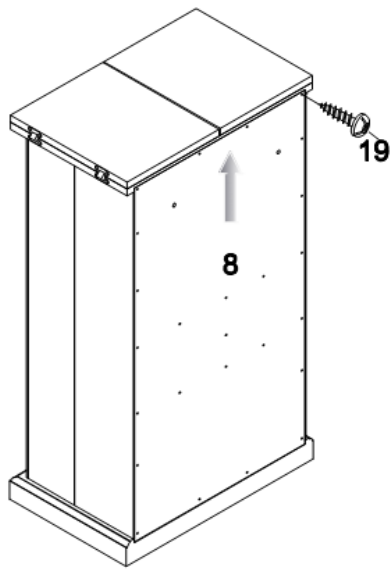
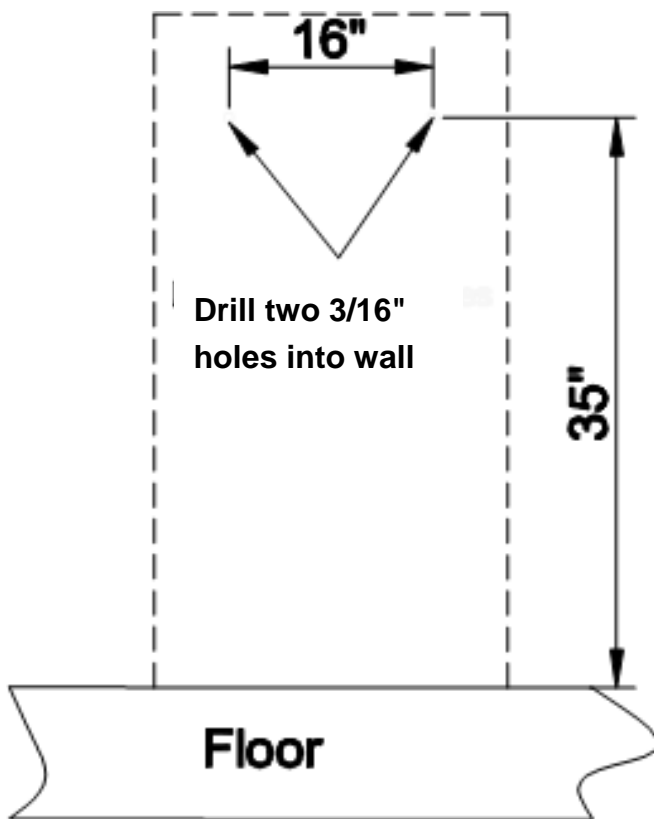

Figure 5

Step 5:

Attach back panel (8) to body by using screw (19) as shown.



Please mount at least 1 screw into a wall stud. Wall anchor is not needed when screwing directly into a wall stud.

Step 6: Measure the wall and mark the location of the center of each mounting holes. See Figure 6.

NOTICE

If your wall studs are 16" apart, please make sure the top 2 holes are located on wall stud. However, at least one top hole must be located on a wall stud.

Using the level, make sure that all marks are level on the wall.

Step 7: Using power drill and 3/16" drill bit, drill two 3/16" holes through the wallboard at the mounting hole marks.

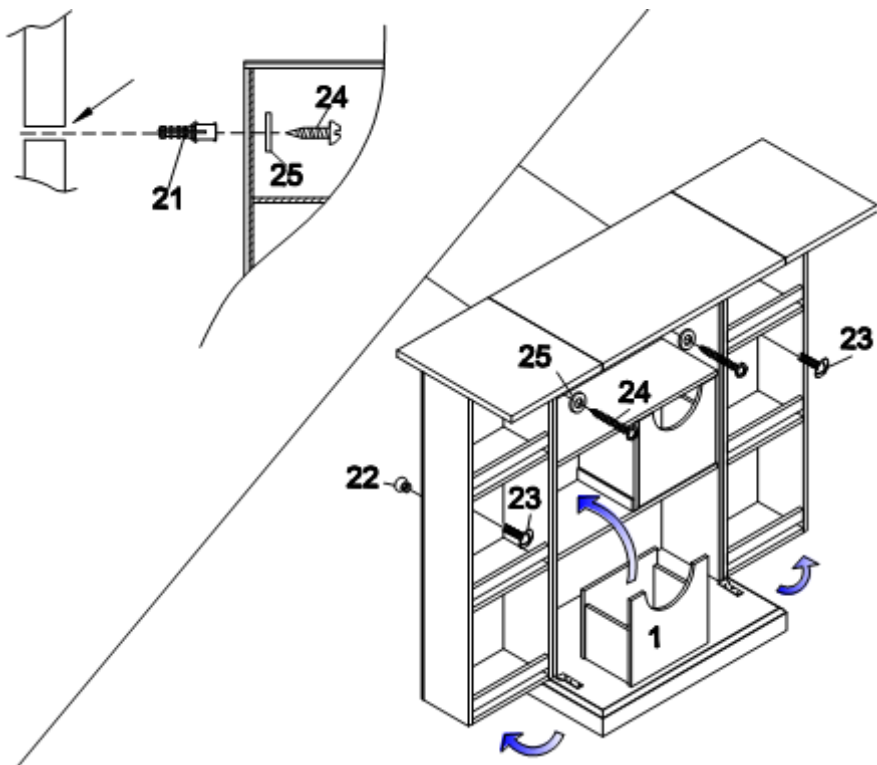

Figure 7

Step 8:

Insert plastic anchors (21) into the two mounting holes. (When doing this, you will need a hammer help you).

Open door and attach fold-away bar (1) to the wall by using flat washer (25), screw (24).

Attach knob (22) and screw (23) to the door.

Insert drawer (1) as shown.



Customer Service 1-800-633-5096

service@seidal.com

Southern Enterprises, Inc.

600 Freeport Parkway, Suite 200

Coppell, Texas 75019

We'd love to hear from you! Email us photos of our products in your home at sei@seidal.com and we might feature it on our site or use it to model one of our inspirational photos.

“PARTS WILL BE SENT IF AVAILABLE FROM SEI” “THIS IS NOT A WARRANTY”

Parts Replacement Form

Customer Information

Name _____

Address _____

City/State/Zip Code _____

Phone Number _____

Please indicate where you purchased this item: Store/ Website/ Catalog

Please indicate color/size/style number:

| Style No | Parts Letter | Parts Description | Quantity Needed |
|----------|--------------|-------------------|-----------------|
| | | | |
| | | | |

Please count, identify and compare parts and hardware list to be sure all parts are present. It may help to divide parts and label them to correspond with part list. Extra hardware may be included. If any items are missing, **please contact Southern Enterprises at 800-633-5096 or in Dallas (972) 869-0111/ 9am – 4pm Mon-Fri Central time if you have product issues with your purchase. Please ask for a customer service representative for issues involving damages or replacement parts. Please ask for a technical assistance representative for any issues with product assembly and product construction. Please contact the retailer that you purchased from for returns.**

Missing or damaged hardware and/ or parts will be replaced free of charge. **We do not sell parts. We do not recommend modifying product(s) and we are not responsible for any damages due to product modification(s).**

If this product has not been purchased from our retail affiliates (within 9 months), we are under no obligation to provide parts or replacements merchandise. Parts will not be available for items arriving fully assembled.

Customer Service 1-800-633-5096

service@seidal.com

Southern Enterprises, Inc.

600 Freeport Parkway, Suite 200

Coppell, Texas 75019

