

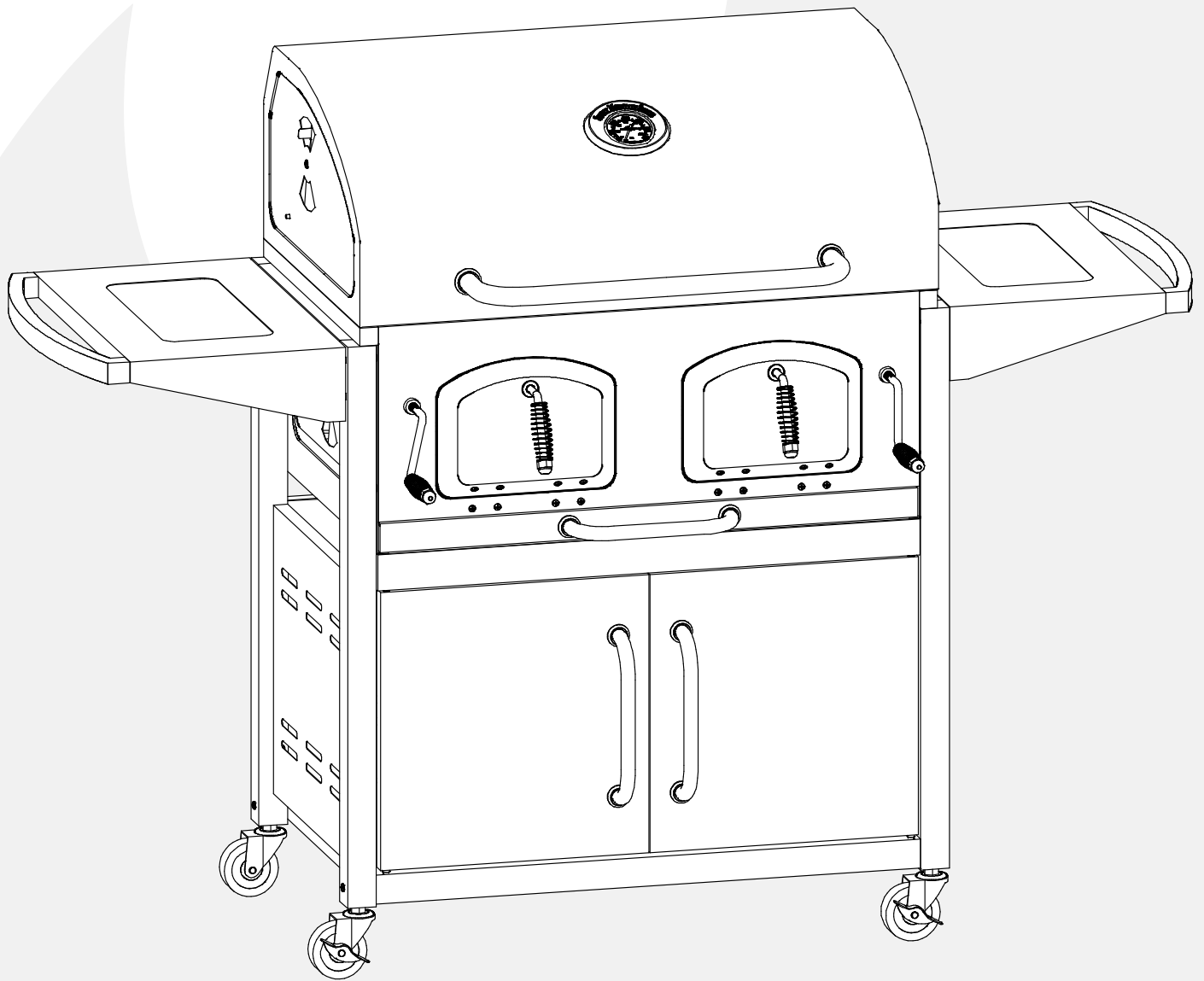

**LANDMANN**  
*bravo*



**Smoky Mountain Series®  
Bravo Premium Charcoal Grill**

**Assembly and Operating  
Instructions for Model:  
591300**

VER. 3, 4/6/2011



**PLEASE READ ALL RULES FOR SAFE  
OPERATION AND FOOD SAFETY BEFORE USING.**



## READ FIRST! RULES FOR BRAVO PREMIUM CHARCOAL GRILL SAFE OPERATION.

- THE GRILL IS FOR OUTDOOR USE ONLY!
- KEEP THE GRILL A MINIMUM OF 10 FT. AWAY FROM BUILDINGS, STRUCTURES, ANY FLAMMABLE ITEMS AND VEHICLES.
- NEVER USE THE GRILL UNDER COVERED PORCHES, AWNINGS, LOW HANGING TREE BRANCHES, TRELLIS, OR OVERHANGS OF ANY KIND.
- NEVER USE INSIDE ENCLOSED AREAS SUCH PATIOS, GARAGES, ENCLOSED ROOMS, BUILDINGS OR TENTS.
- ALWAYS USE THE GRILL ON A HARD, STABLE AND LEVEL SURFACE.
- THE GRILL IS FOR ADULT USE ONLY.
- WARNING! NEVER USE GASOLINE, ALCOHOL OR VOLATILE FLUIDS TO START OR RESTART FIRES. USE CHARCOAL LIGHTER FLUID ONLY TO START CHARCOAL. READ AND FOLLOW CHARCOAL LIGHTER FLUID MANUFACTURER INSTRUCTIONS CLOSELY.
- DO NOT STORE LIGHTER FLUID OR OTHER FLAMMABLE LIQUIDS OR MATERIALS IN THE STORAGE CABINET.
- KEEP CHILDREN AND PETS AWAY WHILE THE GRILL IS BEING USED.
- MITTENS OR GLOVES WILL BE NEEDED TO OPEN THE LID AND DOORS AS SURFACES WILL BE HOT.
- MOST SURFACES OF THIS GRILL BECOME HOT, USE CAUTION.
- DO NOT MOVE THE GRILL WHILE IT IS BEING USED.
- DO NOT LEAVE UNATTENDED AT ANY TIME WHILE IN USE.
- DO NOT USE IN WINDY CONDITIONS.
- USE CAUTION WHEN OPENING THE LID AS HOT STEAM OR A FLARE UP COULD CAUSE BURNS.
- BEFORE EACH USE, MAKE SURE THE GRILL IS IN GOOD WORKING CONDITION.
- FOR LONGER PRODUCT LIFE, KEEP THE CHARCOAL FIRES TO A RESPECTABLE SIZE, DO NOT OVERLOAD.
- DO NOT ALLOW CHARCOAL TO COME IN CONTACT WITH THE GRILL SIDES, KEEP CHARCOAL INSIDE CHARCOAL PANS.
- ALLOWING THE CHARCOAL TO CONTACT THE GRILL SIDES WILL GREATLY REDUCE THE LIFE OF THE METAL AND THE FINISH.
- DO NOT ALTER THE GRILL IN ANY WAY.
- DO NOT USE THE GRILL UNTIL IT IS COMPLETELY ASSEMBLED WITH ALL PARTS SECURELY TIGHTENED.
- THE SIDE SHELVES CAN HOLD 15 LBS. SAFELY, DO NOT PUT MORE THAN 15 LBS. ON THE SIDE SHELVES.
- USE CAUTION WHEN HANDLING THE CAST IRON COOKING GRATES, CAST IRON CAN CHIP, CRACK OR BREAK IF HIT OR STRUCK WITH A SHARP OBJECT. DO NOT DROP THE CAST IRON GRATES ON THE GROUND!
- DO NOT LEAN OR PUSH DOWN ON THE SIDE SHELVES OR SIDE SHELF HANDLES.
- USE CAUTION AFTER THE FIRE HAS BEEN EXTINGUISHED- SURFACES WILL REMAIN HOT FOR SOME TIME.
- BE SURE ALL COALS ARE COLD BEFORE DISPOSING.
- DISPOSE OF COALS PROPERLY.
- THE GRILL MUST BE COMPLETELY COOLED OFF AND ALL EMBERS MUST BE EXTINGUISHED BEFORE ANY COVER CAN BE USED.



## FOOD SAFETY

- RAW MEAT AND POULTRY HAS TO BE KEPT SEPARATE FROM READY TO EAT FOOD.
- USE CLEAN PLATTERS AND UTENSILS FOR HANDLING COOKED FOODS.
- COOK POULTRY AND MEATS THOROUGHLY TO KILL BACTERIA.
- USE INSTANT-READ THERMOMETER TO ENSURE PROPER INTERNAL FOOD TEMPERATURES.
- KEEP PREPARED FOOD AND LEFTOVERS REFRIGERATED.
- WASH HANDS, UTENSILS AND SURFACES WITH SOAP AND HOT WATER PRIOR TO AND AFTER HANDLING RAW MEAT AND POULTRY.



**LANDMANN**  
bravo

## PARTS LIST

When unpacking the grill from the carton, make sure you find and become familiar with all the parts listed below. Use caution as some parts may have sharp edges.

### GRILL PARTS

### QTY

A.	LID AND COOKING CHAMBER PRE-ASSEMBLY .....	1
B.	LEG, FRONT RIGHT.....	1
C.	LEG, FRONT LEFT .....	1
D.	LEG, BACK RIGHT.....	1
E.	LEG, BACK LEFT .....	1
F.	CABINET PANEL, SIDE .....	2
H.	CABINET PANEL, BACK .....	1
J.	CABINET DOOR WITH HANDLE, RIGHT.....	1
K.	CABINET DOOR WITH HANDLE, LEFT.....	1
L.	BOTTOM SHELF WITH DOOR STOP.....	1
M.	ASH TRAY.....	1
N.	SIDE SHELF WITH HANDLE .....	2
P.	BLOCKING PLATE .....	1
Q.	FRONT CONNECTOR WITH DOOR STOP.....	1
R.	LEG CONNECTOR .....	1
T.	CHARCOAL PAN ASSEMBLY, RIGHT .....	1
U.	CHARCOAL PAN ASSEMBLY, LEFT .....	1
V.	CAST IRON COOKING GRATE .....	2
W.	WARMING GRATE .....	1
X.	LID HANDLE .....	1
Y.	SMALL HANDLE .....	1
AA.	CASTER .....	2
AB.	LOCKING CASTER.....	2
AC.	VENT.....	4
AD.	CHARCOAL PAN ADJUSTMENT CRANK HANDLE ASSEMBLY .....	2
AE.	ACCESS DOOR HANDLE ASSEMBLY .....	2
AF.	THREADED SLEEVE BRACKET .....	2
AG.	TEMPERATURE GAUGE WITH BRASS HEXNUT.....	1
AH.	LOGO PLATE .....	1
AJ.	LARGE FINISHING WASHER .....	2
AK.	SMALL FINISHING WASHER.....	2
AP.	M5 x 15MM BOLT .....	4
AQ.	M6 x 10MM BOLT .....	40
AR.	M6 x 50MM BOLT .....	4
AT.	M6 KEP HEXNUT .....	8
AX.	M6 LOCKING HEXNUT.....	4
AY.	M4 x 10MM BOLT .....	2
AZ.	M6 x 15MM BOLT .....	4
BA.	M6 x 10MM ROUND HEAD BOLT .....	8



### WARNING!

### CARBON MONOXIDE HAZARD!

BURNING WOOD OR CHARCOAL PRODUCES CARBON MONOXIDE, WHICH HAS NO ODOR AND CAN CAUSE DEATH IF BURNED IN ENCLOSED AREAS. NEVER BURN WOOD OR CHARCOAL INSIDE HOMES, VEHICLES, TENTS OR ANY OTHER ENCLOSED AREAS.

# HARDWARE AND SMALL PART LISTING

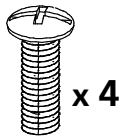

**AP**

(4) M5 x 15MM  
BOLT

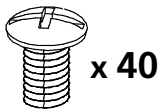

**AQ**

(40) M6 x 10MM  
BOLT

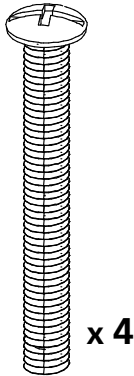

**AR**

(4) M6 x 50MM  
BOLT

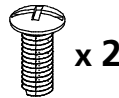

**AY**

(2) M4 x 10MM  
BOLT

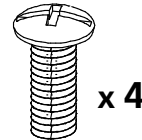

**AZ**

(4) M6 x 15MM  
BOLT

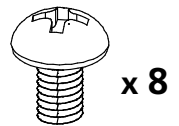

**BA**

(8) M6 x 10MM  
ROUND HEAD BOLT

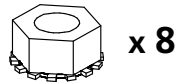

**AT**

(8) M6 KEK  
HEXNUT



**AX**

(4) M6 LOCKING  
HEXNUT

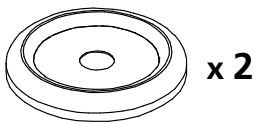

**AJ**

(2) LARGE  
FINISHING WASHER

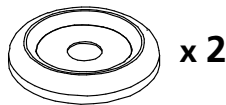

**AK**

(2) SMALL  
FINISHING WASHER

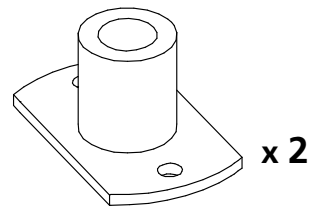

**AF**

(2) THREADED  
SLEEVE BRACKET

# PART LISTING

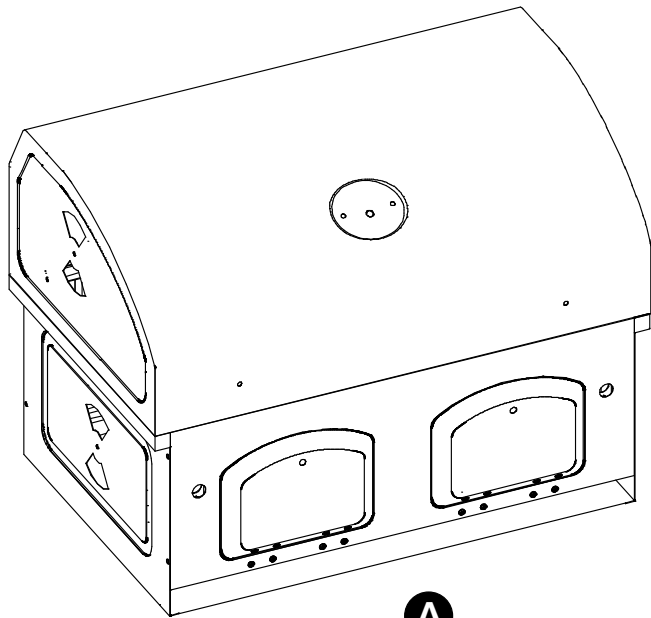

**A**  
(1) LID AND COOKING  
CHAMBER ASSEMBLY

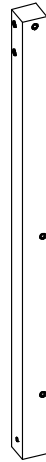

**E**  
(1) LEG,  
BACK LEFT



**C**  
(1) LEG,  
FRONT LEFT



**D**  
(1) LEG,  
BACK RIGHT

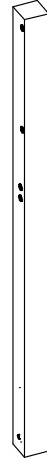

**B**  
(1) LEG,  
FRONT RIGHT

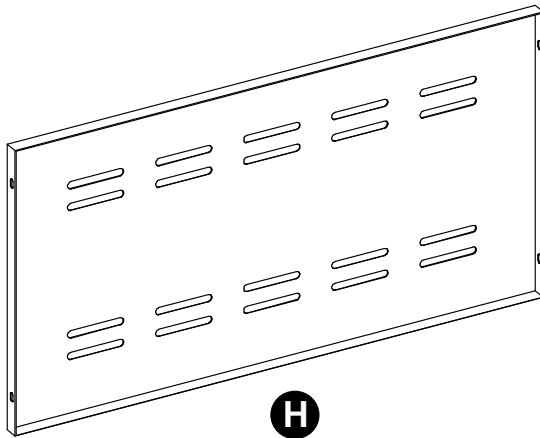

**H**  
(1) CABINET  
PANEL, BACK

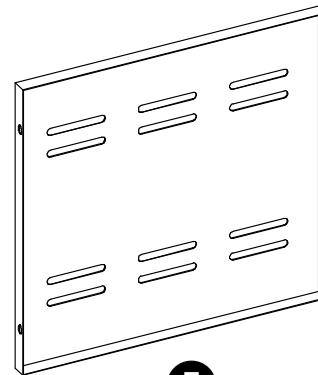

**F**  
(2) CABINET  
PANEL, SIDE

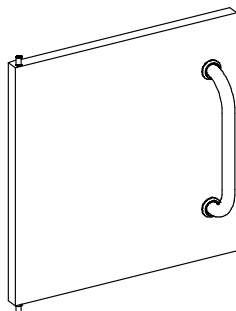

**K**  
(1) CABINET DOOR WITH  
HANDLE, LEFT

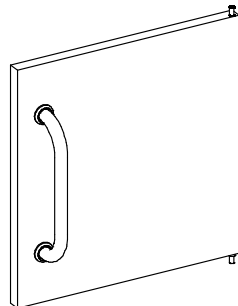

**J**  
(1) CABINET DOOR WITH  
HANDLE, RIGHT

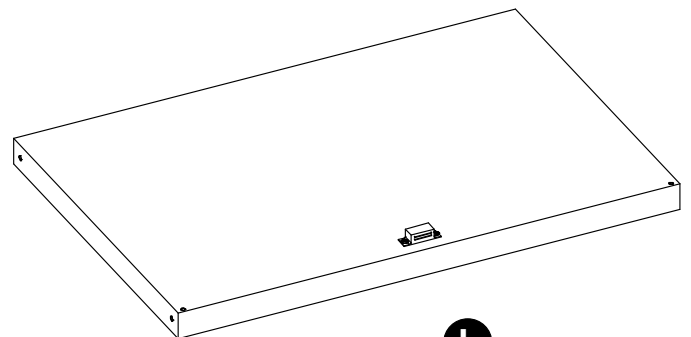

**L**  
(1) BOTTOM SHELF  
WITH DOOR STOP



# PART LISTING

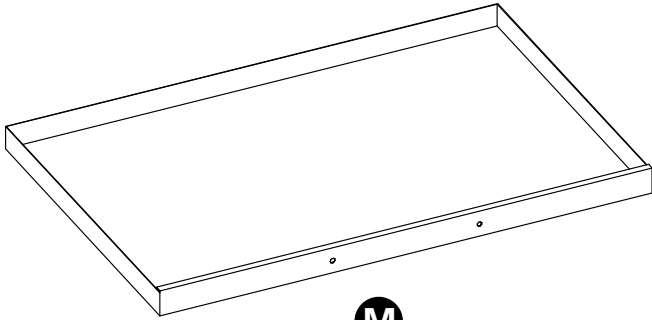

**M**  
(1) ASH TRAY

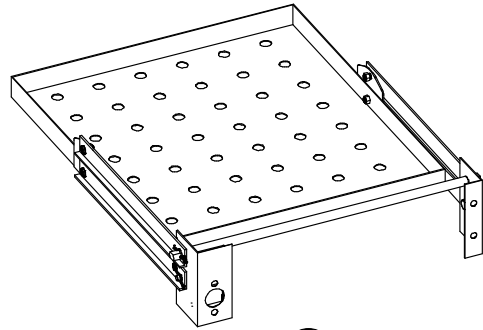

**U**  
(1) CHARCOAL PAN  
ASSEMBLY, LEFT

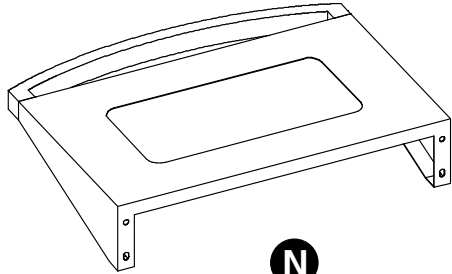

**N**  
(2) SIDE SHELF  
WITH HANDLE

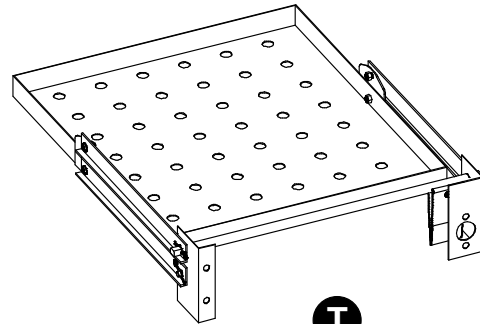

**T**  
(1) CHARCOAL PAN  
ASSEMBLY, RIGHT

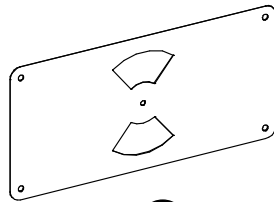

**P**  
(1) BLOCKING  
PLATE

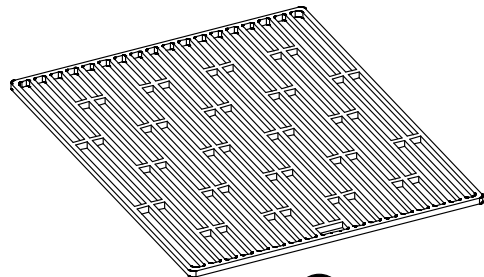

**V**  
(2) CAST IRON  
COOKING GRATE

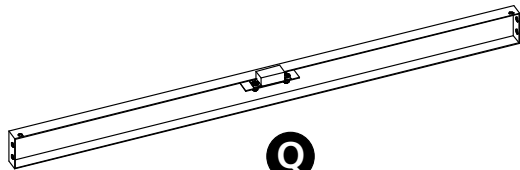

**Q**  
(1) FRONT CONNECTOR  
WITH DOOR STOP



**R**  
(2) LEG CONNECTOR

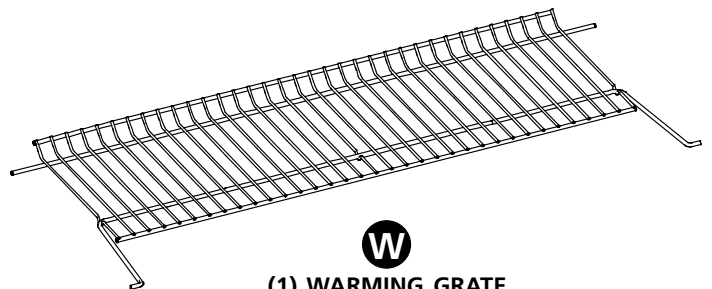

**W**  
(1) WARMING GRATE

# PART LISTING

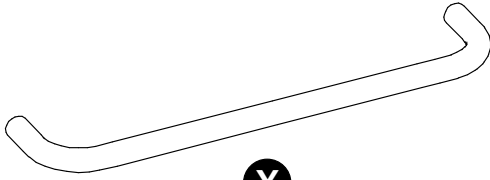

**X**  
(1) LID HANDLE

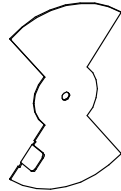

**AC**  
(4) VENT

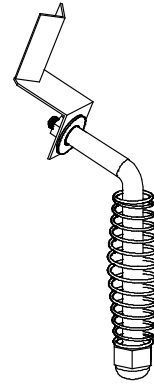

**AE**  
(2) ACCESS DOOR  
HANDLE ASSEMBLY



**Y**  
(1) SMALL HANDLE

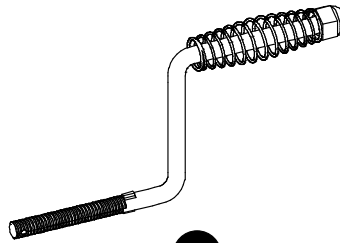

**AD**  
(2) CHARCOAL PAN  
ADJUSTMENT CRANK  
HANDLE ASSEMBLY

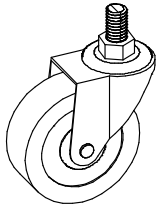

**AA**  
(2) CASTER

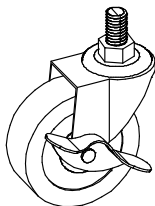

**AB**  
(2) LOCKING  
CASTER

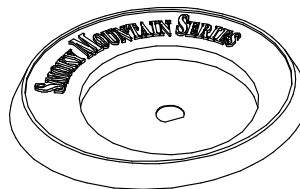

**AH**  
(1) LOGO PLATE

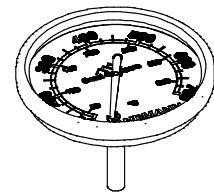

**AG**  
(1) TEMPERATURE GAUGE  
WITH BRASS HEXNUT

# BRAVO CHARCOAL GRILL ASSEMBLY INSTRUCTIONS



A Phillips or plain screwdriver, adjustable wrench and needle nose pliers are needed for assembly.

Assembly time: 75 minutes



For easier reading and visual reference, part letters are described in either black or gray circles in each step.

### EXAMPLE



Black circle part letters are parts added for the step.



Gray circle part letters are reference parts for the step.

### STEP 1: ASSEMBLE THE LEGS TO SIDE CABINET PANELS

Arrange the (4) legs [ B,C,D,E ] in the correct orientation and assemble the side cabinet panels [ F ] to the legs using (4) 10MM bolts [ AQ ] on each side. Tighten bolts securely.

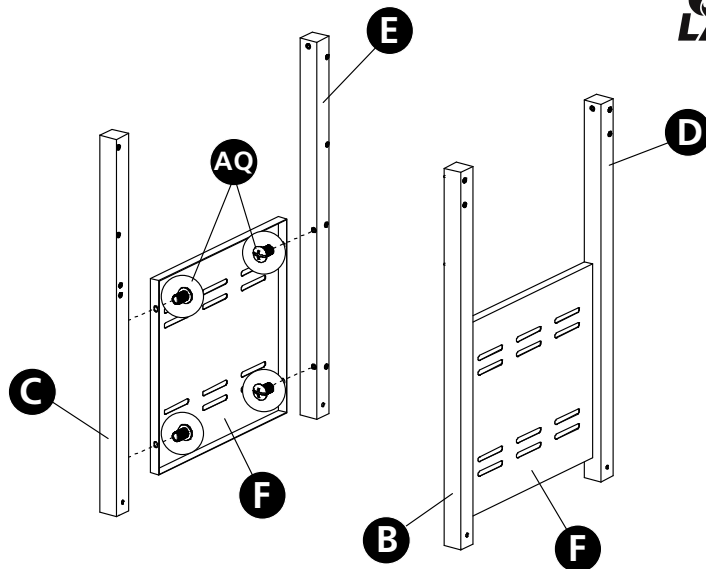

STEP 1

### STEP 2: ASSEMBLE THE BOTTOM SHELF TO THE LEGS

Assemble the bottom shelf [ L ] to the legs using (4) 50MM bolts [ AR ] and (4) M6 kep hexnuts [ AT ]. Tighten all bolts securely.

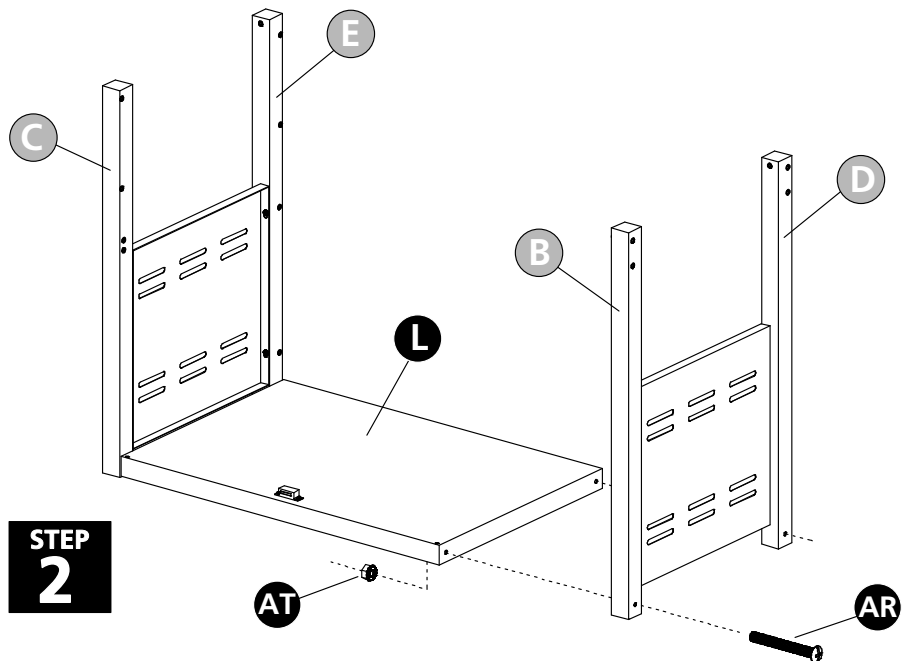

STEP 2

### STEP 3: ASSEMBLE THE BACK PANEL

Assemble the back panel [ H ] to the legs [ D,E ] using (4) 10MM bolts [ AQ ]. Tighten bolts securely.

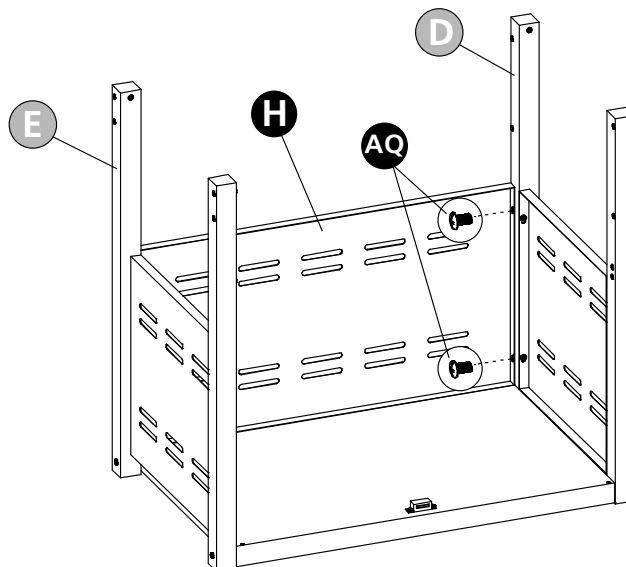

STEP 3

**DO NOT RETURN PRODUCT TO THE STORE. IF YOU HAVE QUESTIONS OR HAVE TROUBLE WITH ASSEMBLY, PLEASE CALL 1-877-347-4557 FOR ASSISTANCE.**

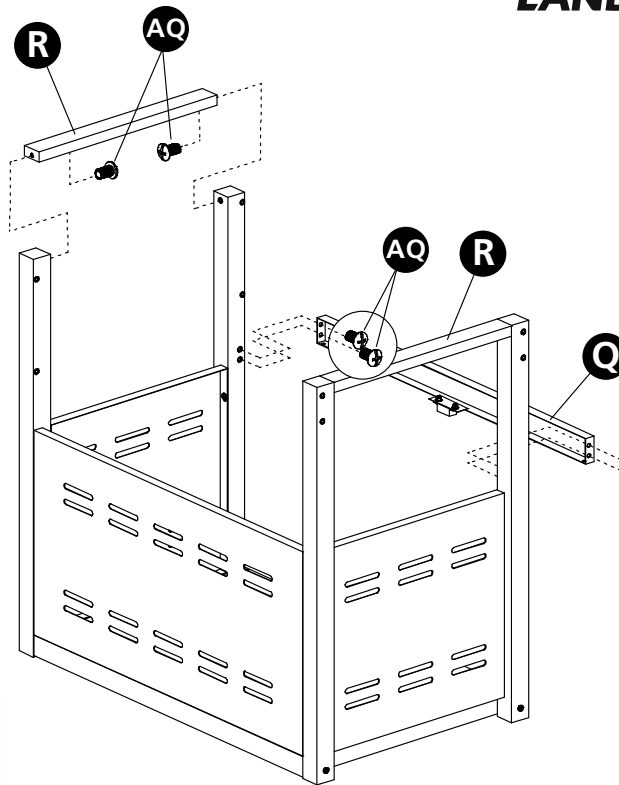

## STEP 4

### STEP 4: ASSEMBLE THE FRONT AND LEG CONNECTORS

First, assemble the front connector plate [ Q ] as shown to the legs using (4) 10MM bolts [ AQ ]. Tighten the bolts securely.

Next, assemble the (2) leg connectors [ R ] to the legs as shown using (4) 10MM bolts [ AQ ]. Tighten bolts securely.

### STEP 5: ASSEMBLE THE CASTERS

Carefully turn the leg and cabinet assembly over. Assemble the (4) casters [ AA,AB ] to the leg threaded inserts.

Assemble the locking casters on the front side.

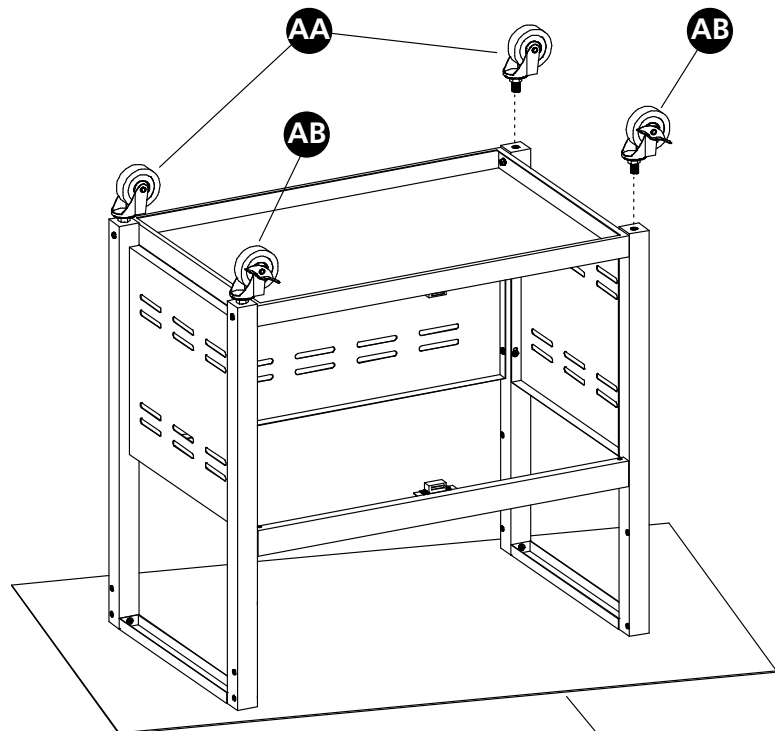

CARDBOARD OR BLANKET

## STEP 5

**DO NOT RETURN PRODUCT TO THE STORE.  
IF YOU HAVE QUESTIONS OR HAVE  
TROUBLE WITH ASSEMBLY, PLEASE CALL  
1-877-347-4557 FOR ASSISTANCE.**

## STEP 6: ASSEMBLE THE CABINET DOORS

Carefully turn the leg and cabinet assembly back over onto the casters.

Assemble the cabinet doors [ J,K ] to the bottom shelf. First identify the left and right doors. Put the fixed pins into the bottom shelf [ L ] and press the top pins to insert into the front connector plate [ Q ].

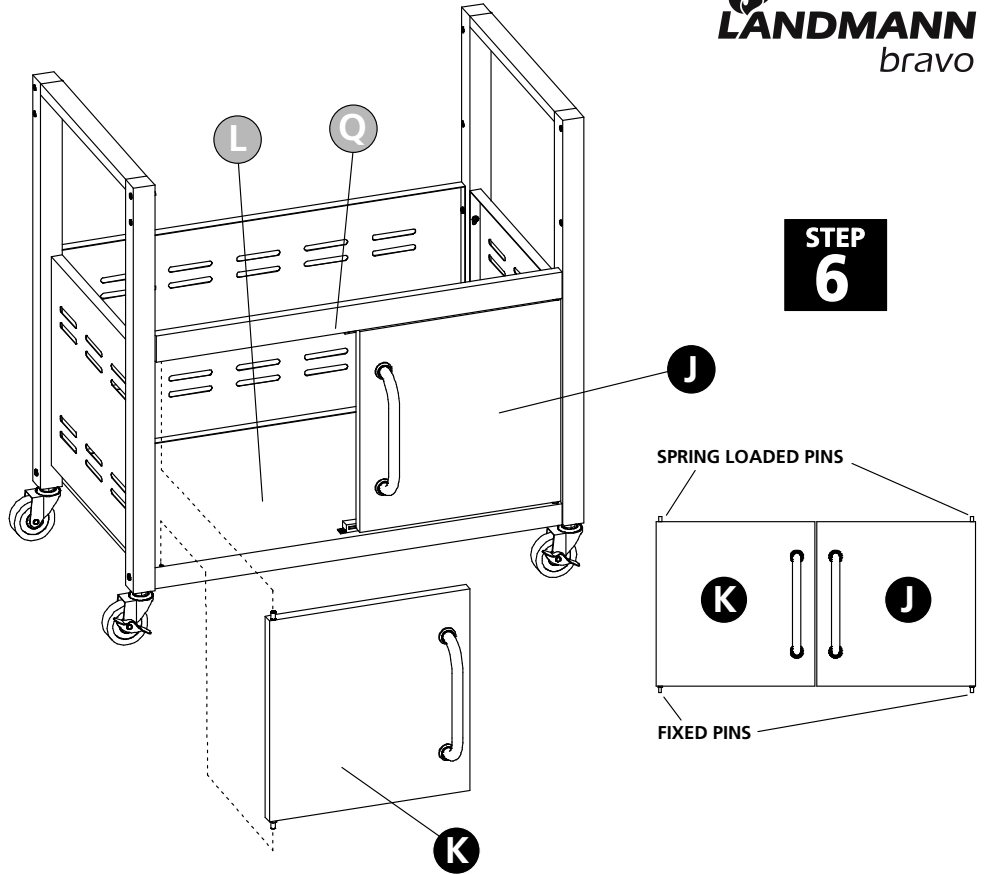

## STEP 7: ASSEMBLE LID AND COOKING CHAMBER TO THE LEGS

**⚠ ATTENTION !!** 2 persons are needed for this step.

**⚠ CAUTION !!** Avoid pinched fingers and hands! Keep fingers and hands clear of the connection area.

First make sure the locking casters are in the locked position so the leg and cabinet will not move around.

Very carefully place the lid and cooking chamber [ A ] onto the legs. Adjust so the front of the cooking chamber is flush with the front of the legs and resting on top of the legs. See STEP 7A.

Carefully open the lid and keep the cooking chamber steady. Use (8) 10MM bolts [ BA ] to assemble the cooking chamber to the legs. Tighten all bolts securely. See STEP 7B.

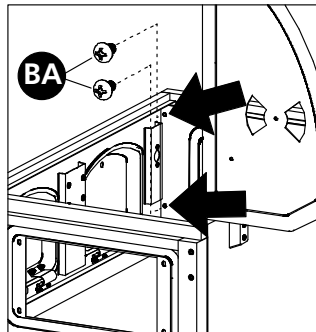

## STEP 7B

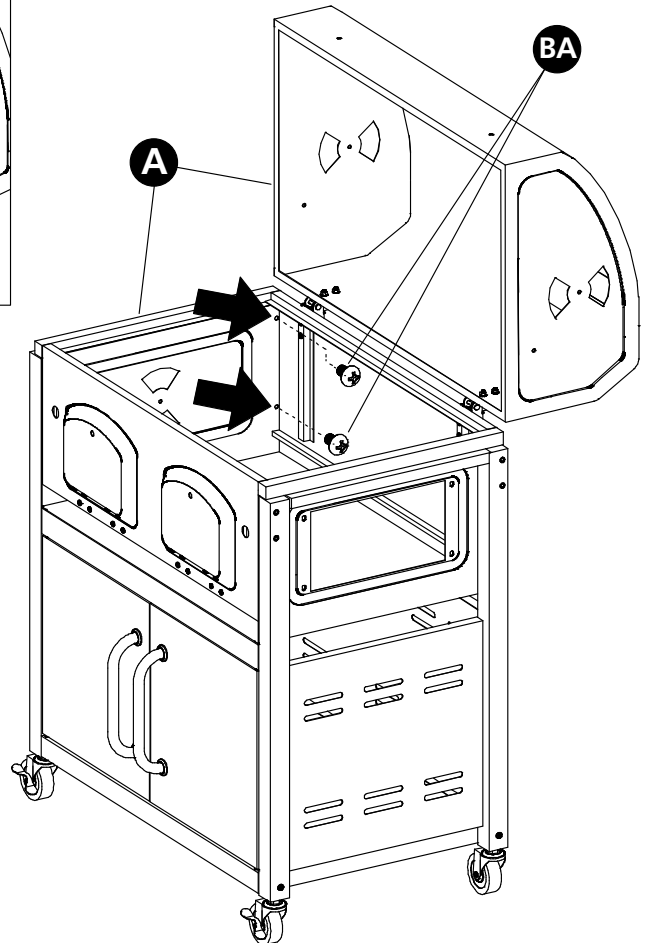

## STEP 7A

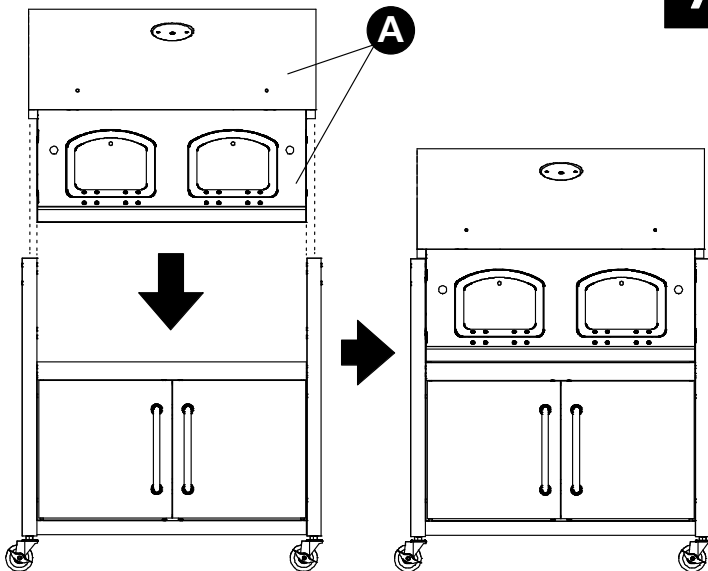

**STEP 8: ASSEMBLE LID HANDLE AND TEMPERATURE GAUGE**

Assemble the lid handle [ X ] to the lid using (2) 15MM bolts [ AZ ] and (2) large finishing washers [ AJ ]. Assemble as shown.

Remove the brass hexnut from the temperature gauge [ AG ] and align the probe key with the lock on the logo plate [ AH ].

Align the temperature gauge and logo plate probe and pins with the holes in the lid. Secure to lid with the brass hexnut.

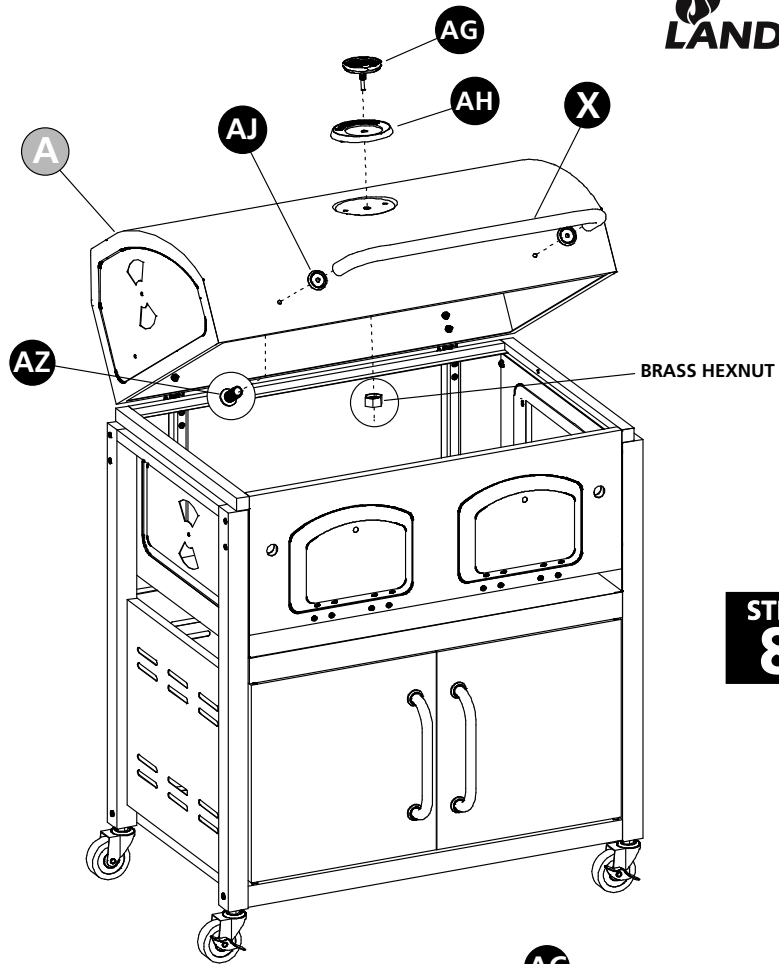

**STEP  
8**

**STEP 9: ASSEMBLE THE BLOCKING PLATE AND VENTS**

Assemble (2) vents [ AC ] to the lid using (1) M6 x 10MM bolt [ AQ ] and (1) M6 locking hexnut [ AX ] per vent. Tighten enough to allow for some friction.

Assemble the blocking plate [ P ] to the the cooking chamber using (4) M6 x 10MM bolts [ AQ ] and (4) M6 kep hexnuts. Tighten bolts securely.

Assemble (1) vent to the cooking chamber and (1) vent to the blocking plate using (1) M6 x 10MM bolt [ AQ ] and (1) M6 locking hexnut [ AX ] per vent. Tighten enough to allow for some friction.

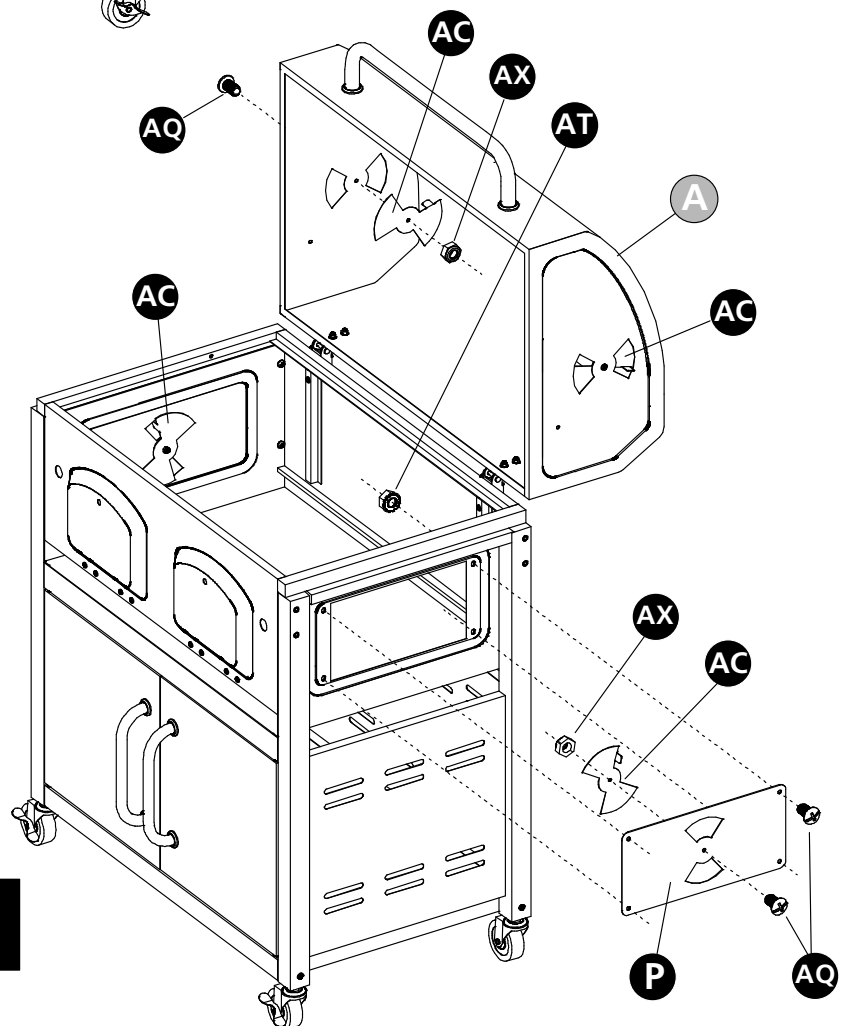

**STEP  
9**

**DO NOT RETURN PRODUCT TO THE STORE.  
IF YOU HAVE QUESTIONS OR HAVE  
TROUBLE WITH ASSEMBLY, PLEASE CALL  
1-877-347-4557 FOR ASSISTANCE.**

# BRAVO CHARCOAL GRILL ASSEMBLY INSTRUCTIONS



## STEP 10: ASSEMBLE THE CHARCOAL PAN ASSEMBLIES

Assemble one assembly at a time to avoid mixing up parts.

Identify the right charcoal pan assembly [ T ]. See STEP 10A. Remove the push plate rod from the right charcoal pan assembly [ T ]. Using needle nose pliers or pliers, pull the (2) locking pins from the rod ends. Remove the push plate rod from the (2) top support bars and set aside. See STEP 10B.

Align the holes and assemble the charcoal pan assembly to the cooking chamber.

Start on the push plate side. Insert the threaded sleeve bracket [ AF ] into the hole and assemble the side with (2) M5 x 15MM bolts [ AP ] as shown. See STEP 10C.

Return the push plate rod to the assembly inserting the ends of the rod into the brackets and support bars. Secure the rod with the locking pins. See STEP 10D.

Finish by using (2) M6 x 10MM bolts [ AQ ] to assemble the opposite side to the cooking chamber. See STEP 10E.

Assemble the left charcoal pan [ U ] assembly the same way.

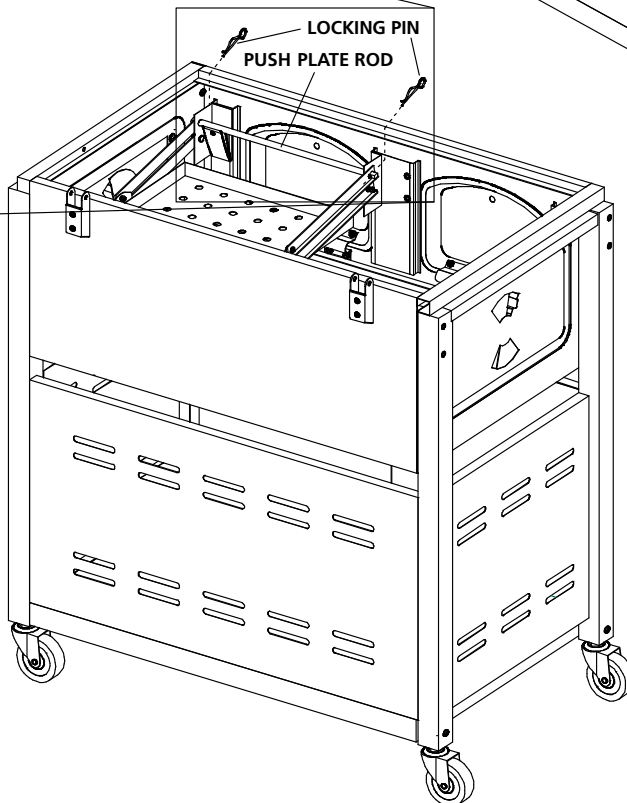
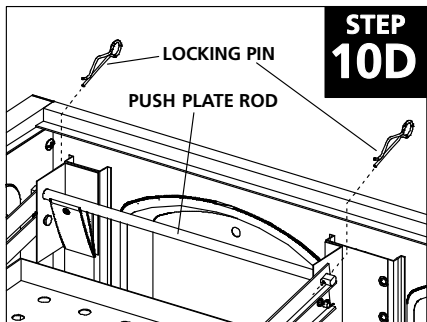
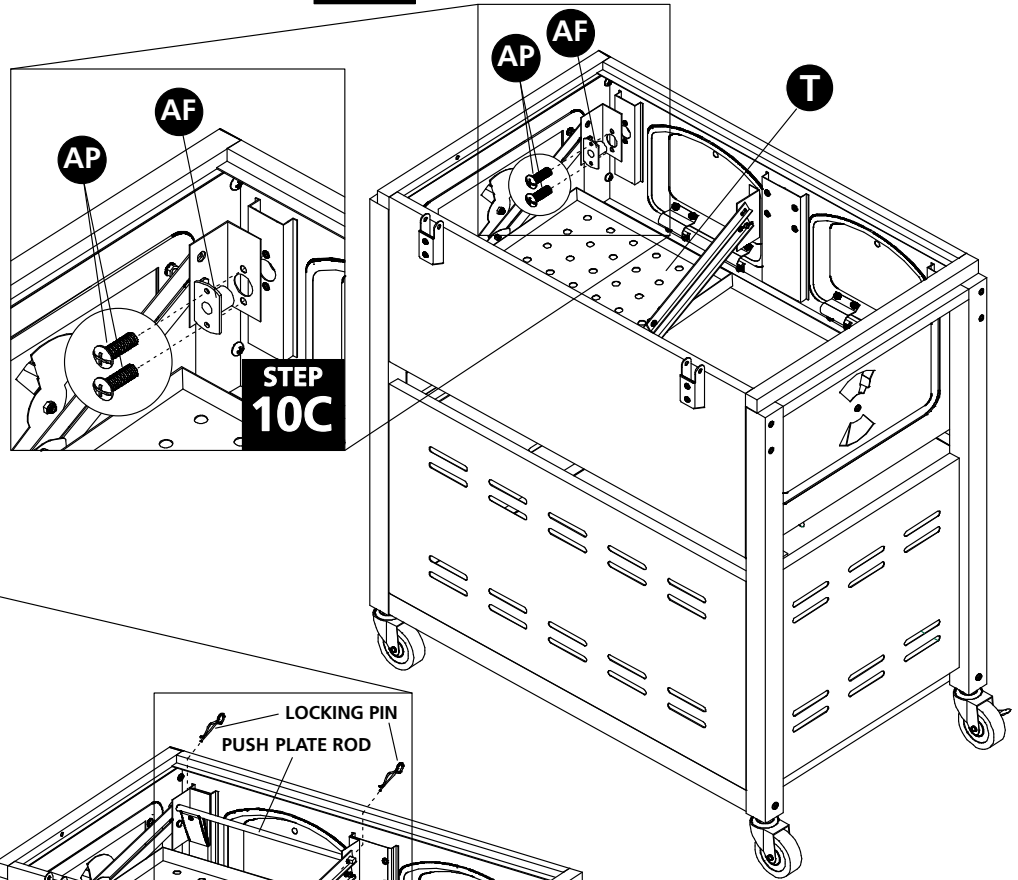
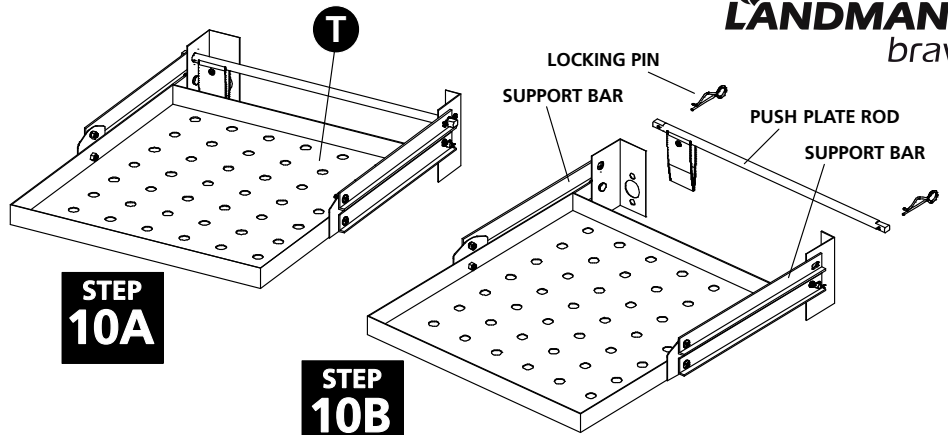

**NOTE** LID NOT SHOWN IN DRAWINGS FOR CLARITY

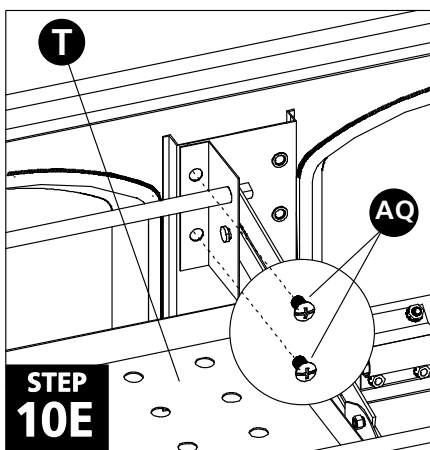



## STEP 11: ASSEMBLE THE CHARCOAL PAN CRANK ADJUSTMENT HANDLES

Thread the charcoal pan crank adjustment handles [ AD ] into the threaded sleeve brackets [ AF ].

Crank the pans up and down a few times to make sure they work properly. Secure the handle with (1) M4 x 10MM bolt [ AY ] per handle. See STEP 11A.

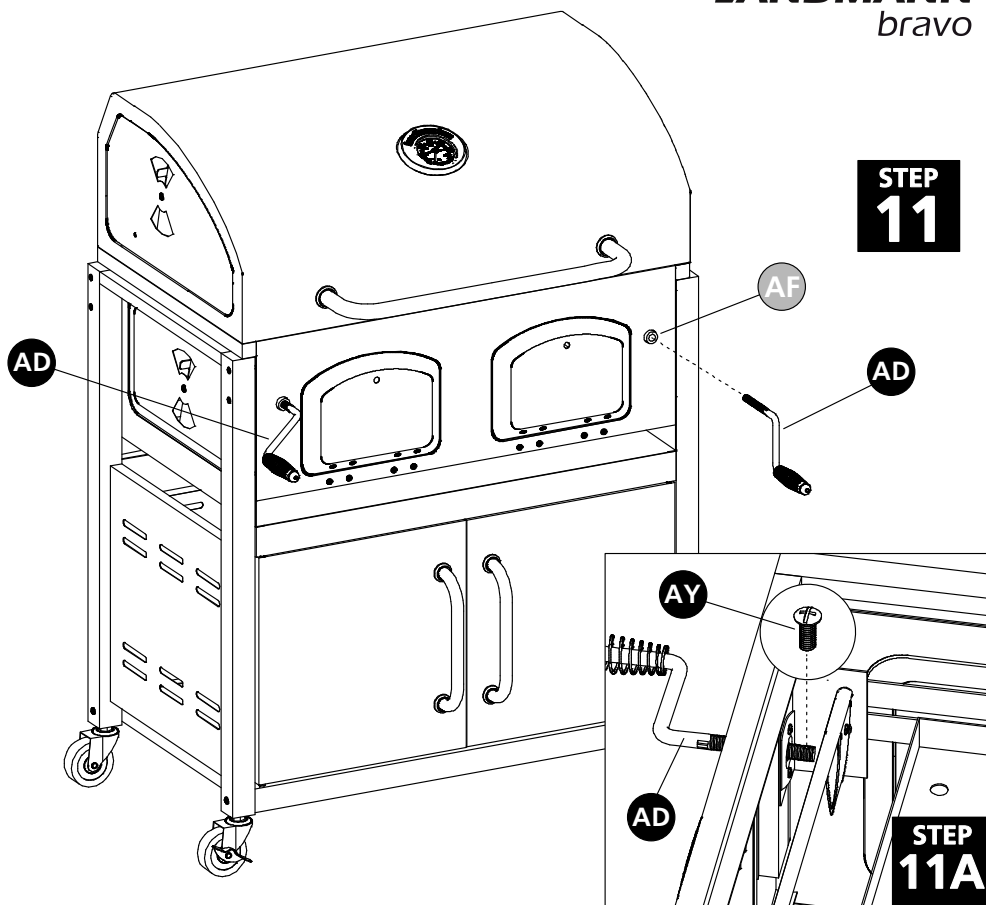

## STEP 12: ASSEMBLE THE ACCESS DOOR HANDLES

Cut the nylon ties and remove the ties, polybag and packing material around the access doors.

Remove the latch and M6 kep hexnut from the access door handle [ AE ]. The flat washer remains and assembles on the outside. Insert the threaded end of the handle into the access door hole.

Slide the latch onto the handle so it aligns with the key. Note the position of the latch. Secure with the M6 kep hexnut. Tighten securely.

Assembly is the same for the other side.

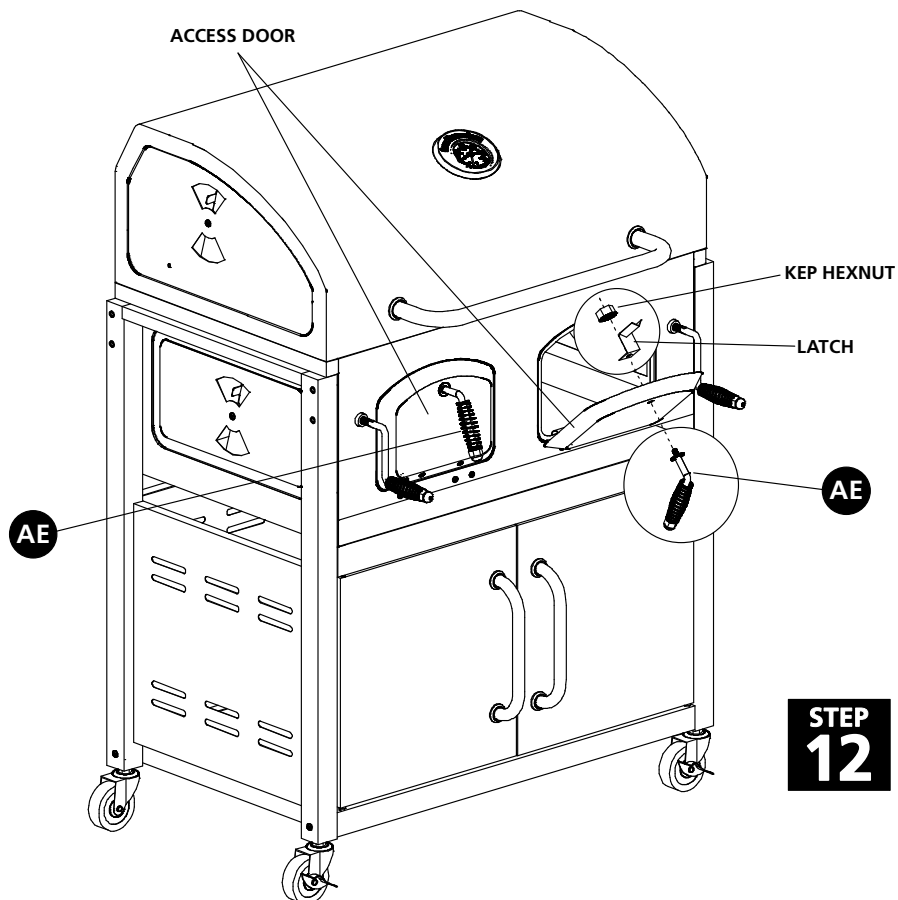

**DO NOT RETURN PRODUCT TO THE STORE. IF YOU HAVE QUESTIONS OR HAVE TROUBLE WITH ASSEMBLY, PLEASE CALL 1-877-347-4557 FOR ASSISTANCE.**

**STEP 12**



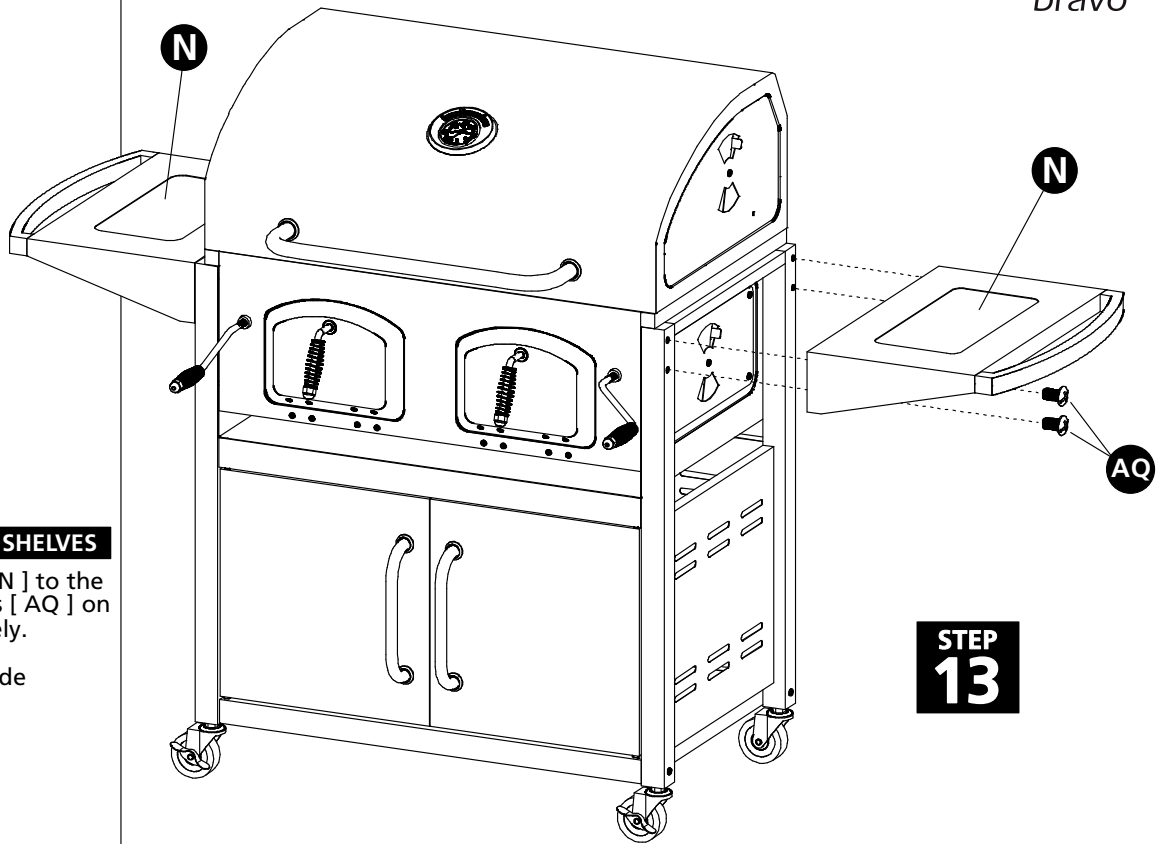

**STEP 13: ASSEMBLE THE SIDE SHELVES**

Assemble the (2) side shelves [ N ] to the legs using (4) M6 x 10MM bolts [ AQ ] on each side. Tighten bolts securely.

Note the weight limit on the side shelves is 15 lbs.

**STEP  
13**

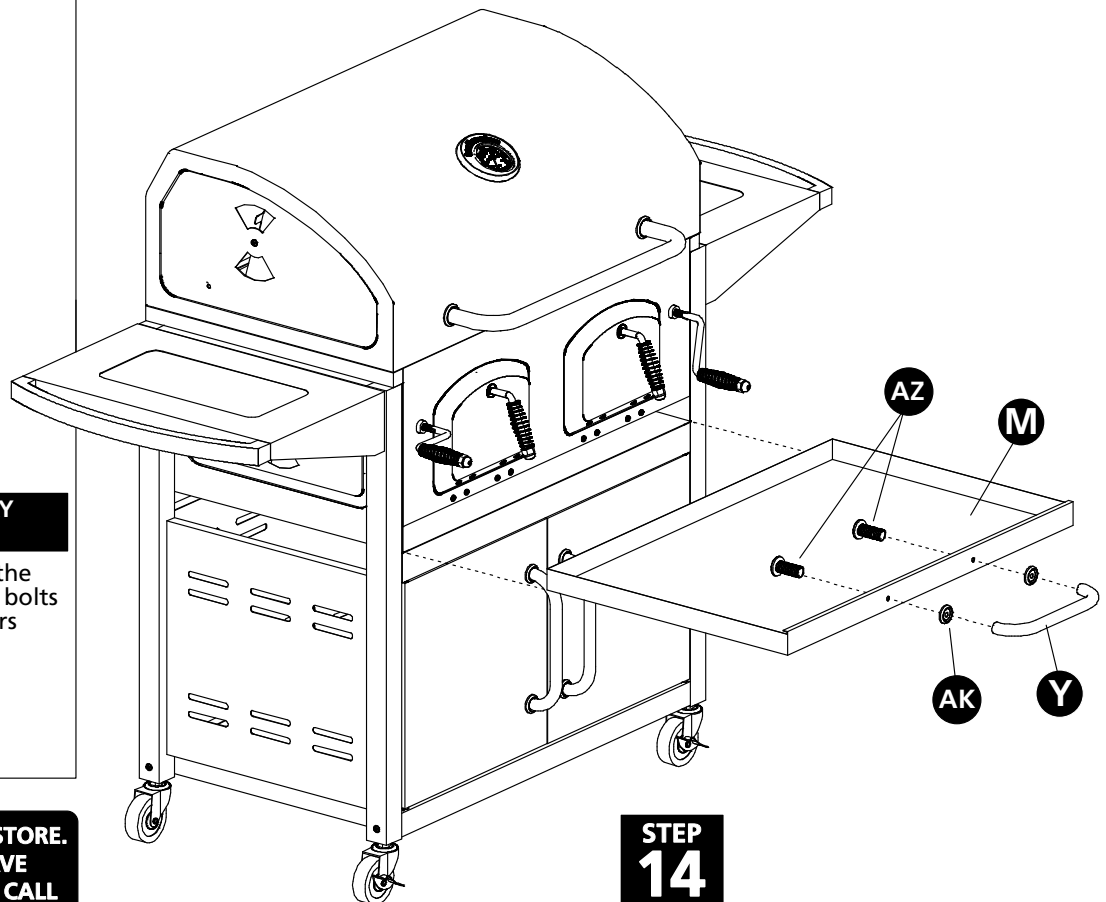

**STEP 14: ASSEMBLE THE ASH TRAY  
AND HANDLE**

Assemble the small handle [ Y ] to the ash tray [ M ] using (2) M6 x 15MM bolts [ AZ ] and (2) small finishing washers [ AK ]. Assemble as shown.

Insert the ash tray into the cooking chamber.

**STEP  
14**

**DO NOT RETURN PRODUCT TO THE STORE.  
IF YOU HAVE QUESTIONS OR HAVE  
TROUBLE WITH ASSEMBLY, PLEASE CALL  
1-877-347-4557 FOR ASSISTANCE.**

**STEP 15: INSERT THE COOKING GRATES**

Place the (2) cast iron cooking grates [ V ] on the grill as shown.

Handle the cooking grates with care as the cast iron grates can chip, crack or break if hit or struck with a sharp object. Do not drop the cast iron grates on the ground.

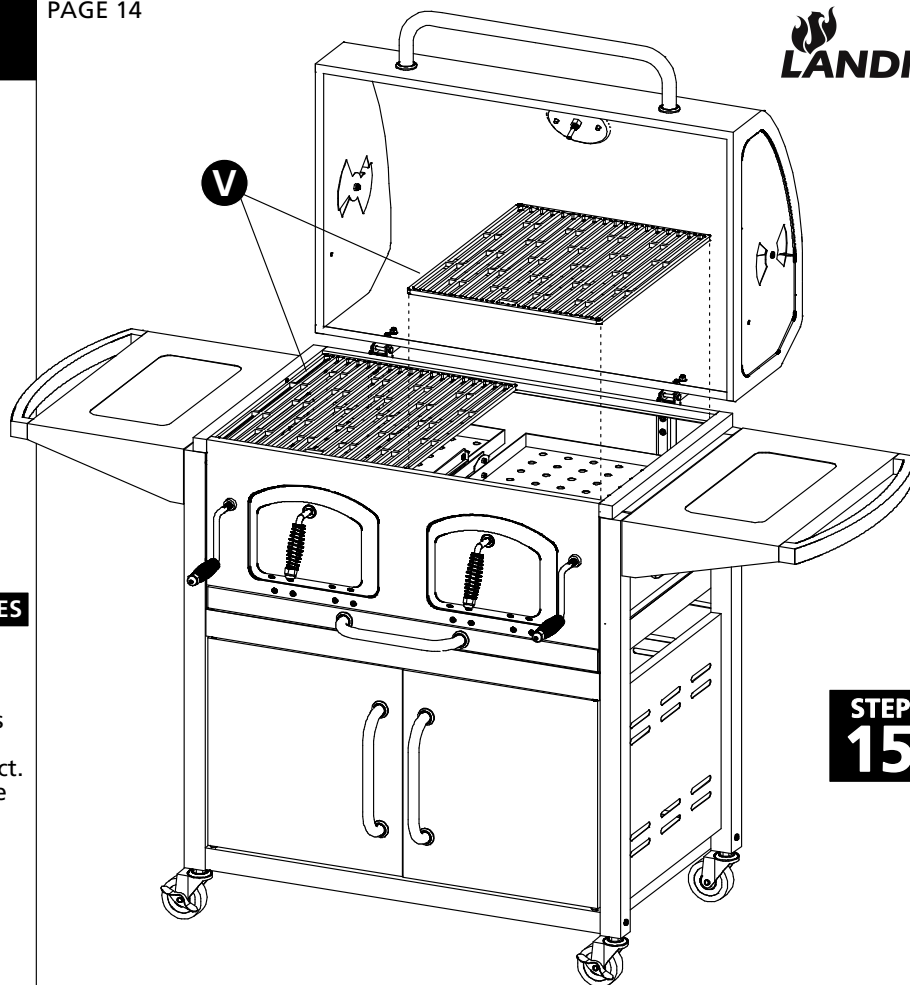

**STEP  
15**

**STEP 16: ASSEMBLE THE WARMING  
GRATE**

Assemble the warming grate [ W ] to the cooking chamber by aligning the rods and legs with holes. Assemble as shown.

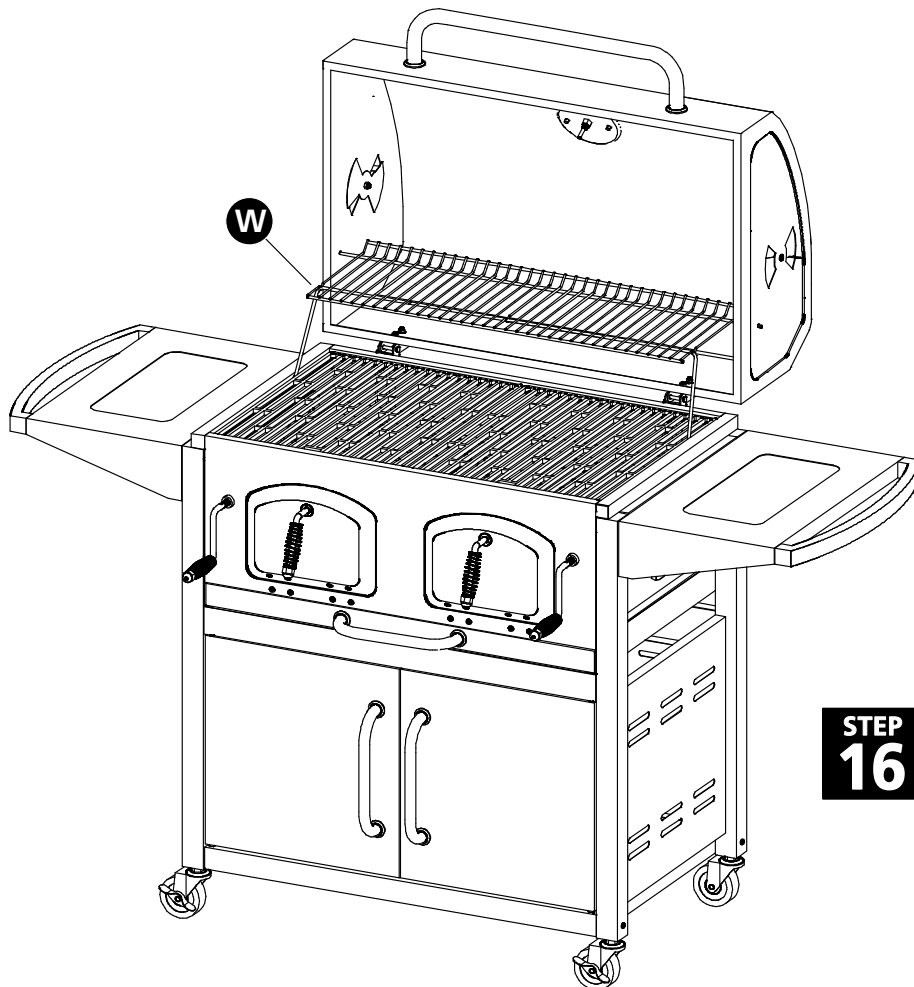

**STEP  
16**

**DO NOT RETURN PRODUCT TO THE STORE.  
IF YOU HAVE QUESTIONS OR HAVE  
TROUBLE WITH ASSEMBLY, PLEASE CALL  
1-877-347-4557 FOR ASSISTANCE.**

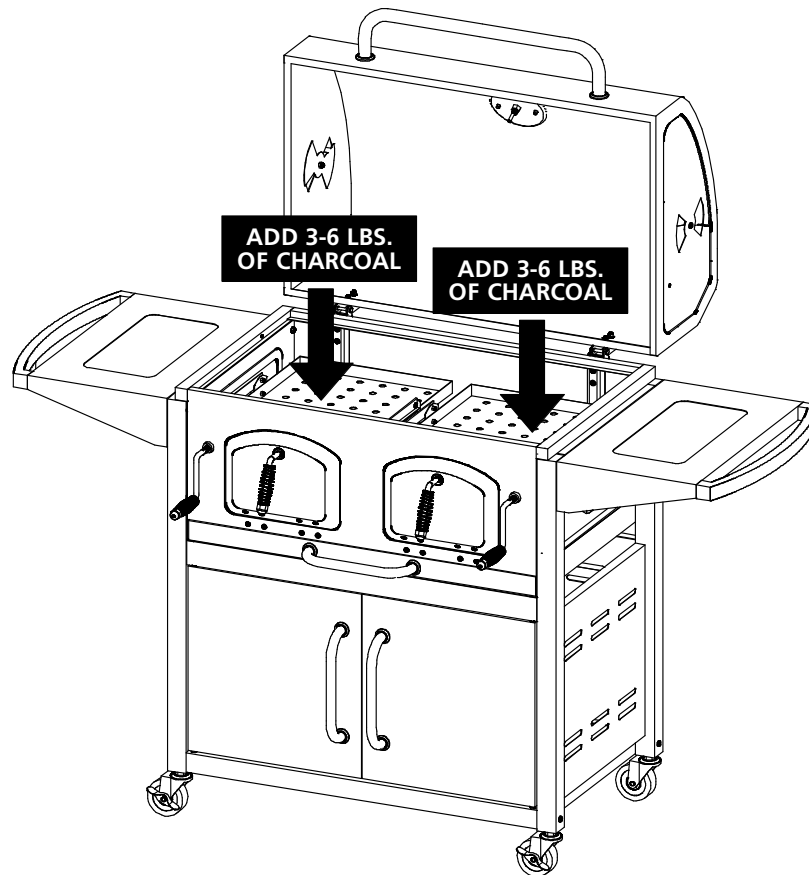

## BRAVO CHARCOAL GRILL OPERATING INSTRUCTIONS



### WARNING !

This grill becomes very hot and possibly the handles. Use caution working around the grill. Use mittens or oven gloves when opening the lid, access doors, ash tray or adjusting the vents during use.

1. Pour the desired amount (3-6 lbs.) of charcoal onto the charcoal pan(s).
2. Keep all charcoal inside the pans. Do not allow charcoal to come in contact with the sides. Pick up any loose charcoal that falls onto the ash pan.
3. Adjust all vents to full open and keep the lid open.
4. Light charcoal according to the charcoal manufacturer instructions.
5. After the flames have disappeared from the charcoal, close the lid, keep all vents full open.
6. After about 10-15 minutes, check the charcoal to see that it has ashed over (turned gray) and the initial starter odors are gone.
7. Adjust the charcoal or spread the charcoal evenly across the charcoal pan(s) if necessary.
8. The optimum cooking temperature is 300~350 degrees. The vents may need to be adjusted more open or more closed for the desired temperature. The type charcoal and the climate conditions can affect the grill temperature.
9. Carefully wipe the cooking grate surfaces with vegetable oil to keep the food from sticking.
10. Add meat and food as desired to the cooking grates. Cook food to your personal preference.
11. Add charcoal or wood as needed through the access doors.

**OPTIONAL:** If preferred, small wood chunks can be added to the charcoal at this time for flavor and smoke. Crank the charcoal pans to the lowest position away from the cooking grates. Carefully open the access door(s) and carefully add small wood chunks on top of the charcoal. The smoke will be heavy at first and after a short while will burn with less smoke. The temperature will spike when the wood is first added. As a general rule, you will need to add more wood or charcoal when the temperature drops below 250 degrees. Do not use more than 2 or 3 wood chunks at a time. **DO NOT ALLOW THE WOOD CHUNKS TO TOUCH OR COME IN CONTACT WITH ANY SIDE PANEL.** Keep wood chunks inside the charcoal pans.



The adjustable charcoal pans can be moved to within a few inches of the cooking grate allowing you to sear the meat and lock in the juices. Searing takes only a few minutes on each side. Don't allow the meat or food to burn. After searing, crank the charcoal pans back down from the top and cook the food to your personal preference.

# FOOD TEMPERATURES

If you are unsure about when food is done, use this chart as a guide for measuring properly cooked meat temperatures.

Use a high quality meat thermometer with probe to measure the meat temperature. Push probe into the thickest part of the meat to get an accurate measurement. The temperature gauge on the grill measures the air temperature of the grill cooking chamber, not the food temperature.

## Steaks & Roasts

- Medium rare . . . . .145°F
- Medium . . . . .160°F
- Well done . . . . .170°F

## Bison

- Medium rare . . . . .145°F
- Medium . . . . .160°F
- Well done . . . . .170°F

## Lamb

- Medium rare . . . . .145°F
- Medium . . . . .160°F
- Well done . . . . .170°F

## Ground Meats

- Beef, Pork . . . . .160°F
- Turkey . . . . .165°F

## Pork

- Medium . . . . .160°F
- Well done . . . . .170°F

## Poultry

- Turkey . . . . .165°F
- Chicken . . . . .165°F

**Fish** . . . . .145°F

**Egg Dishes** . . . . .160°F

If you still have questions, please see the USDA contact info below.

USDA Meat and Poultry Hotline  
1-888-674-6854  
TTY: 1-800-256-7072  
[www.IsItDoneYet.gov](http://www.IsItDoneYet.gov)

**⚠ WARNING!**  
NEVER USE GASOLINE, ALCOHOL OR VOLATILE FLUIDS TO START OR RESTART FIRES.

**⚠ WARNING!**  
HOT SURFACES DURING USE! USE MITTENS OR GLOVES ON THESE PARTS.

Congratulations on your purchase of the Bravo Premium Charcoal Grill! At Landmann USA, we strive to provide you with an easy to use, easy to assemble product. However, in the unlikely event your package should have a missing or defective part, please contact us at: customerservice@landmann-usa.com -OR- 1-877-347-4557 M-F 8-5 ET. Proof of purchase may be required. Thank you!

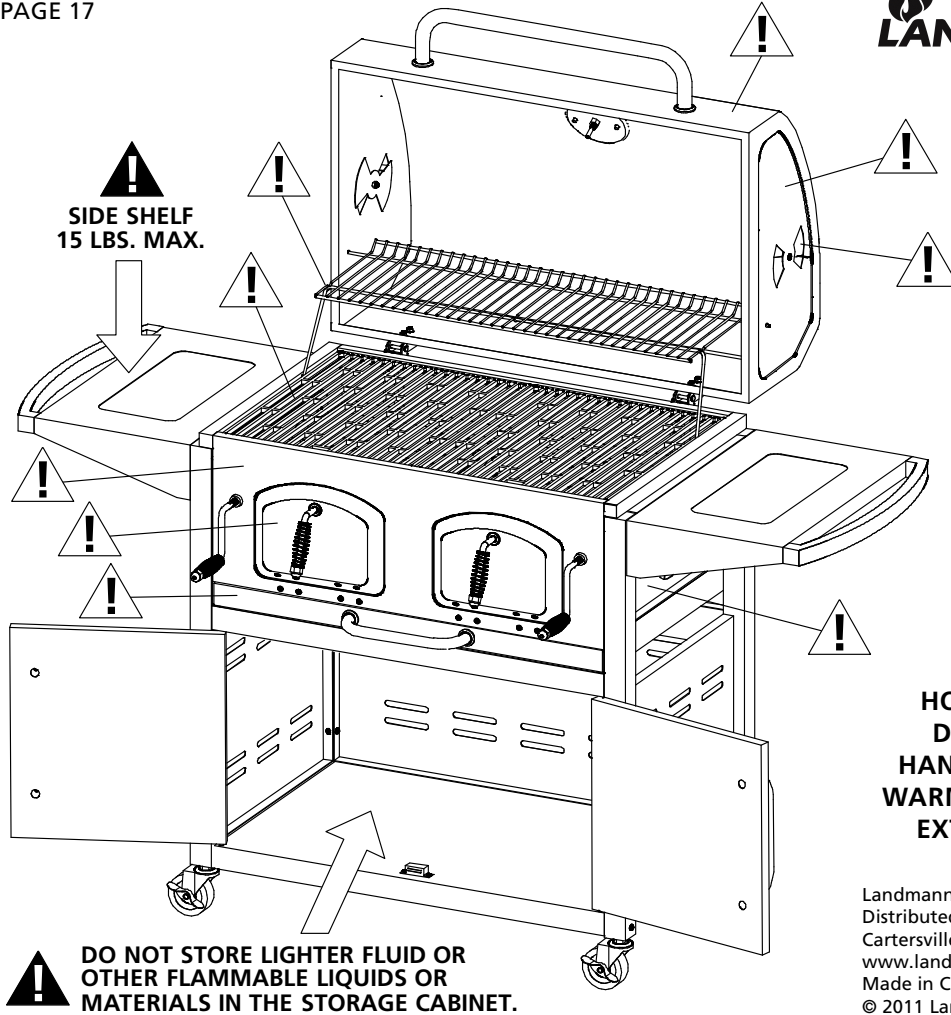

**⚠ HOT SURFACES DURING USE! HANDLES BECOME WARM TO HOT WITH EXTENDED USE.**

Landmann® Limited  
Distributed by Landmann® USA  
Cartersville, GA 30120  
www.landmann-usa.com  
Made in China  
© 2011 Landmann® USA

## BRAVO PREMIUM CHARCOAL GRILL ACCESSORIES

### ACCESSORIES FOR BRAVO

BRAVO ACCESSORIES	PRICE	QTY	EXTENDED PRICE
<p><b>COVER</b> MODEL 150120 This high quality cover keeps out the elements.</p>	\$45.99 EACH	x ( ) =	
<p><b>SHIPPING &amp; HANDLING *</b> For each cover</p>	\$18.95 EACH	x ( ) =	

**TOTAL** →  
Must include shipping & handling for each item bought.

**NOTE: THESE PRICES ARE GOOD THRU DECEMBER 31, 2012**  
\* Ships UPS ground in lower continental 48 states, excludes Hawaii, Alaska, US Virgin Islands and Puerto Rico. Please call for shipping quote into these excluded areas. NO COD's.

#### To Order:

- FOR FAX OR MAIL ORDERS:
- Determine the quantity needed for each accessory.
  - Multiply price by the quantity to get the extended price.
  - Add shipping for each item.
  - Add all lines in extended price column to get the total.
  - Fill in billing address.
  - Fill in shipping address if needed.
  - Make a photocopy of this form for your records.
  - Mail or fax the completed form to:

Landmann USA  
Attn: Accessories Dept.  
101 Old Mill Rd  
Building 300  
Cartersville, GA 30120

FAX: 770-606-8112

-OR-

FOR CALL IN ORDERS:  
Call customer service toll free at: 1-877-347-4557

-OR-

VISIT OUR ONLINE STORE:  
www.landmann-usa.com

#### Billing Address

(Matches credit or debit card information)

Name \_\_\_\_\_  
Street Address \_\_\_\_\_  
City \_\_\_\_\_  
State \_\_\_\_\_ Zip \_\_\_\_\_  
Daytime Telephone \_\_\_\_\_  
Email \_\_\_\_\_

#### Shipping Address

(If different than billing address)

Name \_\_\_\_\_  
Street Address \_\_\_\_\_  
City \_\_\_\_\_  
State \_\_\_\_\_ Zip \_\_\_\_\_  
Daytime Telephone \_\_\_\_\_

#### Payment

(Credit and debit cards accepted only)

CHARGE:  VISA  MasterCard  American Express  Discover

CARD NUMBER: \_\_\_\_\_

EXPIRATION DATE: \_\_\_\_\_

SECURITY CODE: \_\_\_\_\_



## LIMITED WARRANTY

Landmann USA ("Landmann") warrants that this product shall be free of defects in material and workmanship to the original purchaser for 90 days. This limited warranty is made exclusively to the original customer presenting proof of purchase. This warranty is limited to non-commercial residential use only. Any returned goods must be shipped prepaid. The ash tray is specifically excluded from this warranty, as cleaning and maintaining is vital to its life, lining with aluminum foil will help prolong the use of the ash tray over time.

This warranty does not cover normal wear of parts or damage resulting from any of the following: negligence, abuse, misuse, alteration, improper installation, improper maintenance or failure to perform normal maintenance, or any use contrary to operating instructions. Furthermore, Landmann does not warrant in any way the paint finish of the product or cover damage or deterioration due to any normal or severe weather conditions or to any chemical exposure. These warranties do not cover surface scratches or heat damage, which is considered to be normal wear. These warranties exclude liability for any indirect, incidental consequential damages or loss of property of any nature.

Do not return product or any parts to the store or ship to the manufacturer without written authorization.

Contact Customer Service at: 1-877-3GRILLS (1-877-347-4557) or [grills@landmann-usa.com](mailto:grills@landmann-usa.com). Any returned products or parts must be returned postage prepaid.

These warranties are limited to non-commercial residential use only.

Product repair or replacement as provided under this warranty is your exclusive remedy. Landmann shall not be liable for any incidental or consequential damages or breach of any express or implied warranty on this product or any part thereof, except to the extent prohibited by applicable law. Some states do not allow the exclusion or limitation of incidental or consequential damages, or allow limitation on how long an implied warranty lasts, therefore, the above limitation or exclusion may not apply to you. This warranty gives you specific legal rights, and you may also have other rights, which vary, from state to state.