

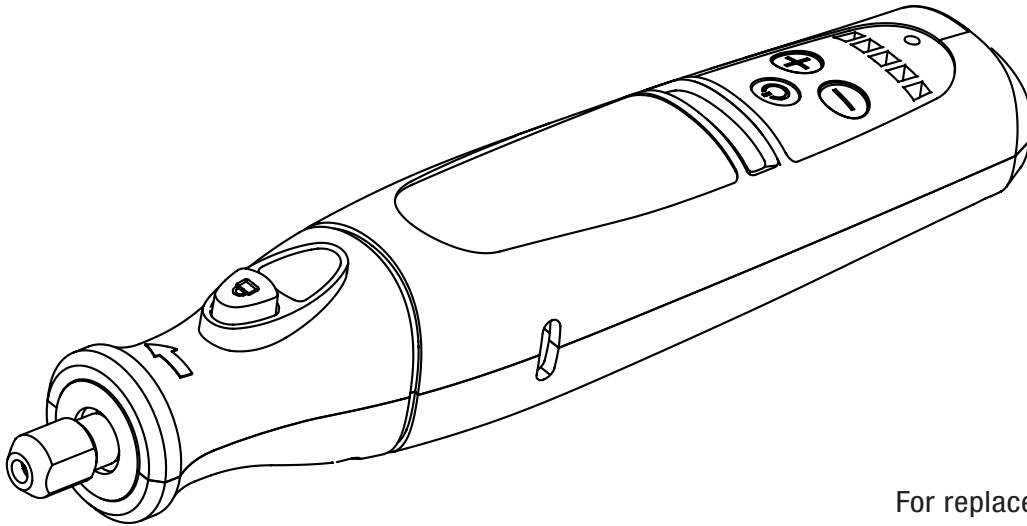

MODEL 23072

CORDLESS ROTARY TOOL



For replacement parts visit
WENPRODUCTS.COM

IMPORTANT:

Your new tool has been engineered and manufactured to WEN's highest standards for dependability, ease of operation, and operator safety. When properly cared for, this product will supply you years of rugged, trouble-free performance. Pay close attention to the rules for safe operation, warnings, and cautions. If you use your tool properly and for its intended purpose, you will enjoy years of safe, reliable service.

NEED HELP? CONTACT US!

Have product questions? Need technical support?
Please feel free to contact us at:



800-232-1195 (M-F 8am-5pm CST)



techsupport@wenproducts.com



WENPRODUCTS.COM



NOTICE: Please refer to wenproducts.com for the most up-to-date instruction manual.

TABLE OF CONTENTS

Specifications	2
Introduction	3
Rotary Tool Safety Rules	4
Safety Rules for Batteries & Chargers	8
Know Your Rotary Tool & Accessories	10
Preparation & Assembly	12
Operation	14
Maintenance	16
Warranty Statement	17
Exploded View & Parts List	18

SPECIFICATIONS

Model Number	23072
Power	DC 7.2V
No-Load Speed	5,000 to 25,000 RPM
Battery	7.2V Li-ion Battery, 900mAh
Charger (23072C)	Rated Input: AC 100-240V, 50/60Hz, 0.2A
	Rated Output: DC 9V, 0.5mA
Max Collet Capacity	1/8 in. (3.2 mm)
Product Dimensions	8.1 x 1.5 x 1.5 in. (205 x 38 x 39 mm)
Product Weight (with Battery)	9.3 oz.

Compatible Rotary Tool Accessories Kits: 150-Piece (Model 230151A), 282-Piece (Model 230282A), 320-Piece (Model 230321A), 327-Piece (Model 230327A), available for purchase at wenproducts.com.

INTRODUCTION

Thanks for purchasing the WEN Rotary Tool. We know you are excited to put your tool to work, but first, please take a moment to read through the manual. Safe operation of this tool requires that you read and understand this operator's manual and all the labels affixed to the tool. This manual provides information regarding potential safety concerns, as well as helpful assembly and operating instructions for your tool.

 **SAFETY ALERT SYMBOL:** Indicates danger, warning, or caution. The safety symbols and the explanations with them deserve your careful attention and understanding. Always follow the safety precautions to reduce the risk of fire, electric shock and personal injury. However, please note that these instructions and warnings are not substitutes for proper accident prevention measures.

NOTE: The following safety information is not meant to cover all possible conditions and situations that may occur. WEN reserves the right to change this product and specifications at any time without prior notice.

Keep this manual available to all users during the entire life of the tool and review it frequently to maximize safety for both yourself and others.

ROTARY TOOL SAFETY RULES

Safety is a combination of common sense, staying alert and knowing how your item works. SAVE THESE SAFETY INSTRUCTIONS.



WARNING: Read and understand all warnings, cautions and operating instructions before using this tool. Failure to follow all instructions listed below may result in personal injury and tool damage.

OPERATING ENVIRONMENT

1. Keep the tool away from water. Do not expose the tool to rain or wet conditions. Water entering a power tool will increase the risk of electric shock.
2. Do not operate power tools in explosive atmospheres, such as in the presence of flammable liquids, gases or dust. Power tools create sparks which may ignite the dust or fumes.
3. Keep work area clean and well lit. Cluttered or dark areas can cause accidents. Do not work on floor surfaces that are slippery with sawdust or wax.
4. Keep bystanders at a safe distance from the work area. Never allow children or pets near the tool.

PERSONAL SAFETY

1. Stay alert. Watch what you are doing and use common sense when operating a power tool. Do not use a power tool while you are tired or under the influence of drugs, alcohol or medication. A moment of inattention while operating power tools may result in serious personal injury.
2. Use personal protective equipment:
 - Always wear safety goggles at all times that comply with ANSI Z87.1.
 - Use hearing protection such as plugs or muffs during extended periods of operation.
 - Wear a face mask or dust mask to fight the dust produced by sanding operations.
3. Do not wear loose clothing, gloves, neckties, or jewelry (rings, watches, etc.) when operating the tool. Inappropriate clothing and items can get caught in moving parts and draw you in. Always wear non-slip footwear and tie back long hair.
4. Do not overreach. Keep proper footing and balance at all times.

WORKPIECE INSPECTION

1. Before operation, check the workpiece for any cracks, bumps, nails or obstructions.
2. Check the position of all electrical wiring before drilling into walls, floors or ceilings.
3. Do not cut any material that exceeds the rotary tool or the rotary tool bit's operation capacity.
4. Use clamps to secure the workpiece whenever possible to prevent wobble, damage to the workpiece, and personal injury.

ROTARY TOOL SAFETY RULES

ROTARY TOOL ACCESSORIES

1. The rotary tool accessory must have a rated speed higher than 25,000 RPM (the maximum operating speed of your rotary tool), otherwise there is a risk of injury.
2. The spindle diameter of the accessory bit must match the size of the collet. The included collet size is 1/8 inch (3.2 mm); collets of other sizes may be purchased separately depending on the spindle diameter of the accessory.
3. Inspect the accessories for any cracks, excess wear, or bent shanks. Do not use damaged accessories.

ROTARY TOOL OPERATION

1. Do not force the tool to do a job for which it was not designed. Use the correct power tool and accessories and follow the instructions for your application to prevent hazardous situations.
2. Before operation, check the tool for any damage or missing parts. Check for misalignment of moving parts, jamming, breakage, improper mounting, or any other conditions that may affect the tool's operation. Do not use the tool if the power switch is faulty, the plug or cable is damaged, or the tool produces sparks or smoke. Any part that is damaged should be properly repaired or replaced before use.
3. Avoid accidental start-ups. Make sure the tool is OFF before installing batteries, making adjustments, picking up or carrying the tool.
4. Remove adjustment tools. Always make sure all adjustment tools or wrenches are removed from the tool before turning on the power tool.
5. Set the suitable speed for your operation, workpiece and accessory. Use slow speeds for some plastics and precious metals to prevent damaging the material.
6. Before turning on the rotary tool, ensure that it is completely clear of the workpiece. Let the tool reach full speed before making contact with the workpiece.
7. When operating the rotary tool:
 - Do not apply excessive pressure to the tool or attempt to make an excessive depth of cut. Overstressing the tool may cause kickback and damage the tool and accessories.
 - Use special care when working corners, sharp edges etc. Avoid bouncing and snagging the accessory.
 - Never touch any moving parts of the tool by hand.
 - Never press in the spindle lock button when the rotary tool is running.
8. Never leave a running tool unattended. Do not leave the tool until it has come to a complete stop.
9. Clear the tool from the workpiece before switching off the tool. Wait for the rotary bit to come to a complete stop before setting the tool down. Do not touch the accessory attachment immediately after operation, as it may be very hot. Allow time for the accessory to cool and calm down before removing it.

ROTARY TOOL SAFETY RULES

ROTARY TOOL MAINTENANCE

1. Battery tools do not need to be plugged into an electrical outlet, therefore they are always ready to operate. Beware of the possible hazards when not using your battery tool or when changing accessories. Following this rule will reduce the risk of electric shock, fire or personal injury.
2. Always turn off the machine before making adjustments or changing attachments. Such preventive safety measures reduce the risk of starting the power tool accidentally. Do not remove the attachment from the tool until it has completely stopped rotating.
3. Maintain power tools properly. Safely store power tools out of the reach of children. Always keep tools clean and in good working order.
4. Servicing of the tool should only be performed by an authorized service technician, using identical replacement parts.

REDUCING KICKBACK

Kickback is a sudden reaction to a pinched or snagged rotating wheel, backing pad, brush or any other accessory. Pinching or snagging causes rapid stalling of the rotating accessory which in turn causes the uncontrolled power tool to be jump toward or away from the operator, depending on direction of the wheel's movement at the point of pinching.

Take proper safety prevention methods to reduce the risk of kickback:

1. Maintain a firm grip on the power tool and position your body and arm to allow you to resist kickback forces. Always use the auxiliary handle for maximum control over kickback or torque reaction during start-up. The operator can control torque reactions or kickback forces, if proper precautions are taken.
2. Never place your hand near the rotating accessory. Accessories may kick back over your hand.
3. Do not position your body in the area where power tool will move if kickback occurs. Kickback will propel the tool in direction opposite to the wheel's movement at the point of snagging.
4. Use special care when working corners, sharp edges etc. Avoid bouncing and snagging the accessory. Corners, sharp edges or bouncing have a tendency to snag the rotating accessory and cause loss of control or kickback.

ROTARY TOOL SAFETY RULES

VIBRATION SAFETY

This tool vibrates during use. Repeated or long-term exposure to vibration may cause temporary or permanent physical injury, particularly to the hands, arms and shoulders. To reduce the risk of any vibration-related injury:

1. First be examined by a doctor and then have regular medical check-ups to ensure medical problems are not being caused or worsened from use. Pregnant women or people who have impaired blood circulation to the hand, past hand injuries, nervous system disorders, diabetes, or Raynaud's disease should not use this tool.
2. If you feel any symptoms related to vibration (such as tingling, numbness, and white or blue fingers), seek medical advice as soon as possible.
3. Do not smoke during use. Nicotine reduces the blood supply to the hands and fingers, increasing the risk of vibration-related injury.
4. Wear suitable work gloves to reduce the effects of vibration. Hold the tool firmly enough to keep safe control of it, but NOT too tightly. The risk associated with vibration is increased when the gripping force is high. Let the tool do the work.
5. Take vibration-free breaks during each day of work.

CALIFORNIA PROPOSITION 65 WARNING

Some dust created by power sanding, sawing, grinding, drilling, and other construction activities may contain chemicals, including lead and wood dust, known to the State of California to cause cancer, birth defects, or other reproductive harm. Wash hands after handling. Some examples of these chemicals are:

- Lead from lead-based paints.
- Crystalline silica from bricks, cement, and other masonry products.
- Arsenic and chromium from chemically treated lumber.

Your risk from these exposures varies depending on how often you do this type of work. To reduce your exposure to these chemicals, work in a well-ventilated area with approved safety equipment such as dust masks

These safety instructions can't possibly warn of every scenario that may arise with this tool, so always make sure to stay alert and use common sense during operation.

SAFETY RULES FOR BATTERIES & CHARGERS

BATTERY & CHARGER SAFETY

1. Only use the tool with the battery pack specified by the manufacturer. The lithium-ion battery is pre-installed inside the tool. Replacement of batteries must be performed **ONLY** by a qualified service technician using identical replacement parts.
2. Only recharge the battery with the charger specified by the manufacturer. A charger that is suitable for one type of battery pack may create undesirable risks, including but not limited to fire and death, when used with another battery pack. Do not use the supplied battery charger to charge other cordless tools.
3. Do not expose the battery pack or the charger to damp environments such as water or rain.
4. Do not keep battery tool or charger near fire, sources of heat, or use in direct sunlight.
5. Do not operate the charger or the battery if it has received a sharp blow, either from being dropped or damaged. Take it to a qualified service technician before attempting to use.
6. Do not attempt to disassemble the charger or the battery pack. Take them to a qualified service technician when service or repairs are required. Incorrect assembly may result in electric shock or fire.

BATTERY-SPECIFIC SAFETY (a lithium-ion battery pack is pre-installed inside the tool)

1. Do not short the battery pack. Do not touch the terminals with any conductive material. Avoid storing the battery pack in a container with other metal objects such as nails, coins, etc. Always protect the battery terminals when the battery pack is not in use. Shorting the battery terminals together may cause burns or fire.
2. Do not use batteries that have suffered curvature or deformation during the charging process or those that exhibit other atypical symptoms (gassing, hissing, cracking, etc.)
3. Do not incinerate the battery pack. The battery pack can explode in a fire and pose a threat to anyone in the immediate area.
4. Under abusive conditions, liquid may be ejected from the battery. Avoid contact with this liquid like you would a fire or an ex-lover. If contact accidentally occurs, flush the contact area with water. If the liquid contacts your eyes, flush with water for 10 minutes and then seek medical help. Liquid ejected from the battery may cause irritation or burns.
5. Never use or charge a battery pack if you suspect that it has been more than 12 months since the last time it was charged. There is a high probability that the battery pack has already suffered dangerous damage (exhaustive discharge).
6. If the tool operating time has become excessively shorter, stop operating the tool immediately. The battery may have been damaged, and could possibly result in overheating, burning, or even an explosion.
7. When disposing of the battery, remove the battery pack from the tool housing and cover the battery connections with heavy-duty adhesive tape to prevent short circuit and energy discharge.

SAFETY RULES FOR BATTERIES & CHARGERS

CHARGER-SPECIFIC SAFETY

1. Protect the battery charger and its cord from damage. Keep the charger and its cord away from heat, oil and sharp edges. Do not operate the charger with a damaged cord or plug.
2. Electrical plugs must match the outlet. Never modify the plug in any way. Do not use any adapter plugs with grounded appliances. Unmodified plugs and matching outlets will reduce the risk of electric shock.
3. Do not attempt to connect the charger to a step-up transformer, an engine generator or a DC power receptacle.
4. To reduce the risk of electric shock, unplug the charger from the outlet before attempting any maintenance or cleaning.

CHARGING THE BATTERY TOOL

1. Charge the battery tool fully before using it for the first time.
2. During periods of heavy use, the battery pack will become warm. Allow the tool to cool to room temperature recharging.
3. Place the charger on a flat non-flammable surface and away from flammable materials when re-charging the tool.
4. Do not charge the tool inside a box or container of any kind. The tool and charger must be placed in a well-ventilated area during charging. Do not allow anything to cover or clog the charging vents.
5. Do not charge the tool when the ambient temperature is below 50 degrees F (10 degrees C) or above 104 degrees F (40 degrees C).
6. The battery takes about 3 hours to charge from low power to full power. After 3 hours of charging, the red indicator LED will turn off, and the machine is ready for use. Do not overcharge batteries. Do not leave the tool on the charger for days on end.

BATTERY & CHARGER STORAGE

1. Disconnect the charger from the power source when not in use. This will reduce the risk of electric shock or damage to the charger if metal pieces should fall into the opening. It also will help prevent damage to the charger during a power surge.
2. Keep the tool and battery charger out of the reach of children.
3. Store the tool in a location where temperatures will not exceed 122 degrees F (50 degrees C). This will help prevent serious damage to the battery cells.
4. Recycle used battery tool and charger at your local recycling facility.

KNOW YOUR ROTARY TOOL & ACCESSORIES

Carefully unpack the tool and accessories. Check all components and compare against the list below. If any part is damaged or missing, please contact our customer service at (800) 232-1195, M-F 8-5 CST or email techsupport@wenproducts.com.

ROTARY TOOL ASSEMBLY

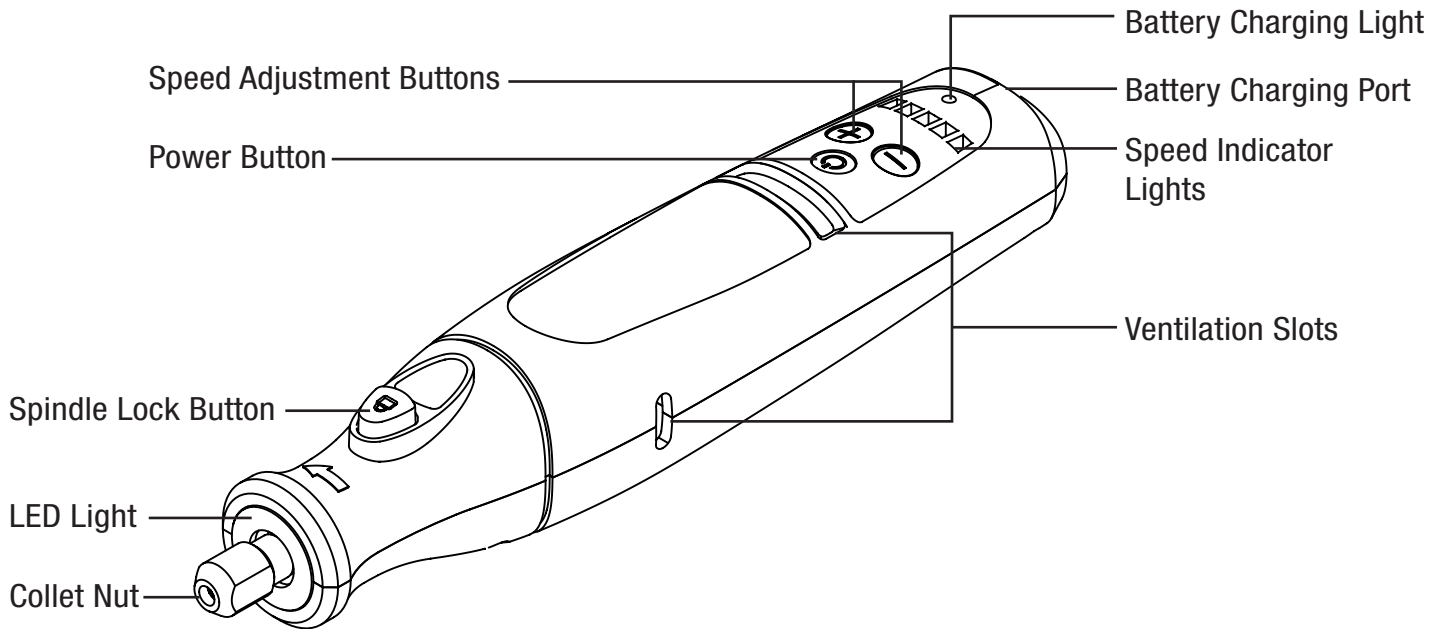

ROTARY TOOL ACCESSORIES

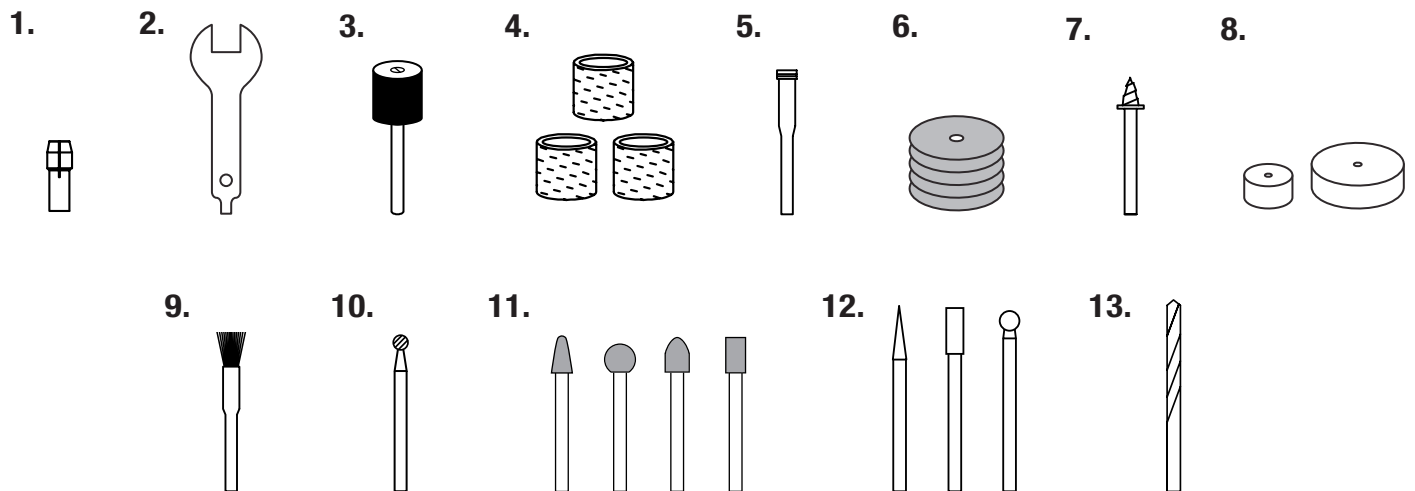

- 1. 1pc Collet, Ø1/8" (3.2 mm)
- 2. 1pc Wrench
- 3. 1pc Sanding Drum Mandrel
- 4. 3pcs Sanding Band

- 5. 1pc Disc Mandrel
- 6. 5pcs Cutting Disc
- 7. 1pc Screw Mandrel
- 8. 2pcs Felt Polishing Wheel

- 9. 1pc Nylon Wire Brush
- 10. 1pc HSS Cutter Bit
- 11. 4pcs Grinding Stone Bit
- 12. 3pcs Diamond Coated Bit
- 13. 1pc HSS Drill Bit

KNOW YOUR ROTARY TOOL & ACCESSORIES

No.	Accessory	Explanation & Applications
1	Collet (Ø1/8)	Installs onto the tool's spindle for holding a rotary tool bit in place. Your tool comes with one Ø1/8" collet. The shank diameter of the rotary tool bit must match the size of the collet.
2	2-in-1 Wrench	<ul style="list-style-type: none"> • Use the front of the wrench for loosening/tightening the collet nut to remove/install rotary tool bits or to change collets. • Use the back of the wrench for adjusting the screw on the Sanding Drum Mandrel and Disc Mandrel (see page 12).
3	Sanding Drum Mandrel (Ø1/8")	A mandrel with a cylinder-shaped rubber tip for attaching sanding bands. Can be expanded or retracted using the back of the Wrench (see page 12).
4	Sanding Band	Slides over the top of the No. 3 sanding drum mandrel to sand and smooth around surfaces and inside curves. NOTE: Replace the sanding bands when the grits are worn down.
5	Disc Mandrel (Ø1/8")	A mandrel with a threaded head and slotted cap for attaching wheel/disc accessories (see page 12).
6	Cutting Disc	Thin disc used for cutting or slicing work on metal, wood and ceramics. Cut off bolt ends or make slots in stripped screws. Only cut along the wheel's edge; DO NOT use for sanding or cutting curves. Attach to No. 5 Disc Mandrel (see page 12).
7	Felt Accessory Mandrel (Ø1/8")	A mandrel with a screw head for attaching felt polishing accessories (see page 12).
8	Felt Polishing Wheel	Screws onto the top of the screw mandrel to clean, polish and buff metal, wood and plastics to a smooth and bright finish. Do not use at speeds higher than 15,000 RPM. Attach to No. 7 Screw Mandrel (see page 12).
9	Nylon Wire Brush (Ø1/8")	For general cleaning and polishing purposes. NOTE: Excessive pressure can damage the wires. Operate with light pressure and let the tips of the wire brush do the work.
10	HSS Cutter Bit (Ø1/8")	Use for edge cutting, carving and creating slots and holes in plastics, wood and metals.
11	Grinding Stone Bit (Ø1/8")	Use for various grinding applications including sharpening blades and tools, removing flash from metal castings, deburring metal after cutting, smoothing welded joints, grinding off rivets and removing rust.
12	Diamond Coated Bit (Ø1/8")	For cutting and engraving in wood, plastics, and soft metals such as aluminum, copper, and brass.
13	HSS Drill Bit (Ø1/8")	Drills into materials such as metal, hardwood, and plastics.

Compatible Rotary Tool Accessories Kits: 150-Piece (Model 230151A), 282-Piece (Model 230282A), 320-Piece (Model 230321A), 327-Piece (Model 230327A), available for purchase at [wenproducts.com](http://www.wenproducts.com).

PREPARATION & ASSEMBLY

⚠ WARNING: To avoid injuries from accidental startups, always ensure that the tool is turned OFF before making adjustments or changing accessories.

INSTALLING SANDING BANDS (FIG. 1)

1. Loosen the flat-head screw on the top of the sanding drum using the back of the included 2-in-1 wrench.
2. Slide the sanding band onto the sanding drum.
3. Secure the sanding drum in place by tightening the screw. Make sure the sanding drum is sufficiently expanded so that the sanding band is secured in place.

NOTE: If the sanding band is loose on the drum, it may fly off during operation and cause injuries.

INSTALLING WHEEL/DISC ACCESSORIES (FIG. 2)

1. Loosen and remove the screw cap at the top of the mandrel using the back of the included 2-in-1 wrench
2. Remove the top red ring from the screw and slide the disc accessory onto the screw, above the bottom red ring.
3. Slide the top red ring above the disc accessory, so that there is one red ring on each side of the disc.
4. Reattach and tighten the screw cap onto the mandrel to secure the accessory in place.

INSTALLING FELT ACCESSORIES (FIG. 3)

Thread the felt polishing accessory straight down onto the tip of the screw mandrel. The accessory must be threaded all the way down to touch the collar of the screw mandrel.

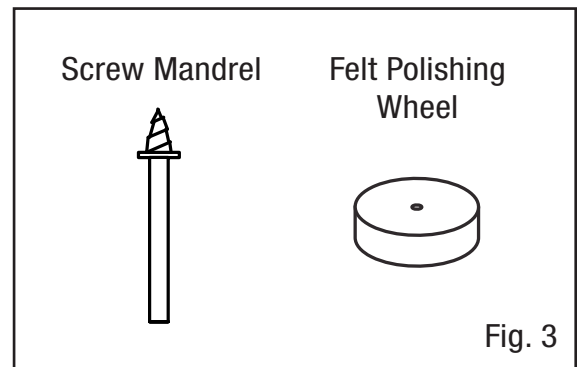
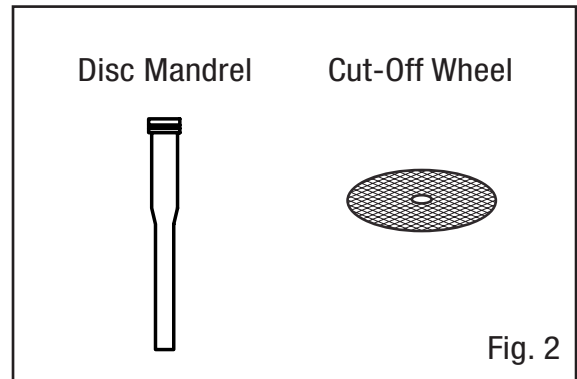
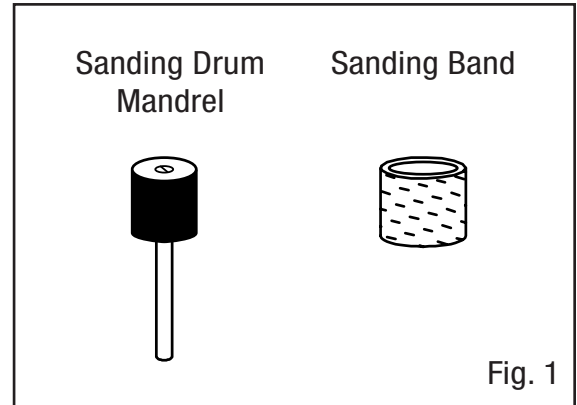

PREPARATION & ASSEMBLY

CHARGING THE TOOL (FIG. 4)

THE BATTERY TOOL MUST BE CHARGED BEFORE FIRST USE. A battery pack that has never been charged, or has not been used for an extended period of time must be charged completely before using.

NOTE: The battery pack requires approximately 3 to 5 complete charging and draining cycles before it can reach its full potential.

To charge the tool:

1. Charge your tool in a well-ventilated area and away from any flammable materials. Connect the power plug of the charger to a matching wall receptacle (AC 100-240V, 50/60Hz). Insert the other end of the charger into the charging port on the back of the rotary tool (Fig. 4 - 1).

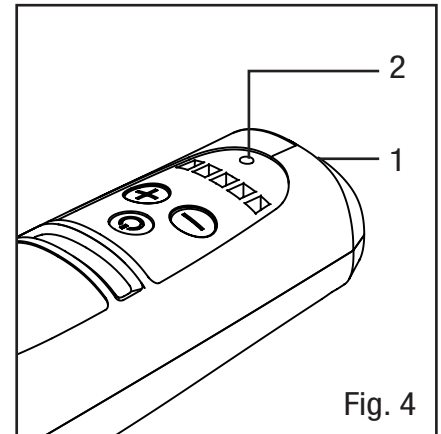

Fig. 4

2. The red battery charging light (Fig. 4 - 2) on the tool's control panel will turn red to show that the tool is charging. Charge for 2-3 hours, or until indicator light turns yellow, and your tool is ready for use.

3. Unplug the charger from the tool and store it inside the carrying case. Do not overcharge batteries.

WARNING: Do not use the tool while charging!

INSTALLING ROTARY TOOL BITS (FIG. 5)

1. Make sure the tool is OFF.

2. Hold down the spindle lock button and rotate the collet nut until the spindle lock engages.

3. Using the included wrench, loosen and remove the collet nut by turning it counterclockwise. Release the spindle lock button.

4. One 1/8" collet is pre-installed inside the tool. The shank of the rotary tool bit must match the collet size. Fully insert the suitable rotary bit into the spindle hole through the collet nut and collet.

5. Press down the spindle lock button and fully tighten the collet nut using the included wrench. Pull on the rotary tool bit to check that it is firmly secured inside the tool.

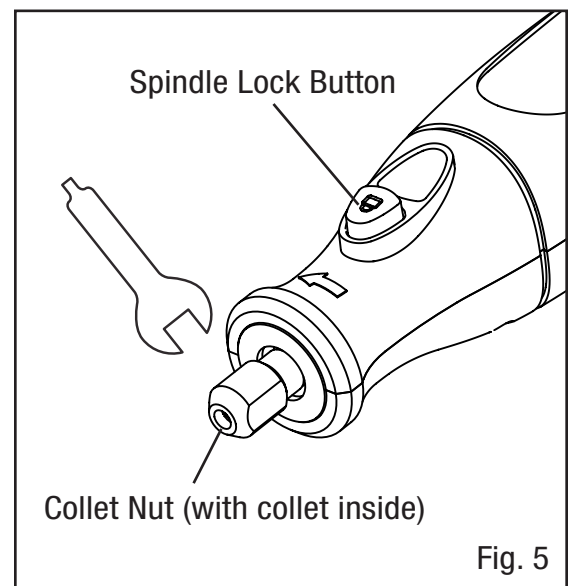

Fig. 5

WARNING: Check to make sure that all accessories are assembled correctly and securely on the rotary tool. Do not use if any accessory or part is loose or damaged.

OPERATION

⚠ WARNING: Read and thoroughly understand all instructions and safety information before operating this rotary tool. Failure to do so may cause personal injuries.

⚠ WARNING: Always wear ANSI Z87.1-approved safety glasses, safety gloves and suitable work clothing. Do not wear jewelry or other loose clothing which could get caught in moving parts. Hold the tool away from your face and body in case parts and chips fly out unexpectedly during operation.

TURNING THE TOOL ON/OFF (FIG. 6)

- To turn the tool ON, press and release the power button (Fig. 6 - 1). The tool will start operating at a speed of 5,000 RPM and the front LED light will illuminate. You can adjust the operating speed by following the instructions in the section "SETTING THE OPERATING SPEED".
- To turn the tool OFF, press and release the power button.

If the power button fails to work, you can also turn off the tool by pressing the minus (-) speed button down to the lowest speed setting, and then holding down the minus button for 6 seconds.

SETTING THE OPERATING SPEED (FIG. 6)

The operating speed of your rotary tool may be adjusted by pressing on the plus (+) or (-) minus buttons (Fig. 6 - 2) located on the control panel.

Every time the tool is turned on, the operating speed will start at 5000 RPM. With each press of the speed adjustment button, the speed will increment or decrement by 5,000 RPM, from a minimum of 5,000 RPM to a maximum of 25,000 RPM. The LED speed indicator lights (Fig. 6 - 3) below the buttons will illuminate to show the chosen speed.

Make sure to use the suitable speed for your workpiece, rotary tool bit, and the task at hand. As a general rule, larger rotary attachments should be used at a lower speed.

- Difficult jobs (drilling, engraving glass, cutting metal, etc.) are generally performed more efficiently at higher RPMs.
- Delicate polishing, or operation with plastics and low-melting-point materials require slower RPMs.

The best way to determine the suitable speed is to test on a scrap piece of similar material, observe the results, and adjust the speed accordingly.

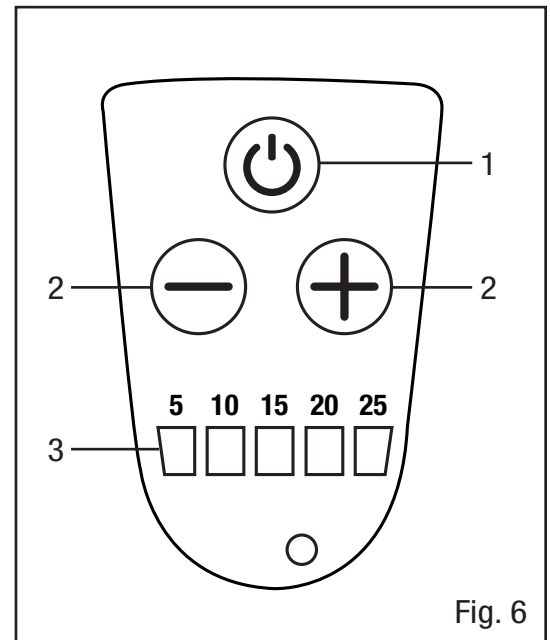

Fig. 6

OPERATION

OPERATION

1. Inspect the rotary tool and accessories for any damage before use. Immediately discard any accessories with bent shafts or any other damage. Make sure that the ventilation slots on the tool are not obstructed, otherwise the motor may overheat.

2. Turn ON the tool and adjust to the desired speed. Slowly lower the accessory bit onto the workpiece and guide the tool with light, even pressure.

NOTE: Best results are achieved by an even speed and pressure. Do not exert excessive pressure on your tool as it may damage your workpiece and the accessory bit. Let the tool do the work. For better results, you can make several progressive passes until the desired cutting depth or finish is achieved.

3. When the operation is complete, lift the tool away from the workpiece and turn it OFF. Do not touch the rotary accessory or workpiece immediately after operation as they can be very hot. Follow the instructions on the next page for properly maintaining your tool and accessories.

STALL PROTECTION

This tool has a built-in stall protection feature to protect the motor and battery in the event of a stall. If the tool is stalled for too long or the accessory is bind in the workpiece, especially at high speeds, the tool will automatically turn off.

When this happens, simply take the tool out of the workpiece, press the power button to turn it OFF and wait for 3 seconds. Then you can turn the tool back on to continue operation.

LOW BATTERY-POWER PROTECTION

When the battery is almost fully drained, the tool may shut down automatically more frequently than normal to indicate low power. If this happens, it is time to recharge the battery.



WARNING: Be alert for batteries that are nearing their end of life. If you notice decreased tool performance or significantly shorter running time between charges, the battery may have reach the end of its lifetime. Contact our customer service at (800) 232-1195, M-F 8-5 CST or email techsupport@wenproducts.com for support with battery replacement.

MAINTENANCE

 **WARNING:** To prevent personal injuries, always turn OFF the tool before cleaning, inspecting or performing maintenance.

IMPORTANT: Servicing of the tool requires extreme care and knowledge and should be performed ONLY by a qualified service technician using identical replacement parts.

CLEANING & INSPECTION

1. After each use, clean the tool and accessories using a clean cloth or a soft brush. The tool can be best cleaned using low pressure compressed dry air. Wear safety goggles when cleaning tools with compressed air. Ventilation openings and switch must be kept clean and free of any foreign objects or dust. Do not attempt to clean the tool by inserting pointed objects through the openings.

CAUTION: Most plastics are susceptible to damage from various types of commercial solvents. Do not use any solvents or cleaning products that could damage the plastic parts. Some of these include but are not limited to: gasoline, carbon tetrachloride, chlorinated cleaning solvents, and household detergents that contain ammonia.

2. Check the tool and accessories for any damage. Remove and dispose of damaged accessories.

STORAGE

Store the battery tool and charger inside the included carrying case, in a clean and dry place away from the reach of children. To help prevent damage to the battery cells, store the tool and battery pack in a location where temperatures will not exceed 122 degrees F (50 degrees C).

BATTERY PACK REPLACEMENT

Batteries should only be replaced by an authorized service technician using the identical replacement battery (Part No. 23072-013), available for purchase at wenproducts.com). DO NOT attempt to replace the battery by yourself. DO NOT use any other replacement batteries, as serious tool failure and personal injuries may result.

BATTERY TOOL DISPOSAL

Do not dispose of used battery tools with your household waste. This tool contains lithium-ion batteries and electrical or electronic components that should be recycled. Please take this product to your local recycling facility for responsible disposal to minimize its environmental impact.

WARRANTY STATEMENT

WEN Products is committed to building tools that are dependable for years. Our warranties are consistent with this commitment and our dedication to quality.

LIMITED WARRANTY OF WEN CONSUMER POWER TOOLS PRODUCTS FOR HOME USE

GREAT LAKES TECHNOLOGIES, LLC (“Seller”) warrants to the original purchaser only, that all WEN consumer power tools will be free from defects in material or workmanship for a period of two (2) years from date of purchase. Ninety days for all WEN products if the tool is used for professional or commercial use.

SELLER’S SOLE OBLIGATION AND YOUR EXCLUSIVE REMEDY under this Limited Warranty and, to the extent permitted by law, any warranty or condition implied by law, shall be the repair or replacement of parts, without charge, which are defective in material or workmanship and which have not been misused, carelessly handled, or misrepaired by persons other than Seller or Authorized Service Center. To make a claim under this Limited Warranty, you must make sure to keep a copy of your proof of purchase that clearly defines the Date of Purchase (month and year) and the Place of Purchase. Place of purchase must be a direct vendor of Great Lakes Technologies, LLC. Third party vendors such as garage sales, pawn shops, resale shops, or any other secondhand merchant void the warranty included with this product. Contact techsupport@wenproducts.com or 1-800-232-1195 to make arrangements for repairs and transportation.

When returning a product for warranty service, the shipping charges must be prepaid by the purchaser. The product must be shipped in its original container (or an equivalent), properly packed to withstand the hazards of shipment. The product must be fully insured with a copy of the warranty card and/or the proof of purchase enclosed. There must also be a description of the problem in order to help our repairs department diagnose and fix the issue. Repairs will be made and the product will be returned and shipped back to the purchaser at no charge.

THIS LIMITED WARRANTY DOES NOT APPLY TO ACCESSORY ITEMS THAT WEAR OUT FROM REGULAR USAGE OVER TIME INCLUDING BELTS, BRUSHES, BLADES, ETC. ANY IMPLIED WARRANTIES SHALL BE LIMITED IN DURATION TO TWO (2) YEARS FROM DATE OF PURCHASE. SOME STATES IN THE U.S., SOME CANADIAN PROVINCES DO NOT ALLOW LIMITATIONS ON HOW LONG AN IMPLIED WARRANTY LASTS, SO THE ABOVE LIMITATION MAY NOT APPLY TO YOU.

IN NO EVENT SHALL SELLER BE LIABLE FOR ANY INCIDENTAL OR CONSEQUENTIAL DAMAGES (INCLUDING BUT NOT LIMITED TO LIABILITY FOR LOSS OF PROFITS) ARISING FROM THE SALE OR USE OF THIS PRODUCT. SOME STATES IN THE U.S. AND SOME CANADIAN PROVINCES DO NOT ALLOW THE EXCLUSION OR LIMITATION OF INCIDENTAL OR CONSEQUENTIAL DAMAGES, SO THE ABOVE LIMITATION OR EXCLUSION MAY NOT APPLY TO YOU.

THIS LIMITED WARRANTY GIVES YOU SPECIFIC LEGAL RIGHTS, AND YOU MAY ALSO HAVE OTHER RIGHTS WHICH VARY FROM STATE TO STATE IN THE U.S., PROVINCE TO PROVINCE IN CANADA AND FROM COUNTRY TO COUNTRY.

THIS LIMITED WARRANTY APPLIES ONLY TO PORTABLE ELECTRIC TOOLS, BENCH POWER TOOLS, OUTDOOR POWER EQUIPMENT AND PNEUMATIC TOOLS SOLD WITHIN THE UNITED STATES OF AMERICA, CANADA AND THE COMMONWEALTH OF PUERTO RICO. FOR WARRANTY COVERAGE WITHIN OTHER COUNTRIES, CONTACT THE WEN CUSTOMER SUPPORT LINE.

EXPLODED VIEW & PARTS LIST

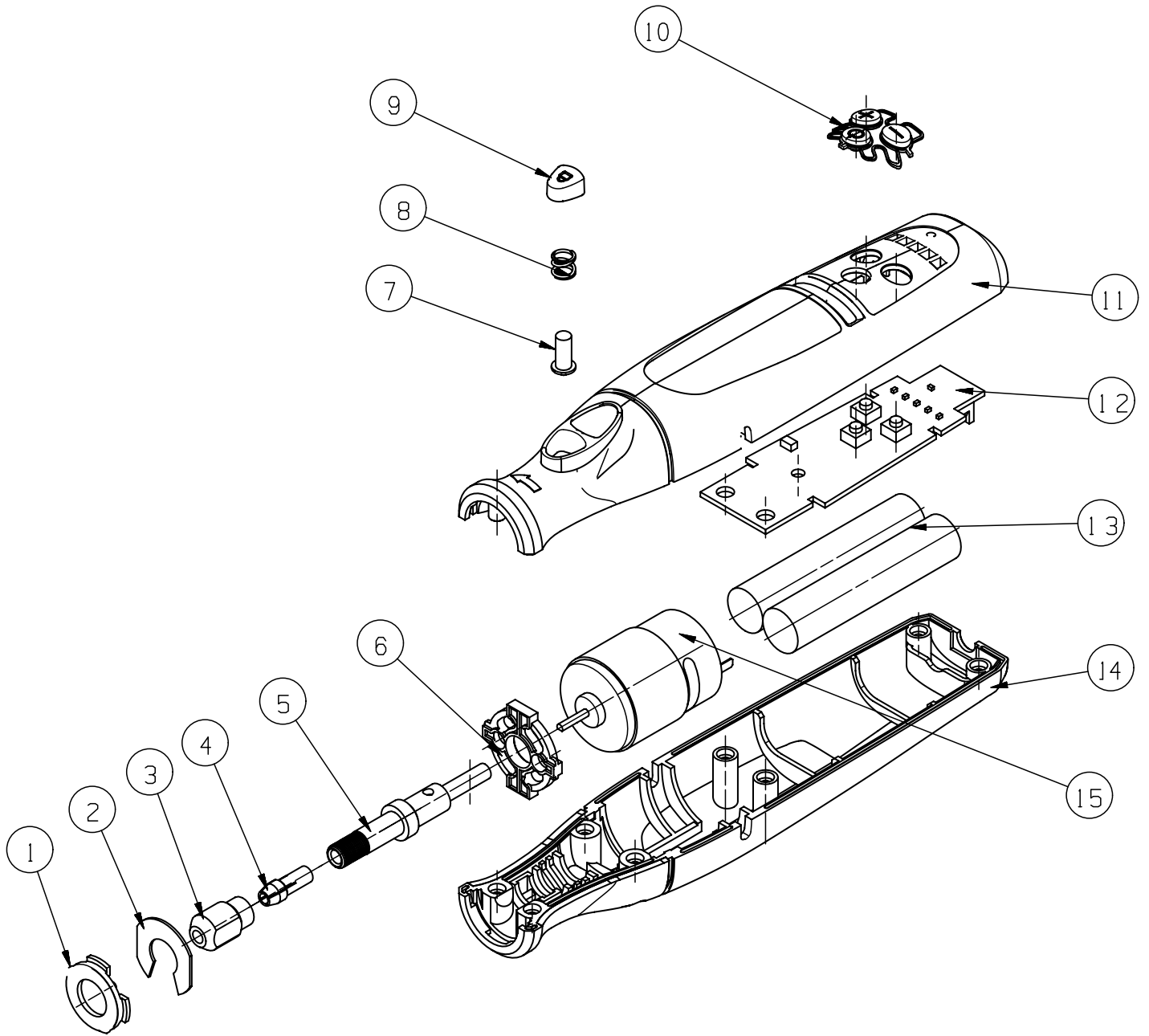

EXPLODED VIEW & PARTS LIST

No.	Part No.	Description	Qty.
1	23072-001	Cover	1
2	23072-002	LED Light	1
3	23072-003	Collet Nut	1
4	23072-004	Collet, 1/8" (3.2 mm)	1
5	23072-005	Spindle Assembly	1
6	23072-006	Motor Bracket	1
7	23072-007	Spindle Lock	1
8	23072-008	Spindle Lock Spring	1
9	23072-009	Spindle Lock Button	1
10	23072-010	Switch Assembly	1
11	23072-011	Front Housing	1
12	23072-012	Circuit Board	1
13	23072-013	Lithium-ion Battery Pack	1
14	23072-014	Back Housing	1
15	23072-015	Motor	1
16	23072C	Charger (Not Shown)	1

NOTE: Parts that wear down over the course of normal use (like accessories, batteries, etc.) are not covered by the two-year warranty. Repairs and replacements should only be performed by an authorized technician.

**THANKS FOR
REMEMBERING**

