

EXELAIR™

OPERATOR'S MANUAL

EX4405KIT

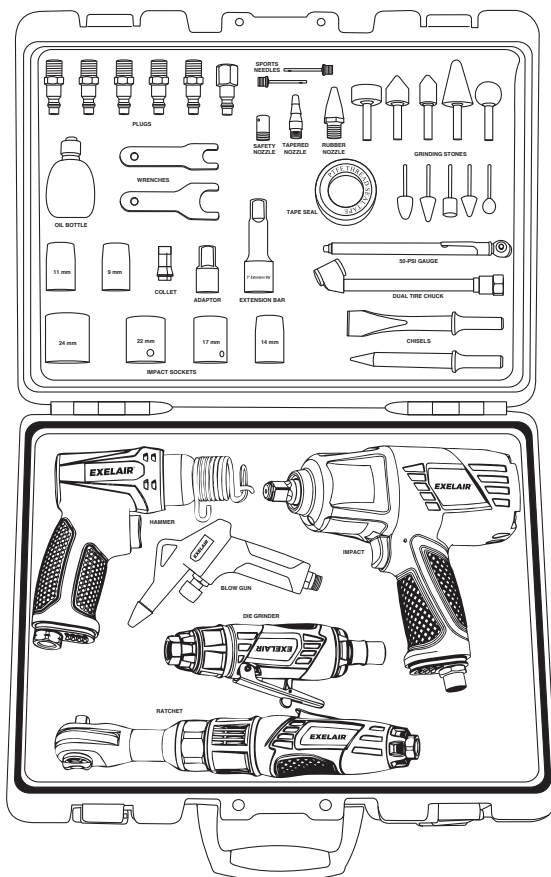

WARNING! Some dust created by using power tools contains chemicals known to the state of California to cause cancer and birth defects or other reproductive harm. This product contains one or more chemicals known to the State of California to cause cancer and birth defects or other reproductive harm. Wash hands after handling.

44-PIECE AIR TOOL KIT

TABLE OF CONTENTS

GENERAL SAFETY RULES.....	2
AIR SUPPLY.....	5
PRODUCT DESCRIPTION.....	7
TECHNICAL SPECIFICATIONS.....	10
ASSEMBLY.....	11
1/2" Air Impact Wrench.....	11
3/8" Air Ratchet Wrench.....	13
Air Hammer.....	14
1/4" Air Die Grinder.....	16
OPERATION.....	19
1/2" Air Impact Wrench.....	19
3/8" Air Ratchet Wrench.....	20
Air Hammer.....	21
1/4" Air Die Grinder.....	22
TROUBLESHOOTING.....	23
CARE AND MAINTENANCE.....	23
EXPLODED DIAGRAMS AND PARTS LISTS.....	24
1/2" Air Impact Wrench.....	24
3/8" Air Ratchet Wrench.....	25
Air Hammer.....	26
1/4" Air Die Grinder.....	27
WARRANTY.....	28



WARNING!

- Improper operation or maintenance of this tool could result in personal injury and/or property damage. Read and understand all warnings and operation instructions before using this tool.
- When using this tool, these basic safety precautions should always be followed to reduce the risk of personal injury and/or property damage.

Workplace conditons

1. Always work in a clean, dry, well-ventilated area free of combustible materials. Never operate the tool near flammable substances such as gasoline, naphtha, cleaning solvent, etc.
2. Dress properly. Do not wear loose clothing. Tie up or cover long hair, remove any jewelry, necklaces, etc., which might become caught by the tool.
3. Keep the work area well lit and free of clutter. Slips, trips and falls are major causes of workplace injury. Be aware of excess air hose left on your walking way or on the working surface.
4. Ensure that there are no electrical cables, gas pipes, etc., which can cause a hazard if damaged by use of the tool.
5. Keep visitors a safe distance from the work area. Keep children away.

Use of air tools

1. Stay alert and use common sense. Watch what you are doing. Do not operate the tool when you are tired or under the influence of alcohol, drugs or medication.
2. Do not overreach. Keep proper footing and balance at all times.
3. Always wear eye protectors which provides protection from flying particles from the front and side when using the tool. Ear protectors should also be worn.
4. Never use oxygen, carbon dioxide, combustible gases or any other type of bottled gases as a power source for this tool.
5. Always verify prior to using this tool that the air source has been adjusted to the rated air pressure range. Never connect to an air source that is capable of exceeding 200psi.
6. Do not connect the air supply hose to the tool with your finger on the trigger.
7. Do not exceed the maximum working pressure 90psi/6.3bar for the tool. Excessive pressure will reduce the tool life and/or might cause a hazardous situation.
8. Never leave the operating tool unattended. Disconnect the air hose when the tool is not in use.
9. Keep the air supply hose away from heat, oil and sharp edges.
10. Check the air supply hose for wear and/or leaks before each use. Make sure that all connections are tight and secure.
11. Do not use the tool for any other than its intended use.
12. Do not carry out any alternations and/or modifications to the tool.
13. Always disconnect the tool from air supply before replacing any accessories, performing any repair and maintenance, moving to another work area, or passing the tool to another person.

14. Never use the tool if it is defective, damaged, or operating abnormally.
15. Check for misalignment or binding of moving parts, breakage of parts and any other condition that affects the tool operation. If damaged, have the tool serviced before using.
16. Keep working parts of the tool away from hands and body.
17. Do not carry the tool by the air hose.
18. Do not apply excessive force of any kind to the tool. Let the tool perform the work at the rate as it was designed.
19. Do not remove any labels on the tool. Replace if they become obscured or damaged.
20. Always maintain the tool with care. Keep it clean for the best and safest performance.
21. It is not recommended that quick change couplings should be located directly at the air inlet, as they add weight and could fail due to vibration.
22. This tool vibrates with use. Continuous operation of this tool might be harmful to your hands or arms. Stop using the tool if discomfort, a tingling feeling or pain occurs. Resume work after recovery. Seek medical advice if a serious symptom occurs.

Air impact wrench safety instructions

1. Always use the impact wrench in the manner and for the functions described in this manual.
2. Always ensure the wrench is not moving and disconnected from the air supply when changing sockets etc. Only use impact sockets. Do not use standard sockets.
3. Always finish tightening wheel nuts or engine parts with a torque wrench or suitable spanner to the correct torque as recommended by the vehicle manufacturer.
4. Always avoid excessive use of the impact wrench. When tightening a nut or bolt, never allow the wrench to impact more than 8 times. This is to avoid over-tightening. 3 to 4 impacts is normally sufficient.
5. Always ensure that the socket is correctly installed onto the tool anvil before starting the tool.
6. Due to the possible presence of asbestos dust from brake linings, always wear suitable respiratory protection.
7. Never carry the impact wrench by the air supply hose.
8. Always disconnect the tool from the air supply when changing impact sockets or when the wrench is not required for immediate use in order to avoid accidental start.
9. Hold the tool correctly. Always use both hands to control the impact wrench.
10. Always ensure that the wrench has come to a complete stop before putting it down after use.
11. If necessary, use clamps or proper devices to securely fix the workpiece when installing/tightening or removing/loosening threaded fasteners on the workpiece.
12. For overhead work, wear a safety helmet.
13. Do not discard the safety instructions, give them to the operator.
14. Always store this product in a dry and safe place out of reach of children or untrained operators.

Air ratchet wrench safety instructions

1. Always use the ratchet wrench in the manner and for the functions described in this manual.
2. Always ensure the wrench is not moving and disconnected from the air supply when changing sockets etc. Only use impact sockets. Do not use standard sockets.
3. Always finish tightening threaded fasteners, bolts or nuts, or engine parts with a calibrated torque wrench by hand to the correct torque as recommended by the manufacturer where critical torque values are required.
4. Where critical torque values are not required, the final tightening of threaded fasteners, bolts or nuts can be slightly tighter if gaskets are used between surfaces.
5. Use penetrating oil to assist in freeing off rusted fasteners, bolts and nuts if necessary.
6. When assembling, first turn fasteners, bolts or nuts by hand onto workpiece. Then start the tool for tightening.
7. Always ensure that the socket is correctly installed onto the tool anvil before starting the tool.
8. Never carry the ratchet wrench by the air supply hose.
9. Always disconnect the tool from the air supply when changing sockets or when the wrench is not required for immediate use in order to avoid accidental start.
10. Always ensure that the wrench has come to a complete stop before putting it down after use.
11. If necessary, use clamps or proper devices to securely fix the workpiece when installing/tightening or removing/loosening threaded fasteners on the workpiece.
12. For overhead work, wear a safety helmet.
13. Do not discard the safety instructions, give them to the operator.
14. Always store this product in a dry and safe place out of reach of children or untrained operators.

Air hammer safety instructions

1. Always use the air hammer in the manner and for the functions described in this manual.
2. Always ensure the tool is disconnected from the air supply when changing chisels.
3. Only use qualified chisels with sharp point or edge. Never use blunt chisels which require excessive pressure and can break from fatigue.
4. Always ensure that the chisel is correctly installed onto the tool before starting the tool.
5. Never contact the chisel during and after use as it can be hot and sharp. Wear suitable gloves to protect hands.
6. If necessary, use clamps or proper devices to securely fix the workpiece.
7. Hold the tool firmly. Always use both hands to control the air hammer.
8. Make sure that there are no hidden electrical cables, gas pipes etc. inside or around the workpiece to be free of a hazard if damaged by action of the chisels.
9. Never carry the tool by the air supply hose.
10. Always disconnect the tool from the air supply when the tool is not required for immediate use in order to avoid accidental start.
11. Always ensure that the tool has come to a complete stop before putting it down after use.
12. Do not discard the safety instructions, give them to the operator.

13. Always store this product in a dry and safe place out of reach of children or untrained operators.

Air die grinder safety instructions

1. Always use the die grinder in the manner and for the functions described in this manual.
2. Always ensure the grinder is not moving and disconnected from the air supply when changing grinding stones etc.
3. Only use qualified grinding stones. Never use chipped or cracked grinding stones.
4. Always ensure that the grinding stone is correctly installed onto the tool before starting the tool.
5. Avoid direct contact with the grinding stone during and after use as it can be hot and sharp. Wear suitable gloves to protect hands.
6. Use respiratory protection when working in certain materials which creates emission of dust and fumes.
7. If necessary, use clamps or proper devices to securely fix the workpiece.
8. Never carry the grinder by the air supply hose.
9. Always disconnect the tool from the air supply when the grinder is not required for immediate use in order to avoid accidental start.
10. Always ensure that the grinder has come to a complete stop before putting it down after use.
11. Do not discard the safety instructions, give them to the operator.
12. Always store this product in a dry and safe place out of reach of children or untrained operators.

AIR SUPPLY

Please refer to the typical air system layout recommended below.



WARNING! Compressed air can be dangerous. Ensure that you are familiar with all precautions relating to the use of compressors and compressed air supply.

1. Use only clean, dry, regulated compressed air as the power source.
2. Make sure that the air compressor being used for the tool operation supplies the correct output (CFM).
3. Have the tool in "off" position when connecting the tool to the air supply.
4. Use normal 90psi working pressure for the tool. High pressure and unclean air will shorten the tool life due to the faster wear and also may create a safety hazard.
5. Drain water from the air compressor tank daily, as well as any condensation in the air lines. Water in the air line may enter the tool and cause damage to the tool mechanisms at operation.
6. Clean the tool air inlet screen filter for blockage weekly. Clean if necessary.
7. Usually a 3/8" (inner diameter) air hose is recommended for air supply and airflow to get the optimum performance of tool.
8. A long air hose (usually over 25 feet) may cause up to 15psi drop in pressure, so you need to set the output pressure of the air compressor higher to maintain the required working pressure at the tool.

9. Use proper hoses and fittings. We do not suggest connecting quick change couplings directly to the tool since they may cause failure due to tool vibration at operation. Instead, add a lead hose and connect coupling between air supply and hose whip.
10. Check hoses for wear before each use. Make certain that all connections are in security.

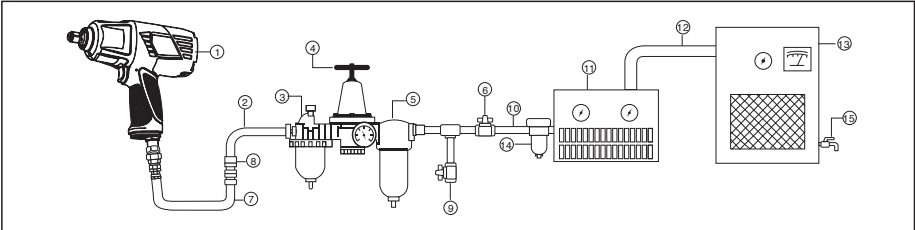

AIR SYSTEM LAYOUT:

- | | | |
|-------------------------|-------------------------------------|-----------------------------------|
| 1. Air Tool | 6. Shut Off Valve | 11. Air Dryer |
| 2. Air Hose 3/8" (I.D.) | 7. Whip Hose | 12. 1" Or Larger Pipe And Fitting |
| 3. Oiler | 8. Coupler Body And Connector | 13. Air Compressor |
| 4. Pressure Regulator | 9. Drain Daily | 14. Auto Drain |
| 5. Filter | 10. 1/2" Or Larger Pipe And Fitting | 15. Drain Daily |

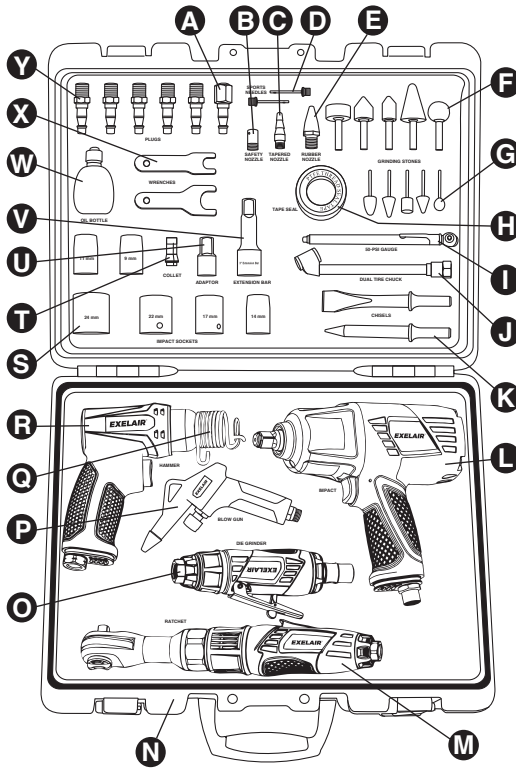

PART	DESCRIPTION	QUANTITY
A	Female Plug	1
B	Safety Nozzle	1
C	Tapered Nozzle	1
D	Sports needle	2
E	Rubber Nozzle	1
F	Grinding Stone (1/4" Shank)	5
G	Grinding Stone (1/8" Shank)	5
H	Seal Tape	1
I	50-psi Tire Gauge	1
J	Dual Tire Chuck	1
K	Chisel	2
L	1/2" Air Impact Wrench	1
M	3/8" Air Ratchet Wrench	1

PART	DESCRIPTION	QUANTITY
N	Case	1
O	1/4" Air Die Grinder	1
P	Blow Gun	1
Q	Spring Retainer	1
R	Air Hammer	1
S	1/2" Impact Socket	6
T	Collet	1
U	3/8" to 1/2" Adapter	1
V	1/2" Extension Bar	1
W	Oil Bottle	1
X	Wrench	2
Y	Male Plug	5

44-PIECE AIR TOOL KIT

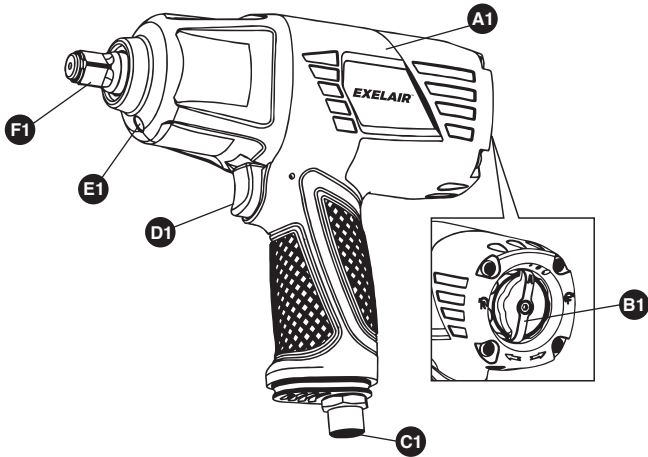

1/2" AIR IMPACT WRENCH

PART	DESCRIPTION	QUANTITY
A1	1/2" Air Impact Wrench	1
B1	Forward/Reverse Rotation Control	1
C1	Air Inlet	1
D1	Trigger	1
E1	Grease Cap	1
F1	Anvil	1

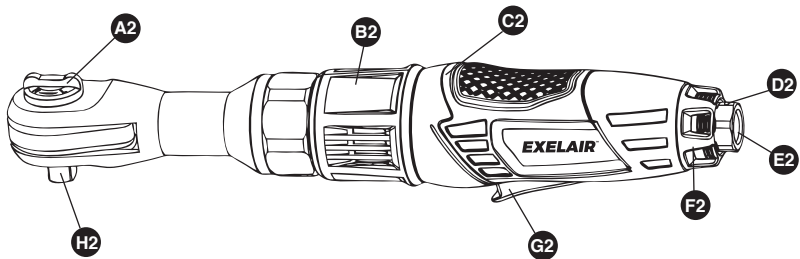

3/8" AIR RATCHET WRENCH

PART	DESCRIPTION	QUANTITY
A2	F/R Knob	1
B2	Exhaust Deflector	1
C2	3/8" Air Ratchet Wrench	1
D2	Steel Ball	1
E2	Air Inlet	1
F2	Air Regulator	1
G2	Trigger	1
H2	Anvil	1

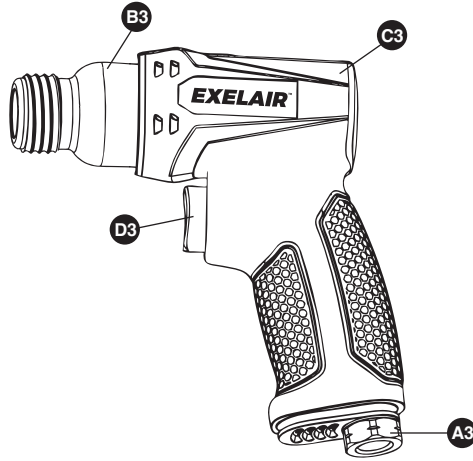

AIR HAMMER

PART	DESCRIPTION	QUANTITY
A3	Air Inlet	1
B3	Cylinder	1
C3	Air Hammer	1
D3	Trigger	

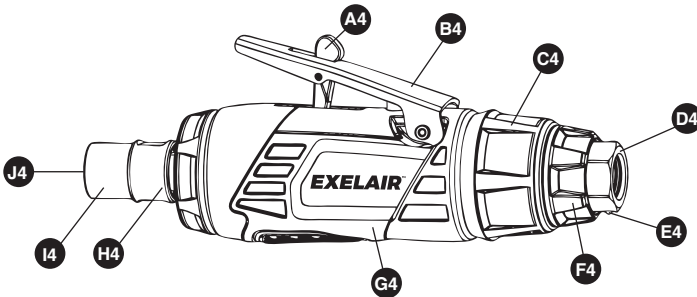

1/4" AIR DIE GRINDER

PART	DESCRIPTION	QUANTITY
A4	Lever	1
B4	Trigger	1
C4	Exhaust Deflector	1
D4	Steel Ball	1
E4	Air Inlet	1
F4	Air Regulator	1
G4	1/4" Air Die Grinder	1
H4	Collet Holder	1
I4	Collet Jacket	1
J4	Collet	1

1/2" AIR IMPACT WRENCH

COMPONENT	SPECIFICATIONS
Square drive	1/2"
Maximum no load speed	7,000rpm
Maximum torque	500Ft-Lb (680Nm)
Air inlet	1/4" NPT
Air hose (inner diameter)	3/8"
Average air consumption	6.5cfm
Working pressure	90psi (6.3bar)

3/8" AIR RATCHET WRENCH

COMPONENT	SPECIFICATIONS
Square drive	3/8"
Maximum no load speed	160rpm
Maximum torque	60Ft-Lb (85Nm)
Air inlet	1/4" NPT
Air hose (inner diameter)	3/8"
Average air consumption	4cfm
Working pressure	90psi (6.3bar)

AIR HAMMER

COMPONENT	SPECIFICATIONS
Chisel shank	0.4" (10.2mm)
Stroke length	1-5/8" (41mm)
Blow per min	4,500bpm
Air inlet	1/4" NPT
Air hose (inner diameter)	3/8"
Average air consumption	4.5cfm
Working pressure	90psi (6.3bar)

1/4" AIR DIE GRINDER

COMPONENT	SPECIFICATIONS
Maximum no load speed	25,000rpm
Collets	1/4", 1/8"
Air inlet	1/4" NPT
Air hose (inner diameter)	3/8"
Average air consumption	4cfm
Working pressure	90psi (6.3bar)

ASSEMBLY

1/2" AIR IMPACT WRENCH

1. Remove the air inlet protective cap from the air inlet (C1). (See Figure 1)

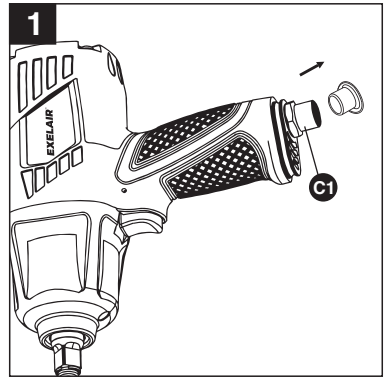

11

2. Mount a male plug by hand into the air inlet (C1). (See Figure 2)



NOTE: Use thread sealant tape on the male plug and tighten it with a wrench for airtight connection. Do not overtighten.

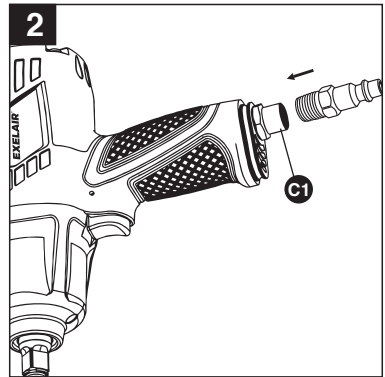

3. Place 2 - 3 drops of air tool oil into the male plug before each use. (See Figure 3)

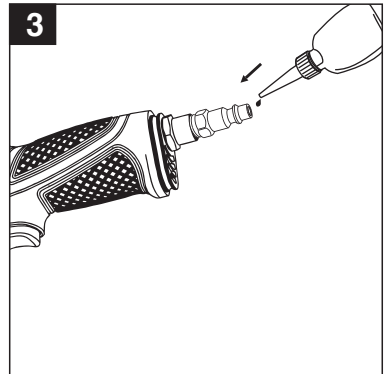

4. Choose the correct impact socket (S) as needed and mount it onto the anvil (F1).
(See Figure 4)



WARNING! Only use impact sockets that have a RPM and Torque rating equal to or greater than the tool itself.

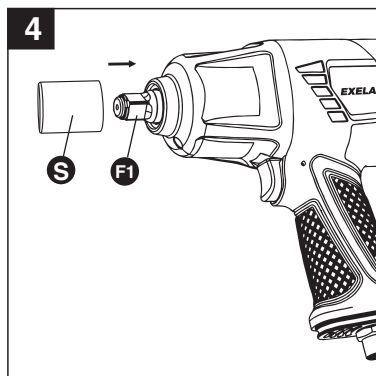

5. If necessary, use the 1/2" extension bar (V) and then mount impact socket onto the bar.
(See Figure 5)

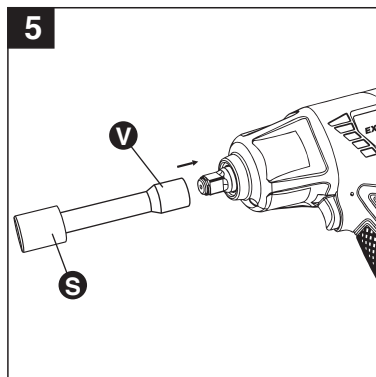

6. Connect air supply hose to the male plug.
(See Figure 6)

7. Set the working pressure at 90psi/6.3bar for best tool performance.



NOTE: Working pressure refers to the air line pressure set to tool when tool is under working conditions.

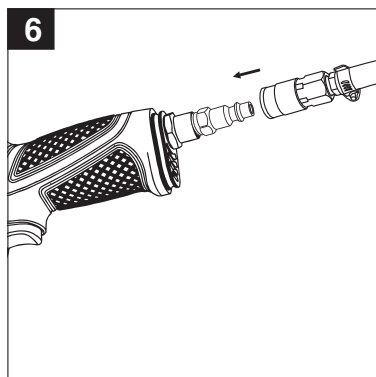

3/8" AIR RATCHET WRENCH

1. Remove the air inlet protective cap from the air inlet (E2). (See Figure 7)

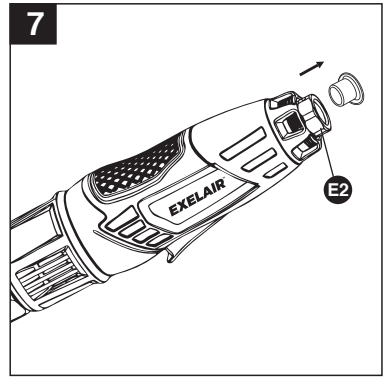

2. Mount the male plug by hand into the air inlet (E2). (See Figure 8)



NOTE: Use thread sealant tape on the male plug and tighten it with a wrench for airtight connection. Do not overtighten.

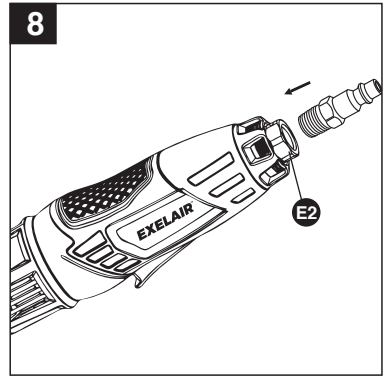

3. Place 2 - 3 drops of air tool oil into the male plug before each use. (See Figure 9)

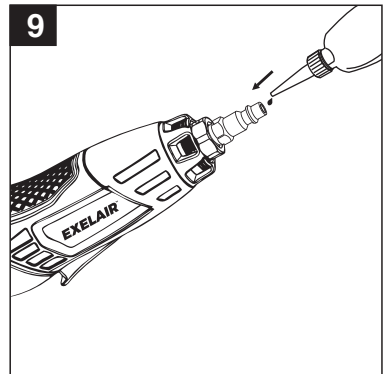

4. Choose the correct impact socket (S) as needed and mount it onto the anvil (H2).
(See Figure 10)



WARNING! Only use impact sockets that have a RPM and Torque rating equal to or greater than the tool itself.

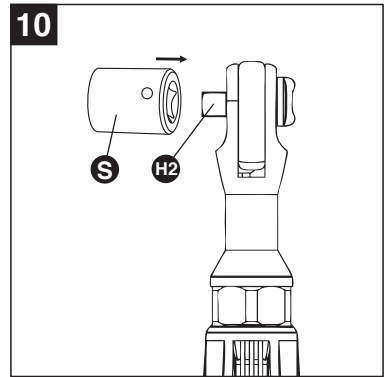

5. Connect air supply hose to the male plug.
(See Figure 11)

6. Set the working pressure at 90psi/6.3bar for best tool performance.



NOTE: Working pressure refers to the air line pressure set to tool when tool is under working conditions.

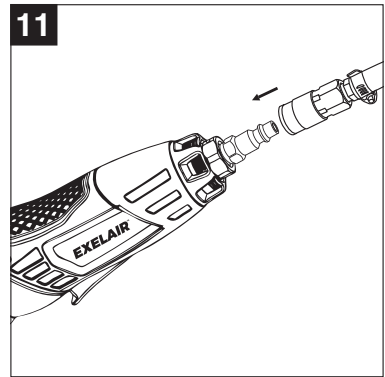

AIR HAMMER

1. Remove the air inlet protective cap from the air inlet (A3). (See Figure 12)

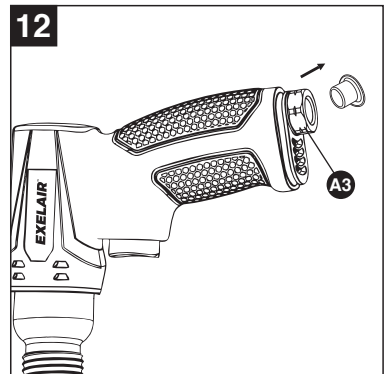

2. Mount the male plug by hand into the air inlet (A3). (See Figure 13)



NOTE: Use thread sealant tape on the male plug and tighten it with a wrench for airtight connection. Do not overtighten.

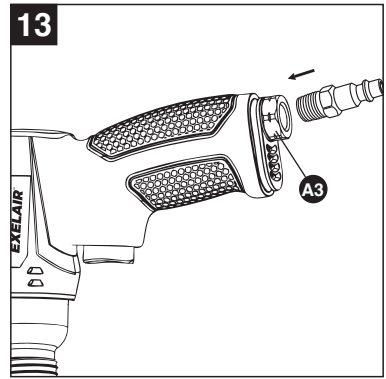

3. Place 2 - 3 drops of air tool oil into the male plug before each use. (See Figure 14)

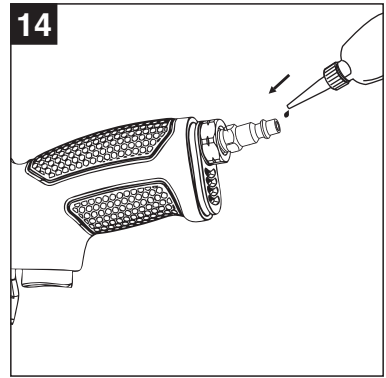

4. Insert a chisel (K) into the opening of cylinder (B3). (See Figure 15)

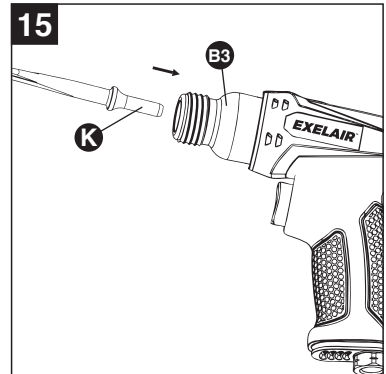

5. Screw the spring retainer (Q) onto the cylinder (B3) and firmly secure it.
(See Figure 16)

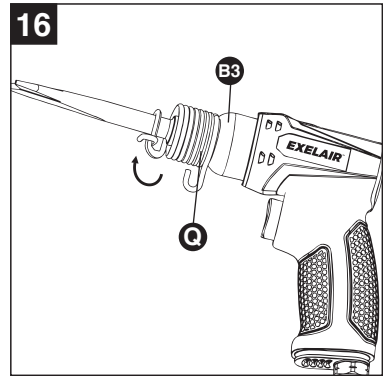

6. Connect air supply hose to the male plug.
(See Figure 17)

7. Set the working pressure at 90psi/6.3bar for best tool performance.



NOTE: Working pressure refers to the air line pressure set to tool when tool is under working conditions.

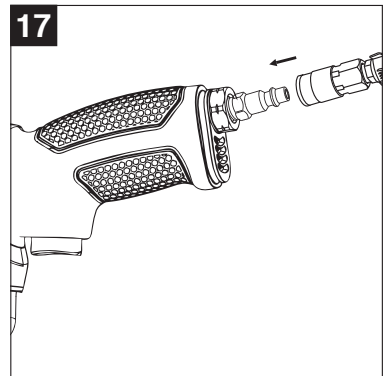

1/4" AIR DIE GRINDER

1. Remove the air inlet protective cap from the air inlet (E4). (See Figure 18)

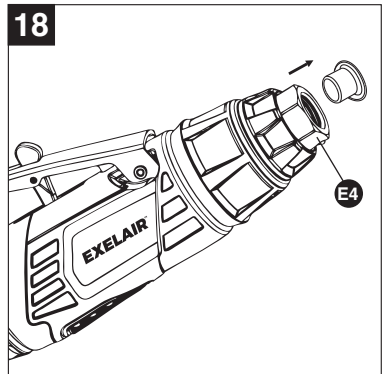

2. Mount a male plug by hand into the air inlet (E4). (See Figure 19)



NOTE: Use thread sealant tape on the male plug and tighten it with a wrench for airtight connection. Do not overtighten.

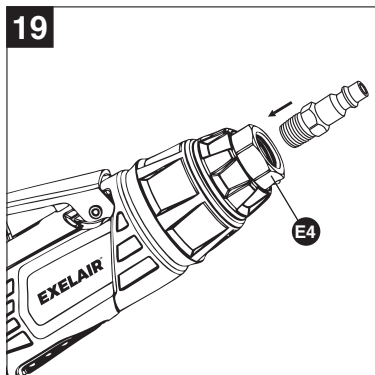

3. Place 2 - 3 drops of air tool oil into the male plug before each use. (See Figure 20)

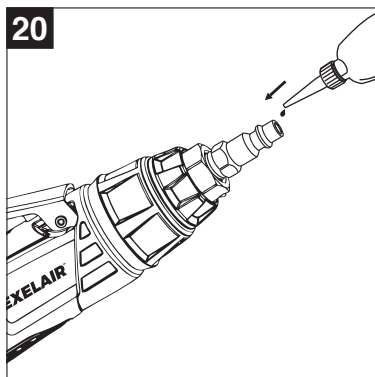

4. Loosen the collet jacket (I4) counterclockwise by hand or with the large wrench while holding the small wrench on the flats of the collet holder (H4). (See Figure 21)

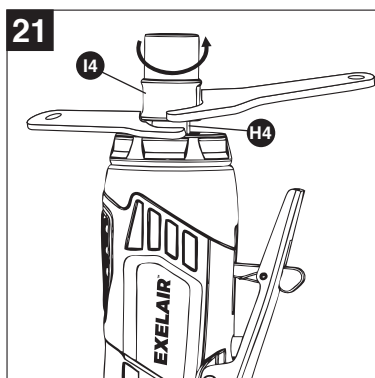

5. Insert a grinding stone (F/G) into the collet (J4). (See Figure 22)



NOTE: Two collets of different sizes (1/4", 1/8") are provided. Select whichever fits the shank of the stone you have chosen.

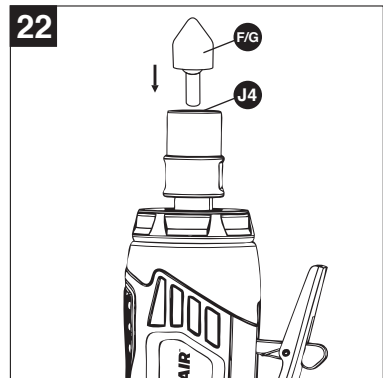

6. Tighten the collet jacket (I4) clockwise with large wrench while holding the small wrench on the flats of the collet holder (H4). Make sure that the grinding stone is installed securely and tightly. (See Figure 23)



WARNING! Only use grinding accessories that have a RPM and Torque rating equal to or greater than the tool itself.

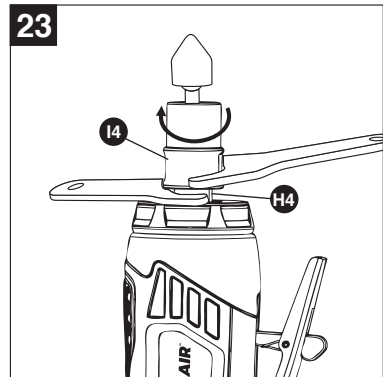

7. Connect air supply hose to the male plug. (See Figure 24)

8. Set the working pressure at 90psi/6.3bar for best tool performance.



NOTE: Working pressure refers to the air line pressure set to tool when tool is under working conditions.

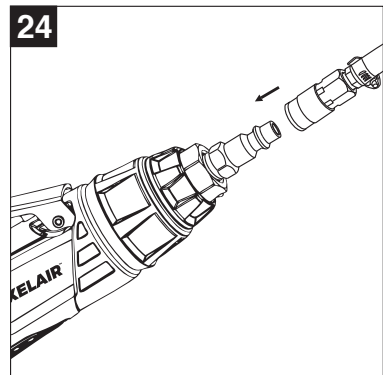

OPERATION

1/2" AIR IMPACT WRENCH

1. How to install/tighten threaded fasteners.
Push the Forward/Reverse rotation control (B1) forward and have the arrow on the Forward/Reverse rotation control (B1) pointing at either of the three dots on the back housing as shown. Press the trigger (D1). The tool anvil (F1) runs clockwise. (See Figure 25)
2. How to remove/loosen threaded fasteners.
Push the Forward/Reverse rotation control (B1) backward and have the arrow on the Forward/Reverse rotation control (B1) pointing at the dot on the back housing as shown. Press the trigger (D1). The tool anvil (F1) runs counterclockwise. (See Figure 26)



NOTE: This tool features a power regulator valve. Turn the Forward/Reverse rotation control (B1) slowly forward and three clicks will be detected. The three clicks do not denote a specific power output but are only for reference. The first click stands for the least amount of power, which is suitable for just mounting threaded fasteners on workpiece. The third click stands for the most amount of power, which is for tightening threaded fasteners on workpiece. This tool operates in maximum power in reverse, which releases threaded fasteners from workpiece with ease. Choose the correct torque needed on workpiece when mounting or releasing threaded fasteners by understanding the reference torque listed below. (See Figure 27)

Setting	Torque in Forward	Torque in Reverse
1st Click	135 ft-lbs (+/- 10%)	
2nd Click	440 ft-lbs (+/- 10%)	515 ft-lb (+/- 10%)
3rd Click	500 ft-lbs (+/- 10%)	

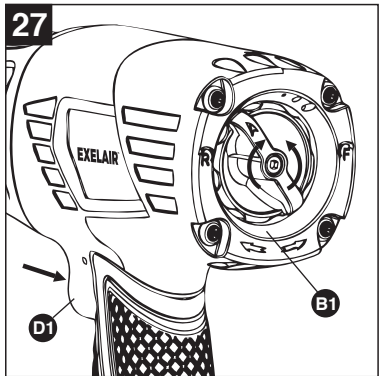
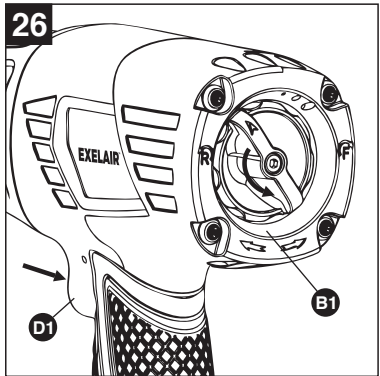
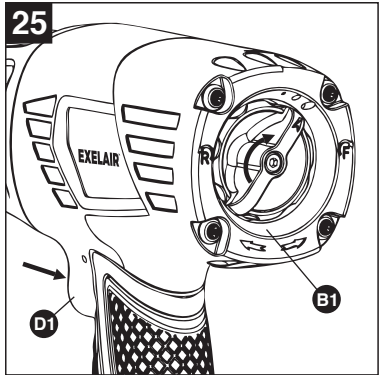



NOTE: This tool also features a grease cap (E) on the protector cover. Remove the screw in the grease cap (E1) with a hex key (not provided). Use a grease gun (not provided) and insert the gun nozzle into the grease cap (E1). Several drops of grease are recommended for lubricating the internal hammer assembly. This will help the hammer assembly to work in good condition and extend tool life. Lubricate the hammer assembly once every working day. (See Figure 28)

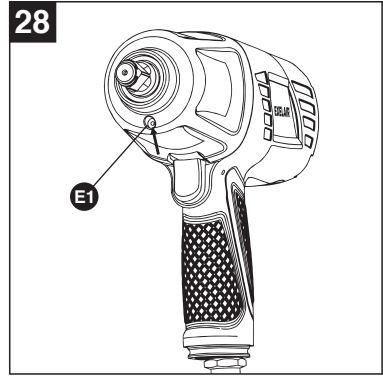

3/8" AIR RATCHET WRENCH

- How to install/tighten threaded fasteners.
Turn the F/R knob (A2) counterclockwise to "F" position (F=Forward or Tighten). Press the trigger (G2). The tool anvil (H2) runs clockwise. (See Figure 29)

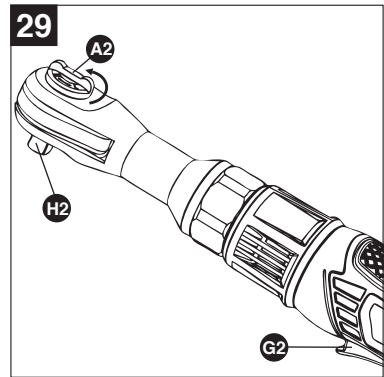

- How to remove/loosen threaded fasteners.
Turn the F/R knob (A2) clockwise to "R" position (R=Reverse or Loosen). Press the trigger (G2). The tool anvil (H2) runs counterclockwise. (See Figure 30)

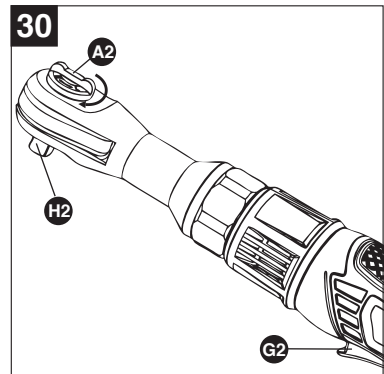



NOTE: This tool features a power regulator valve. Rotate the air regulator (F2) until desired output is achieved. The settings 1, 2, 3, 4 are only for reference and do not denote a specific power output. “Setting 1” (one-line symbol) is the least amount of power while “Setting 4” (four-line symbol) is the most amount of power. Rotate the air regulator (F2) until the desired setting is lined up with the small steel ball (D2) on air inlet (E2). (See Figure 31)

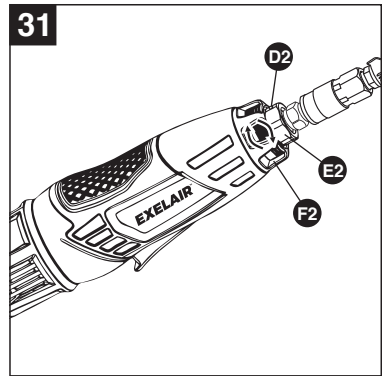

NOTE: This tool features an exhaust deflector (B2) 9 which can be rotated to any position to direct air away from workpiece or operator. (See Figure 32)

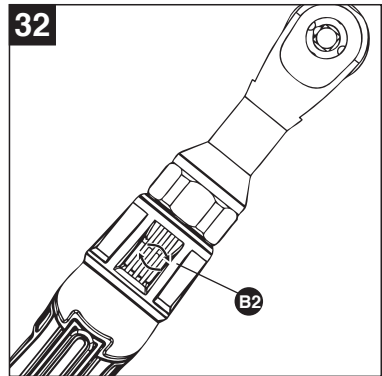

AIR HAMMER

1. Hold the tool firmly with both hands. Bring the tool towards the workpiece at an angle of 60-70 degrees approximately.
2. Press the trigger (D3) slowly with the chisel in light contact with the workpiece. (See Figure 33)
3. Slowly move the chisel across the workpiece surface.



NOTE: When removing scale, rust or other contaminants, you only need to apply a light force on the tool.



NOTE: Keep the chisel contacting the workpiece while you are releasing the trigger to stop operation. The tool may impact briefly after the trigger is released.

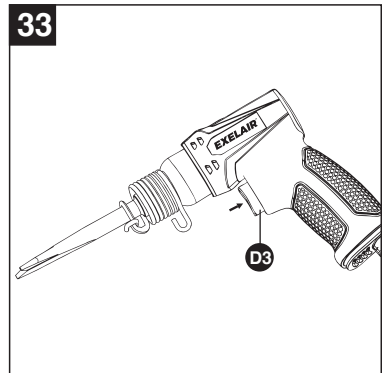

1/4" AIR DIE GRINDER

Push lever (A4) forward and press down on the trigger (B4) to start the tool (G4). (See Figure 34)

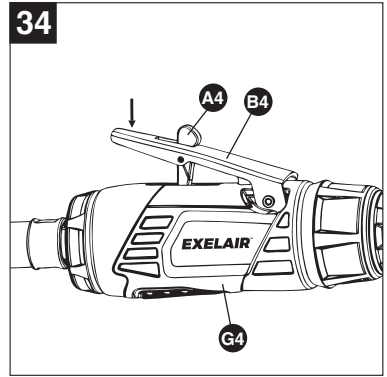

NOTE: This tool features a power regulator valve. Rotate the air regulator (F4) until desired output is achieved. The settings 1, 2, 3, 4 are only for reference and do not denote a specific power output. “Setting 1” (one-line symbol) is the lowest speed while “Setting 4” (four-line symbol) is the highest speed. Rotate the air regulator (F4) until the desired setting is lined up with the small steel ball (D4) on air inlet (E4). (See Figure 35)

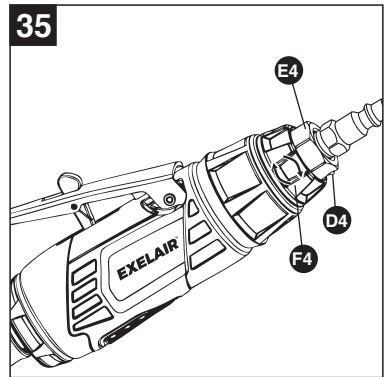

NOTE: This tool also features an exhaust deflector (C4) which is rotatable to direct air away in any directions. (See Figure 36)

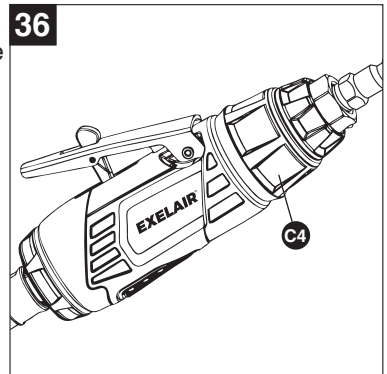

PROBLEM	POSSIBLE CAUSE	CORRECTIVE ACTION
Tool runs slowly or will not operate	1. Grit or gum in tool.	1. Flush the tool with air-tool oil or gum solvent.
	2. No oil in tool.	2. Lubricate the tool.
	3. Low air pressure.	3. a. Adjust the regulator on the tool to maximum setting. b. Adjust the compressor regulator to tool maximum of 90 PSI/6.3 BAR.
	4. Air hose leaks.	4. Tighten and seal hose fittings if leaks are found. Use sealing tape.
	5. Pressure drops.	5. a. Be sure the hose is the proper size. Long hose or tools using large volumes of air may require a hose with an I.D. of 1/2 in. or larger depending on the total length of the hoses. b. Do not use a multiple number of hoses connected together with quick-connect fittings. This causes additional pressure drops and reduces the tool power. Directly connect the hoses together.
	6. Worn rotor blade.	6. Replace rotor blade.
	7. Moisture blowing out of tool exhaust.	7. Water in tank; drain tank. (See air compressor manual). Oil tool and run until no water is evident. Oil tool again and run 1-2 seconds.

CARE AND MAINTENANCE

An in-line oiler is recommended to be installed on air supply line as it increases tool life and keeps the tool in sustained operation. The in-line oiler should be regularly checked and filled with air-tool oil. Proper adjustment of the in-line oiler is performed by placing a sheet of paper next to the tool's exhaust ports and holding the throttle open approximately 30 seconds. The in-line oiler is properly set when a light stain of oil collects on the paper. Excessive amounts of oil should be avoided.

In the event that it becomes necessary to store the tool for an extended period of time, it should receive a generous amount of lubrication at that time. The tool should be run for approximately 30 seconds to ensure oil has been evenly distributed throughout the tool. The tool should be stored in a clean and dry environment.

Recommended lubricants: use air-tool oil or any other high-grade turbine oil containing moisture absorbent, rust inhibitors, metal wetting agents and an EP (extreme pressure) additive.

Clean the tool all over with a cotton rag after each use. Keep the tool in a dry and safe place out of reach of children.

EXPLODED DIAGRAM AND PARTS LIST

1/2" AIR IMPACT WRENCH

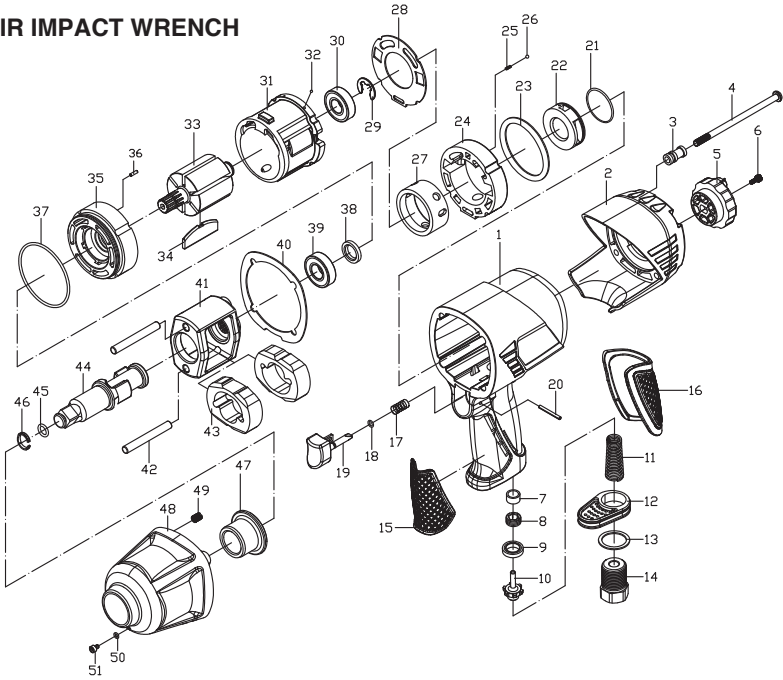

Part No.	Description	Qty.
1	Main housing*	1
2	Housing cover*	1
3	Bushing*	4
4	Screw*	4
5	F/R switch*	1
6	Screw*	1
7	Gasket*	1
8	Fix nut - EX1250IW-08	1
9	Spacer*	1
10	Throttle valve*	1
11	Spring - EX1250IW-11	1
12	Muffler*	1
13	Cushion*	1
14	Air inlet*	1
15	Soft grip*	1
16	Soft grip*	1
17	Spring*	1
18	O-ring*	1
19	Trigger*	1
20	Bolt*	1
21	O-ring*	1
22	Air flow regulator*	1
23	Gasket*	1
24	Valve seat*	1
25	Spring*	1
26	Steel ball*	1
27	Bushing*	1
28	Gasket*	1
29	E-clip*	1
30	Bearing*	1
31	Cylinder*	1
32	Steel ball*	2
33	Rotor*	1
34	Rotor blade - EX1250IW-34	6
35	Front cover*	1
36	Bolt*	1
37	O-ring*	1
38	Spacer*	1
39	Bearing*	1
40	Gasket*	1
41	Hammer case*	1
42	Dowel pin*	2
43	Hammer dog*	2
44	Anvil*	1
45	O-ring*	1
46	Anvil clip*	1
47	Anvil bushing*	1
48	Front housing*	1
49	Screw*	4
50	O-ring*	1
51	Grease cap*	1

Part No.	Description	Qty.
27	Bushing*	1
28	Gasket*	1
29	E-clip*	1
30	Bearing*	1
31	Cylinder*	1
32	Steel ball*	2
33	Rotor*	1
34	Rotor blade - EX1250IW-34	6
35	Front cover*	1
36	Bolt*	1
37	O-ring*	1
38	Spacer*	1
39	Bearing*	1
40	Gasket*	1
41	Hammer case*	1
42	Dowel pin*	2
43	Hammer dog*	2
44	Anvil*	1
45	O-ring*	1
46	Anvil clip*	1
47	Anvil bushing*	1
48	Front housing*	1
49	Screw*	4
50	O-ring*	1
51	Grease cap*	1

*Replacement part not available

44-PIECE AIR TOOL KIT

EXPLODED DIAGRAM AND PARTS LIST

3/8" AIR RATCHET WRENCH

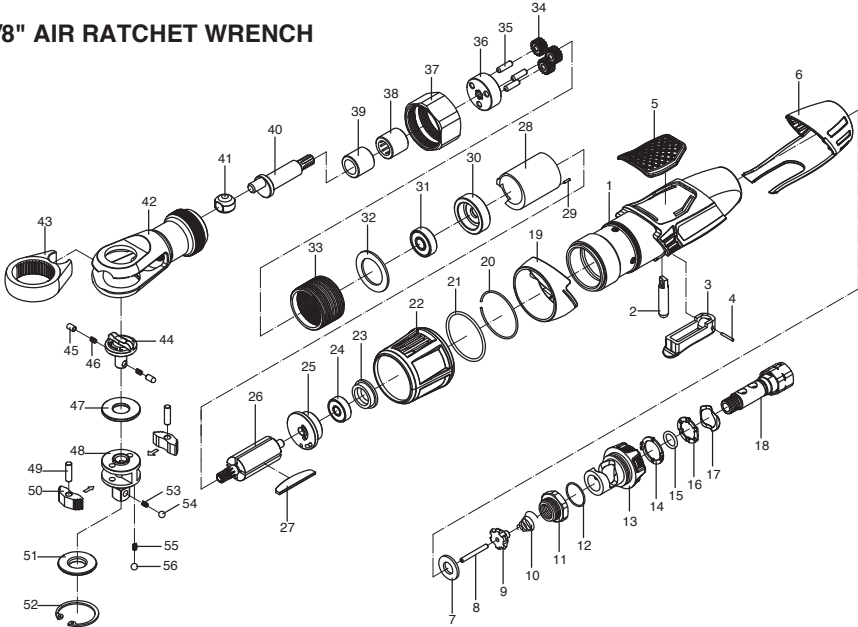

Part No.	Description	Qty.
1	Main housing*	1
2	Bolt*	1
3	Trigger - EX3860AR1-03	1
4	Bolt*	1
5	Soft grip*	1
6	Rear cover*	1
7	Valve seat - EX3860AR1-08	1
8	Bolt*	1
9	Throttle valve*	1
10	Spring*	1
11	Screw cap*	1
12	O-ring*	1
13	Air regulator*	1
14	Set plate*	1
15	O-ring*	1
16	Set plate*	1
17	Gasket*	1
18	Air inlet*	1
19	Front cover*	1
20	Clip*	1
21	O-ring*	1
22	Exhaust deflector*	1
23	Bearing cap*	1
24	Bearing*	1
25	Rear plate*	1
26	Rotor*	1
27	Rotor blade - EX3860AR1-26	4
28	Cylinder*	1

Part No.	Description	Qty.
29	Pin*	1
30	Front plate*	1
31	Bearing*	1
32	Washer*	1
33	Thread ring gear*	1
34	Idle gear*	3
35	Gear pin*	3
36	Gear plate*	1
37	Clamp nut*	1
38	Ring gear*	1
39	Bushing*	1
40	Crankshaft*	1
41	Drive bushing*	1
42	Ratchet housing*	1
43	Ratchet yoke*	1
44	F/R knob*	1
45	Sleeve*	2
46	Spring - EX 3860AR2-46	2
47	Washer*	1
48	Ratchet head*	1
49	Pin*	2
50	Ratchet pawl*	2
51	Thrust washer*	1
52	Retainer spring*	1
53	Spring*	1
54	Steel ball*	1
55	Spring- EX3860AR2-55	2
56	Steel ball*	2

*Replacement part not available

44-PIECE AIR TOOL KIT

AIR HAMMER

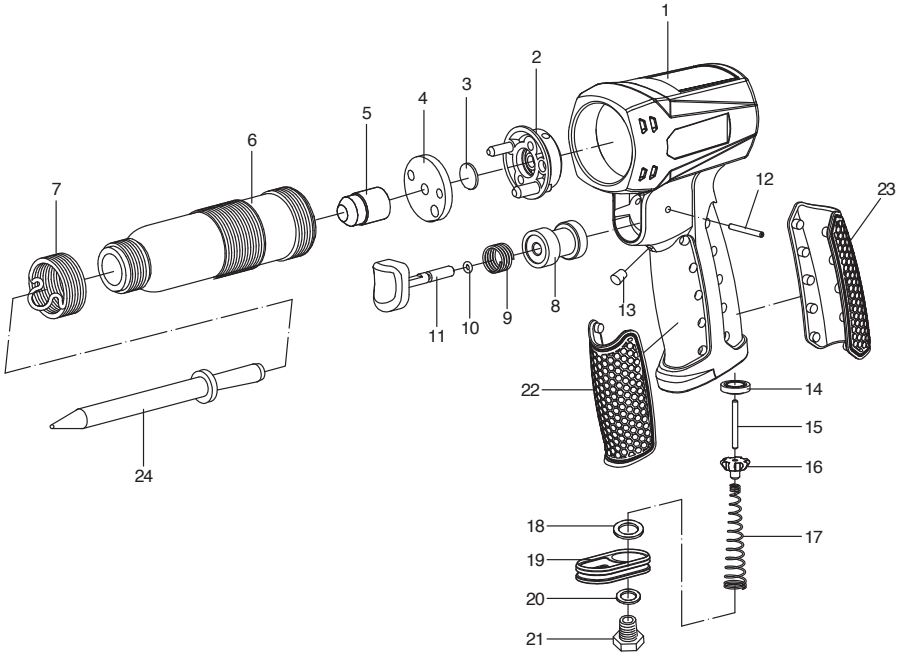

Part No.	Description	Qty.
1	Housing*	1
2	Valve seat - EX0445AH1-05	1
3	Valve - EX0445AH1-06	1
4	End cap - EX0445AH1-07	1
5	Piston*	1
6	Cylinder*	1
7	Spring retainer*	1
8	Trigger sleeve*	1
9	Spring*	1
10	O-ring*	1
11	Trigger*	1
12	Set pin*	1

Part No.	Description	Qty.
13	Plug*	1
14	Oil seal - EX1235IW-34	1
15	Pin*	1
16	Pin cover*	1
17	Spring - EX0445AH2-17	1
18	Washer*	1
19	Exhaust deflector*	1
20	Spacer*	1
21	Air inlet*	1
22	Soft grip*	1
23	Soft grip*	1
24	Chisel*	4

*Replacement part not available

1/4" AIR DIE GRINDER

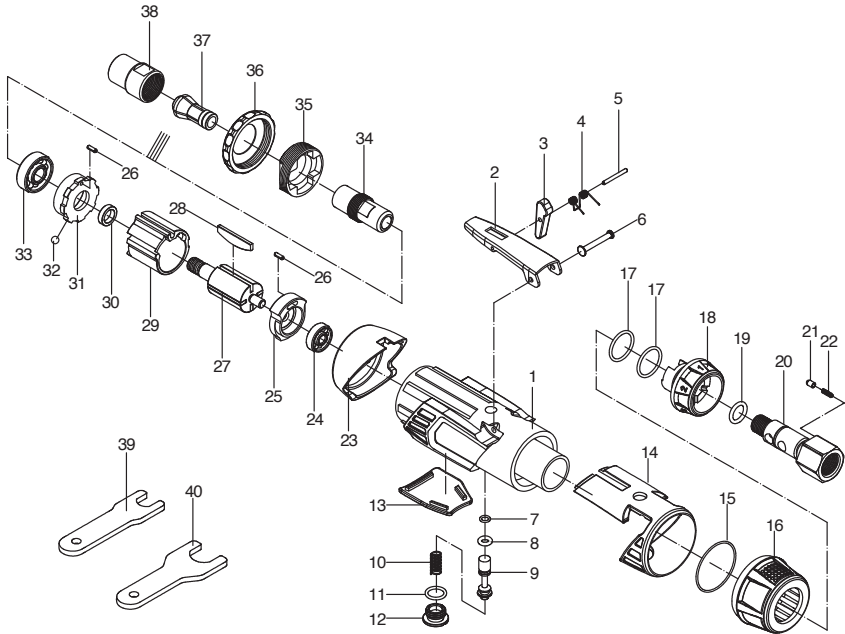

Part No.	Description	Qty.
1	Housing*	1
2	Trigger*	1
3	Lever block*	1
4	Spring*	1
5	Bolt*	1
6	Trigger pin*	1
7	O-ring - EX1425DG1-08	1
8	O-ring - EX1425DG1-09	1
9	Valve stem*	1
10	Spring*	1
11	O-ring*	1
12	Screw nut*	1
13	Soft grip*	1
14	Plastic cover*	1
15	O-ring*	1
16	Muffler*	1
17	O-ring*	2
18	Air regulator*	1
19	O-ring*	1
20	Air inlet*	1

Part No.	Description	Qty.
21	Pin*	1
22	Spring- EX1425DG2-22	1
23	Front cover*	1
24	Bearing*	1
25	Rear plate*	1
26	Bolt*	2
27	Rotor*	1
28	Rotor blade - EX1425DG1-30	4
29	Cylinder*	1
30	Bushing*	1
31	Front plate*	1
32	Steel ball*	1
33	Bearing*	1
34	Collet seat*	1
35	Set ring*	1
36	Protective cover*	1
37	Collet*	1
38	Collet jacket*	1
39	Small wrench*	1
40	Large wrench*	1

*Replacement part not available

EXELAIR™

MILTON INDUSTRIES AIR TOOL WARRANTY POLICY

3 YEAR LIMITED WARRANTY

Please visit www.miltonindustries.com to register this product for the 3-Year limited warranty offered by Milton.

To make any warranty claims or to learn more about the 3 year warranty please visit www.miltonindustries.com



For questions about our warranty on this product, contact us at:

MILTON INDUSTRIES, INC.

4500 W. CORTLAND STREET,

CHICAGO, IL 60639

Phone: 855-G04-MILT (855-464-6458)

www.exel-air.com

44-PIECE AIR TOOL KIT