

# WHOLE HOUSE WATER FILTERS

## INSTALLATION INSTRUCTION & OWNER'S MANUAL Ver 1.2



**APEC WATER**



FREE DRINKING WATER.COM

All Rights Reserved © APEC Water Systems



# Thank you for choosing APEC Water Systems. You now own the finest water filter in America.

**Please read and become familiar with instructions and parts needed before proceeding with the installation.**

(This manual is constructed for standard APEC 10" and 20" BB Whole House Water Filters.)

## General Installation / Operation / Maintenance Requirements

- Use a Licensed Plumber to Install this product.
- Check with your state and local public works department for plumbing and sanitation codes. You must follow these guidelines as you install the whole house water filter. the water filter.
- Do not use with water that is microbiologically unsafe or of unknown quality without adequate disinfecting before or after.

### Required tools list:

- 2 adjustable wrenches
- Pipe cutter or hacksaw
- File
- Emery paper
- Screwdriver
- Teflon tape

### Contents included with the system:

- Filter housing and cap
- Filter cartridge
- Product literature

### Additional installation parts may be required (self-provide):

- 2 adapter fittings to connect household plumbing to 1" female NPT threads on filter housing.
- 3 shut-off valves
- Grounding clamps and 6-gauge copper grounding wire.
- Mounting Bracket
- Housing wrench

### Before Installation:

- **Inspect the system:** Please take the system and all the components out of the box. Inspect the system and all the connection fittings carefully, make sure nothing is damaged during shipping. If any part is cracked or broken, please do not proceed with the installation and contact APEC or your distributor for an exchange or diagnosis.
- Use the whole house water filter on a potable, safe-to-drink, home COLD water supply only. The filter cartridge WILL NOT make unsafe water safe to drink.
- Protect the whole house water filter and piping from freezing. Water freezing in the water filter will damage it.
- This water filter system will withstand up to 90 psi water pressure. If your house's water pressure is higher than 90 psi, install a pressure reducing valve before the system is installed.
- DO NOT install on HOT WATER. The temperature of the water supply to the water filter must be between 40F minimum and 100 F maximum.
- DO NOT solder any fittings directly on the unit. The heat from the soldering process will damage the unit.
- DO NOT install the water filter in an outside location or anywhere it will be exposed to direct sunlight.

### Copyright:

This manual is copyrighted by APEC Inc. Under the copyright laws, this manual may not be reproduced in any form, in whole or part, without the prior written consent of APEC Inc. Manual print ver. 2.0, 2015 Jun.

# STEP BY STEP INSTALLATION INSTRUCTIONS

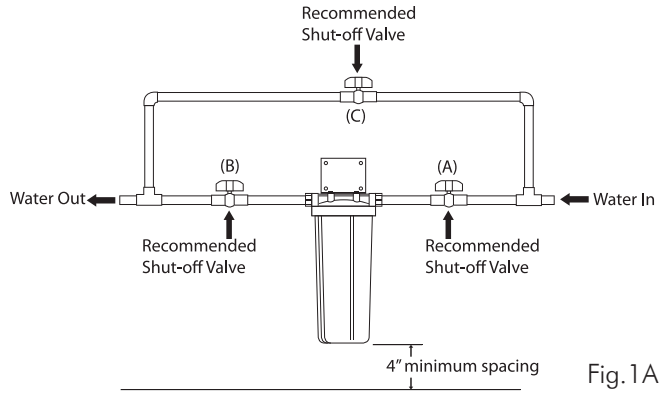

Fig. 1A

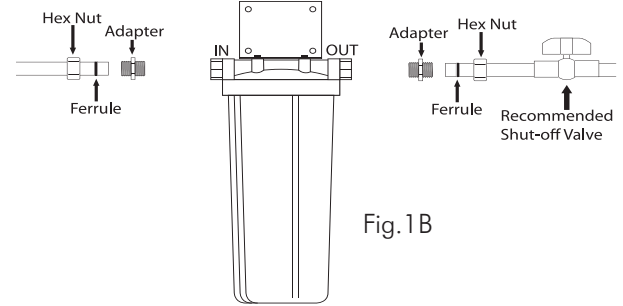

Fig. 1B

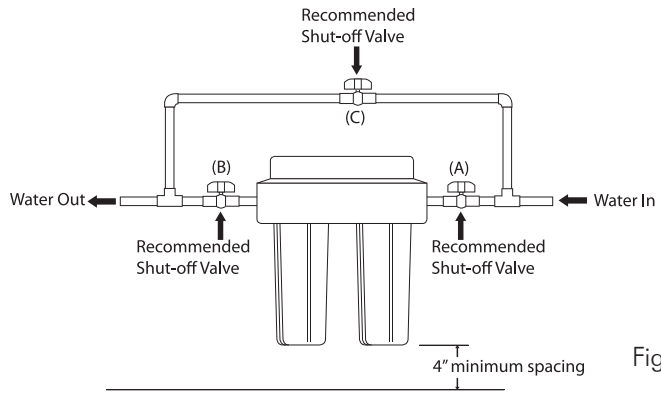

Fig. 2A

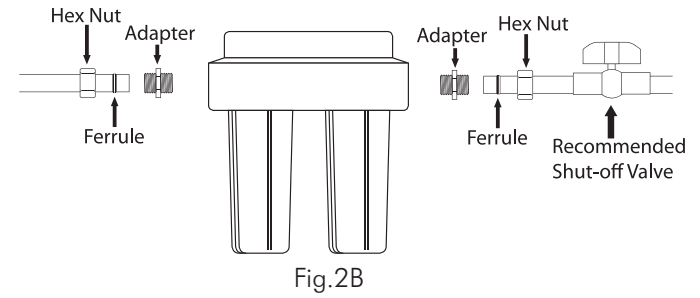

Fig. 2B

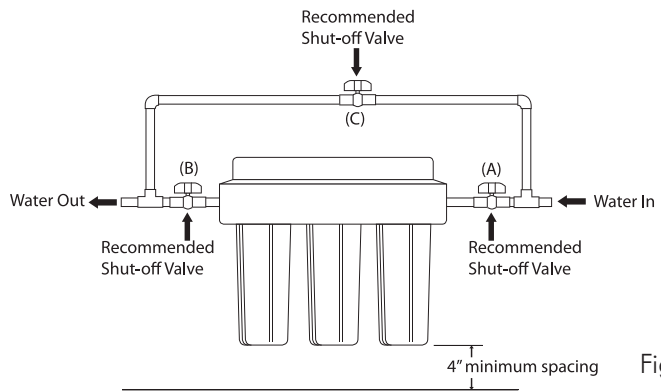

Fig. 3A

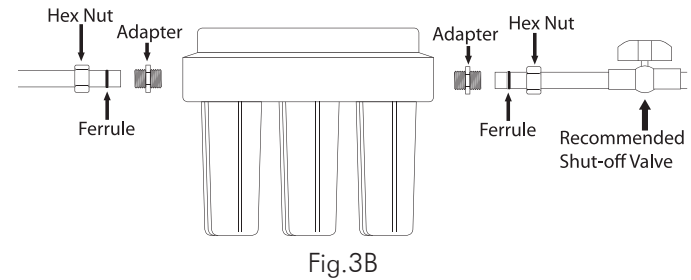

Fig. 3B

## Installation Overview

1. Be sure to allow a minimum space of **4"** under the filter for removing the sump to change the cartridge.
2. Select a location for the filter that is:
  - Protected from freezing.
  - Not exposed to direct sunlight.
3. Whole house water filter setup (Fig 1A,2A,3A):

\*\*\*It is strongly recommended to install a bypass connection and shut off valves for this filter (see Fig 1-3A) and a filter housing mounting bracket.

A. Normal operation: Water flows in to shut-off valve **A**, filter system, then out through valve **B** into the home. Always turn on valve **A** & **B** and turn off valve **C**.

B. If filter needs to be replaced, please turn off the shut-off valve **A** and **C** and turn on the nearest faucet to release pressure so the filter housing can be easily removed. **B** valve should still be turned on.

C. If filter housing is leaking, please turn off shut-off valve **A** and **B** and turn on **C** valve so water can flow into the home bypassing valves **A** & **B** to stop the leak. **B** valve needs to be turned off to avoid water backflow into the filter housing.

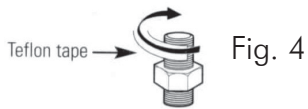

Fig. 4

## Step 1: Install Adapter Fittings

Instructions are for installing similar adapter (fittings) onto copper plumbing. If the unit is to be installed on any other type of tubing (plastic, PVC, galvanized), different hardware must be purchased.

1. Apply 10 to 15 wraps of Teflon tape, in a clockwise direction, to the pipe threads of each adapter. **DO NOT** use joint compound on any parts connecting to filter canister.
2. Assemble an adapter fitting to the inlet and outlet of the canister cap. Start each fitting by hand to make sure they don't cross thread.
3. Use an adjustable wrench to tighten the fittings firmly. **DO NOT OVERTIGHTEN**. About one to two thread(s) should remain visible.

## Step 2: Cut Water Line

1. Turn off the water supply and open a nearby faucet to drain water out of pipes.
2. Remove the nut and brass ferrule from both adapter fittings and set aside. Using a tape measure or ruler, measure the distance "D" as shown below. The distance to cut will vary for the Single, Duo and Trio unit. **See Fig 5.**

**NOTE:** It is recommended that the shut off valve be placed before and after the filter as shown in the Installation Overview illustration. **See Fig 1, Page 2.**

3. Select the location for the filter. Mark the distance "D" on the pipe.
4. Using a pipe cutter or hacksaw, cut pipe. Sand file cut ends of pipe to assure that they are square and smooth.

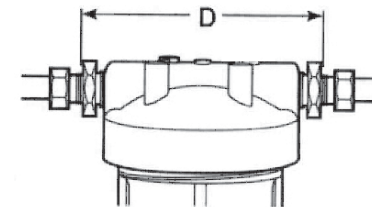
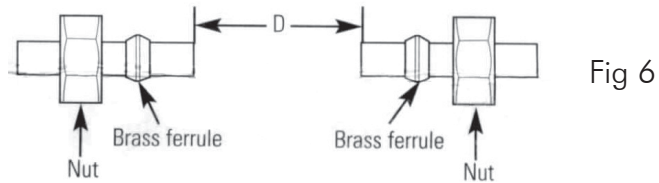

Fig.5

### Step 3: Attach Adapter Fittings to Water Line.

1. Slip a compression nut onto each pipe.
2. Next, slip the brass ferrule onto each pipe. **See Fig.6**



### Step 4: Installing the Unit

1. Align the filter canister with pipe ends making certain that the incoming water supply is going into the filter port marked "IN". It may be necessary to spread the pipe ends apart to install filter.
2. Using two adjustable wrenches, hold incoming adapter securely with one wrench and tighten nut with second wrench. Repeat this procedure for outgoing adapter.
3. If necessary, support the water pipes on either side of the filter unit.

### Step 5: Installing the Ground Wire (Optional) if your house plumbing is plastic, this step should be skipped

IMPORTANT: A copper or galvanized house cold water pipe is often used to ground electrical outlets in the home. Grounding protects you from electrical shock. The water filter housing may have broken this ground path. To restore connections install an 18" long, 6 gauge copper wire across the filter, clamped using 1/2"-1" bronze grounding clamps. Zinc clamps should not be used on copper plumbing.

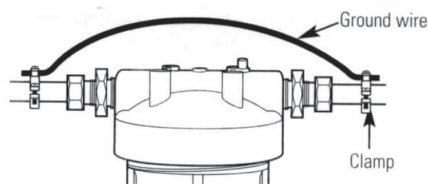

1. Clean copper pipe and ends of ground wire with emery paper. Bare wire is recommended. If insulated wire is used, it should be stripped 3/4" at each end before cleaning with emery paper.
2. Attach bronze clamps to copper pipe. Tighten screws.
3. Attach wire to clamps as shown. Tighten screws.

### Step 6: Put Cartridge into The Housing

1. Remove wrapping from new filter cartridge. Put cartridge into housing, make sure the housing **O-ring** is in place. Turn housing counter-clockwise to close. **DO NOT OVERTIGHTEN.**
2. Slowly turn on water supply.
3. Check entire system for leaks. If leaking, shut off water supply and tighten or reseal fittings.
4. After installation, flush the cartridge for 5 minutes, wait one hour, then flush again for 5 minutes before using the water.

## FILTER CARTRIDGE REPLACEMENT

You should change your filter cartridge when the water flow is noticeably reduced or at least every 6 to 12 months.

1. Turn off water to the filter. Water must be shut off from **Valve A** (and **Valve C** if it is installed). **See Fig. 1A**, Page 2
2. Turn on the faucet nearest to the filter housing to release pressure.
3. Unscrew the filter canister and discard used cartridge. Wash the filter canister with mild soap and water. Do not use harsh cleaners or hot water.
4. Inspect the filter canister O ring. Make sure it is lightly lubricated and completely seated in the groove. It is recommended that you replace the O ring when you replace the filter.
5. Place a new filter cartridge into the canister, make sure it is centered and completely seated on the bottom seal.
6. Reinstall the canister to its cap. Hand tightening is all that is required to seal the unit. You can use a wrench to slightly give the canister an additional  $1/2$  turn, but **DO NOT OVERTIGHTEN**.
7. Slowly turn on water to the filter by using the upstream shut-off valve (if there is one).
8. After installation, flush the cartridge for 5 minutes, wait one hour, then flush again for 5 minutes before using the water.

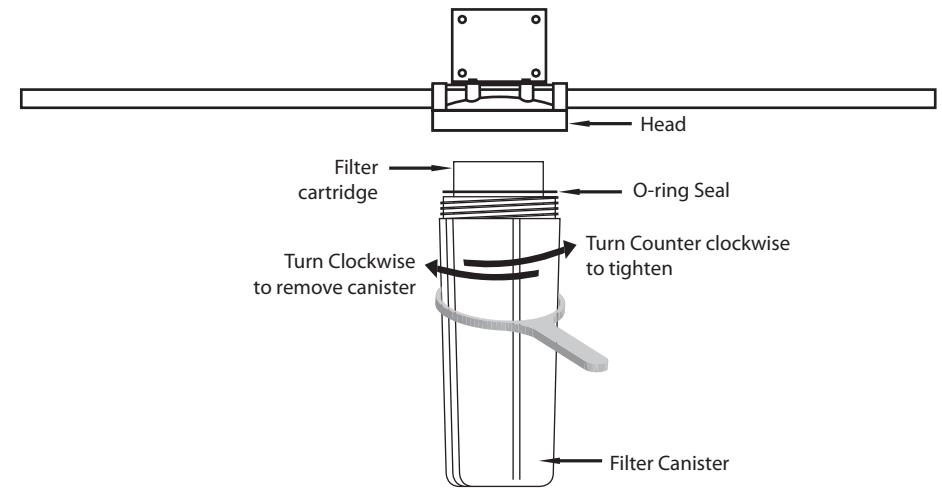

Fig 7

# LIMITED PRODUCT WARRANTY

## Scope

APEC takes pride in selling a superb line of products, including this 10" or 20" Whole House Water Filter ("Product"). As such, APEC expressly warrants to the original purchaser that, for a period of one (1) year from the date of purchase, the Product will be reasonably free of defects in materials and workmanship. Within that one (1) year period from the original purchase, APEC will, at its option, repair or replace the Product without charge, or refund the cost of the Product, if the Product fails or does not perform as warranted solely due to a manufacturing defect within the warranty period, subject to the limitations and exclusions set forth in this Limited Product Warranty. This Limited Product Warranty only applies when the Product is used, stored, handled, fabricated and/or installed in the manner recommended by APEC in the Installation Instruction & Owner's Manual ("Manual").

## Repair or Replacement

Repair or replacement during this one (1) year warranty shall include reasonable labor charges necessary to repair or replace the defective Product, but shall not include freight charges or any other local labor charges from third parties other than APEC, unless APEC expressly approves such charges in writing. During the entire one (1) year warranty, APEC's obligation to repair or replace shall further be limited to repair or replacement with the styles, models, products, colors, etc. of the Product that are available at the time of the repair or replacement, and shall be limited to the repair or replacement of only the specific Product that fails due to a manufacturing defect. Any repaired or replaced product shall also remain subject to the original one (1) year warranty from the date of the original purchase, and any repair or replacement shall not extend the original warranty period in any manner or start a new warranty period.

## Conditions of Validity of this Limited Product Warranty

Even though the Product has extremely high endurance for operating conditions such as pH, maximum TDS, temperature, and optimum water pressure, THIS LIMITED PRODUCT WARRANTY SHALL ONLY BE VALID IF:

1. The replaceable filters are changed and maintained on a regular basis as directed in the Manual. Moreover, depending on local water input water quality, regular maintenance may need to be increased.
2. The Product is operated within the confines of the following standard operating conditions:

	<b>Water Pressure</b>	<b>Water Temp.</b>
10" & 20" Whole House Water Filter	Max. 90 psi	Max. 100 F

Any information or suggestion by APEC with respect to the Product concerning applications, specifications or compliance with codes and standards is provided solely for your convenient reference and is made without any representation as to accuracy or suitability. You must verify and test the suitability of any information with respect to the Product for your specific application.

## Non-Covered Defects

THIS LIMITED PRODUCT WARRANTY DOES NOT COVER DEFECTS CAUSED BY:

1. Improper storage, installation, maintenance, handling, use and/or alterations of the Product, including, but not limited to, non-compliance with the installation, maintenance and standard operation conditions stated in the Manual and this Limited Product Warranty.
2. Unreasonable use, unintended use, or misuse of the Product for something other than its intended purpose.
3. Use of replacement parts, filters, or other accessories that are not sold or manufactured by APEC for use with this particular Product.
4. Damage not resulting from manufacturing defects that occur while the Product is in the original purchaser's possession.
5. Installation of the Product with known or visible manufacturing defects at the time of installation.
6. Damage caused by freezing, flood, fire or Act of God.



## CONDITIONS THAT RENDER THIS LIMITED PRODUCT WARRANTY VOID

THIS LIMITED PRODUCT WARRANTY SHALL BE VOID IF:

1. The Product is not operated in compliance with normal municipal water conditions for which the particular model of this Product is intended.
2. The person seeking to invoke the warranty is not the original purchaser. That is, this Limited Product Warranty only extends to original purchasers.
3. The Product is purchased used. That is, this Limited Product Warranty only covers new products.
4. The Product is purchased from someone other than APEC or one of APEC's authorized dealers. This is because, unless the Product was sold by APEC or one of its authorized dealers, APEC cannot verify or guarantee the integrity or authenticity of the Product.

## General Conditions

The warranties set forth herein are the only warranties made by APEC in connection with the product. APEC cannot and does not make any implied or express warranties with respect to the product, and disclaims all other warranties, including, but not limited to, any warranty of merchantability or fitness for a particular purpose. Products sold by APEC are sold only to the specifications specifically set forth by APEC in writing. Other than the limited product warranty set forth herein, APEC makes no other warranties, express or implied. APEC's sole obligation under this warranty shall be repair or replacement of a non-conforming product or parts of the product, or at the option of APEC, return of the product and a refund of the purchase price. Buyer assumes all risk whatsoever as to the result of the use of the product purchased, whether used singularly or in combination with any other products or substances.

No claim by the buyer/owner of any kind, including claims for indemnification, shall be greater in amount than the purchase price of the products in respect to which damages are claimed. In no event shall APEC be liable to buyer/owner in tort, contract or otherwise, for any special, indirect, incidental, consequential, reliance, statutory, special, punitive or exemplary damages, including, but not limited to, lost profits, loss of use, loss of time, inconvenience, damage to good will or reputation, or loss of data, even if advised of the possibility of such damages or such damages could have been reasonably foreseen, in connection with, arising out of, or as a result of, the sale, delivery, servicing, use or loss of use of the products sold hereunder, or for any liability of buyer to any third party with respect thereto.

## Obtaining Warranty Coverage or General Inquiries

If coverage is available, you may obtain coverage under this Limited Product Warranty by providing APEC with proof of original purchase, and that you are the original purchaser. For service under this Limited Product Warranty, you must notify APEC by phone at 1-800-880-4808, by email at [techsupport@freedrinkingwater.com](mailto:techsupport@freedrinkingwater.com), or in writing at 1320 S. Johnson Dr., City of Industry, CA 91745. In making the claim, please provide your name, address, phone number, a description of the product involved, and an explanation of the defect.





**Advanced Purification Engineering Corp.**

1320 S Johnson Drive  
City of Industry, CA 91745

*For questions or comments please visit our website at:*

**FreeDrinkingWater.com**

*For technical support contact us at:*

**Techsupport@freedrinkingwater.com**  
**1-800-880-4808**