



SPECIFICATIONS
VALENCIA™
 WALL MOUNT RANGE HOODS

HVI 2100 CERTIFIED 500 CFM/11.0 SONES @ 0.10" WG., 120 Volts, 3.8 amps, 60 hz.

Dimensions

Overall bottom projection - 19³/₄"
 Height (less chimney) - 9¹/₄"
 Available widths: 30" & 36"

Hood Body

All metal cold rolled or stainless steel, finished in powder coat or brushed stainless steel.

Motor

3 speed, permanently split capacitor motor. Rated 120 volts, 60 hz., 3.0 amps.

Lighting

Two - GU10 base, MR16, 50 watt halogen lights.

Ducting Options

Vertical ducting: 6" round duct adapter complete with back draft damper ensuring quiet operation.
 Ductless: Requires charcoal filter (not included).

Blower Wheel

Dual inlet, electronically balanced polymeric centrifugal blower wheel, 5¹/₄" width 59 paddles.

Mounting

Wall mounted. Install 24" to 36" from cooking surface.

Filters

Grease Filter: Dishwasher safe, BCGF-01 (included).
 Charcoal Filter: BCCF-02 (not included).

Available Finishes

White, Black & Stainless Steel.

Barcelona®
 Collection

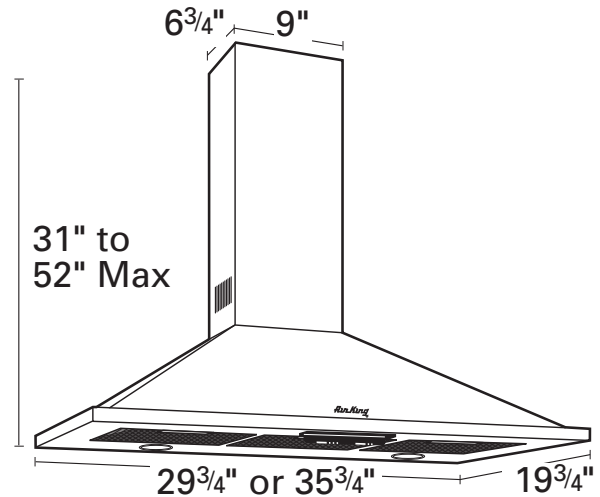

EXPANDED PERFORMANCE

	Static Pressure (inches of w.g.)								Sones @ .1 SP	Fan Speed RPM	Power Watts
	0	0.1	0.125	0.25	0.375	0.5	0.75	1.0			
Air Flow - CFM	508	500	498	488	477	465	440	413	11.0	2500	450

PROJECT				ARCHITECT					
LOCATION				ENGINEER					
CONTRACTOR				SUBMITTED BY			DATE		
FAN NUMBER	MODEL NUMBER	CFM	IN W.C.	RPM	WATTS	AMPS	SONES	QTY	OPTIONAL EQUIPMENT & REMARKS



U.S.: 820 Lincoln Avenue
 West Chester, Pennsylvania 19380-4466
 Tel: (610) 692-7400 • 877-304-3785
 Fax: (610) 696-8048

Canada: 8 Edvac Drive
 Brampton, Ontario L6S 5P2
 Tel: (905) 456-2033
 Fax: (905) 456-1015