

HOME DECORATORS COLLECTION

SK18694 ARTISAN COFFEE TABLE 18"Hx47.5"Wx23.6"D

INV#92384

ASSEMBLY INSTRUCTIONS

Made In China

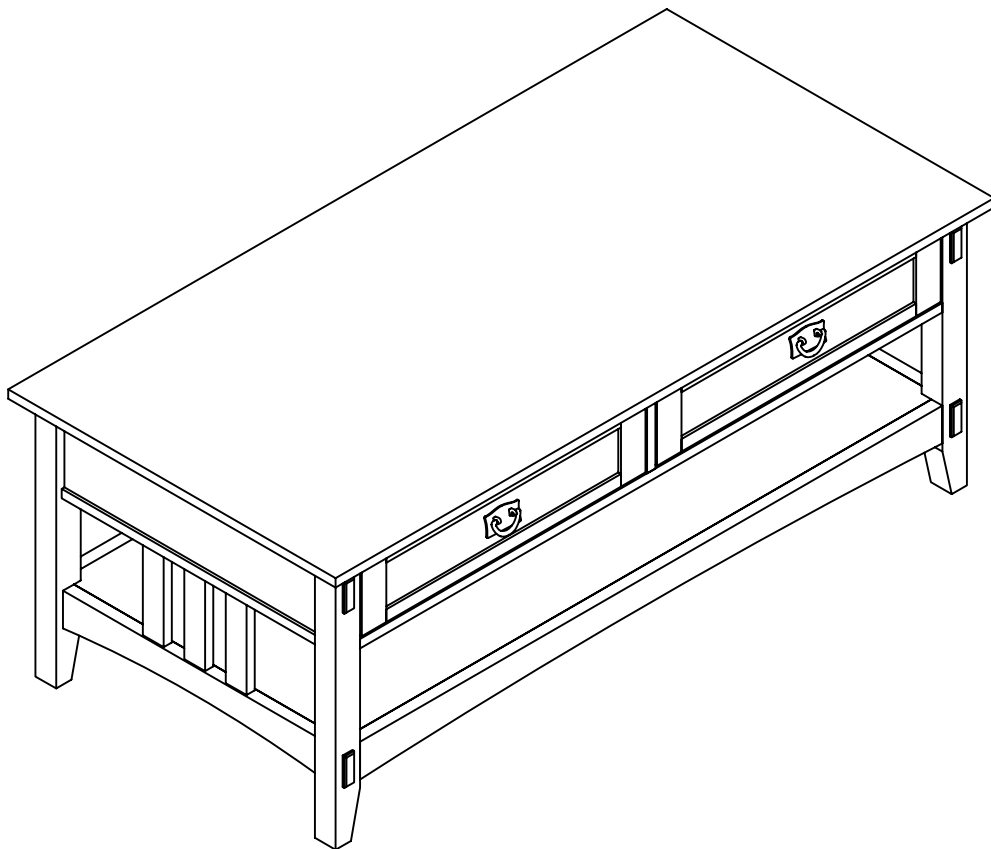

Thank you for purchasing this quality product. Be sure to check all packing material carefully for small parts, which may have come loose inside the carton during shipment. Count all parts and material hardware, then compare with parts list to be sure all parts are present. If any parts are missing or damaged, phone, fax, or mail to our Customer Service Department for efficient and speedy service. Please indicate the model number and code letter of part(s) needed.

IMPORTANT NOTE: Follow instructions listed below in proper sequence as numbered to assure fast, easy and correct assembly.

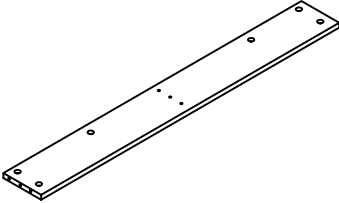
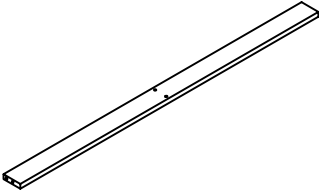
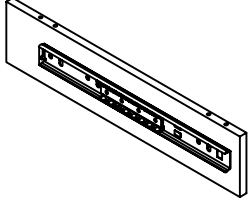
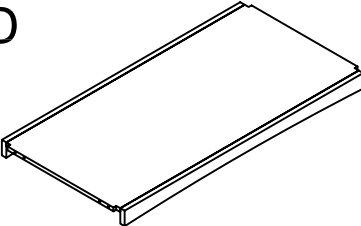
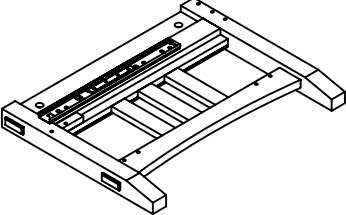
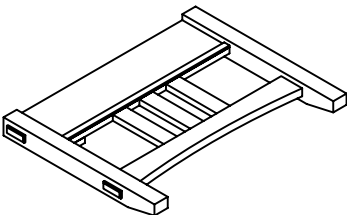
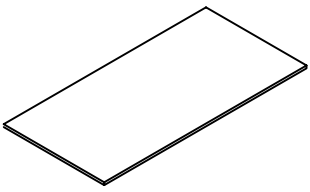
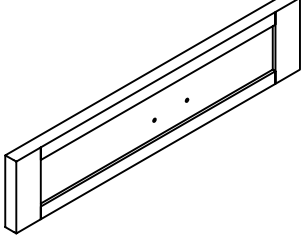
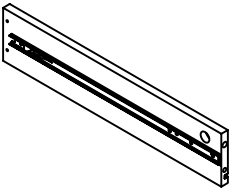
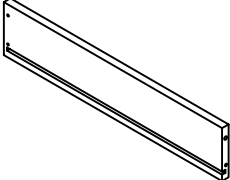
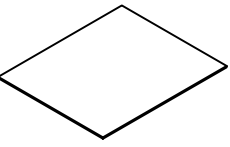
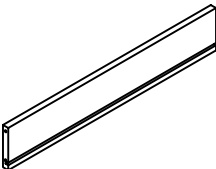
PARTS LIST		
A 	B 	C 
BACK PANEL-1PC	FRONT CROSS BAR-1PC	PARTITION-1PC
D 	E 	F 
BOTTOM PANEL-1PC	LEFT SIDE PANEL-1PC	RIGHT SIDE PANEL-1PC
G 	H 	I 
TOP PANEL-1PC	DRAWER FRONT PANEL-2PCS	DRAWER LEFT SIDE PANEL-2PCS
J 	K 	L 
DRAWER RIGHT SIDE PANEL-2PCS	DRAWER BOTTOM PANEL-2PCS	DRAWER BACK PANEL-2PCS

a



WOOD DOWEL-21PCS

b

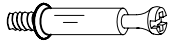

CAM LOCK BOLT-23PCS

c



CAM LOCK-23PCS

d



1" FLAT HEAD SCREW-9PCS

e



SHORT PLASTIC COVER-4PCS

f

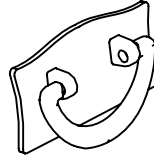

HANDLE-2PCS

g



HANDLE BOLT-4PCS

NOTE:THE SURFACE WITH THE STICKER IS THE BACK SIDE

HOW TO SEPARATE GLIDES

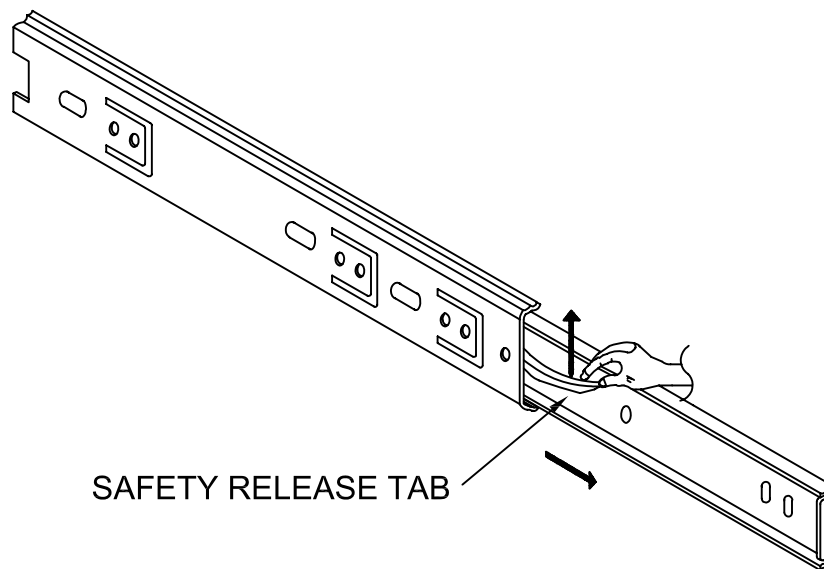

PRIOR TO ASSEMBLY, WE SUGGEST SEPARATING THE INNER GLIDES FROM THE OUTER-GLIDES, SIMPLY PULL THE LEFT/RIGHT INNER GLIDES FROM THE OUTER GLIDES EXPOSING A SMALL BLACK SAFETY RELEASE TAB, BY PUSHING THE SAFETY RELEASE TAB. YOU WILL BE ABLE TO SEPARATE THE GLIDES.

NOTE: • UPON OPENING, THOROUGHLY CLEAN ALL WOOD SURFACES TO REMOVE DUST AND DIRT THAT MAY HAVE SETTLED ONTO THE FINISH DURING SHIPMENT. IN ORDER TO PREVENT DAMAGE DURING ASSEMBLY. PLEASE ASSEMBLE THIS ITEM WITH AT LEAST TWO PEOPLE.

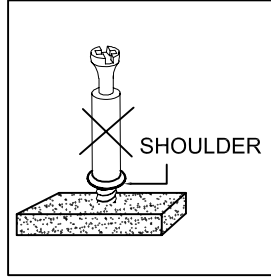
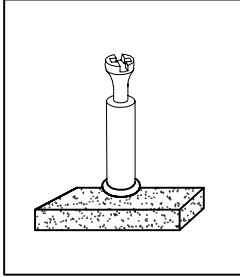

NOTE: TURN THE CAM-BOLT SCREWS UNTIL THEY ARE TIGHT, THE SHOULDER SHOULD BE AGAINST THE SURFACE OF THE PART.

HOW TO USE THE CAM-TOOL

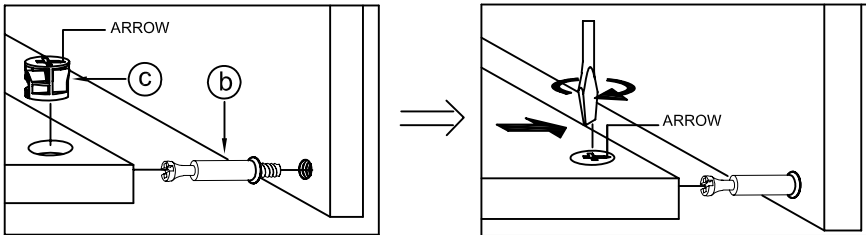

NOTE: • THE ARROWS ON THE HIDDEN CAM-LOCKS SHOULD POINT TO THE CAM-BOLTS.

FIG 1

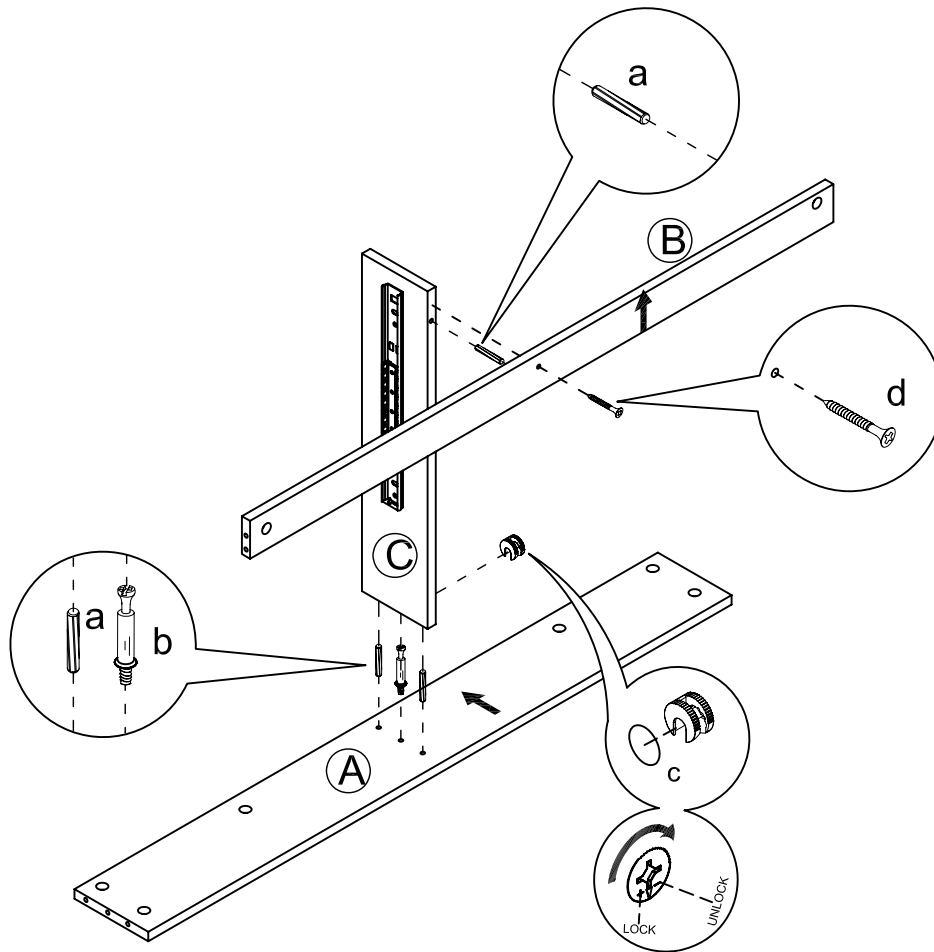

- INSTALL THE WOOD DOWEL (a) AND THE CAM LOCK BOLT (b) INTO THE BACK PANEL (A) .
- JOIN THE BACK PANEL (A) TO THE PARTITION (C) BY USING THE WOOD DOWEL (a) FIRST.
- ONCE JOINED, TIGHTEN CAM LOCK (c) ONTO CAM LOCK BOLT (b) USING PRE-DRILLED HOLES.
- INSTALL THE WOOD DOWEL (a) INTO THE FRONT CROSS BAR (B) .
- JOIN THE FRONT CROSS BAR (B) TO THE ASSEMBLED PART BY USING THE WOOD DOWEL (a) FIRST.
- ONCE JOINED, TIGHTEN THE FRONT CROSS BAR (B) TO THE ASSEMBLED PART BY USING 1" FLAT HEAD SCREW (d).

FIG 2

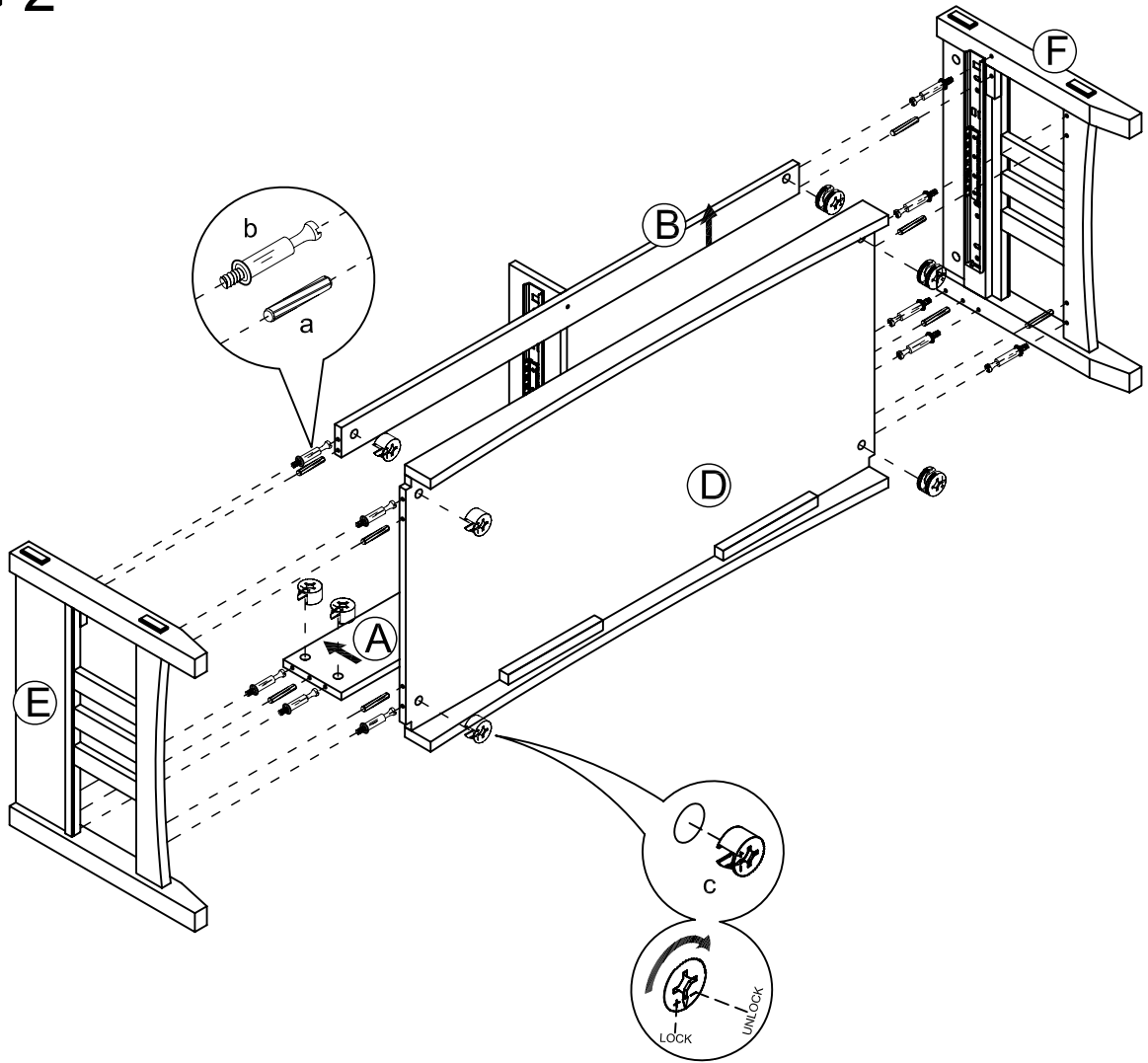

- INSTALL THE WOOD DOWEL (a) AND THE CAM LOCK BOLT (b) INTO THE LEFT SIDE PANEL (E) AND THE RIGHT SIDE PANEL (F) .
- JOIN THE LEFT SIDE PANEL (E) AND THE RIGHT SIDE PANEL (F) TO THE ASSEMBLED PART AND THE BOTTOM (D) BY USING THE WOOD DOWEL (a) FIRST.
- ONCE JOINED, TIGHTEN CAM LOCK (c) ONTO CAM LOCK BOLT (b) USING PRE-DRILLED HOLES.

FIG 3

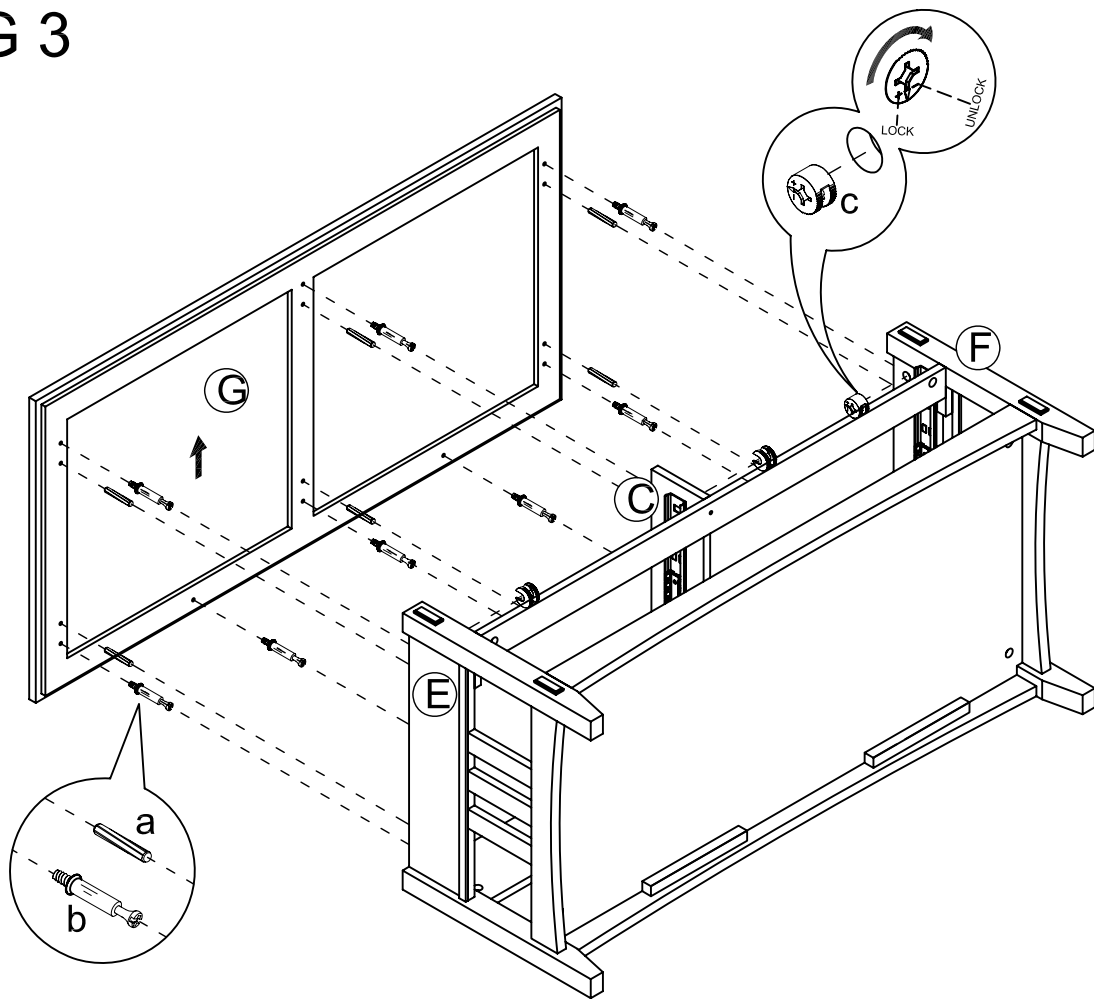

- INSTALL THE WOOD DOWEL (a) AND THE CAM LOCK BOLT (b) INTO THE TOP PANEL (G) .
- JOIN THE TOP PANEL (G) TO THE ASSEMBLED PART BY USING THE WOOD DOWEL (a) FIRST.
- ONCE JOINED, TIGHTEN CAM LOCK (c) ONTO CAM LOCK BOLT (b) USING PRE-DRILLED HOLES.

FIG 4

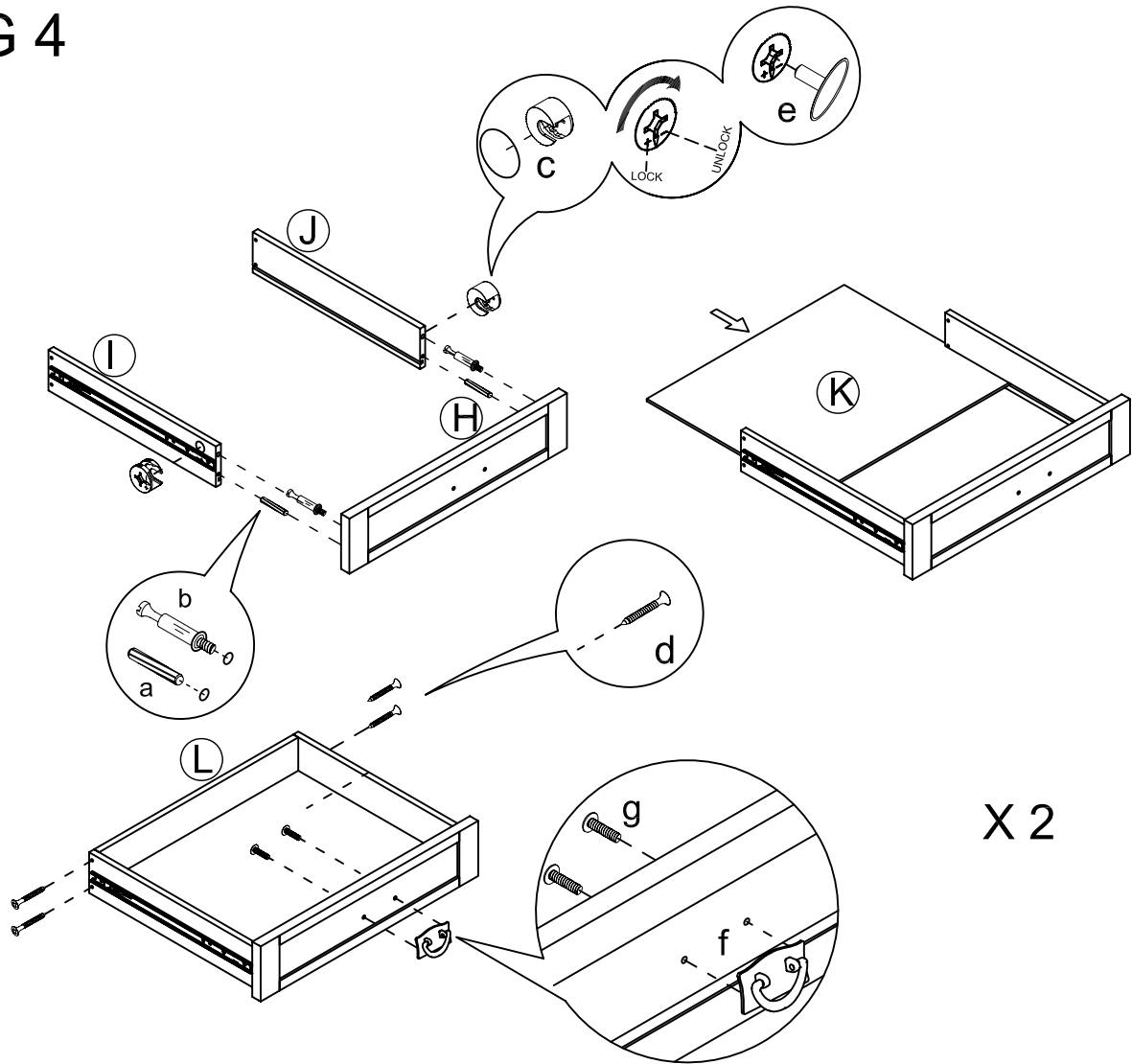

- INSTALL THE WOOD DOWEL (a) AND THE CAM LOCK BOLT (b) INTO THE DRAWER FRONT PANEL (H).
- JOIN THE DRAWER LEFT SIDE PANEL (I) AND THE DRAWER RIGHT SIDE PANEL (J) TO THE DRAWER FRONT PANEL (H).
- ONCE JOINED, TIGHTEN CAM LOCK (c) ONTO CAM LOCK BOLT (b) USING PRE-DRILLED HOLES.
- COVER CAM HOLES WITH THE SHORT PLASTIC COVER (e).
- SLIDE THE DRAWER BOTTOM PANEL (K) INTO THE GROOVES ON THE DRAWER LEFT SIDE PANEL (I) AND THE DRAWER RIGHT SIDE PANEL (J).
- JOIN THE DRAWER BACK PANEL (L) TO THE ASSEMBLED DRAWER PART AND TIGHTEN THE DRAWER BACK PANEL (L) BY USING THE 1" FLAT HEAD SCREW (d) THROUGH THE PRE-DRILLED HOLES ON THE SIDE PANELS.
- TIGHTEN THE HANDLE (f) TO THE DRAWER FRONT PANEL (H) BY USING THE HANDLE BOLT (g).
- REPEAT STEPS ABOVE FOR THE 2ND DRAWER.

FIG 5

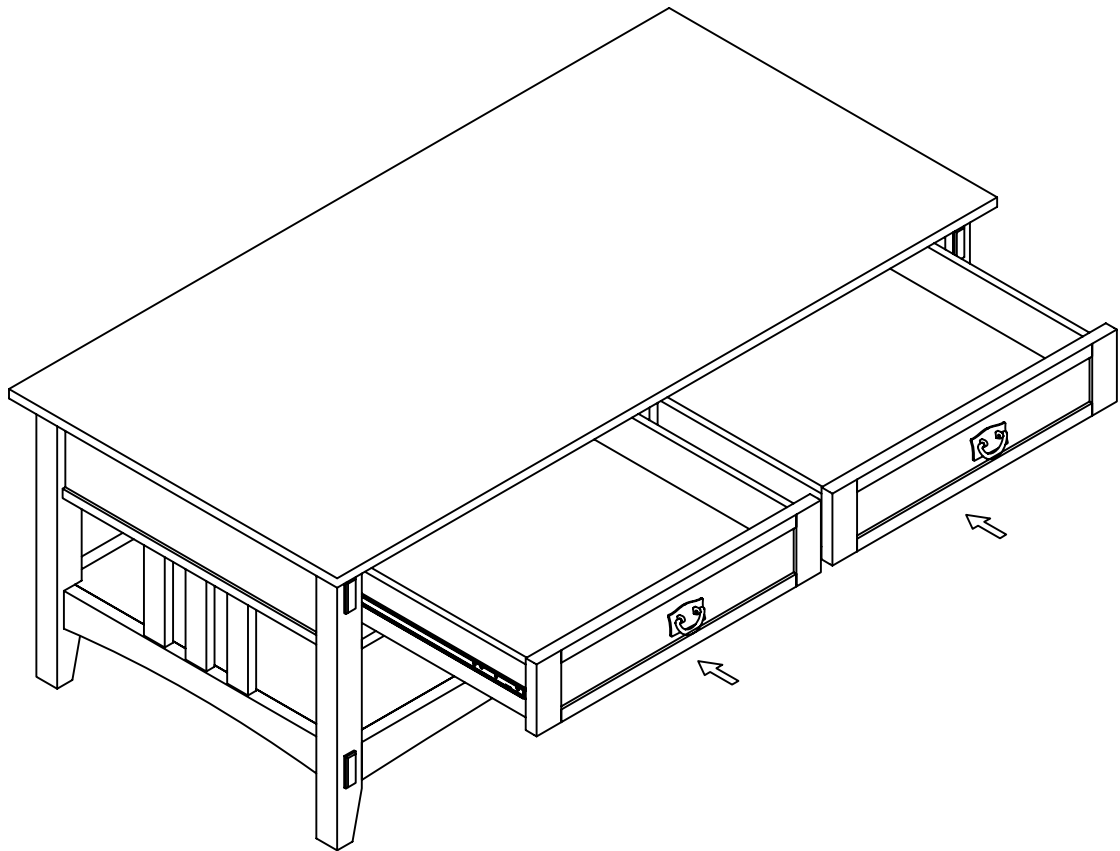

- INSERT DRAWERS INTO THE ASSEMBLED UNIT.