



All Weather Furnishings

Model: PBB48

- (2) Leg assembly - RH/LH
- (1) Seat
- (1) Brace
- (1) Hardware pack

TOOLS NEEDED

- 7/16 socket drive
- 1/2 socket drive

Step 1

Lay seat assembly upside down.
Attach leg assemblies to seat assembly
using (8) 2-1/2" Hex bolts and 5/16" washers

Note: Side frames attach to the
inside of the seat frame.

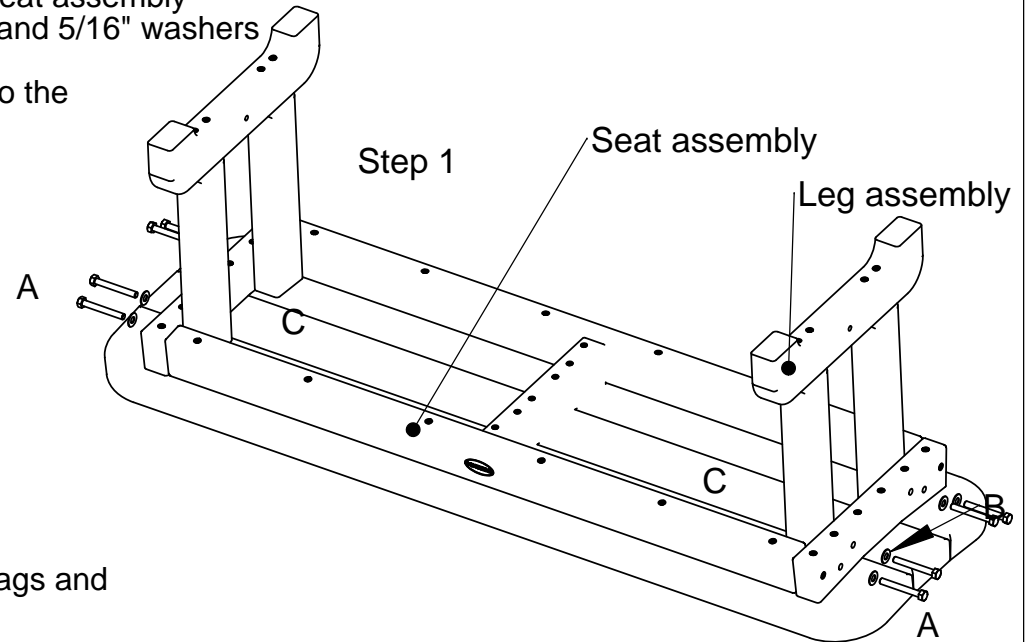

Step 2

Attach brace using (2) 3" lags and
1/4" washers

*Tighten all bolts at this time

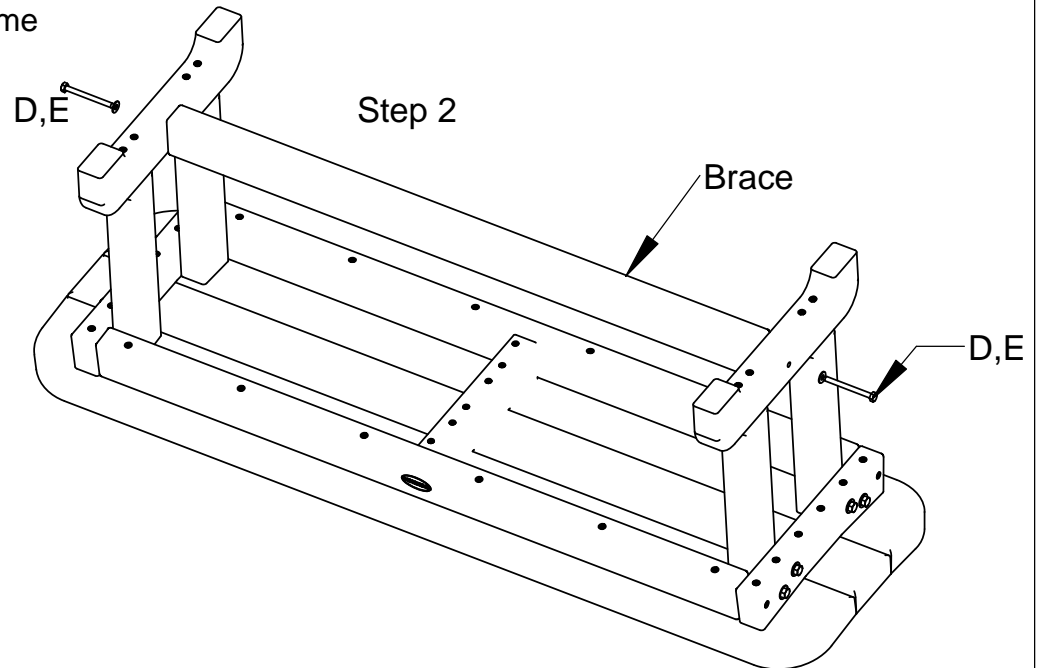

Qty.	Description
8	A - 5/16-18 X 2 1/2 HEX CAP SCREW
8	B - 5/16 X 3/4 OD FLAT WASHER
2	C - 1/4 X 3 HEX LAG SCREW
2	E - 1/4 FLAT WASHER

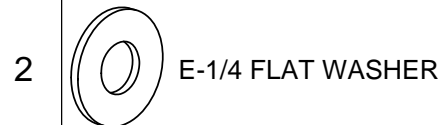
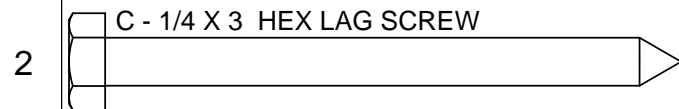
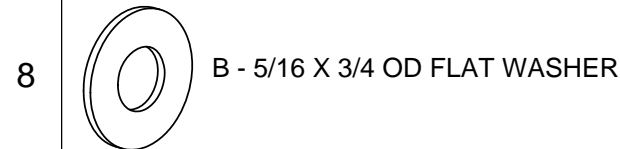
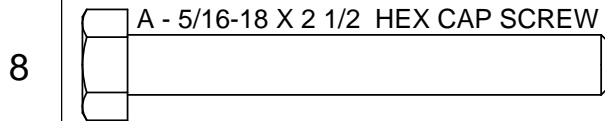

POLYWOOD®

All Weather Furnishings

Join the POLYWOOD® Community

Share in the love of outdoor living, recycling, and more...



POLYWOOD



@POLYWOODINC



youtube.com/polywood



POLY-WORLD
Blog



POLYWOOD



To view our full warranty, please visit the warranty page on our website at polywoodinc.com/resources.

If you have questions or concerns regarding assembly instructions or missing parts, please contact us at (877) 457-3284 or email support@polywoodinc.com