

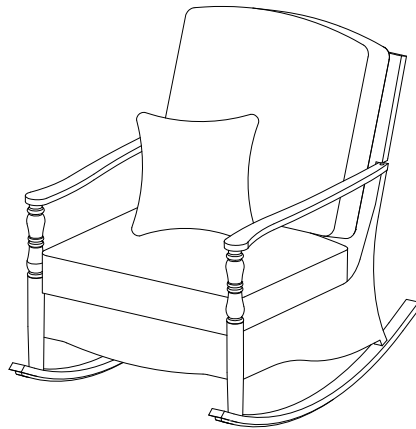

Item #699 188
Model #D13106-R

USE AND CARE GUIDE

BOLINGBROOK ROCKING CHAIR



Questions, problems, missing parts? Before returning to the store,
call Hampton Bay Customer Service
8 a.m. - 7 p.m., EST, Monday-Friday
9 a.m. - 6 p.m. EST, Saturday

1-855-HD-HAMPTON

HAMPTONBAY.COM

THANK YOU

We appreciate the trust and confidence you have placed in Hampton Bay through the purchase of this rocking chair. We strive to continually create quality products designed to enhance your home. Visit us online to see our full line of products available for your home improvement needs. Thank you for choosing Hampton Bay!

Table of Contents

Table of Contents.....	2	Hardware Included.....	3
Warranty.....	2	Rocking Chair Package Contents.....	4
What is Covered.....	2	Assembly	5
What is Not Covered	2	Care and Cleaning	6
Pre-Assembly	3		
Planning assembly.....	3		

Warranty

THIS IS A RESIDENTIAL WARRANTY ONLY AND THIS WARRANTY DOES NOT APPLY TO COMMERCIAL USE

5 YEAR FRAME LIMITED WARRANTY/2 YEAR RESIN WEAVE AND FABRIC LIMITED WARRANTY

WHAT IS COVERED

We warrant the frame to be free of manufacturing defects to the original purchaser for five years and the resin weave and fabric for two years.

WHAT IS NOT COVERED

It remains the customer's responsibility for freight and packaging charges to and from our service center.

This warranty does not cover commercial use, hardware, acts of nature, fire, freezing, and abusive use.

In addition, purchased parts are not covered under this warranty. We reserve the right to make substitutions with similar merchandise, if the model in question is no longer in production.

For a copy of our full limited warranty, please contact our customer service team below.

Contact the Customer Service Team at 1-855-HD-HAMPTON or visit www.hamptonbay.com.

Pre-assembly

PLANNING ASSEMBLY

Please read this entire instruction manual prior to assembly.

Identify all parts packed in the carton against the parts list. Remove all protective materials and place the parts on a non-abrasive surface to avoid scratching.



NOTE: More than one person may be required to complete the assembly of this product.

HARDWARE INCLUDED



NOTE: Tools not shown to actual size.

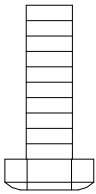

_AA

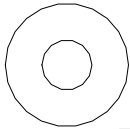

_BB



_CC



_DD

Part	Description	Quantity
AA	M6X20mm Hex bolt	8
BB	M6 washer	8
CC	M6 Hex bolt cap	8
DD	M6-M8 Hex Wrench	1

Pre-assembly (continued)

ROCKING CHAIR PACKAGE CONTENTS

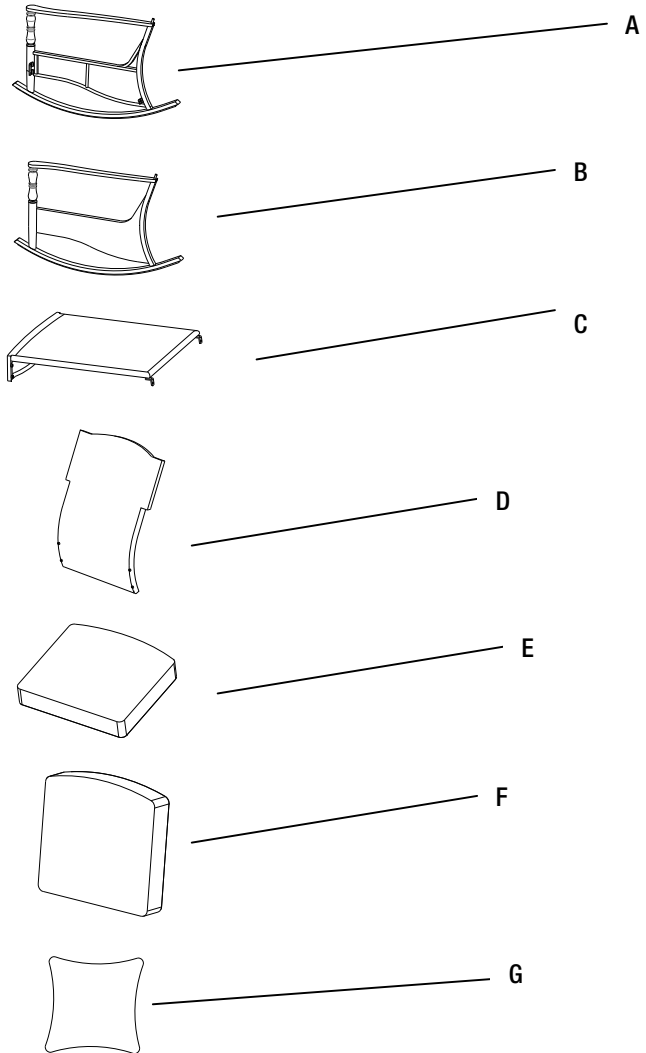

Part	Description	Quantity
A	Left arm panel	1
B	Right arm panel	1
C	Seat panel	1
D	Chair back	1
E	Seat cushion	1
F	Back cushion	1
G	Toss pillow	1

Assembly

1 Attaching the arm panels

- With the assistance of another person, insert the chair back (D) into left arm panel (A) and right arm panel (B) using M6 hex bolts (AA) and M6 washer (BB) attach arm panels (A) and (B) with back.
- Tighten all M6 hex bolts (AA) with the M6 wrench (DD).
- Attach the bolt caps (CC).



NOTE: Please ensure all M6 hex bolts (AA) are aligned and assembled correctly. Fully tighten the bolts.

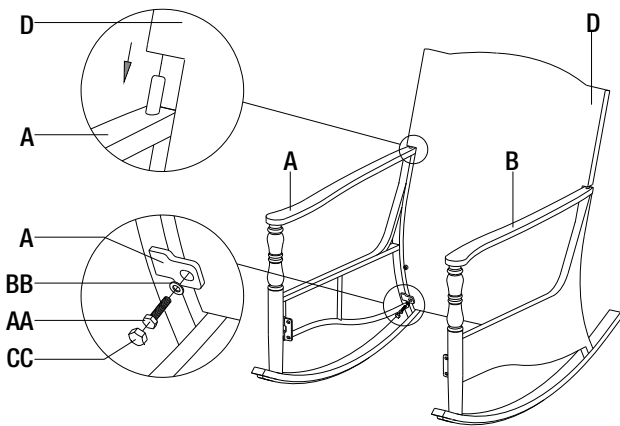

3 Adding the cushions

- Place the seat cushion (E), back cushion (F) and toss pillow (G) on the rocking chair

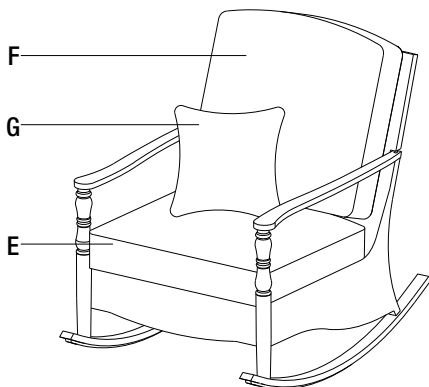

2 Attaching the seat panel and back panel

- Attach the seat panel (C) to chair frame and chair back (D) using M6 hex bolts (AA) and M6 washer (BB).
- Tighten all M6 hex bolts (AA) with the M6 wrench (DD).
- Attach the bolt caps (CC).

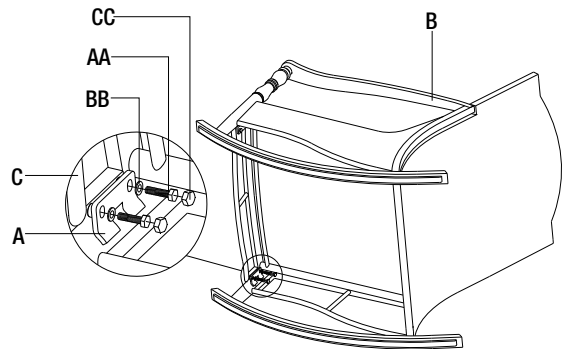
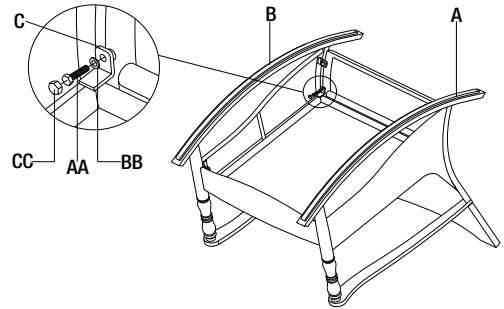

Care and Cleaning

- Do not allow water to build up in the frames. This will cause corrosion and possible freezing damage in cold climates.
- Use a mild soap and water for normal cleaning. Do not use janitorial or alcohol based cleaners. Some cleaners may be marked as natural, but some ingredients may cause discoloration or have an adverse reaction to your finish.
- Rinse with clean water and dry with a soft, absorbent cloth towel.
- Treat frames with a liquid wax for maximum protection against UV rays and/or salty, damp air.



Questions, problems, missing parts? Before returning to the store,
call Hampton Bay Customer Service
8 a.m. - 7 p.m., EST, Monday-Friday
9 a.m. - 6 p.m. EST, Saturday

1-855-HD-HAMPTON

HAMPTONBAY.COM

Retain this manual for future use.