

WESLO[®] pursuit CT 2.4

www.weslo.com

Model No. WLEX81214.0

Serial No. _____

Write the serial number in the space above for reference.

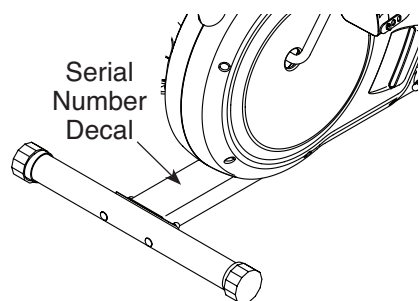

ACTIVATE YOUR WARRANTY

To register your product and activate your warranty today, go to www.wesloservice.com/registration.

CUSTOMER CARE

For service at any time, go to www.wesloservice.com.

Or call 1-866-699-3756
Mon.–Fri. 6 a.m.–6 p.m. MT
Sat. 8 a.m.–12 p.m. MT

Please do not contact the store.

⚠ CAUTION

Read all precautions and instructions in this manual before using this equipment. Keep this manual for future reference.

USER'S MANUAL

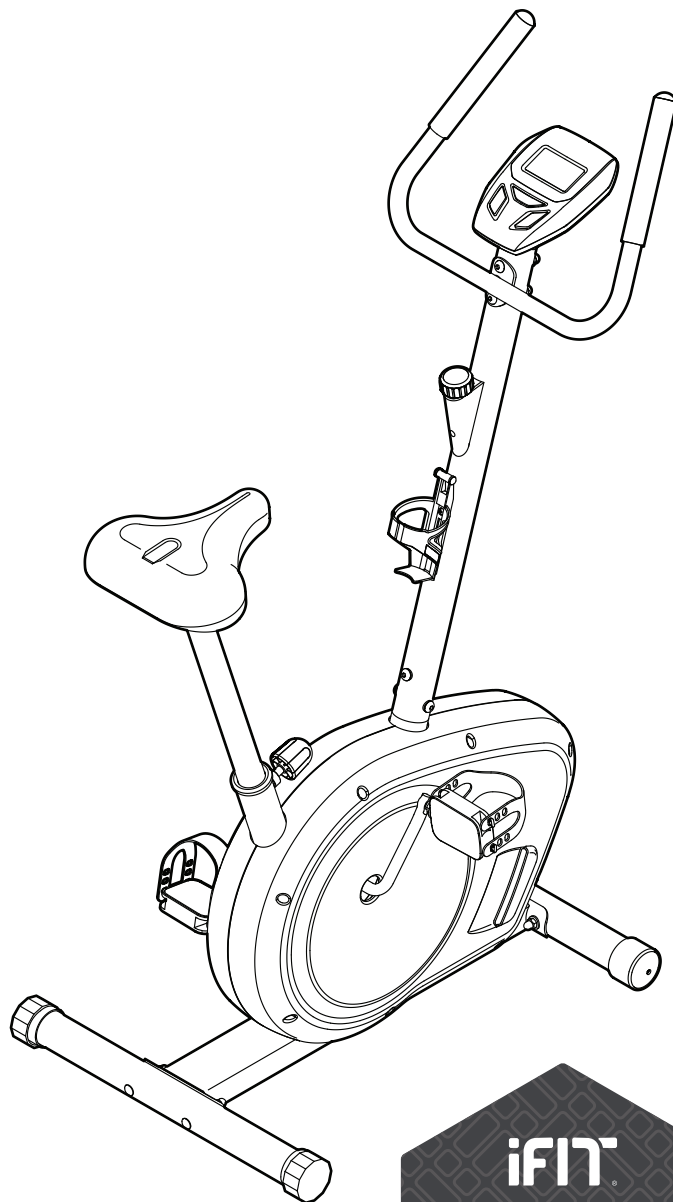

TABLE OF CONTENTS

WARNING DECAL PLACEMENT 2

IMPORTANT PRECAUTIONS 3

BEFORE YOU BEGIN 5

PART IDENTIFICATION CHART 6

ASSEMBLY 7

HOW TO USE THE EXERCISE BIKE 14

FCC INFORMATION 17

MAINTENANCE AND TROUBLESHOOTING 18

EXERCISE GUIDELINES 20

PART LIST 22

EXPLODED DRAWING 23

ORDERING REPLACEMENT PARTS Back Cover

LIMITED WARRANTY Back Cover

WARNING DECAL PLACEMENT

This drawing shows the location(s) of the warning decal(s).
If a decal is missing or illegible, see the front cover of this manual and request a free replacement decal.
Apply the decal in the location shown. Note: The decal(s) may not be shown at actual size.

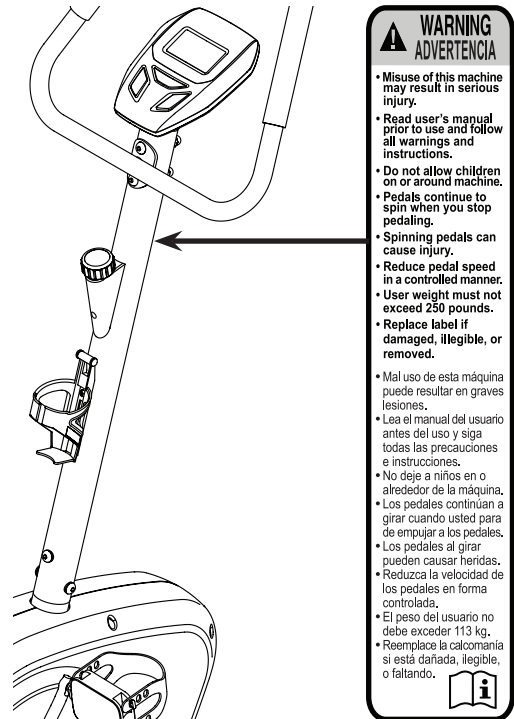

IMPORTANT PRECAUTIONS

⚠ WARNING: To reduce the risk of serious injury, read all important precautions and instructions in this manual and all warnings on your exercise bike before using your exercise bike. ICON assumes no responsibility for personal injury or property damage sustained by or through the use of this product.

1. It is the responsibility of the owner to ensure that all users of the exercise bike are adequately informed of all precautions.
2. Before beginning any exercise program, consult your physician. This is especially important for persons over age 35 or persons with pre-existing health problems.
3. Use the exercise bike only as described in this manual.
4. The exercise bike is intended for home use only. Do not use the exercise bike in a commercial, rental, or institutional setting.
5. Keep the exercise bike indoors, away from moisture and dust. Do not put the exercise bike in a garage or covered patio, or near water.
6. Place the exercise bike on a level surface, with a mat beneath it to protect the floor or carpet. Make sure that there is at least 2 ft. (0.6 m) of clearance around the exercise bike.
7. Inspect and properly tighten all parts regularly. Replace any worn parts immediately.
8. Keep children under age 12 and pets away from the exercise bike at all times.
9. Wear appropriate clothes while exercising; do not wear loose clothes that could become caught on the exercise bike. Always wear athletic shoes for foot protection.
10. The exercise bike should not be used by persons weighing more than 250 lbs. (113 kg).
11. Be careful when mounting and dismounting the exercise bike.
12. Always keep your back straight while using the exercise bike; do not arch your back.
13. The exercise bike does not have a freewheel; the pedals will continue to move until the flywheel stops. Reduce your pedaling speed in a controlled way.
14. Over exercising may result in serious injury or death. If you feel faint, if you become short of breath, or if you experience pain while exercising, stop immediately and cool down.

PROTECT

YOUR FITNESS EQUIPMENT
WITH AN EXTENDED SERVICE PLAN

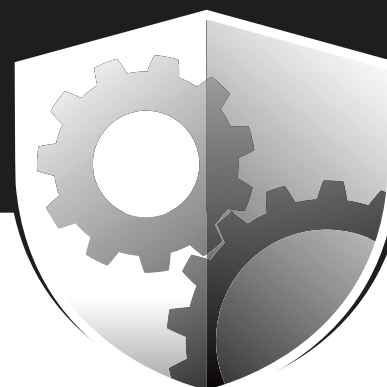

Your new fitness equipment is not an ordinary purchase; it is an investment in your health and well being for years to come.

As the leading provider of manufacturer's extended service plans, ICON strives to protect your equipment and your future.

Please review the following service plans and find one that best fits your needs.

PREVENTIVE MAINTENANCE SERVICE PLANS

Equipment Price	3-Year Plan	5-Year Plan
\$0.00 to \$1000.00	\$199.99	\$289.99
\$1001.00 to \$1500.00	\$259.99	\$379.99
\$1501.00 to \$2500.00	\$339.99	\$489.99
(Bikes/Systems Only) \$0.00 to \$2500.00	\$139.99	NA

Features:

- Includes an annual preventive maintenance and performance check at your convenience
- Unlimited in-home repairs; no shipping required
- Covers parts and labor on all manufacturer's defects, as well as wear and tear on parts
- Up to 5 years of coverage available

STANDARD SERVICE PLANS

Equipment Price	1-Year Plan	2-Year Plan	3-Year Plan
\$0.00 to \$300.00	\$29.99	\$39.99	\$59.99
\$301.00 to \$1000.00	\$89.99	\$119.99	\$149.99
\$1001.00 to \$2000.00	\$109.99	\$139.99	\$179.99
\$2001.00 to \$3000.00	\$179.99	\$209.99	\$239.99

Features:

- Unlimited in-home repairs; no shipping required
- Covers parts and labor on all manufacturer's defects, as well as wear and tear on parts
- Up to 3 years of coverage available

To protect your fitness equipment today, please
call Customer Care at **1-800-677-3838.**
Or, visit us online at **www.utserv.com.**



BEFORE YOU BEGIN

Thank you for selecting the new WESLO® PURSUIT CT 2.4 exercise bike. Cycling is an effective exercise for increasing cardiovascular fitness, building endurance, and toning the body. The PURSUIT CT 2.4 exercise bike provides a selection of features designed to make your workouts at home more effective and enjoyable.

For your benefit, read this manual carefully before you use the exercise bike. If you have questions after

reading this manual, please see the front cover of this manual. To help us assist you, note the product model number and serial number before contacting us. The model number and the location of the serial number decal are shown on the front cover of this manual.

Before reading further, please review the drawing below and familiarize yourself with the labeled parts.

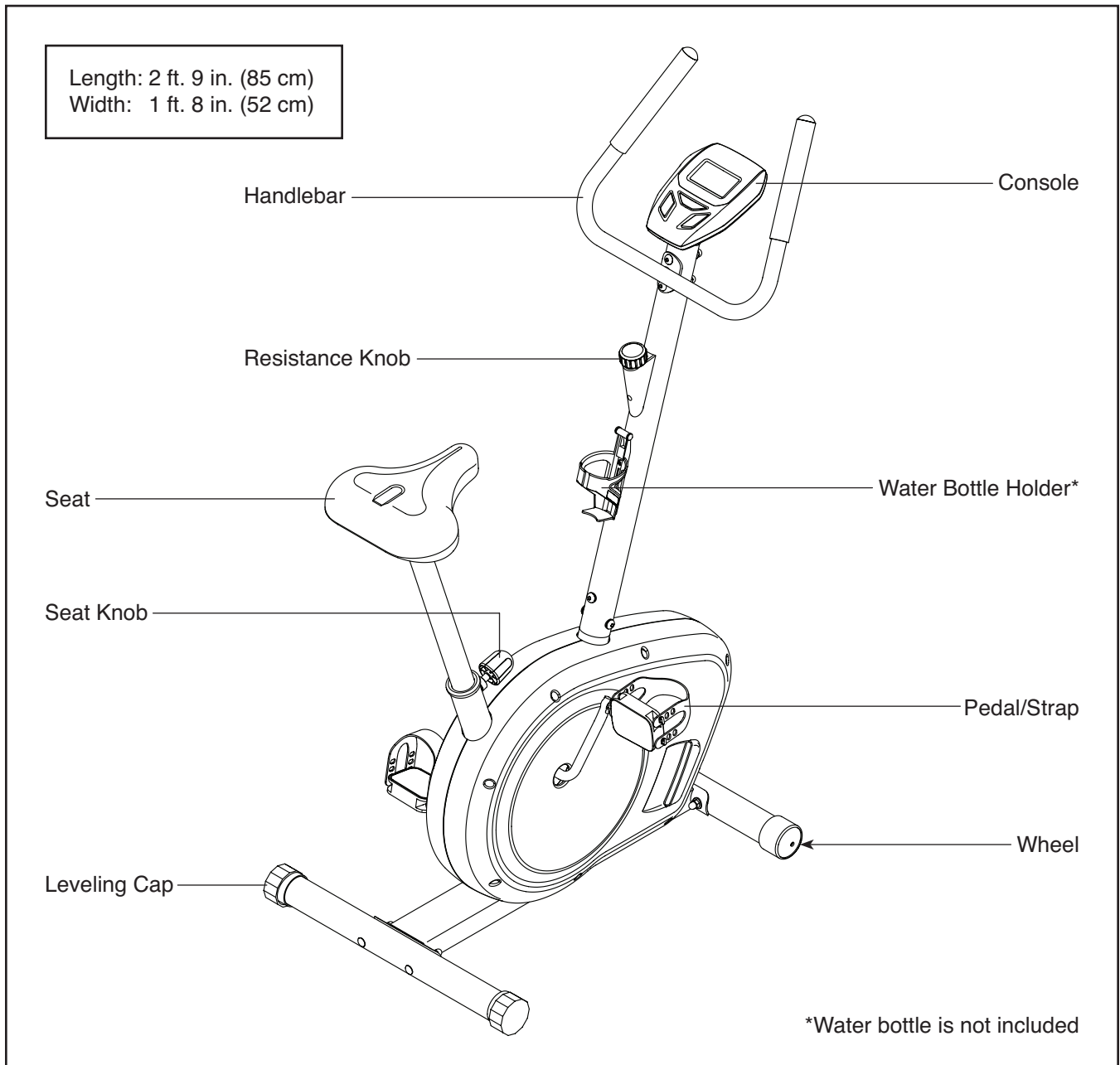

PART IDENTIFICATION CHART

Use the drawings below to identify the small parts needed for assembly. The number in parentheses below each drawing is the key number of the part, from the PART LIST near the end of this manual. The number following the key number is the quantity needed for assembly. **Note: If a part is not in the hardware kit, check to see if it has been preassembled. Extra parts may be included.**

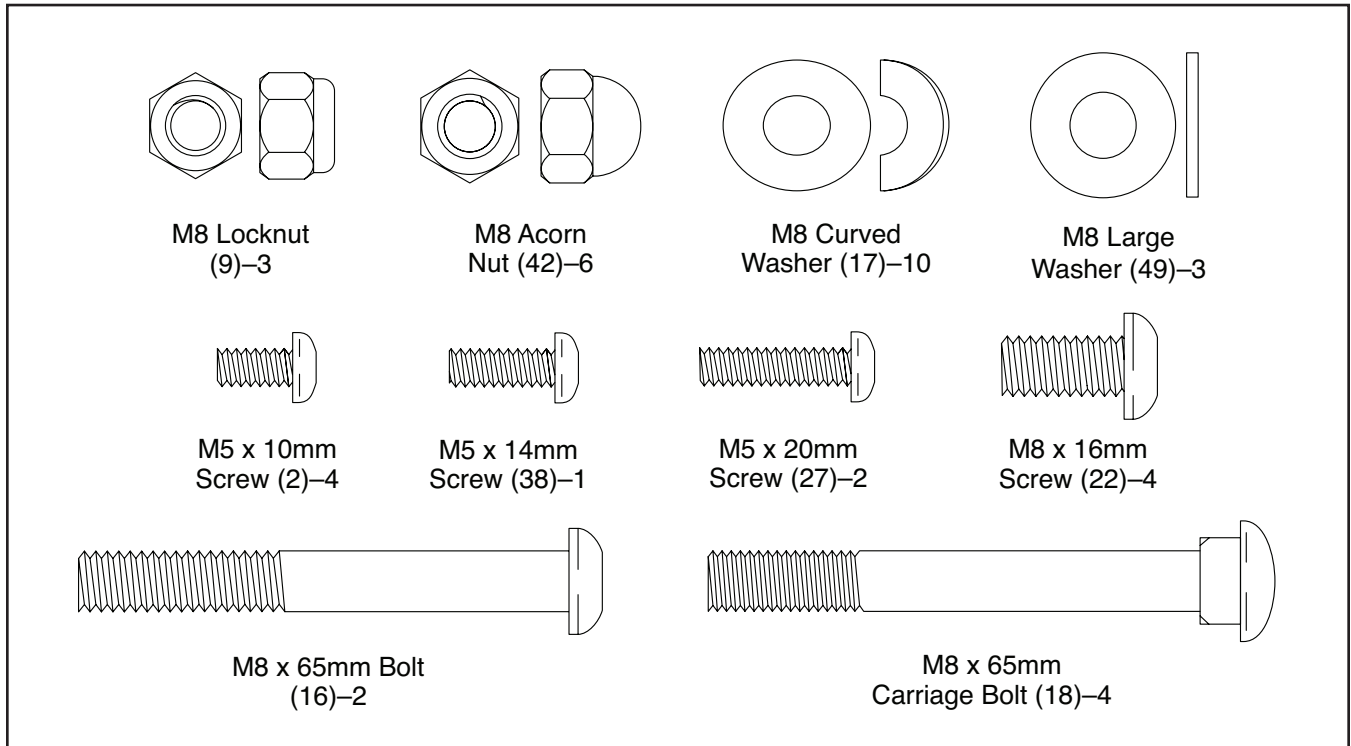

ASSEMBLY

- To hire an authorized service technician to assemble this product, call 1-800-445-2480.
- Assembly requires two persons.
- Place all parts in a cleared area and remove the packing materials. Do not dispose of the packing materials until you finish all assembly steps.
- To identify small parts, see page 6.
- Left parts are marked “L” or “Left” and right parts are marked “R” or “Right.”

- In addition to the included tool(s), assembly requires the following tools:

one Phillips screwdriver

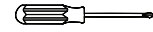

one adjustable wrench



one pair of pliers



Assembly may be easier if you have a set of wrenches. To avoid damaging parts, do not use power tools.

1. **Go to www.wesloservice.com/registration on your computer and register your product.**

- activates your warranty
- saves you time if you ever need to contact Customer Care
- allows us to notify you of upgrades and offers

Note: If you do not have Internet access, call Customer Care (see the front cover of this manual) and register your product.

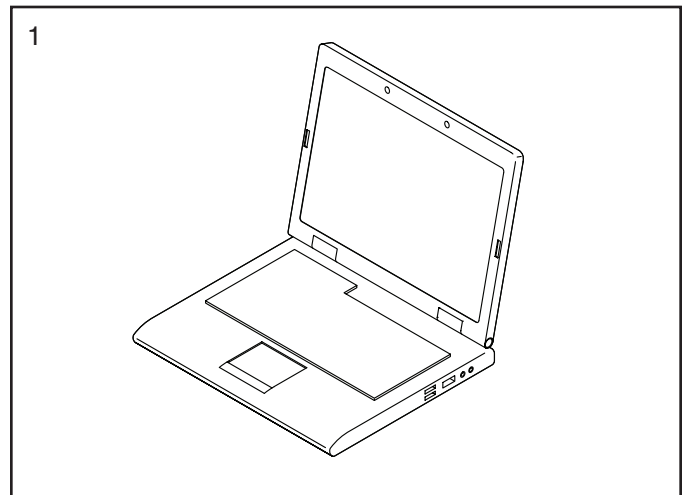

2. Identify the Rear Stabilizer (39), which has Leveling Caps (40).

Attach the Rear Stabilizer (39) to the Frame (23) with two M8 x 65mm Carriage Bolts (18), two M8 Curved Washers (17), and two M8 Acorn Nuts (42); **insert both Carriage Bolts, and then tighten the Acorn Nuts.**

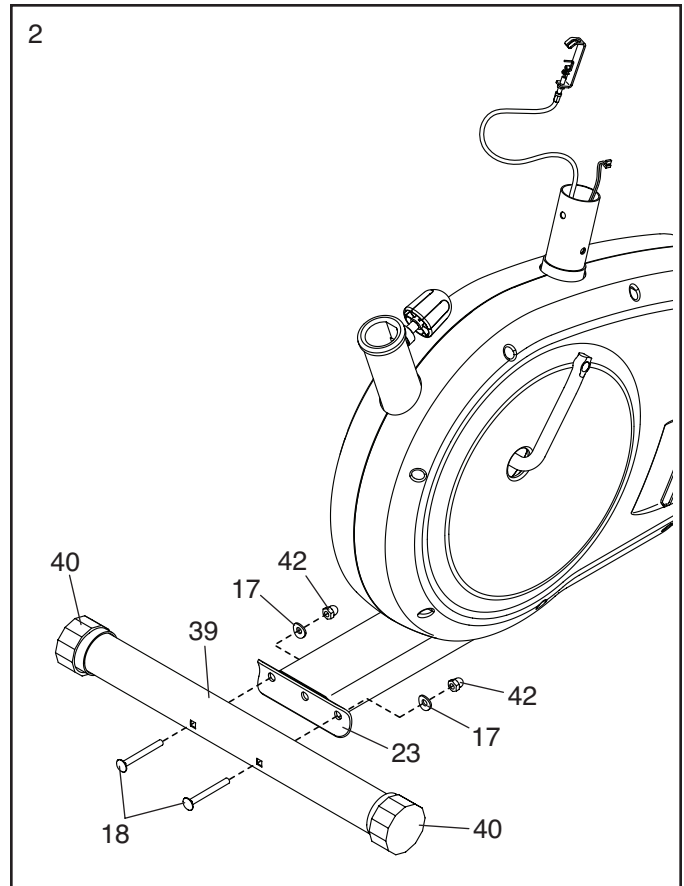

3. Attach the Front Stabilizer (41) to the Frame (23) with two M8 x 65mm Carriage Bolts (18), two M8 Curved Washers (17), and two M8 Acorn Nuts (42); **insert both Carriage Bolts, and then tighten the Acorn Nuts.**

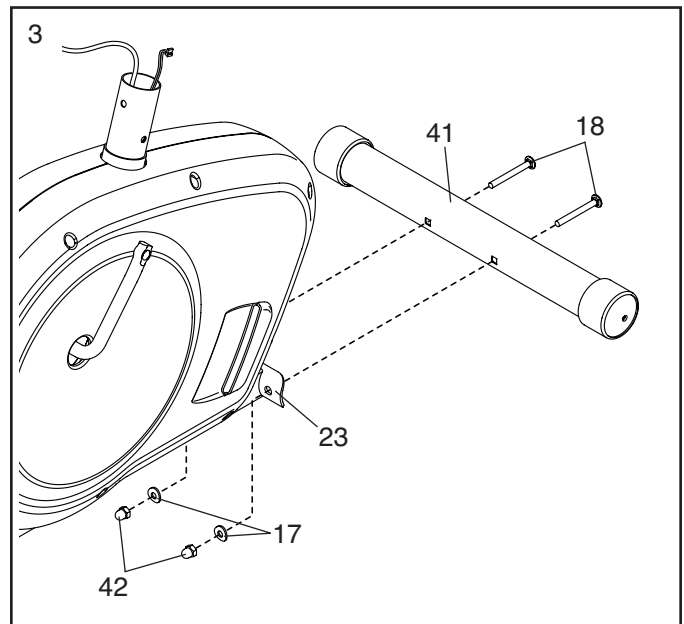

4. Attach the Seat (45) to the Seat Post (44) with three M8 Locknuts (9) and three M8 Large Washers (49); **start all the Locknuts, and then tighten them.**

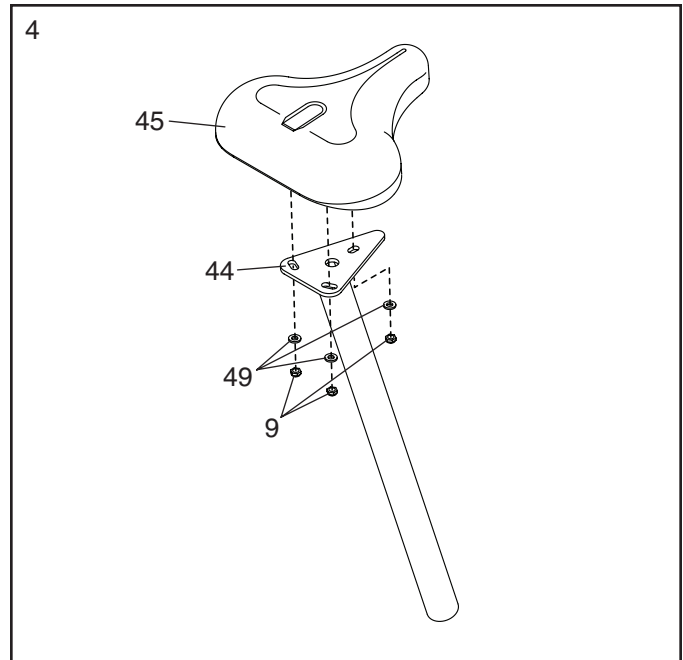

5. Loosen and remove the Seat Knob (24).

Next, insert the Seat Post (44) into the Seat Post Sleeve (26), and then insert the Seat Knob into the Frame (23) and into an adjustment hole in the Seat Post. **Move the Seat Post upward or downward slightly to make sure that the Seat Knob is engaged in one of the adjustment holes in the Seat Post.** Then, tighten the Seat Knob.

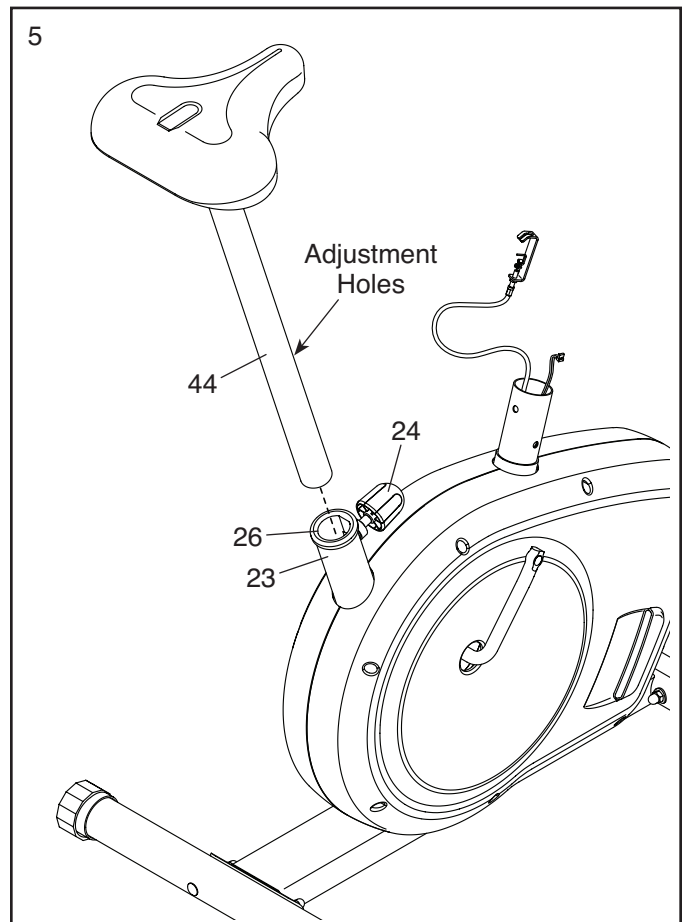

6. While a second person holds the Upright (35) near the Frame (23), connect the Upright Wire (36) to the Reed Switch Wire (7).

Next, push the Lower Resistance Cable (34) upward into the Upright (35), and then pull the end of the Lower Resistance Cable out of the indicated hole.

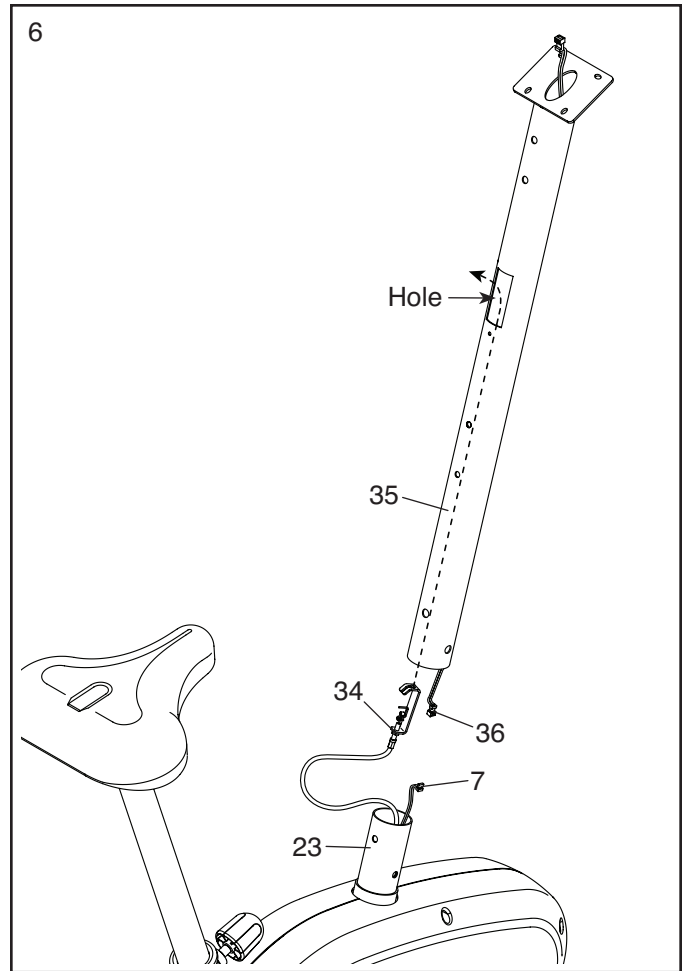

7. Insert the excess wire and cable into the Frame (23).

Tip: Avoid pinching the wire and the cable. Slide the Upright (35) onto the Frame (23).

Attach the Upright (35) with four M8 x 16mm Screws (22) and four M8 Curved Washers (17); **start all the Screws, and then tighten them.**

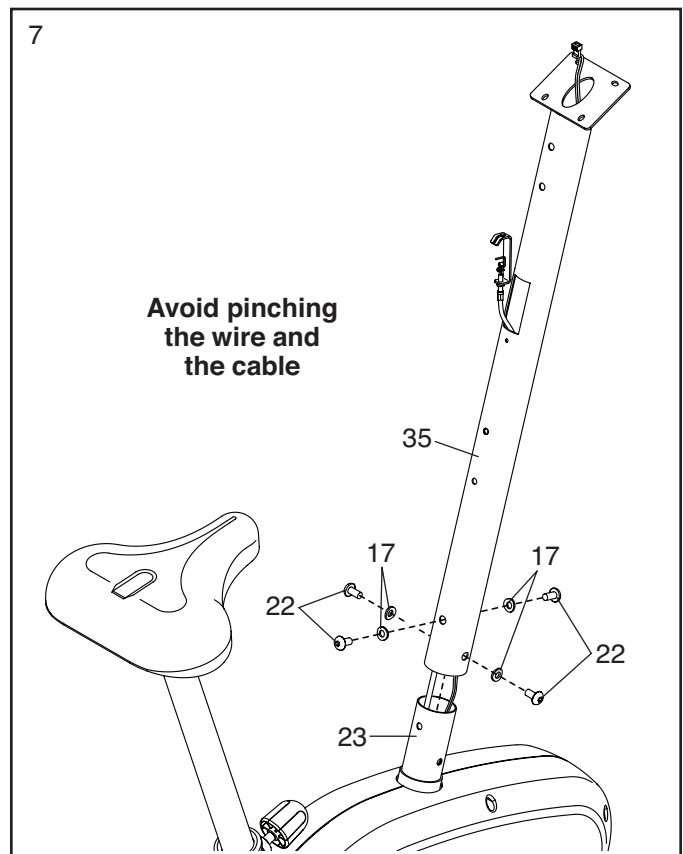

8. Connect the Resistance Cable (37) to the Lower Resistance Cable (34) in the following way:

See drawing A. Pull upward on the metal bracket (A) on the Lower Resistance Cable (34), and insert the tip of the Resistance Cable (37) into the wire clip inside the metal bracket.

See drawing B. Firmly pull the Resistance Cable (37) upward and slide it into the top of the metal bracket (A).

See drawing C. Using pliers, squeeze the prongs on the upper end of the metal bracket (A) together.

Then, attach the Resistance Control (37) to the Upright (35) with an M5 x 14mm Screw (38).

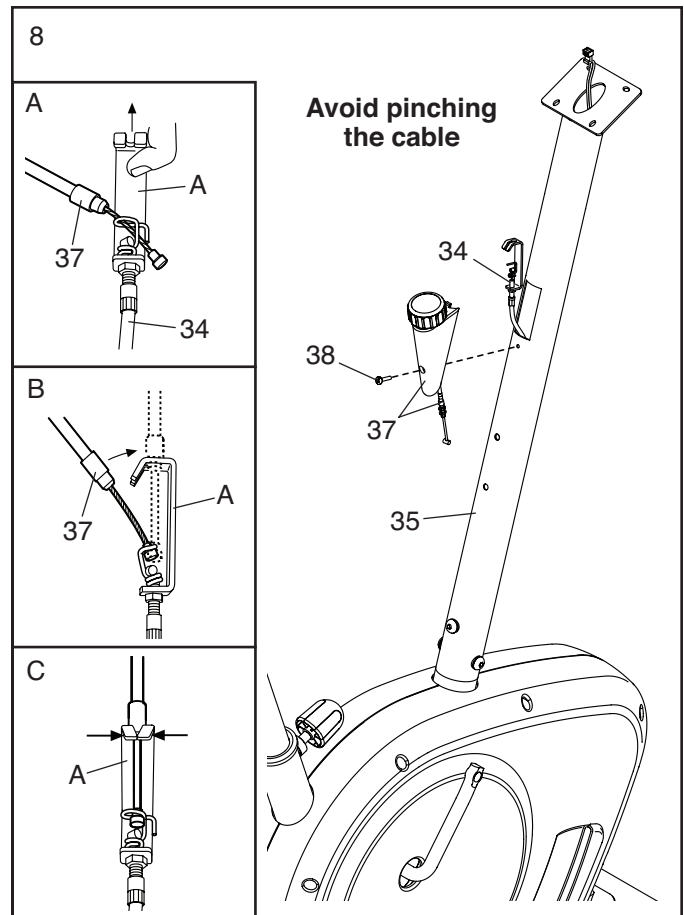

9. **Tip: Avoid damaging the Upright Wire (36).** Attach the Handlebar (46) to the Upright (35) with two M8 x 65mm Bolts (16), two M8 Curved Washers (17), and two M8 Acorn Nuts (42); **start both Bolts, and then tighten them.**

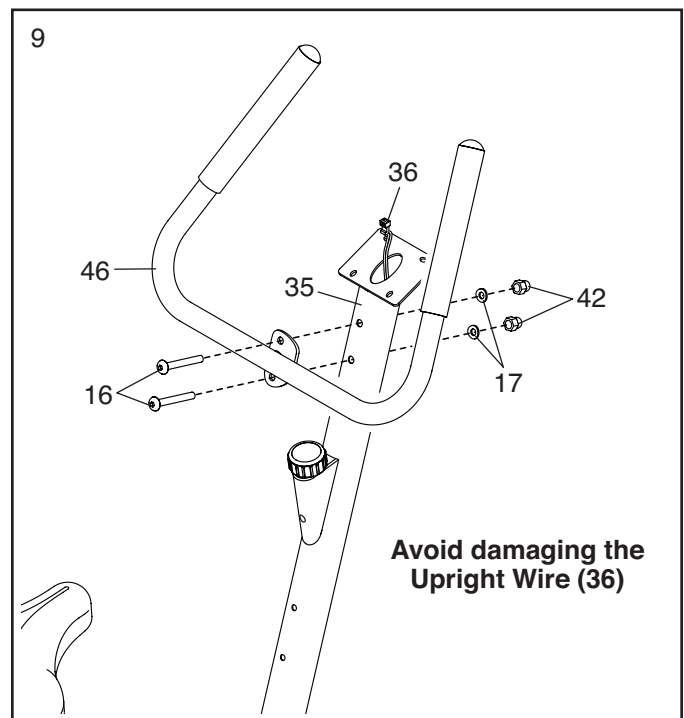

10. Attach the Water Bottle Holder (21) to the Upright (35) with two M5 x 20mm Screws (27); **start both Screws, and then tighten them.**

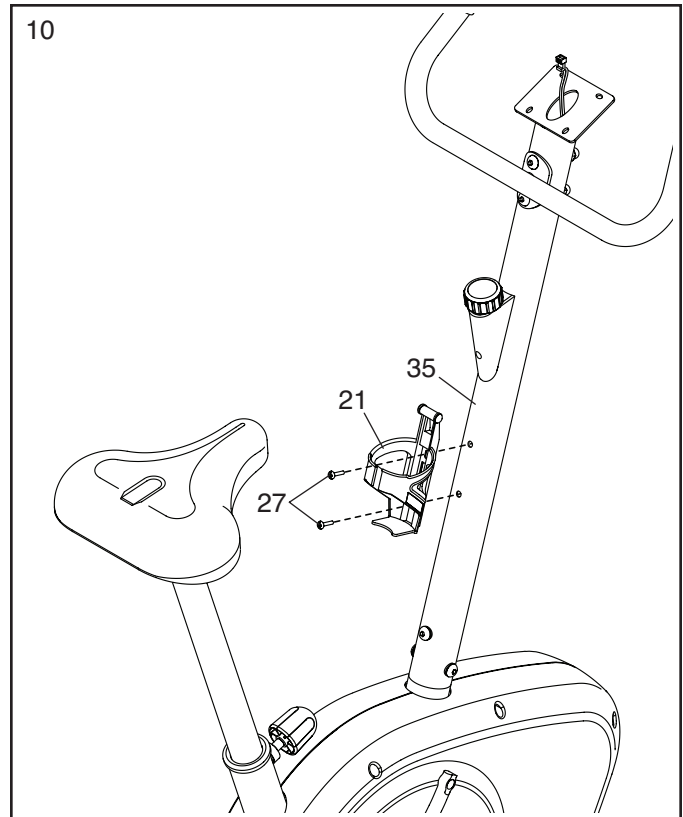

11. The Console (1) can use two AA batteries (not included); alkaline batteries are recommended. Do not use old and new batteries together or alkaline, standard, and rechargeable batteries together. **IMPORTANT: If the Console has been exposed to cold temperatures, allow it to warm to room temperature before you insert batteries. Otherwise, you may damage the console displays or other electronic components.**

Remove the battery cover from the back of the Console (1), and insert batteries into the battery compartment. **Make sure to orient the batteries as shown by the diagram inside the battery compartment.** Then, reattach the battery cover.

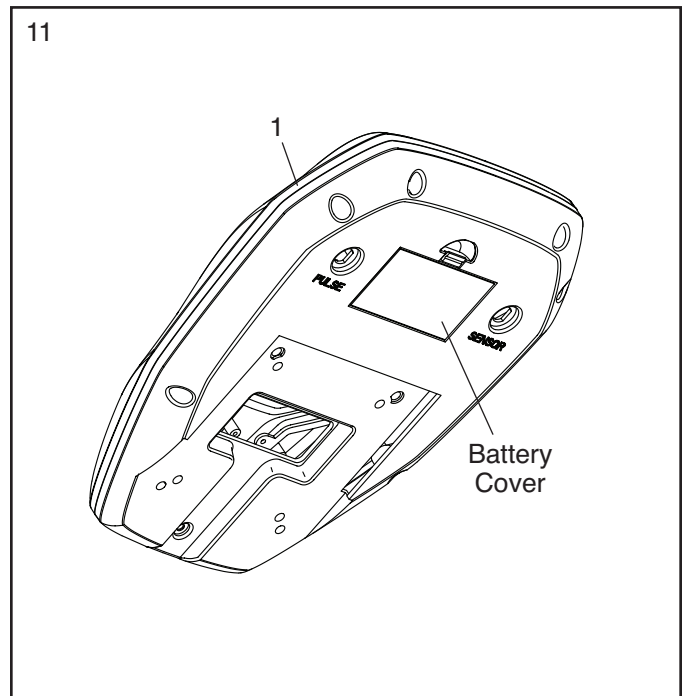

12. While a second person holds the Console (1) near the Upright (35), connect the wire on the Console to the Upright Wire (36).

Tip: Avoid pinching the wires. Attach the Console (1) to the Upright (35) with four M5 x 10mm Screws (2); **start all the Screws, and then tighten them.**

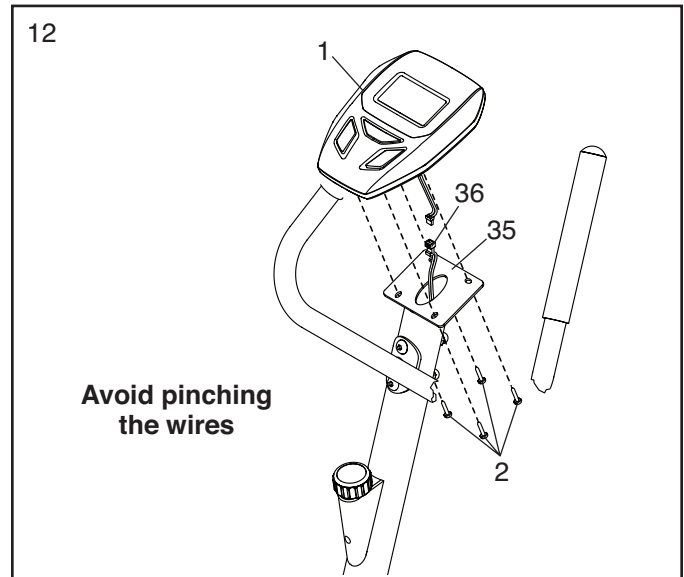

13. Identify the Right Pedal (33).

Using an adjustable wrench, **firmly tighten** the Right Pedal (33) **clockwise** into the right side of the Crank (3).

Firmly tighten the Left Pedal (not shown) counterclockwise into the left side of the Crank (not shown). IMPORTANT: You must turn the Left Pedal counterclockwise to attach it.

Attach the right pedal strap to the Right Pedal (33) as shown. **Attach the left pedal strap in the same way.**

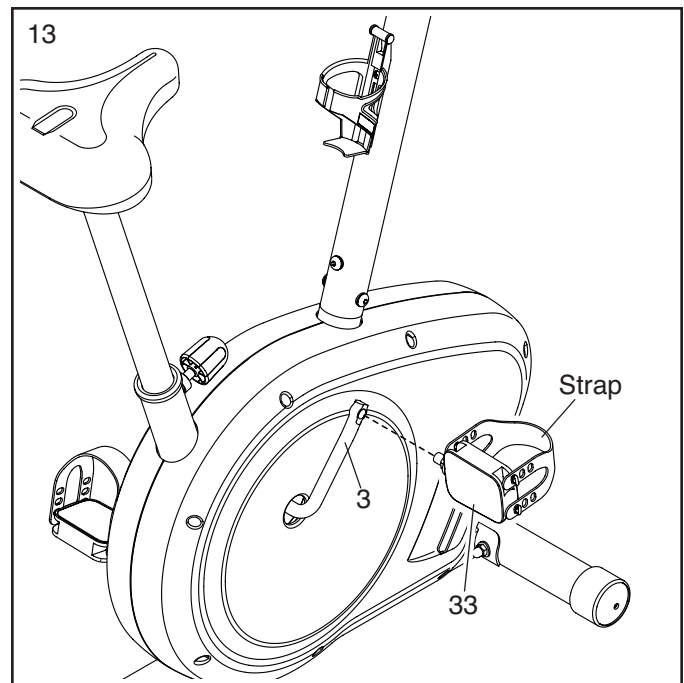

14. **After the exercise bike is assembled, inspect it to make sure that it is assembled correctly and that it functions properly. Make sure that all parts are properly tightened before you use the exercise bike.** Extra parts may be included. Place a mat under the exercise bike to protect the floor.

HOW TO USE THE EXERCISE BIKE

HOW TO ADJUST THE SEAT POST

For effective exercise, the seat should be at the proper height. As you pedal, there should be a slight bend in your knees when the pedals are in the lowest position.

To adjust the seat, loosen and remove the seat knob, slide the seat post upward or downward to the desired position, and then insert the seat knob into an adjustment hole in the seat post. **Move the seat post upward or downward slightly to make sure that the seat knob is engaged in one of the adjustment holes in the seat post.** Then, tighten the seat knob.

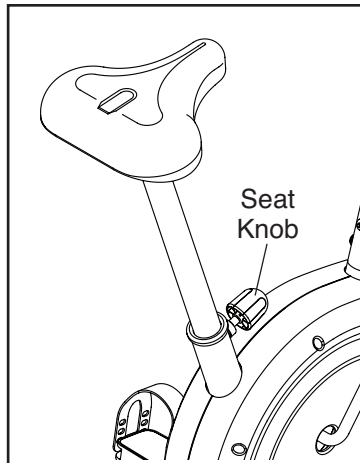

HOW TO ADJUST THE PEDALING RESISTANCE

To increase the resistance of the pedals, turn the resistance knob clockwise; **to decrease the resistance,** turn the knob counterclockwise.

IMPORTANT: Stop turning the knob when turning becomes difficult, or damage may result.

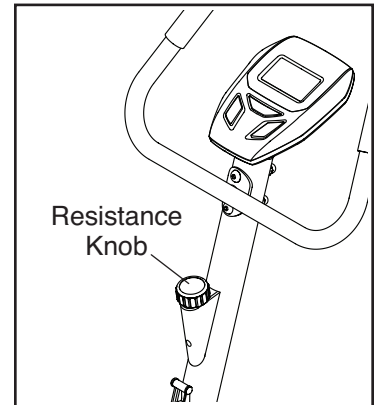

CONSOLE DIAGRAM

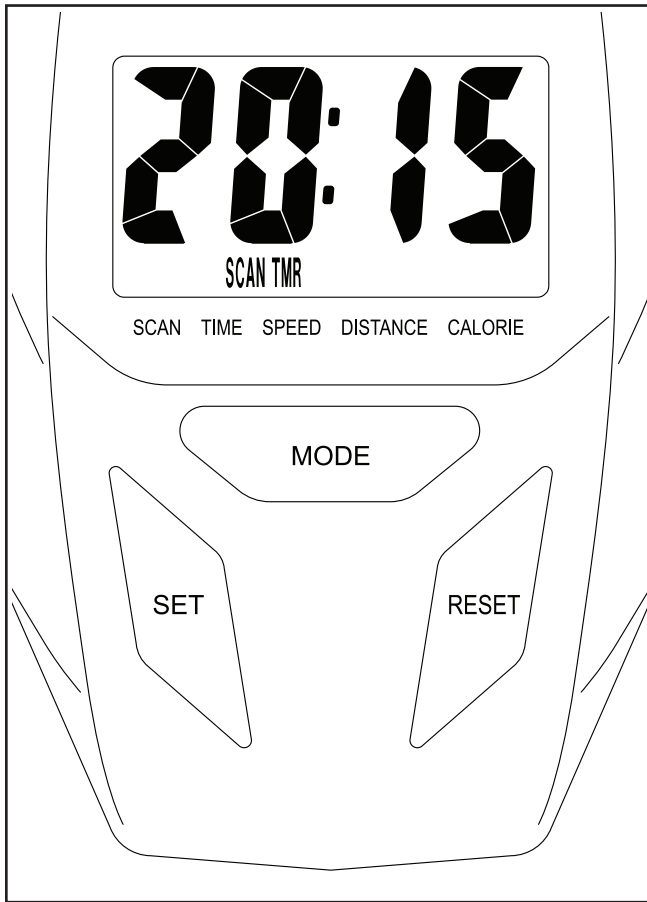

FEATURES OF THE CONSOLE

The easy-to-use console features five modes that provide instant exercise feedback during your workouts.

Scan (SCAN)—This mode displays the time, speed, distance, and calorie modes, for a few seconds each, in a repeating cycle.

Time (TMR)—This mode displays the elapsed time. Note: If you set a time goal (see step 2 on page 16), this display will show the time remaining in your workout.

Speed (SPD)—This mode displays your pedaling speed, in miles per hour.

Distance (DST)—This mode displays the distance you have pedaled during your workout, in miles. Note: If you set a distance goal (see step 2 on page 16), this display will show the distance remaining in your workout.

Calorie (CAL)—This mode displays the approximate number of calories you have burned during your workout. Note: If you set a calorie-burning goal (see step 2 on page 16), this display will show the number of calories yet to be burned in your workout.

HOW TO USE THE CONSOLE

Make sure that batteries (not included) are installed in the console (see assembly step 11 on page 12). If there is a sheet of plastic on the console, remove the plastic.

1. Turn on the console.

To turn on the console, press any button on the console or simply begin pedaling.

2. Set a workout goal if desired.

To set a time, distance, or calorie-burning goal for your workout, press the MODE button repeatedly until the word TMR, DST, or CAL, appears in the display. **Make sure that the word SCAN does not appear in the display.**

Next, press the SET button repeatedly to set a goal. To set a goal quickly, hold down the SET button. To reset the goal, press the RESET button.

3. Begin pedaling and follow your progress with the displays.

Scan mode—To select the scan mode, press the MODE button repeatedly until the word SCAN appears in the display.

Time, speed, distance, or calorie mode—To select one of these modes for continuous display, press the MODE button repeatedly until the name of the desired mode appears in the display. Make sure that the word SCAN does not appear in the display.

As you exercise, the console will provide instant feedback about your workout.

4. When you are finished exercising, the console will turn off automatically.

If the pedals do not move for a few seconds, the console will pause.

The console has an auto-off feature. If the pedals do not move and the console buttons are not pressed for a few minutes, the power will turn off automatically to save the batteries.

FCC INFORMATION

This equipment has been tested and found to comply with the limits for a Class B digital device, pursuant to part 15 of the FCC Rules. These limits are designed to provide reasonable protection against harmful interference in a residential installation. This equipment generates, uses, and can radiate radio frequency energy and, if not installed and used in accordance with the instructions, may cause harmful interference to radio communications. However, there is no guarantee that interference will not occur in a particular installation. If this equipment does cause harmful interference to radio or television reception, which can be determined by turning the equipment off and on, try to correct the interference by one or more of the following measures:

- Reorient or relocate the receiving antenna.
- Increase the separation between the equipment and the receiver.
- Connect the equipment into an outlet on a circuit different from that to which the receiver is connected.
- Consult the dealer or an experienced radio/TV technician for help.

FCC CAUTION: To assure continued compliance, use only shielded interface cables when connecting to computer or peripheral devices. Changes or modifications not expressly approved by the party responsible for compliance could void the user's authority to operate this equipment.

MAINTENANCE AND TROUBLESHOOTING

MAINTENANCE

Inspect and tighten all parts of the exercise bike regularly. Replace any worn parts immediately.

To clean the exercise bike, use a damp cloth and a small amount of mild detergent. **IMPORTANT: To avoid damage to the console, keep liquids away from the console and keep the console out of direct sunlight.**

CONSOLE TROUBLESHOOTING

If the console display becomes dim, replace the batteries (see assembly step 11 on page 12); most console problems are the result of low batteries.

HOW TO ADJUST THE REED SWITCH

If the console does not display correct feedback, the reed switch should be adjusted.

To adjust the reed switch, first turn the resistance knob to the lowest setting.

Next, using an adjustable wrench, turn the left pedal **clockwise** and remove it.

Then, **see the EXPLODED DRAWING on page 23.** Remove the M4 x 50mm Screws (31) and the 3/16" x 3/4" Screws (32) from the Left and Right Shields (29, 30); **note which size of Screw you remove from each hole.** Then, gently remove the Left Shield.

Locate the Reed Switch (7). Turn the Crank (3) until a Magnet (12) is aligned with the Reed Switch.

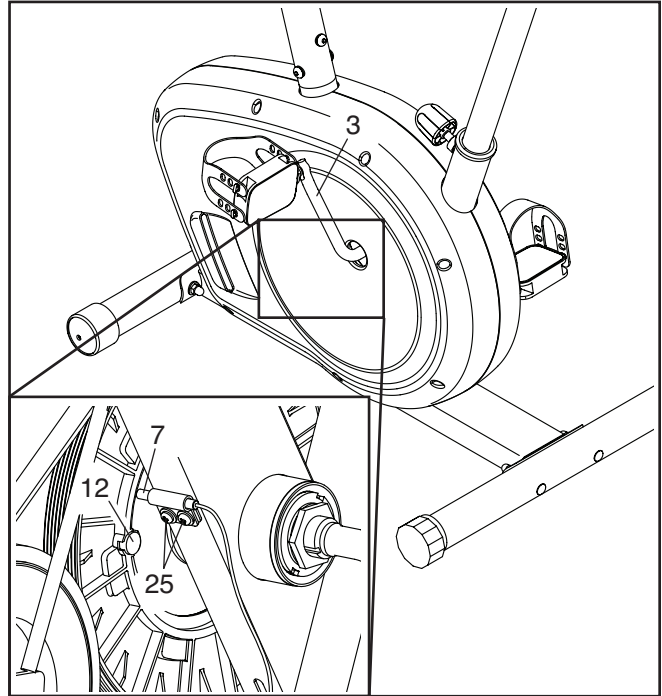

Next, loosen, but do not remove, the two M4 x 10mm Screws (25). Slide the Reed Switch (7) slightly closer to or away from the Magnet (12). Then, retighten the two Screws. Turn the Crank (3) for a moment.

Repeat these actions until the console displays correct feedback. When the reed switch is correctly adjusted, reattach the left shield and the left pedal.

HOW TO ADJUST THE DRIVE BELT

If you can feel the pedals slip while you are pedaling, even when the resistance is at the highest level, the drive belt may need to be adjusted.

To adjust the drive belt, you must first remove the right pedal and the right shield as described below.

Using an adjustable wrench, turn the right pedal **counterclockwise** and remove it.

Next, **see the EXPLODED DRAWING on page 23**. Remove the M4 x 50mm Screws (31) and the 3/16" x 3/4" Screws (32) from the Left and Right Shields (29, 30); **note which size of Screw you remove from each hole**. Then, gently remove the Right Shield.

Loosen the two M8 Locknuts (9) on the two M8 Idler Bolts (19). Then, tighten the M10 x 35mm Screw (20) until the Drive Belt (5) is tight. When the Drive Belt is tight, tighten the two Locknuts.

Then, reattach the right shield and the right pedal.

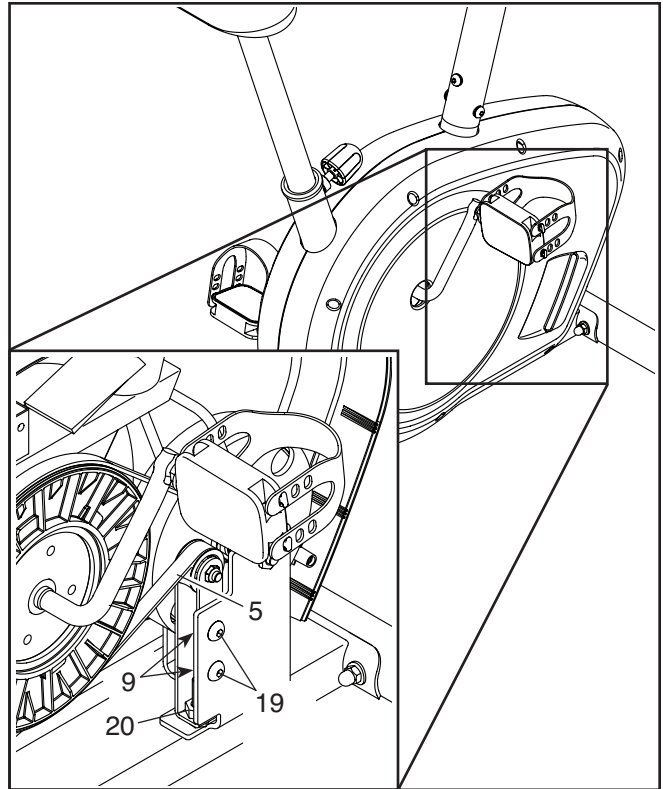

EXERCISE GUIDELINES

⚠️ WARNING: Before beginning this or any exercise program, consult your physician. This is especially important for persons over age 35 or persons with pre-existing health problems.

These guidelines will help you to plan your exercise program. For detailed exercise information, obtain a reputable book or consult your physician. Remember, proper nutrition and adequate rest are essential for successful results.

EXERCISE INTENSITY

Whether your goal is to burn fat or to strengthen your cardiovascular system, exercising at the proper intensity is the key to achieving results. You can use your heart rate as a guide to find the proper intensity level. The chart below shows recommended heart rates for fat burning and aerobic exercise.

165	155	145	140	130	125	115	♥️
145	138	130	125	118	110	103	♥️
125	120	115	110	105	95	90	♥️
<hr/>							
20	30	40	50	60	70	80	

To find the proper intensity level, find your age at the bottom of the chart (ages are rounded off to the nearest ten years). The three numbers listed above your age define your “training zone.” The lowest number is the heart rate for fat burning, the middle number is the heart rate for maximum fat burning, and the highest number is the heart rate for aerobic exercise.

Burning Fat—To burn fat effectively, you must exercise at a low intensity level for a sustained period of time. During the first few minutes of exercise, your body uses carbohydrate calories for energy. Only after the first few minutes of exercise does your body begin to use stored fat calories for energy. If your goal is to burn fat, adjust the intensity of your exercise until your heart rate is near the lowest number in your training zone. For maximum fat burning, exercise with your heart rate near the middle number in your training zone.

Aerobic Exercise—If your goal is to strengthen your cardiovascular system, you must perform aerobic exercise, which is activity that requires large amounts of oxygen for prolonged periods of time. For aerobic exercise, adjust the intensity of your exercise until your heart rate is near the highest number in your training zone.

HOW TO MEASURE YOUR HEART RATE

To measure your heart rate, exercise for at least four minutes. Then, stop exercising and place two fingers on your wrist as shown. Take a six-second heartbeat count, and multiply the result by 10 to find your heart rate. For example, if your six-second heartbeat count is 14, your heart rate is 140 beats per minute.

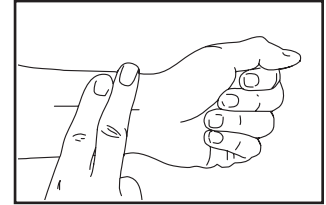

WORKOUT GUIDELINES

Warming Up—Start with 5 to 10 minutes of stretching and light exercise. A warm-up increases your body temperature, heart rate, and circulation in preparation for exercise.

Training Zone Exercise—Exercise for 20 to 30 minutes with your heart rate in your training zone. (During the first few weeks of your exercise program, do not keep your heart rate in your training zone for longer than 20 minutes.) Breathe regularly and deeply as you exercise; never hold your breath.

Cooling Down—Finish with 5 to 10 minutes of stretching. Stretching increases the flexibility of your muscles and helps to prevent post-exercise problems.

EXERCISE FREQUENCY

To maintain or improve your condition, complete three workouts each week, with at least one day of rest between workouts. After a few months of regular exercise, you may complete up to five workouts each week, if desired. Remember, the key to success is to make exercise a regular and enjoyable part of your everyday life.

SUGGESTED STRETCHES

The correct form for several basic stretches is shown at the right. Move slowly as you stretch; never bounce.

1. Toe Touch Stretch

Stand with your knees bent slightly and slowly bend forward from your hips. Allow your back and shoulders to relax as you reach down toward your toes as far as possible. Hold for 15 counts, then relax. Repeat 3 times. Stretches: Hamstrings, back of knees and back.

2. Hamstring Stretch

Sit with one leg extended. Bring the sole of the opposite foot toward you and rest it against the inner thigh of your extended leg. Reach toward your toes as far as possible. Hold for 15 counts, then relax. Repeat 3 times for each leg. Stretches: Hamstrings, lower back and groin.

3. Calf/Achilles Stretch

With one leg in front of the other, reach forward and place your hands against a wall. Keep your back leg straight and your back foot flat on the floor. Bend your front leg, lean forward and move your hips toward the wall. Hold for 15 counts, then relax. Repeat 3 times for each leg. To cause further stretching of the achilles tendons, bend your back leg as well. Stretches: Calves, achilles tendons and ankles.

4. Quadriceps Stretch

With one hand against a wall for balance, reach back and grasp one foot with your other hand. Bring your heel as close to your buttocks as possible. Hold for 15 counts, then relax. Repeat 3 times for each leg. Stretches: Quadriceps and hip muscles.

5. Inner Thigh Stretch

Sit with the soles of your feet together and your knees outward. Pull your feet toward your groin area as far as possible. Hold for 15 counts, then relax. Repeat 3 times. Stretches: Quadriceps and hip muscles.

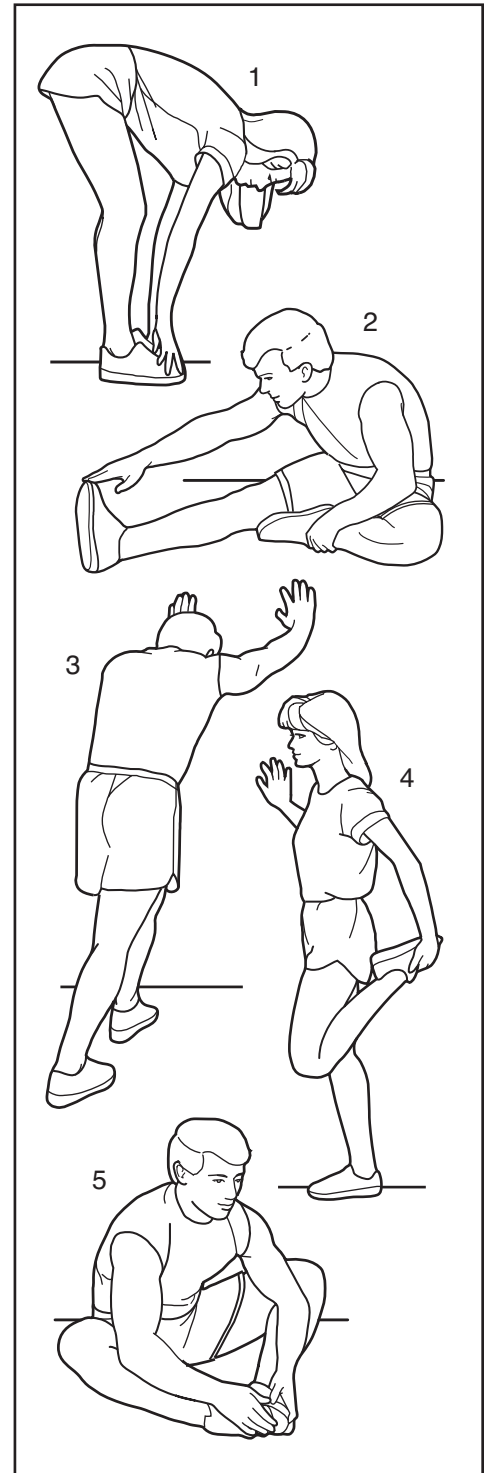

PART LIST

Model No. WLEX81214.0 R1115A

Key No.	Qty.	Description	Key No.	Qty.	Description
1	1	Console	27	2	M5 x 20mm Screw
2	4	M5 x 10mm Screw	28	1	Clamp
3	1	Crank/Pulley	29	1	Left Shield
4	2	M4 Washer	30	1	Right Shield
5	1	Drive Belt	31	5	M4 x 50mm Screw
6	1	Eddy Mechanism	32	6	3/16" x 3/4" Screw
7	1	Reed Switch/Wire	33	1	Right Pedal/Strap
8	1	Left Pedal/Strap	34	1	Lower Resistance Cable
9	5	M8 Locknut	35	1	Upright
10	1	Crank Hardware	36	1	Upright Wire
11	2	Grip	37	1	Resistance Control/Cable
12	2	Magnet	38	1	M5 x 14mm Screw
13	2	M10 Jam Nut	39	1	Rear Stabilizer
14	1	Idler	40	2	Leveling Cap
15	2	M10 Washer	41	1	Front Stabilizer
16	2	M8 x 65mm Bolt	42	6	M8 Acorn Nut
17	10	M8 Curved Washer	43	2	Front Stabilizer Cap/Wheel
18	4	M8 x 65mm Carriage Bolt	44	1	Seat Post
19	2	M8 Idler Bolt	45	1	Seat
20	1	M10 x 35mm Screw	46	1	Handlebar
21	1	Water Bottle Holder	47	2	Handlebar Cap
22	4	M8 x 16mm Screw	48	2	M8 Washer
23	1	Frame	49	3	M8 Large Washer
24	1	Seat Knob	*	–	Assembly Tool
25	2	M4 x 10mm Screw	*	–	User's Manual
26	1	Seat Post Sleeve			

Note: Specifications are subject to change without notice. For information about ordering replacement parts, see the back cover of this manual. *These parts are not illustrated.

EXPLODED DRAWING

Model No. WLEX81214.0 R1115A

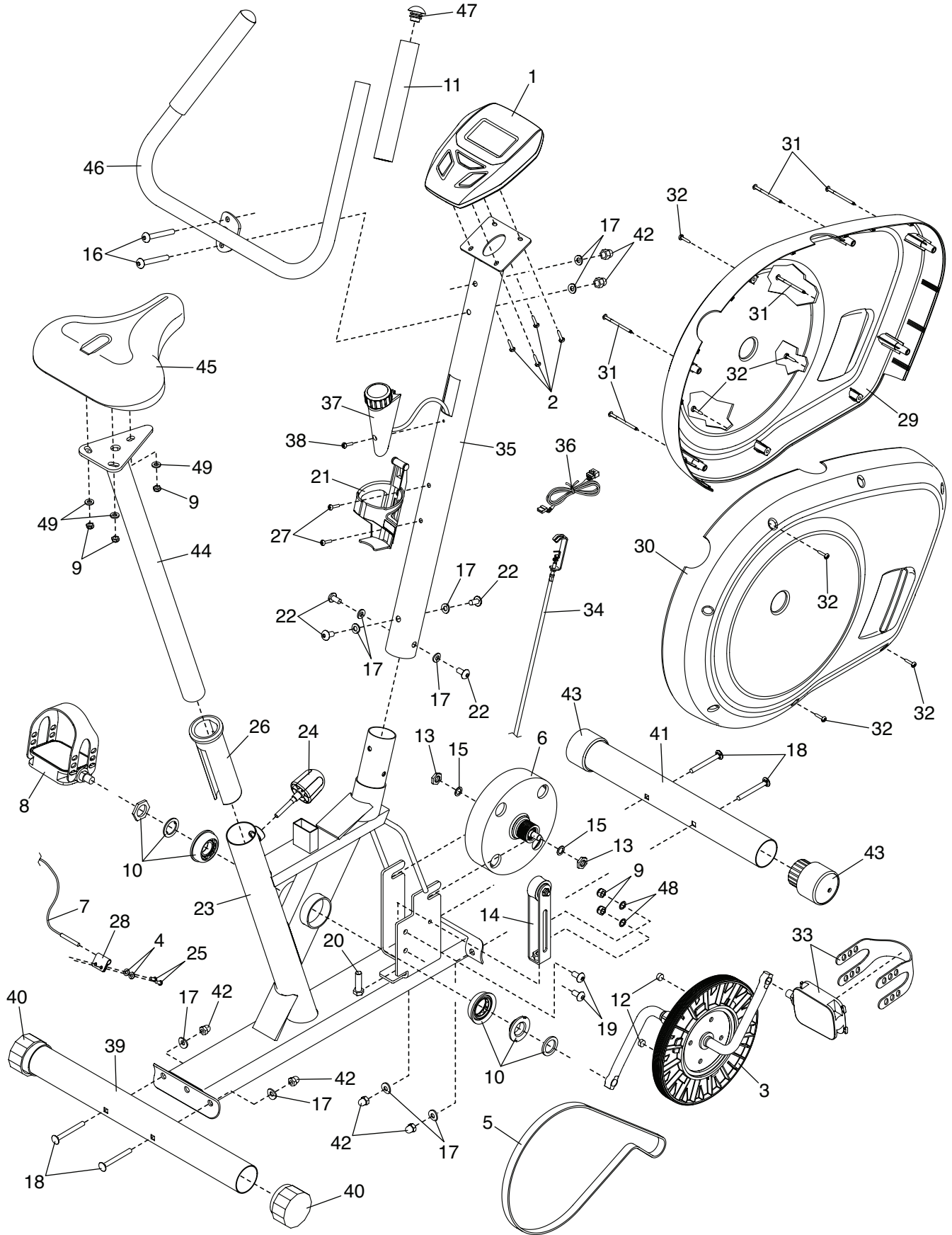

ORDERING REPLACEMENT PARTS

To order replacement parts, please see the front cover of this manual. To help us assist you, be prepared to provide the following information when contacting us:

- the model number and serial number of the product (see the front cover of this manual)
- the name of the product (see the front cover of this manual)
- the key number and description of the replacement part(s) (see the PART LIST and the EXPLODED DRAWING near the end of this manual)

LIMITED WARRANTY

IMPORTANT: To protect your fitness equipment with an extended service plan, see page 4.

ICON Health & Fitness, Inc. (ICON) warrants this product to be free from defects in workmanship and material, under normal use and service conditions. Parts and labor are warranted for ninety (90) days from the date of purchase.

This warranty extends only to the original purchaser (customer). ICON's obligation under this warranty is limited to repairing or replacing, at ICON's option, the product through one of its authorized service centers. All repairs for which warranty claims are made must be preauthorized by ICON. If the product is shipped to a service center, freight charges to and from the service center will be the customer's responsibility. If replacement parts are shipped while the product is under warranty, the customer will be responsible for a minimal handling charge. For in-home service, the customer will be responsible for a minimal trip charge. This warranty does not extend to freight damage to the product. This warranty will automatically be voided if the product is used as a store display model, if the product is purchased or transported outside the USA, if all instructions in this manual are not followed, if the product is abused or improperly or abnormally used, or if the product is used for commercial or rental purposes. No other warranty beyond that specifically set forth above is authorized by ICON.

ICON is not responsible or liable for indirect, special, or consequential damages arising out of or in connection with the use or performance of the product; damages with respect to any economic loss, loss of property, loss of revenues or profits, loss of enjoyment or use, or costs of removal or installation; or other consequential damages of any kind. Some states do not allow the exclusion or limitation of incidental or consequential damages. Accordingly, the above limitation may not apply to the customer.

The warranty extended hereunder is in lieu of any and all other warranties, and any implied warranties of merchantability or fitness for a particular purpose are limited in their scope and duration to the terms set forth herein. Some states do not allow limitations on how long an implied warranty lasts. Accordingly, the above limitation may not apply to the customer.

This warranty provides specific legal rights; the customer may have other rights that vary from state to state.

ICON Health & Fitness, Inc., 1500 S. 1000 W., Logan, UT 84321-9813