



TimeCutter® HD Riding Mower

Model No. 74864—Serial No. 400000000 and Up

Model No. 74865—Serial No. 400000000 and Up

Model No. 74866—Serial No. 400000000 and Up

Model No. 74867—Serial No. 400000000 and Up

Model No. 75201—Serial No. 400000000 and Up

Model No. 75202—Serial No. 400000000 and Up

Model No. 75203—Serial No. 400000000 and Up

Model No. 75210—Serial No. 400000000 and Up

Model No. 75211—Serial No. 400000000 and Up

Model No. 75212—Serial No. 400000000 and Up

Model No. 75213—Serial No. 400000000 and Up

Setup Instructions

Setup

Loose Parts

Use the chart below to verify that all parts have been shipped.

Procedure	Description	Qty.	Use
1	No parts required	–	Connect the battery.
2	Rear hitch Bolt (5/16 x 1 inch) Locknut (5/16 inch)	1 2 2	Install the rear hitch.
3	No parts required	–	Set up the motion-control levers (CE machines only).
4	No parts required	–	Check the mower adjustment.
5	Ignition key Hose coupling (non-CE machines only) Operator's Manual Engine owner's manual (non-Toro engines only) Operator training material	1 1 1 1 1	Complete the setup.

Note: Determine the left and right sides of the machine from the normal operating position.



1

Connecting the Battery

No Parts Required

Procedure

⚠ WARNING

CALIFORNIA Proposition 65 Warning

Battery posts, terminals, and related accessories contain lead and lead compounds, chemicals known to the State of California to cause cancer and reproductive harm. Wash hands after handling.

1. Loosen the 2 fasteners on the battery cover counterclockwise 1/4 turn and remove the battery cover (Figure 1).

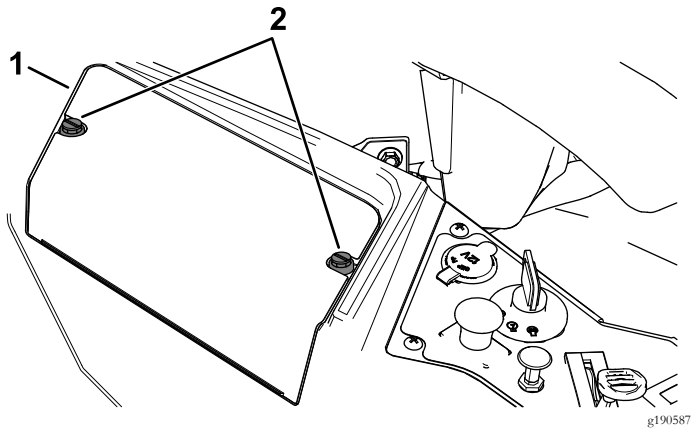

Figure 1

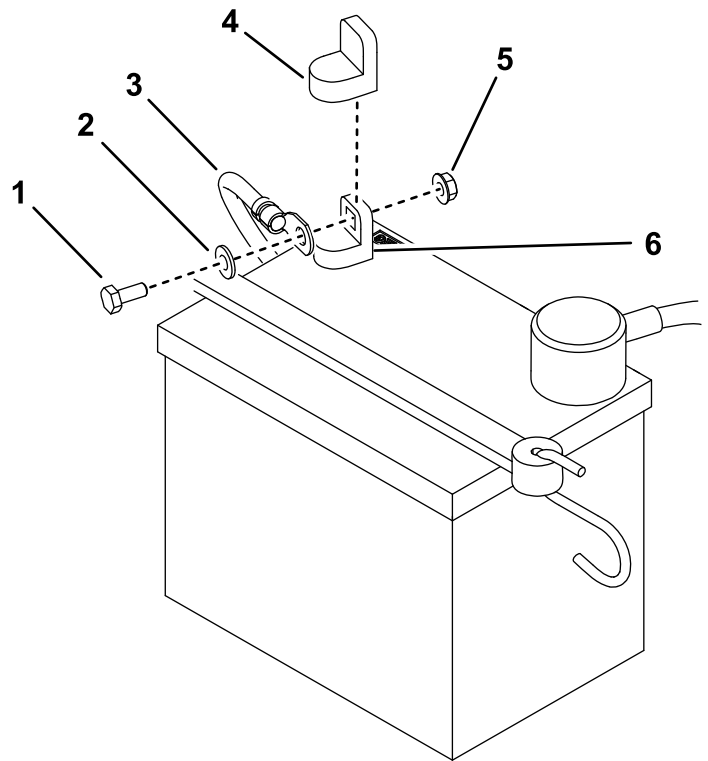

Figure 2

- | | |
|---------------------------|------------------------------|
| 1. Hex bolt | 4. Negative battery post cap |
| 2. Washer | 5. Nut |
| 3. Negative battery cable | 6. Negative battery post |

2. Remove the plastic cap from the negative battery post.
3. Remove the fasteners on the negative battery cable, and use them to secure the negative battery cable to the negative battery post (Figure 2).

2

Installing the Rear Hitch

Parts needed for this procedure:

1	Rear hitch
2	Bolt (5/16 x 1 inch)
2	Locknut (5/16 inch)

Procedure

Install the bracket to the frame as shown in [Figure 3](#) and [Figure 4](#).

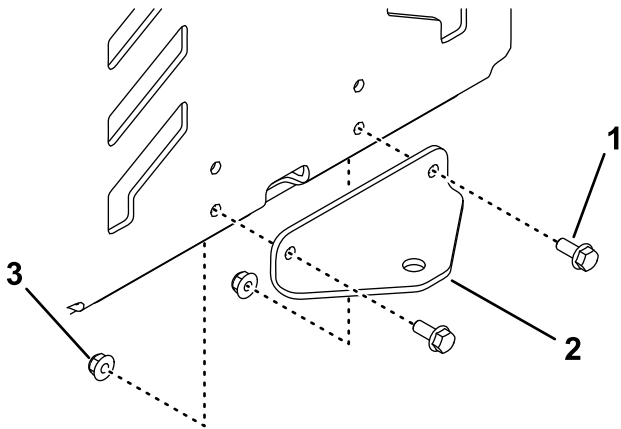

Figure 3
Before assembly

g191160

- 1. Bolt
- 2. Bracket
- 3. Locknut

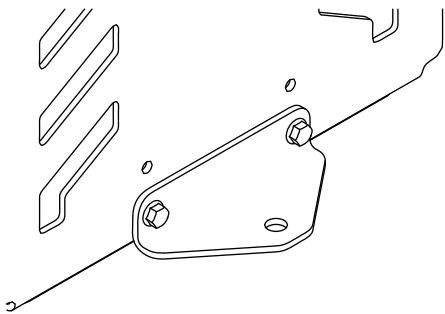

Figure 4
After assembly

g191159

3

Setting Up the Motion-Control Levers

CE Machines Only

No Parts Required

Procedure

1. Locate the motion-control levers attached, but folded down on the machine.
2. Remove the upper bolt (3/8 x 1 inch) and washer; loosen the lower bolt (3/8 x 1 inch).
3. Raise the motion control levers to the upright position.
4. Align the holes in the motion-control lever with the holes in the control-arm shaft, and install the bolt and washer removed previously. Repeat this for both controls levers.

Note: Hand tighten all fasteners.

5. Move the motion-control levers to the park position, raise the seat, and move the control levers back to the center position (neutral).
6. Verify that the motion-control levers are properly aligned.

Note: Adjust as necessary. Tighten all fasteners.

4

Checking the Mower Adjustment

No Parts Required

Procedure

Adjust the side-to-side level and the front-to-rear blade slope. Use the relevant procedures in the *Operator's Manual* to verify that the deck is level, and make any adjustments as necessary. Refer to the *Operator's Manual* for more information.

5

Completing the Setup

Parts needed for this procedure:

1	Ignition key
1	Hose coupling (non-CE machines only)
1	<i>Operator's Manual</i>
1	Engine owner's manual (non-Toro engines only)
1	Operator training material

Checking the Tire Pressure

Check the front and rear tires for proper inflation; refer to Checking the Tire Pressure in the *Operator's Manual* for the recommended inflation pressure.

Checking the Side-Discharge Chute

Remove the packing restraint holding the side-discharge chute up and lower the chute into place.

Checking the Engine-Oil Level

Before you start the engine and use the machine, check the oil level in the engine crankcase; refer to Checking the Oil Level in the *Operator's Manual*.

Checking the Air Cleaner

Ensure that the air cleaner is properly installed in the engine air-cleaner box.

Organizing the Material

Keep all the following items with the machine:

- Ignition key
- Hose coupling (non-CE machines only)
- *Operator's Manual*
- Engine owners's manual (non-Toro engines only)
- View the operator training material before operating the machine.