

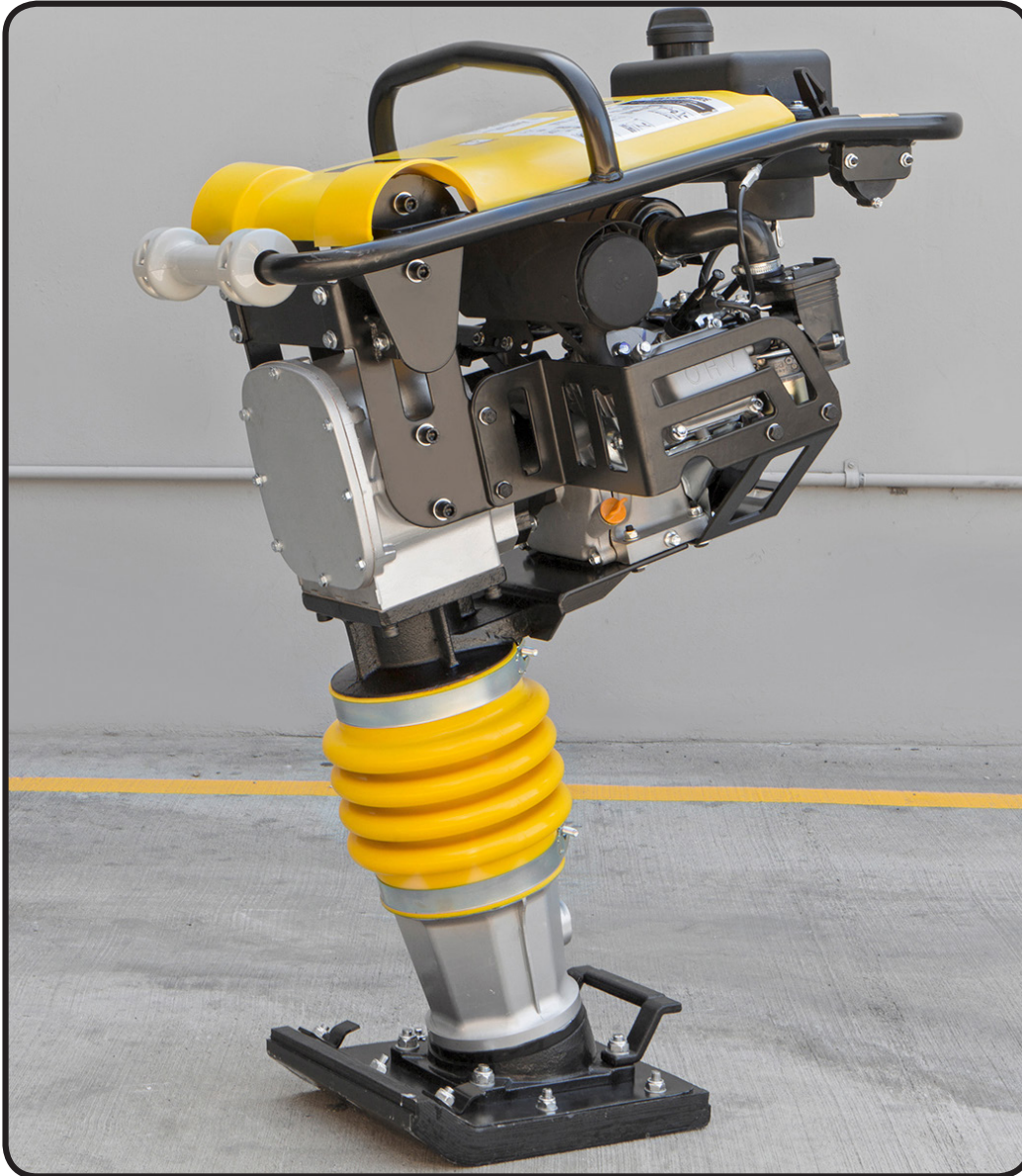

6.5HP JUMPING IMPACT TAMPING RAMMER

ITEM: 61009



OWNER'S MANUAL AND SAFETY INSTRUCTIONS

SAVE THIS MANUAL: KEEP THIS MANUAL FOR SAFETY WARNINGS, PRECAUTIONS, ASSEMBLY, OPERATING, INSPECTION, MAINTENANCE AND CLEANING PROCEDURES. WRITE THE PRODUCT'S SERIAL NUMBER ON THE BACK OF THE MANUAL NEAR THE ASSEMBLY DIAGRAM (OR MONTH AND YEAR OF PURCHASE IF PRODUCT HAS NO NUMBER).

FOR QUESTIONS PLEASE CALL OUR CUSTOMER SUPPORT: (909) 628 4900 MON-FRI 9AM TO 3PM PST



GENERAL SAFETY WARNINGS

Read all safety warnings and instructions. Failure to follow the warnings and instructions may result in electric shock, fire and/or serious injury. Save all warnings and instructions for future reference.

SAFETY

The warnings, precautions, and instructions discussed in this instruction manual cannot cover all possible conditions and situations that may occur. It must be understood by the operator that common sense and caution are factors which cannot be built into this product, but must be supplied by the operator. Read carefully and understand all ASSEMBLY AND OPERATION INSTRUCTIONS before operating. Failure to follow the safety rules and other basic safety precautions may result in serious personal injury.

- **Read and understand all instructions.** Failure to follow all instructions may result in serious injury or property damage.
- **DO NOT** allow persons to operate or assemble the product until they have read this manual and have developed a thorough understanding of how it works.
- **DO NOT modify this product in any way.** Unauthorized modification may impair the function and/or safety and could affect the life of the product. There are specific applications for which the product was designed.
- **Use the right tool for the job. DO NOT** attempt to force small equipment to do the work of larger industrial equipment. There are certain applications for which this equipment was designed. This product will be safer and do a better job at the capacity for which it was intended. **DO NOT** use this equipment for a purpose for which it was not intended.
- Industrial or commercial applications must follow OSHA requirements.
- **Inspect the work area before each use.** Keep work area clean, dry, free of clutter, and well-lit. Cluttered, wet, or dark work areas can result in injury. Using the product in confined work areas may put you dangerously close to cutting tools and rotating parts.
- **DO NOT use the product where there is a risk of causing a fire or an explosion;** e.g., in the presence of flammable liquids, gases, or dust. The product can create sparks, which may ignite the flammable liquids, gases, or dust.
- **DO NOT allow the product to come into contact with an electrical source.** The tool is not insulated and contact will cause electrical shock.
- **Keep children and bystanders away from the work area while operating the tool. DO NOT** allow children to handle the product.
- **Be aware of all power lines, electrical circuits, water pipes, and other mechanical hazards in your work area.** Some of these hazards may be hidden from your view and may cause personal injury and/or property damage if contacted.

IMPORTANT SAFETY INFORMATION

- Stay alert, watch what you are doing, and use common sense when operating the tool. **DO NOT** use the tool while you are tired or under the influence of drugs, alcohol, or medication.
- **Dress properly. DO NOT** wear loose clothing, dangling objects, or jewellery. Keep your hair, clothing and gloves away from moving parts. Loose clothes, jewellery, or long hair can be caught in moving parts. Air vents on the tool often cover moving parts and should be avoided.
- **Wear the proper personal protective equipment when necessary.** Use ANSI Z87.1 compliant safety goggles (not safety glasses) with side shields, or when needed, a face shield. Use a dust mask in dusty work conditions. Also use non-skid safety shoes, hard-hat, gloves, dust collection systems, and hearing protection when appropriate. This applies to all persons in the work area.
- **DO NOT overreach.** Keep proper footing and balance at all times.
- Remove keys or wrenches before connecting the tool to an air supply, power supply, or turning on the tool. A wrench or key that is left attached to a rotating part of the tool may cause personal injury.
- **Secure the work with clamps or a vise instead of your hand when practical.** This safety precaution allows for proper tool operation using both hands.
- **DO NOT force the tamping rammer.** Products are safer and do a better job when used in the manner for which they are designed. Plan your work, and use the correct product for the job.
- **Check for damaged parts before each use.** Carefully check that the product will operate properly and perform its intended function. Replace damaged or worn parts immediately. Never operate the product with a damaged part.
- **DO NOT use a product with a malfunctioning switch.** Any power tool that cannot be controlled with the power switch is dangerous and must be repaired by an authorized service representative before using.
- **Disconnect the power/air supply from the product and place the switch in the locked or off position before making any adjustments,** changing accessories, or storing the tool. Such preventive safety
- **Store the tamping rammer when it is not in use.** Store it in a dry, secure place out of the reach of children. Inspect the tool for good working condition prior to storage and before re-use.
- **Use only accessories that are recommended by the manufacturer for use with your product.** Accessories that may be suitable for one product may create a risk of injury when used with another tool. Never use an accessory that has a lower operating speed or operating pressure than the tool itself.
- **Keep guards in place and in working order.** Never operate the product without the guards in place.
- **DO NOT leave the tool running unattended.**
- Always wear the proper protective equipment including ANSI Z87.1 compliant eye protection, NIOSH compliant breathing protection, anti-vibration work gloves, steel toed work boots, and a helmet.

IMPORTANT SAFETY INFORMATION

- Using a tamping rammer indoors can kill you in minutes. Engine exhaust contains carbon Monoxide. This is a poison you cannot see or smell. Never use inside a home or garage, even if doors and windows are open. Only use outside and far away from windows, doors, and vents.
- Crushing hazard. Keep feet clear from under the tamping rammer.
- Burn hazard. **DO NOT** touch the hot exhaust manifold, muffler, or cylinder. Allow these parts to cool before servicing engine or rammer.
- Fire and explosion hazard. Fuel is flammable and explosive. Shut engine off and allow the engine to cool before adding fuel. Clean up fuel spills immediately. **DO NOT** smoke and keep sources of sparks and flames away.
- Keep bystanders at least 20 feet away from work area. Persons in the work area must wear the same proper protective equipment that the operator is instructed to wear.
- Before each use, check for fuel leaks and be sure all nuts and bolts are securely fastened.
- After use, secure the rammer to prevent it from tipping over. Injury to person(s) can result from the rammer falling on someone.
- **NEVER** operate this equipment when not feeling well due to fatigue, illness, or taking medicine.
- **NEVER** operate this equipment while under the influence of alcohol or drugs.
- Securely fasten the compactor for transportation. Insecure fastening of the compactor may cause damage or injury during transportation.
- **DO NOT** transport the compactor by motor vehicle with fuel in its fuel tank.
- **DO NOT** modify this equipment for any reason.
- Use only accessories and attachments recommended by the manufacturer.
- Please read this manual and gasoline engine directions carefully and learn the key points of operating rules before operating the rammer.
- Please check the air filter every time before operating the rammer in order to prevent accelerating the attrition of the engine.
- Please ensure the lubricating oil is adequate every time before operating the rammer in order to prevent the rammer from being damaged.
- Please ensure the bolts and all parts of the rammer are fastened every time before operating the rammer.
- **DO NOT** not operate the rammer on cement or hard ground. Only operate on compact, level ground.
- Close the rammer immediately if you hear an abnormal sound from the rammer when you operate it.
- Hold the handrail just enough to prevent the rammer from tilting and control the advancing speed and direction. You can change the advancing direction by rotating the handrail.
- Hold down the handrail softly on the slope or on loose ground so as to accelerate the advancing speed.
- When using this rammer on earth surfaces, it should be rammed layer by layer with less than 250mm. Each layer should be rammed repeatedly for three times or more where it is needed.

FEATURES AND SPECIFICATIONS

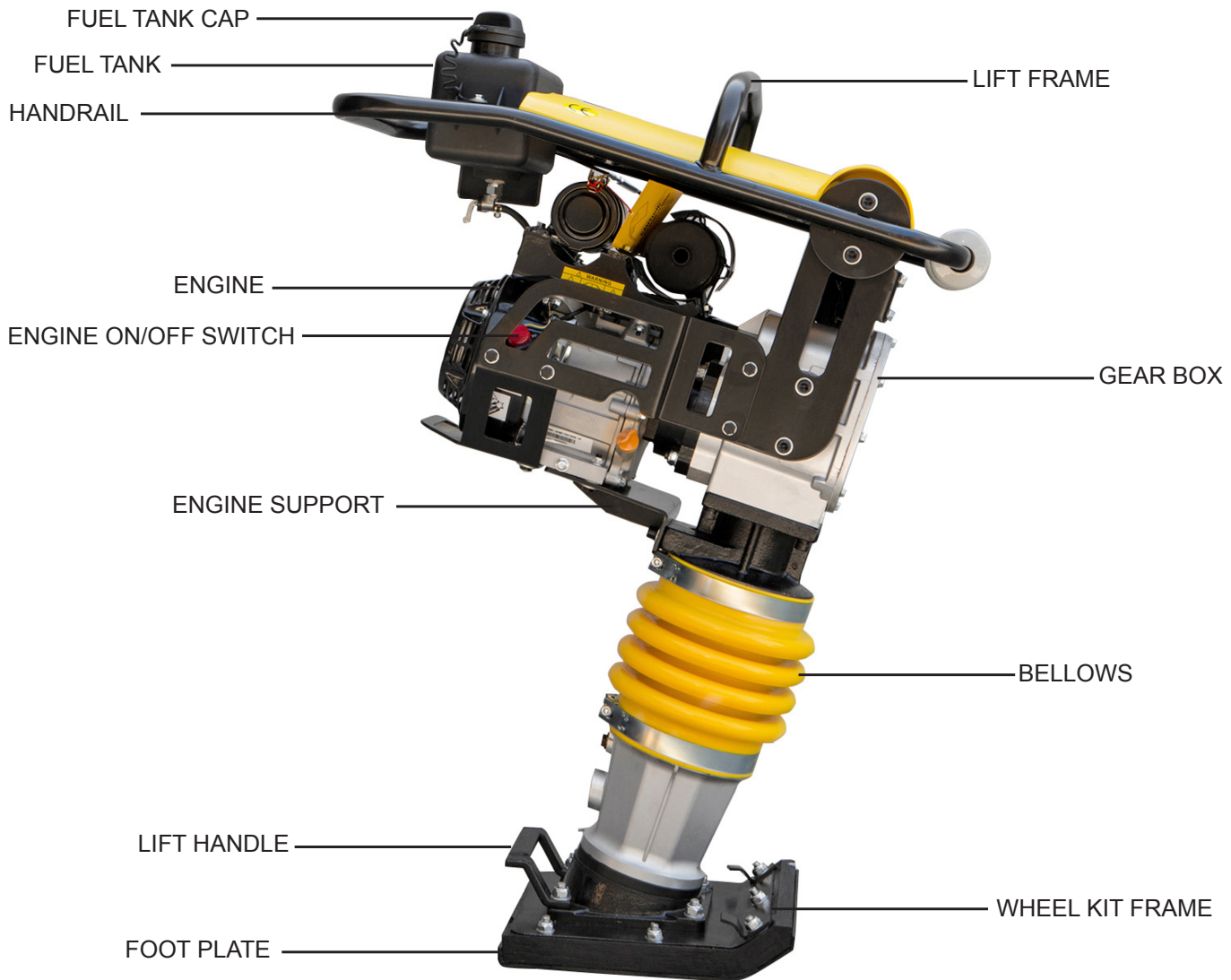

Compact the areas that you would like to work on with the STKUSA Compact Jumping Jack. This machine allows you to condense the flooring that you would be working on to help give the floor a firm and compact area for the material to sit atop. Create a firm ground in your home, yard, or street to help you place flooring that will not become loose and have perfect fitting on the floor.

FEATURES

- Ideal for compacting gravel, clay and sand in compactness of road, bridge foundation, house, reservoir dam, and narrow worksite
- Ramming Plate Size: approx. 330 mm x 290 mm; Percussion Rate (Ramming Frequency): 450~650 Times per Minute
- Engine Power: 6.5 HP 4 Stroke Recoil Start; Jumping Stroke (Leap Height): 40~65mm
- Impact Force Also Known “Ramming Force”: 10,000N
- EPA & CARB Approved

MAINTENANCE

- Close the rammer before performing any maintenance.
- In order to avoid that the engine starting unexpectedly, place the engine switch on the OFF position and pull out the connecting pipe of the spark plug.
- Be sure to maintain the rammer every time you use it and keep up with maintaining the rammer after 50, 100 and 300 working hours.
- Check whether the air cleaner filter is blocked or the sponge is broken. A dirty filter will block the air cleaner, which will weaken the engine even causing the engine to fail to start.
- Check the rammer for worn or damaged parts and that all screws and fasteners are tight. Replace any worn or damaged parts, screws, or bolts, etc., before use.

AFTER EACH USE, PERFORM THE FOLLOWING:

- Remove any foreign substances such as dirt or rocks from the rammer and engine.
- Clean the engine cylinder cleaning fans.
- Clean or repair the air filter.
- Check the general condition of the rammer for wear and/or damage. Order replacement parts prior to next use.

IF STORING FOR MORE THAN 30 DAYS, OR TRANSPORTING, PERFORM THE FOLLOWING:

- Drain the fuel tank completely.
- Check that the accelerator handle is in the idle position then start and run the engine until the fuel in the carburettor is completely consumed.
- Change the engine oil and follow the procedures in the engine manual for engine storage.
- If storing the rammer, place the rammer in a clean, dry area where it won't be knocked over and cover it with a cloth.
- If transporting the compactor: lift it by the top, center of the frame using a proper lifting crane when moving it on and off a truck. Lifting the compactor by hand may cause personal injury due to its heavy weight.

Maintain the rammer by adopting a program of conscientious repair and maintenance in accordance with the following recommended procedures.



Always put the engine On/Off switch in the off position and close the fuel valve before performing any maintenance on the rammer to avoid accidental engine starts. For added safety, remove the spark plug cap. Such preventive safety measures reduce the risk of starting the tool accidentally.

MAINTENANCE

PRODUCT SPECIFICATIONS

MODEL	R-80K IMPACTING RAMMER	RAMMING FREQUENCY	450 ~ 650 TIMES/MIN
ENGINE	GASOLINE ENGINE 3 ~ 6.5PS	RAMMING FORCE	10000N
LEAP HEIGHT	40 ~ 65mm	RAMMING PLATE SIZE	300 X 330mm
ADVANCING SPEED	10 ~ 13 m/mm	PACKAGE SIZE	717 X 525 X 1005mm
GROSS WEIGHT	88KG		

ENGINE MAINTENANCE SCHEDULE

Task \ Period		Daily before starting	Every month or 20 hours	Every three months or 50 hours	Every 6 months or 100 hours	Every year or 300 hours
Engine oil	Check oil level	●□□				
	Replace oil		●□□		●	
Air cleaner	Inspection	●□□				
	Clean			●		
Carburetor precipitation cup	Clean				● □	
Spark plug	Check and clean			● □		
Muffler	Clean				● □	
Air valve gap	Check and adjust					●□□
Oil tank and filter	Clean					●□□
Oil pipe	Check/replace as needed					●□□

NOTICE

The rammer is a vibratory machine and its bolts can unfix easily. Check and fasten them immediately and frequently. Because the influence of vibration, some parts of the rammer are damaged easily, such as the spring, protective cover, shock absorber and bearing etc. Be sure to check them frequently and replace immediately if they are damaged.

This machine has special requirements regarding lubrication. Because of the reciprocating motion of the protection cover, movement vat, connecting rod, pole core etc., it produces gas in the machine. This gas makes the lubricating oil atomizing and it can lubricate the upper gear, axle, bearing and sliding parts. So refuel the lubricating oil according to the standard. Because of the strong vibration of the rammer and attrition among parts of the rammer, it often produces residues. Be sure to replace the lubricating oil periodically.

MAINTENANCE

DISASSEMBLY OF THE RAMMER

1. First remove the handrail, then remove the fastening bolts of the gasoline engine and take down the gasoline engine. Lastly, let out the lubricating oil.
2. Remove the bolts that connect to the box and the movement vat, then rotate the hub and disassemble the clamping spring in the linchpin. Remove the linchpin and take down the box.
3. Disassemble the fastening circle in the protective cover and take down the movement vat, then remove the protecting cover.
4. Remove the elastic linchpin in the connecting base and separate the connecting base from the driving rod by rotating the connecting base.
5. Remove the bolts on the ramming plate and the bottom base, then disassemble the ramming plate.
6. Remove the bolts on the bottom base, which fasten the lower covering and take out the lower shell.
7. Remove the bolts on the bottom base, which fasten the inner vat and separate the bottom base from the inner vat.

TROUBLESHOOTING

PROBLEM	POSSIBLE CAUSE	SOLUTION
OIL LEAKAGE	Fastening bolts on connecting point are loose	Fasten the loose bolts
	There are sand and/or gas holes on the cast	Weld the holes or replace the cast
	The sealing parts are worn	replace worn parts or protecting cover
BOUNCE HEIGHT OF RAMMER IS SHORT	The spring is worn or fractured	Replace the spring
	The rotation speed of the engine is not enough	Accelerate the rotation speed of the engine
ABNORMAL BOUNCE OF RAMMER	The earth is too hard	Change the location
	The spring breaks off	Replace the spring
	Lack of lubricating oil	Add enough lubricating oil
	The rotation speed of the engine is too low due the throttle coming loose	Adjust the rotation speed of the gasoline engine or refuel
THE ENGINE WORKS BUT THE RAMMER ISN'T WORKING	The controlling switch of the throttle is not the proper position. The rotation speed of the engine is low	Adjust the ventilation door or aggrandize the throttle to accelerate the rotation speed
ENGINE DOES NOT START	There is no fuel in the tank	Supply fuel
	The fuel valve is closed	Open the fuel valve
	Engine stop switch is OFF	Turn switch to ON
	There is no oil in the carburetor	Supply oil
	The spark plug is broken or has too much carbon deposit	Clean the spark plug or replace it.
	The fuel filter is plugged	Clean the fuel filter or replace it (see engine manual)
ENGINE DOES NOT ACCELERATE OR RUNS POORLY	The spark plug is fouled.	Clean the spark plug or replace it.
	The air filters are dirty	Clean the air filters or replace them.
	Carburetor cannot supply oil freely	Clean the carburetor
	Piston ring, air door wired	Refer to the engine manual.
ENGINE RUNS BUT RAMMER DOES NOT TAMP	Clutch worn out	Replace the clutch
	The connecting rod or gear is broken	Replace the rod or gear
	There is too much oil in the ramming system	Remove some of the oil
ENGINE RUNS BUT RAMMER JUMPS ERRATICALLY	Nuts/fasteners in the transmission or rammer are loose	Check all nuts and fasteners and tighten any that are loose
	Spring in the rammer is broken	Replace the spring
	The engine speed is too low	Set the accelerator handle to full running position

WARRANTY

PLEASE READ THE FOLLOWING CAREFULLY

THE MANUFACTURER AND/OR DISTRIBUTOR HAS PROVIDED THE PARTS LIST AND ASSEMBLY DIAGRAM IN THIS MANUAL AS A REFERENCE TOOL ONLY. NEITHER THE MANUFACTURER OR DISTRIBUTOR MAKES ANY REPRESENTATION OR WARRANTY OF ANY KIND TO THE BUYER THAT HE OR SHE IS QUALIFIED TO MAKE ANY REPAIRS TO THE PRODUCT, OR THAT HE OR SHE IS QUALIFIED TO REPLACE ANY PARTS OF THE PRODUCT. IN FACT, THE MANUFACTURER AND/OR DISTRIBUTOR EXPRESSLY STATES THAT ALL REPAIRS AND PARTS REPLACEMENTS SHOULD BE UNDERTAKEN BY CERTIFIED AND LICENSED TECHNICIANS, AND NOT BY THE BUYER. THE BUYER ASSUMES ALL RISK AND LIABILITY ARISING OUT OF HIS OR HER REPAIRS TO THE ORIGINAL PRODUCT OR REPLACEMENT PARTS THERETO, OR ARISING OUT OF HIS OR HER INSTALLATION OF REPLACEMENT PARTS THERETO.

Record Product's Serial Number Here: _____

Note: If product has no serial number, record month and year of purchase instead.

Note: Some parts are listed and shown for illustration purposes only and are not available individually as replacement parts.



SAVE THESE INSTRUCTIONS.

Questions, Problems or Missing Parts?

Before returning to a retailer, our exceptional customer service is available to help.

Call Us: 909.628.4900

Hours of Operation: 9 to 4pm PST, Monday - Friday

Email: info@starktoolsusa.com

PRODUCT MADE IN CHINA