

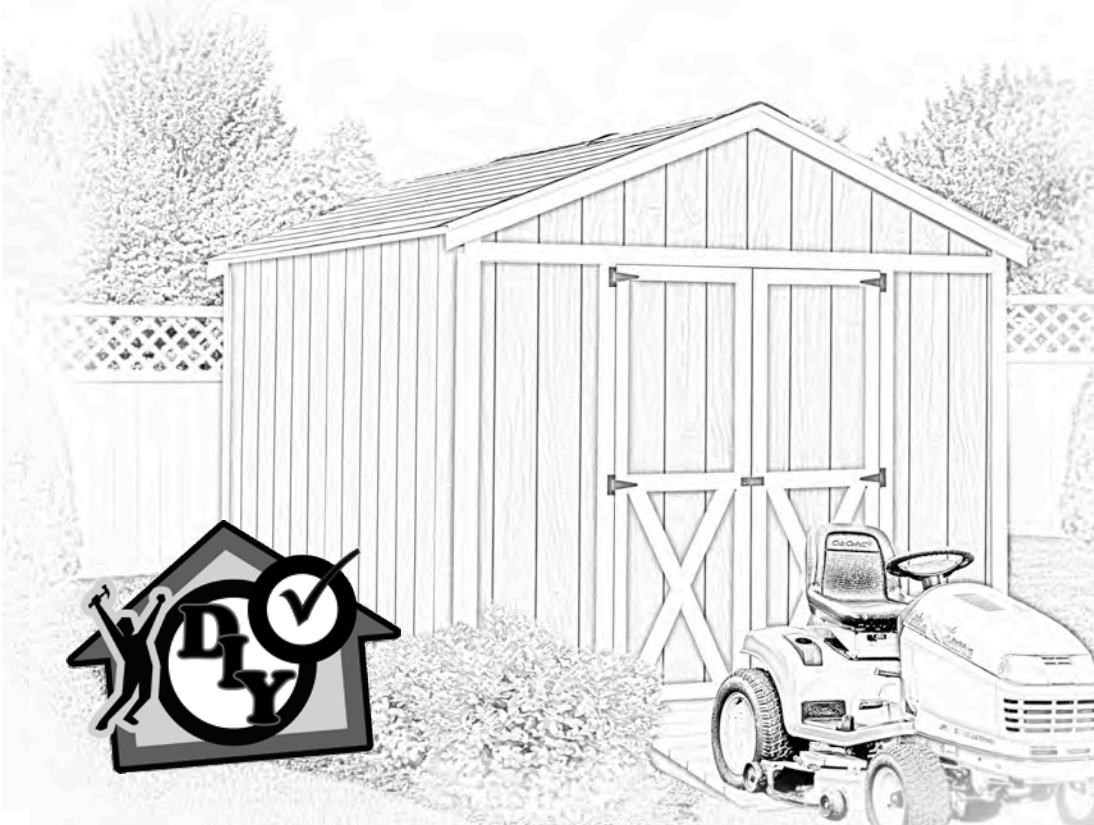

Best Barns USA

Assembly Book

Revised September 30, 2016



the Danbury - R 8' x 12'

Manufactured by Reynolds Building Systems, Inc.

205 Arlington Drive Greenville, PA 16125 724-646-3775

This manual is copyrighted. Under the copyright laws, this manual may not be copied, in whole or in part, without consent from Reynolds Building Systems, Inc. © Copyright 2011

IMPORTANT INFORMATION ABOUT YOUR SHED KIT

Thank you for purchasing our Danbury shed kit. The floor size should measure 8'-0" wide by 11'-9". **Do Not** make the foundation larger than the building size. The siding should project beyond the foundation for water to expel properly from the sidewalls.

The material that is included in our kit is listed on the back page. The optional floor package, *if ordered*, will be supplied by a local supplier.

Our kit does not include the shingles, the quantity needed is listed on the back page. The siding is primed. You will need to apply a finish coat using latex acrylic paint.

Some 2x4s was used in the shipping pallet. Unpack the material from the pallets, then unscrew the (4) four 2x4s. The bit for the screws is packed in the hardware bag. This material will be used for tie plates installed in **Step 7**. The OSB sheet will be used for roof sheathing.

Stacking the boards, according to size, will make them easier to find when needed. Some boards have colored ends. **Do Not** discard any material until your building is complete.

If you have any questions about assembling the kit, call 800-245-1577. If you are calling after normal business hours, call 724-866-HELP (4357) or email to help@barnkits.com.

Before you begin construction obtain a building permit and check all pertinent building codes.

Thank you for your purchase.

Siding Information

Siding panels have grooves cut into the face. To identify which edge we want you to use, we will refer to the edge as either the 'LAP' Edge or the Tongue Edge.

Use 8d galv. nails. Space nails 12" apart. The siding is primed. You will need to apply a finish coat using latex acrylic paint.

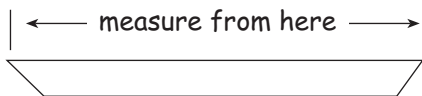
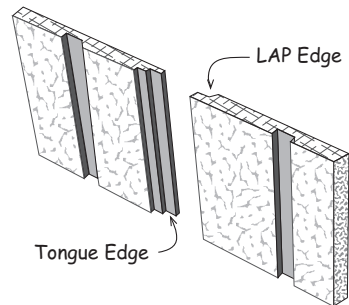

When measurements are given for a board length, it is from the longest side.

Tool List

- | | |
|--|--|
| <input type="checkbox"/> Hammer & Phillips Screwdriver | <input type="checkbox"/> Power Drill/Screwdriver |
| <input type="checkbox"/> Framing Square & Level | <input type="checkbox"/> Measuring Tape |
| <input type="checkbox"/> Hand Saw | <input type="checkbox"/> 2-6' Step Ladders |

Always wear safety glasses when cutting or nailing!

Constructing Details for Deluxe Floor System

Deluxe floors include 4x4 runners, standard floors do not



The floor should measure 8'-0" wide by 11'-9" in length. If you ordered the optional wood floor, follow the instructions below. When using a concrete slab for a floor install foam sill sealer as a moisture barrier between the concrete and the wall plates.

1. Cut (2) two 2x4-12' boards to 11' - 9". Layout boards for floor joist spacing. 'X' marks where floor joist will be placed.

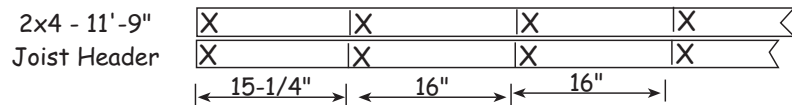

2. Cut 2x4-8' floor joist to 7'-9". Treated lumber may be thicker than 1-1/2". Shorten joist measurements if necessary to obtain 8'-0" building width.
3. Install floor joist between the joist headers. Use 16d galv. deck nails.

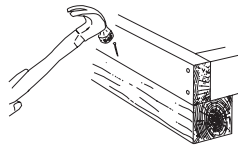
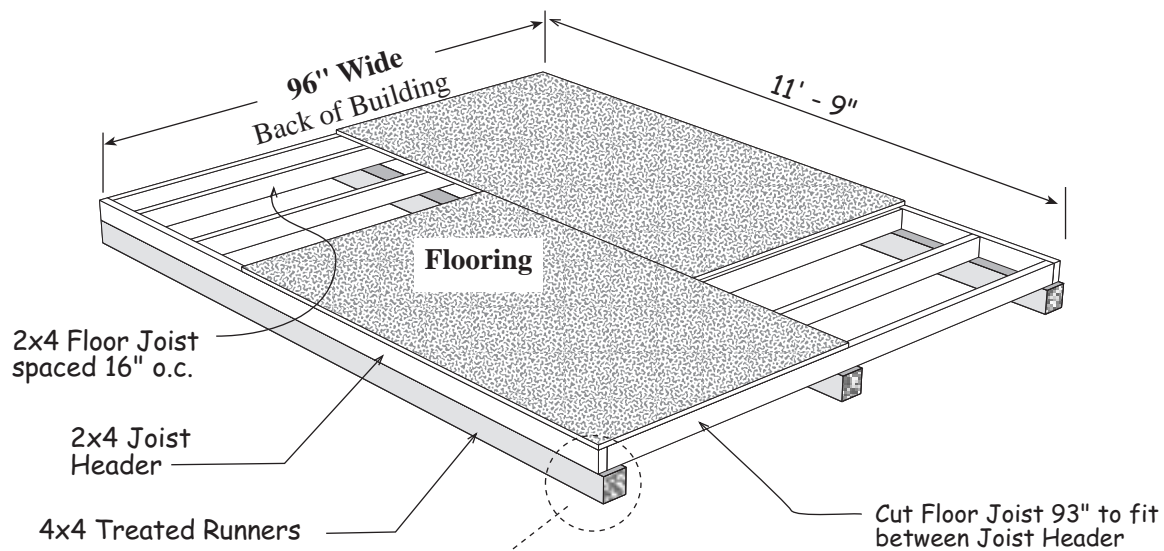

It is important that the floor be level and square. Before nailing the flooring, measure the floor diagonally (corner to corner). Then measure the opposite corners. These measurements will be the same if the floor is square. Angle measurement should be 170-1/2"

Material Description	8' x 12' shed	
2x4 Joist Headers	2 pcs.	12'
2x4 Floor Joist	10 pcs.	8'
4x4 Treated Runners	3 pcs.	12'
Flooring 5/8" or 3/4"	3 pcs.	4x8
Screw Floor Nails	1 lb.	8d
Galv. Box Nails	1 lb.	16d

Step 1 Assemble Roof Trusses

 It is important that all the trusses be assembled the same. While assembling first truss use 10d sinkers to tack short 2x4 packing blocks around the top to insure that all the trusses are assembled the same.

1. Temporarily install a 2x4-8' board, *to the end of the floor*, extending 1-1/2" above the surface of the floor . Use 2-1/2" screws.
2. Position two 52" long 2x4 truss rafters together Secure the tops together with a wood gusset. Nail the wood gusset with (10) ten 6d common nails. Do Not attach the truss rafters to the bottom 2x4 board. Apply wood gusset to the opposite side.
3. Assemble (4) four more trusses.

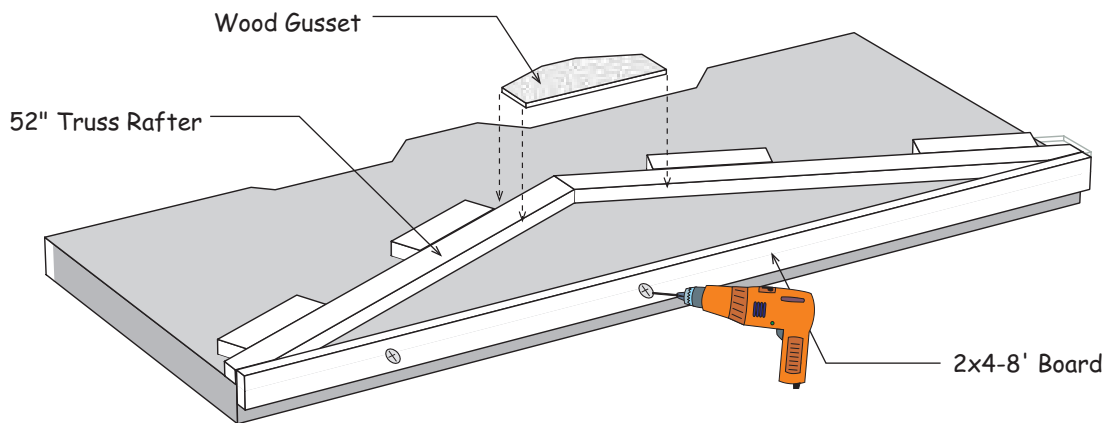

4. When assembling the last truss, install a 2x4-6' board across the truss. Insure top of 2x4 is flush with top of truss rafters. Secure with 10d sinkers.

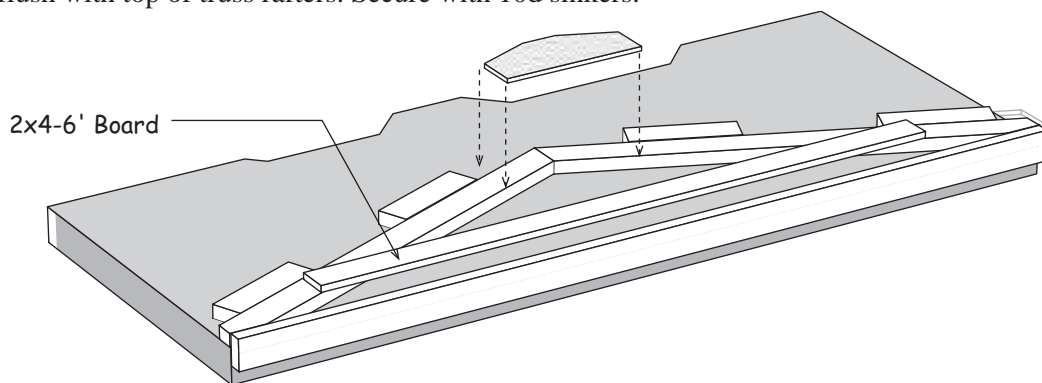

Set trusses aside, leaving the 2x4-8' board attached to the floor.

Step 2 Assemble Gables

1. Position two 52" long 2x4 truss rafters together
2. Install a 18-7/8" long 2x3 gable stud, with a pointed end, in the center. Secure the bottom by screwing through the bottom 2x4-8' with 2-1/2" screws.
3. Secure rafter ends to 2x4-8' using 2-1/2" screws.

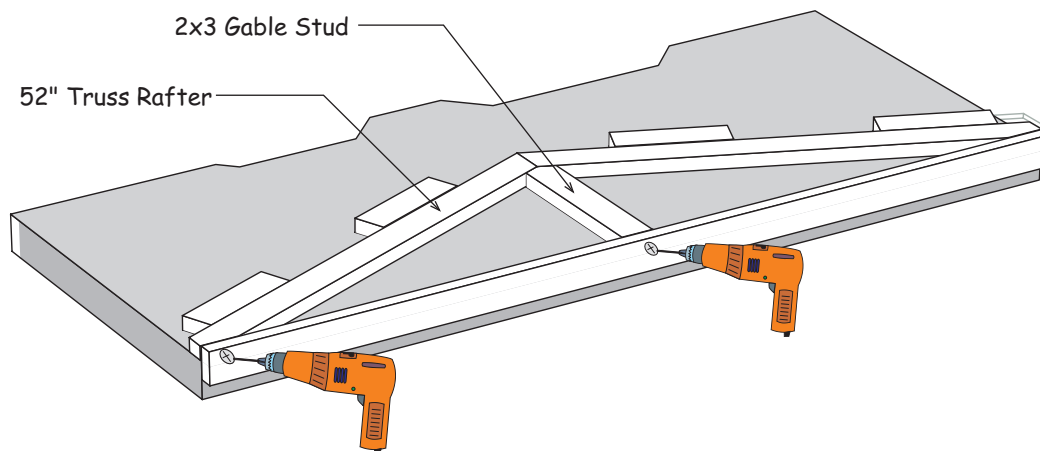

4. Install gable siding over the gable frame. Use 6d galv nails spaced 12" apart. The siding will be flush with the top of the 2x4 frame and extend below the gable frame.

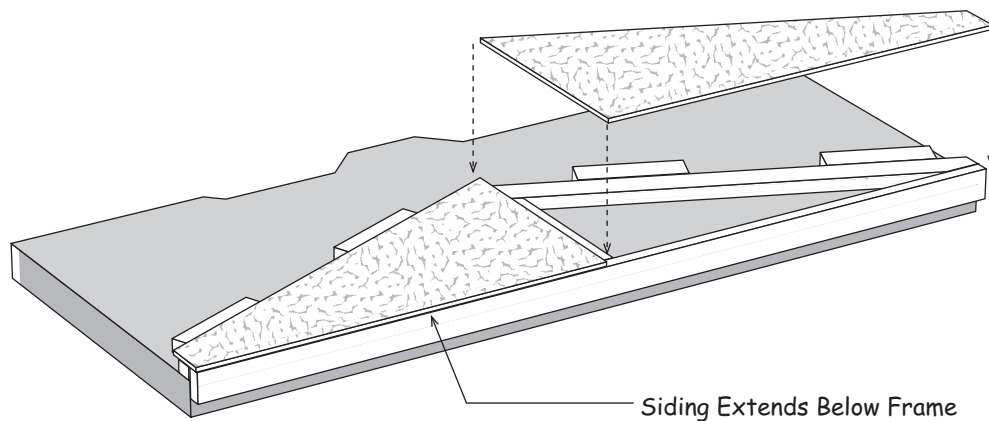

5. Unscrew the bottom 2x4-8' from floor and remove the gable frame.
6. Assemble another gable using another 2x4-8' board and truss parts.

Step 3 Assemble Back Wall

1. Gather (2) two 2x4-8' boards. Layout boards for wall stud spacing. 'X' marks where the wall studs will be placed.

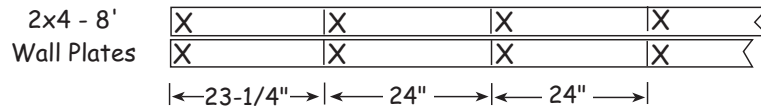

2. Install 72" wall studs between the top and bottom plates. Secure studs with 10d sinkers, two (2) nails at each stud end.

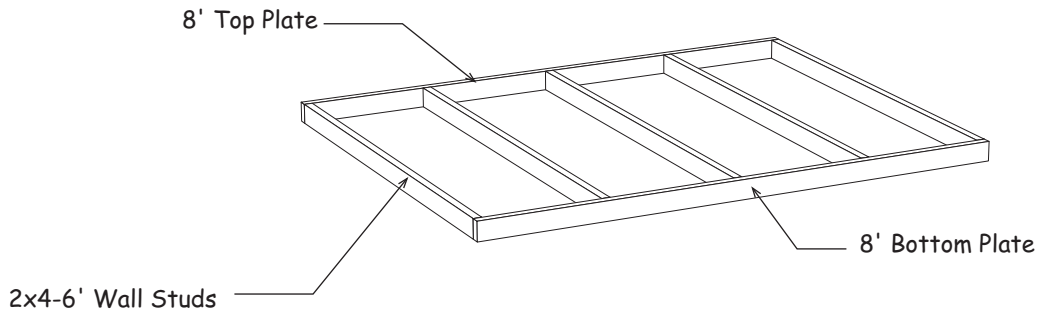

3. Square wall frame. *Measure diagonally (corner to corner). The measurements will be the same when the wall is square.*
4. Locate (2) two 48" x 75-3/4" siding panels. Install the 1st. panel with the 'LAP' edge flush with the end and top of the wall frame. Install siding with 8d galv. nails. Space nails 12" apart.
5. Install the 2nd. siding panel.

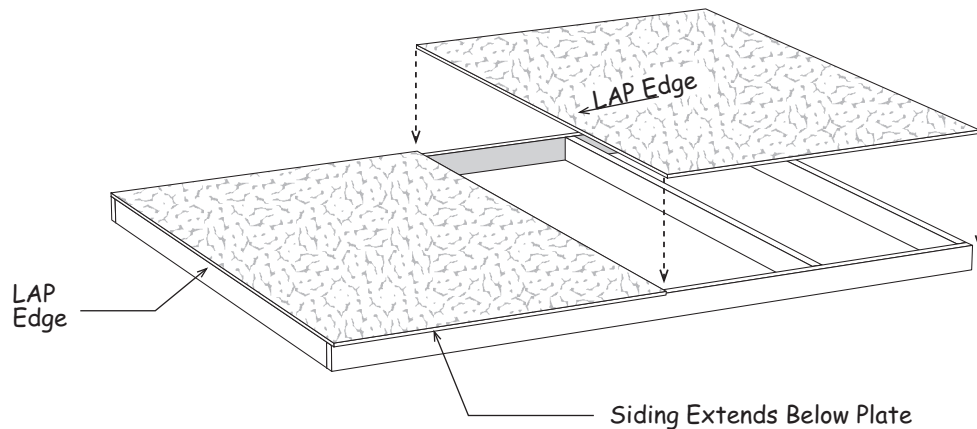

Step 4 Assemble Frontwall

1. Using measurements in illustration below install (4) four 2x4-72" wall studs between (2) two 2x4-8' plates with 10d sinkers.
2. Square wall frame.

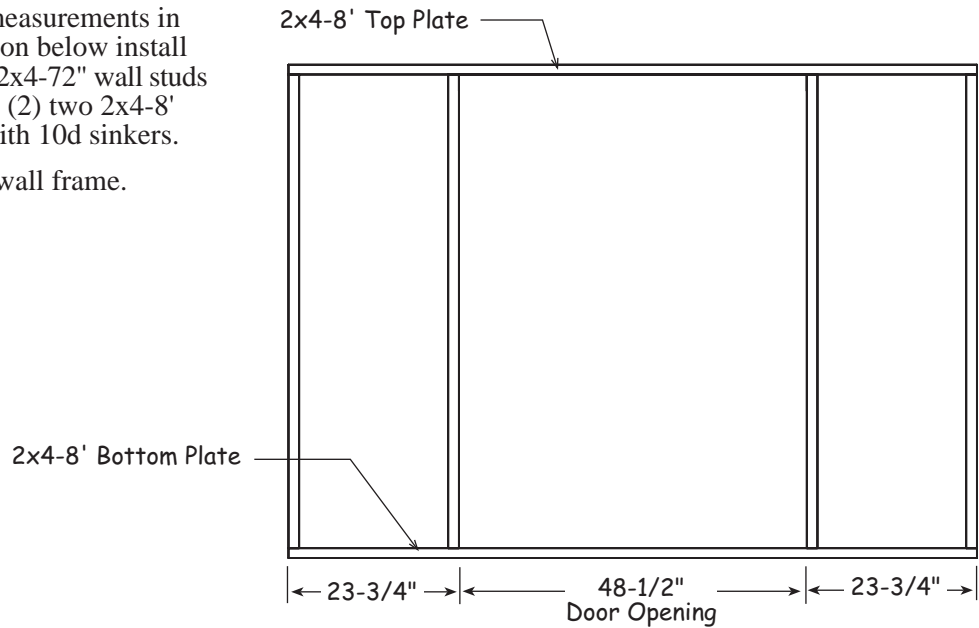

3. Install a $23\text{-}3/4\text{'}$ x $75\text{-}3/4\text{'}$ wall siding with 'tongue' edge flush with the door opening and cut edge flush with top plate.

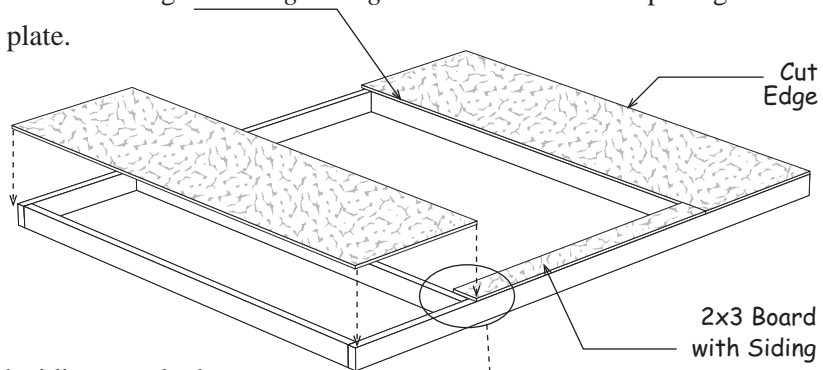

4. Install a 2x3 board, with siding attached, at the top of the wall frame.
5. Install another $23\text{-}3/4\text{'}$ wide siding with 'lap' edge flush with door opening and cut edge flush with top plate.

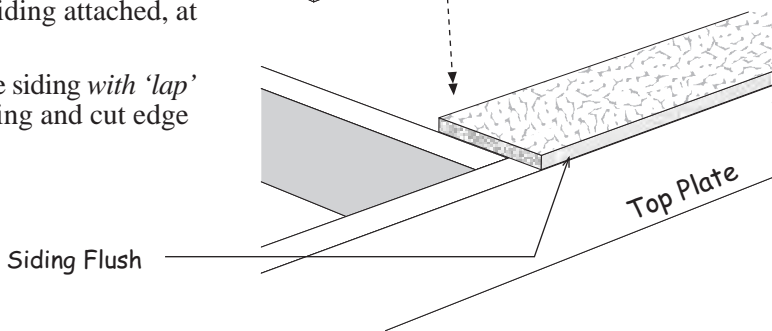

Step 5 Assemble Sidewalls

1. Position 68-1/2" and 65-1/2" boards together and indicate with 'X' marks, where the wall studs will be located. Mark the ends that will butt together with the letters 'A' and 'B'.

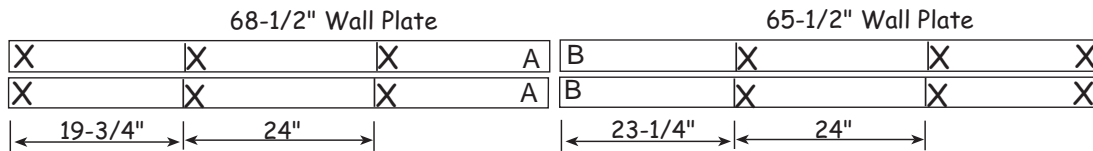

2. Install 72" wall studs between the top and bottom plates. Assemble wall frames with 10d sinkers. Nail both wall frames together.

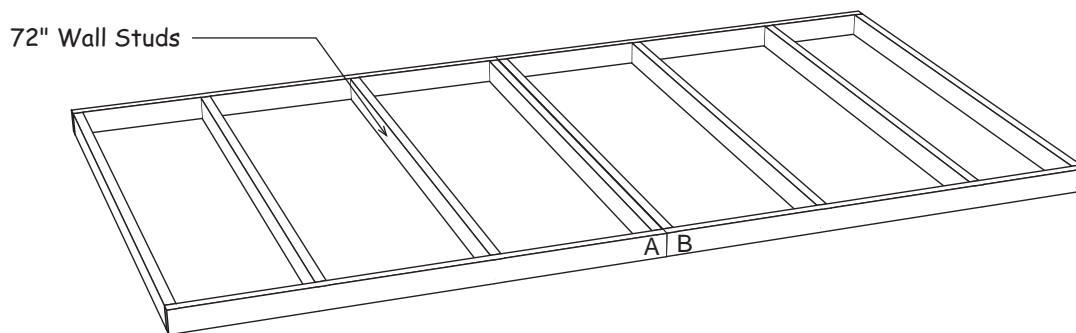

3. Square wall frame. Angle measurement is 153-1/2" when squared. Install (2) two full width siding panels. Install the first siding panel with the 'LAP' edge extending 3-1/2" past the end of the wall frame. Insure siding extends 3/4" below the bottom plate. Siding will extend above top plate.
4. Install a 45" wide siding panel last. The panel will extend 3-1/2" past the wall frame.

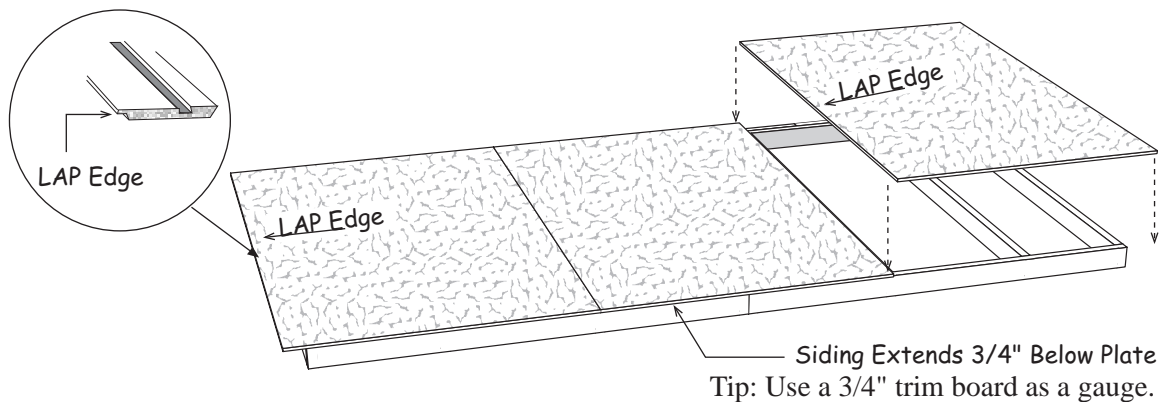

5. Repeat steps to assemble another sidewall panel.

Step 6 Set Wall Panels

1. Nail wall panels together using 10d sinkers (4) four per corner. Secure panels to floor.

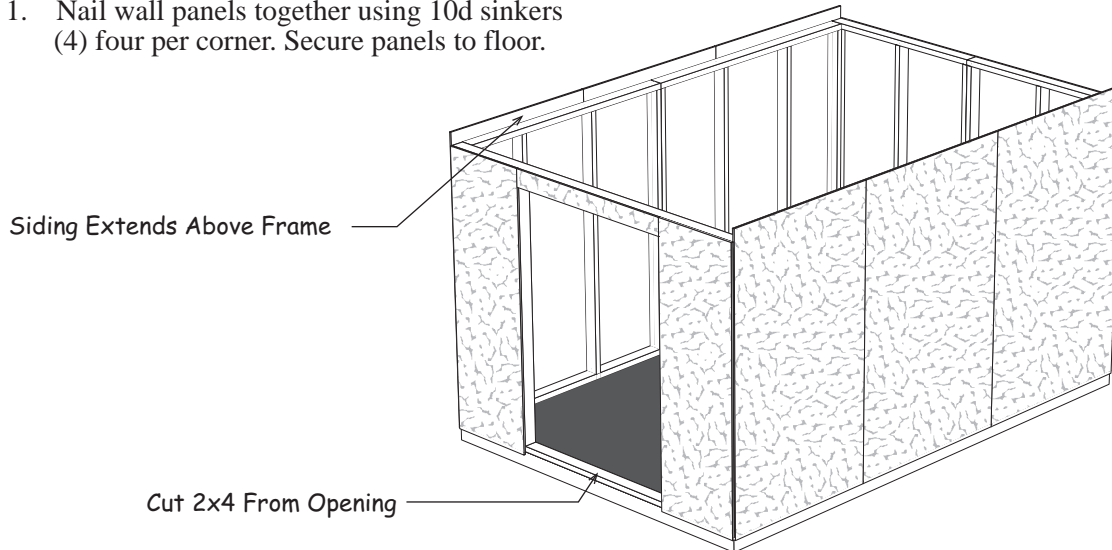

2. Install 1x4-75 3/4" trim boards at the front corners. Install the trim flush with siding on the sidewalls. Use 8d galv. nails, spaced 12" apart.
3. Cut a 1x4-8' trim board and install between the corner trim, flush with the top of the wall plate.
4. Repeat steps to install trim at the rear of the building.

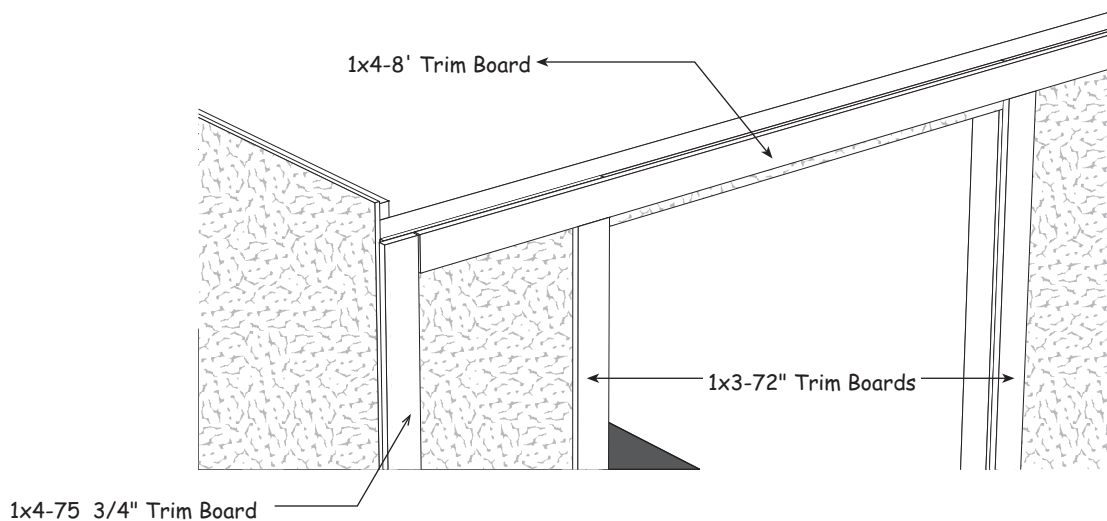

5. Install 1x3x72" boards along each side of the door opening. Tack these boards with a couple nails; you may want to move the trim later when you install the doors.

Step 7 Set Roof Gables

1. Install the rear gable on the back wall. The gable siding will extend over the 1x4 trim on the lower wall. **NOT behind the trim!** Secure gable to wall by nailing through the gable plate with 10d sinkers. Nail siding along the 1x4 trim board with 6d galv. nails.

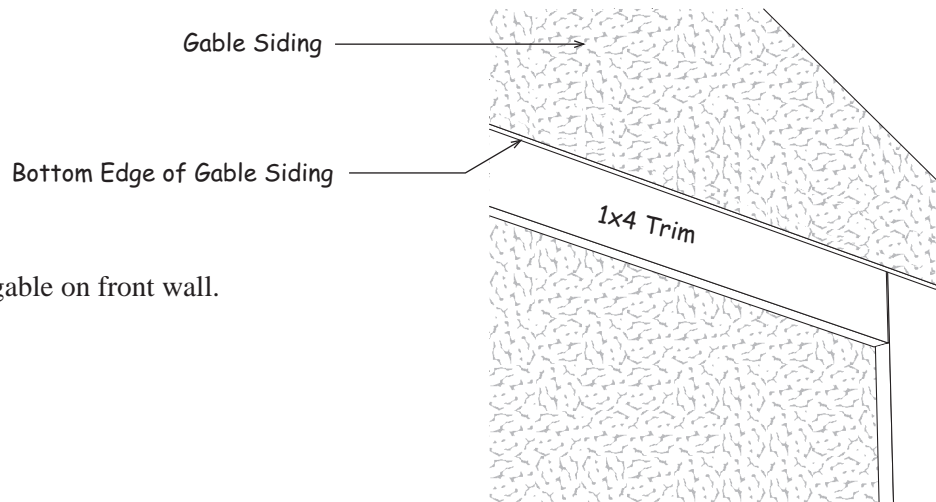

2. Install gable on front wall.

3. Install the 2x4s, removed from the shipping pallet, as tie plates on the sidewalls. Install a long 2x4 in the center of the wall overlapping where the side walls butt together. Cut shorter 2x4s to fit between the center 2x4 and the gable.
4. Repeat to install tie plates on the opposite side.

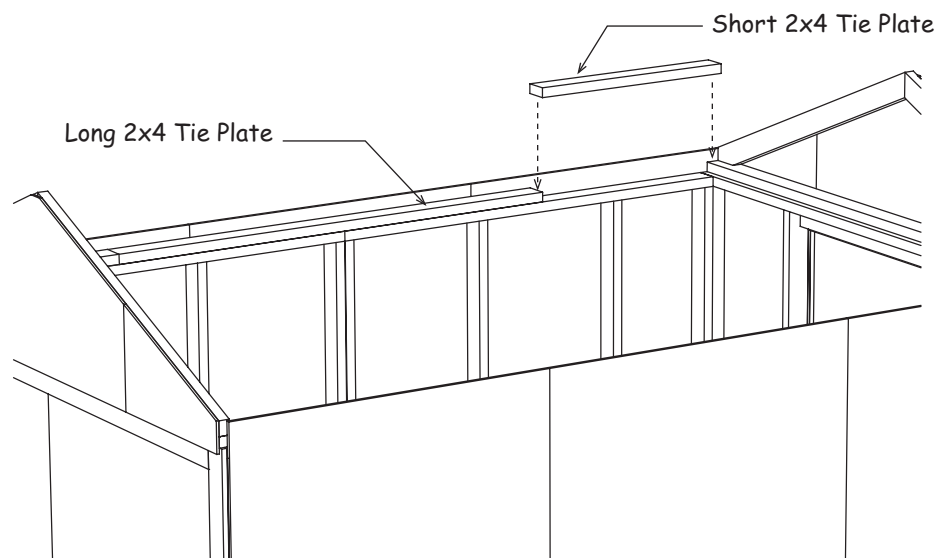

Step 8 Set Trusses

1. Starting at the back of the building. Set the first truss with a $21\text{-}\frac{3}{8}$ " space between the truss and the rear gable.
2. Set the remaining trusses. The space between the trusses should be $22\text{-}\frac{1}{2}$ ". Install the truss with the 1x4 collar tie in the center of the building.

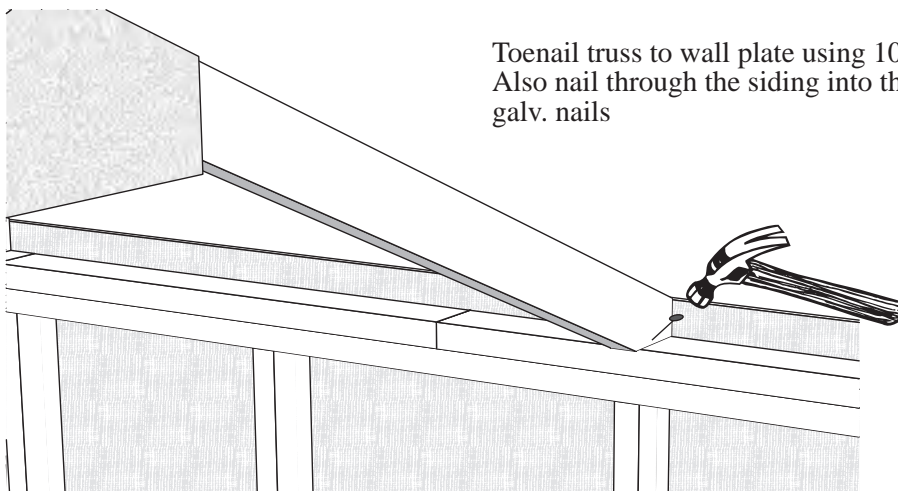
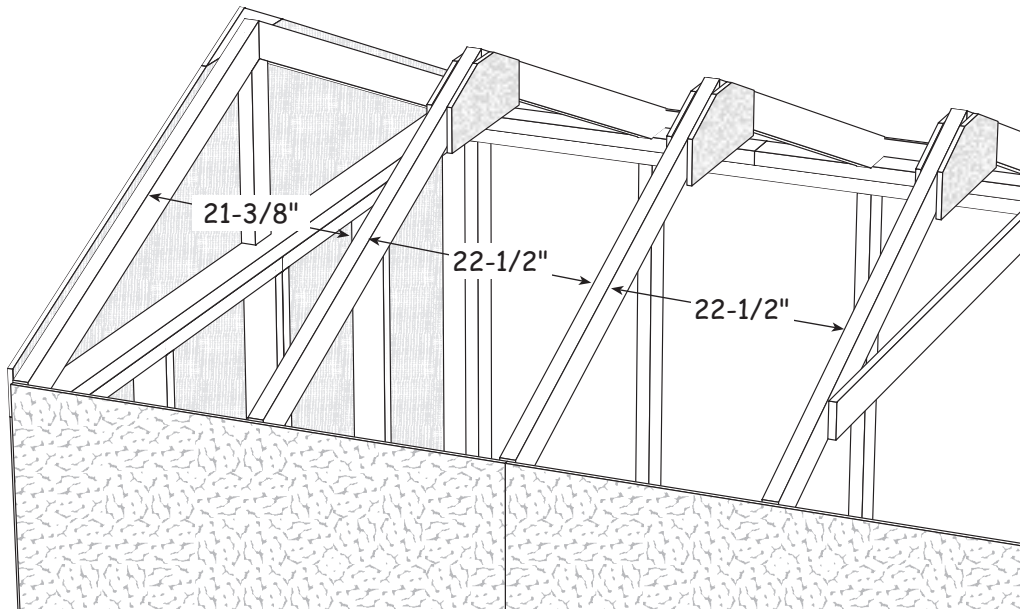

Toenail truss to wall plate using 10d coated nails.
Also nail through the siding into the truss with 8d galv. nails

Step 9 Install Roof Sheathing

1. Install the roof sheathing per the layout below. Starting from back gable install 48"x72" sheathing flush with gable siding and 1" past siding on sidewall. Install 8-1/2"x48" sheathing applying Plyclip as described below. Sheathing will be below peak of trusses approximately 1-1/2". Use 7d sinkers, space nails 12" apart.

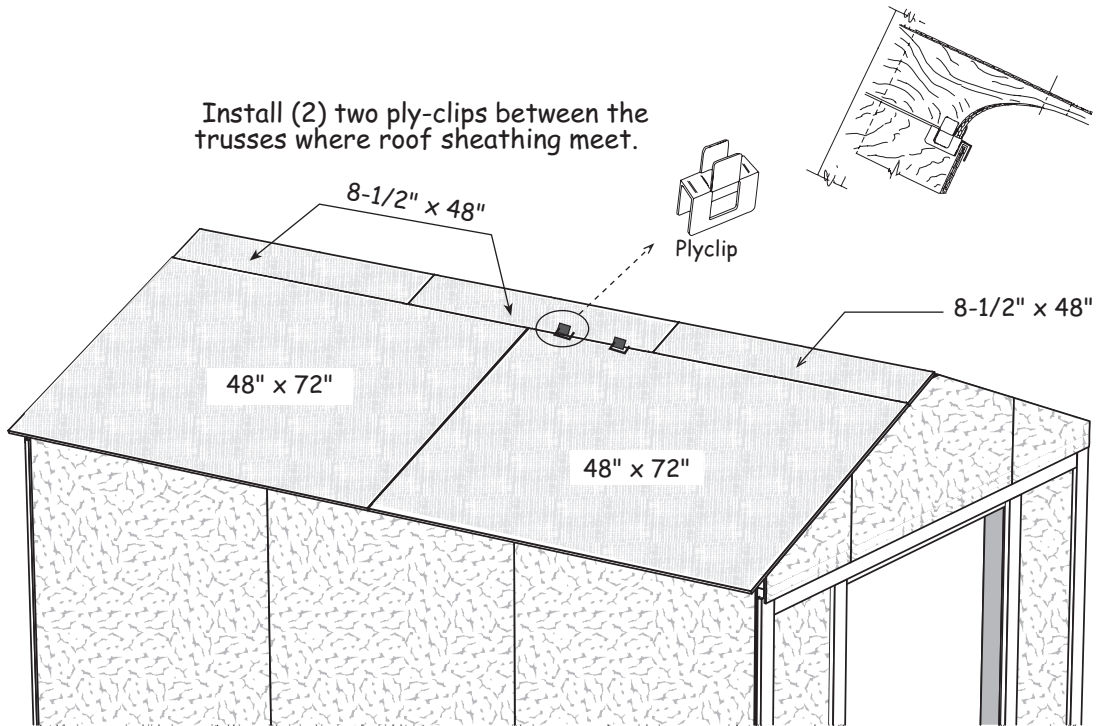

Step 10 Install Gable Trim

1. Install 1x4 gable trim at the front and back of the building. Top of trim will be flush with roof sheathing.

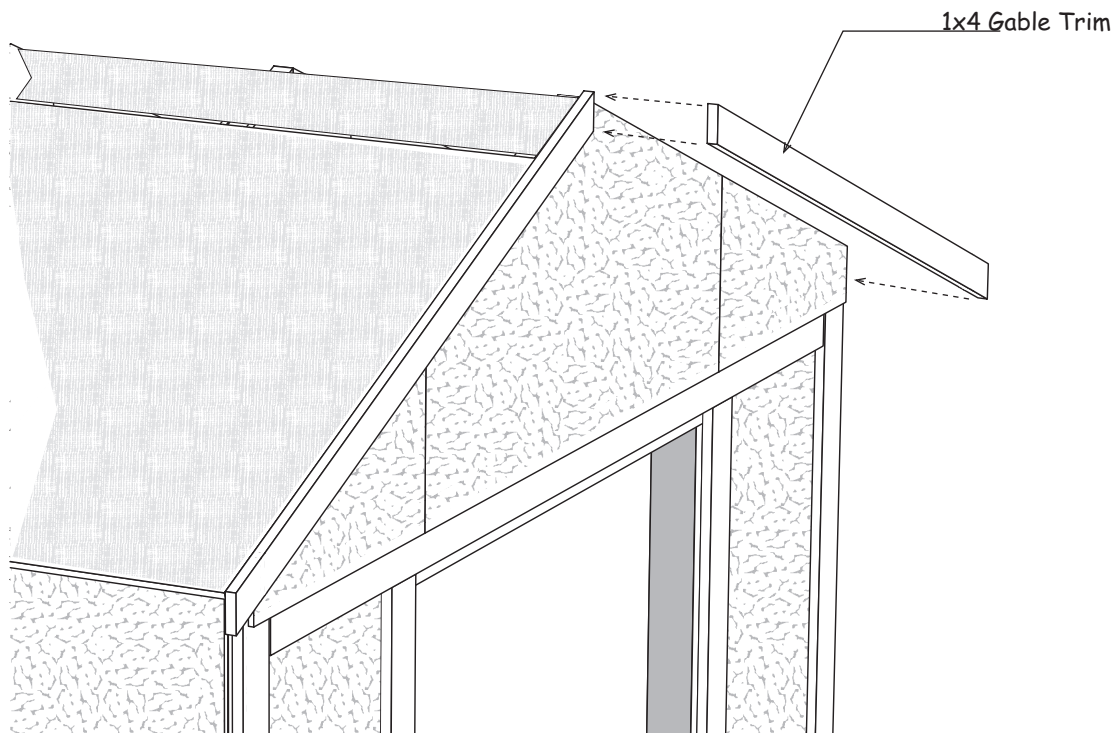

Step 11 Install Door Hinges

1. Place the left door with the trim facing up. The left door has a 2x4 door stop installed on the back, see **Step 13**.
2. Install 4" hinges to the left side of the door frame. To position the hinge properly, hold the rectangular plate against the frame.
3. Install hinges to the right side of the other door.

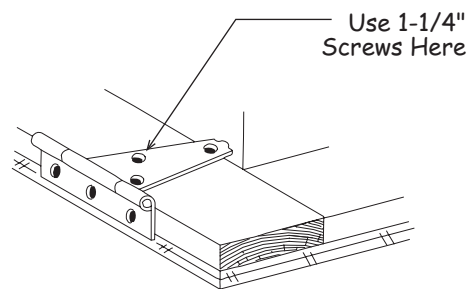

Step 12 Install Doors

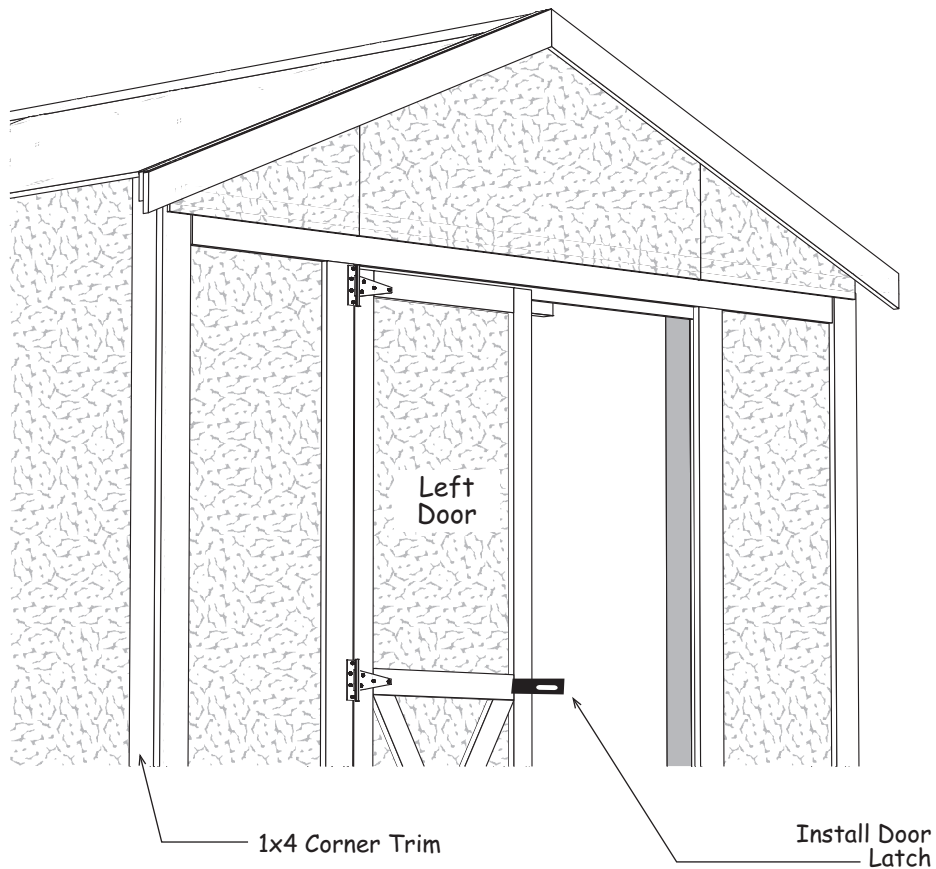

1. Install 1x4 corner trim on the side walls.
2. Before you fasten the hinges to the door trim, temporarily prop the doors in the opening. Leave a space between the doors and the side trim to allow room for the doors to expand when they absorb moisture.

If your door opening is out of square, the space around the doors will not be even. You can remove and reposition the side trim to make allowances for this. The side trim does not have to be flush with the frame of the door opening. You can move the trim in or out to make the door spacing equal. Adjust trim, if necessary, and then secure with 8d galv. nails. Secure hinges to the door trim with 2" long screws.

3. Install door latch.

Step 13 Install Barrel Bolt

1. Install a barrel bolt, on the lower back of the left door to secure this door in place when closed. You will need to drill a hole for the round shaft to drop into. Install another at the top of the door.

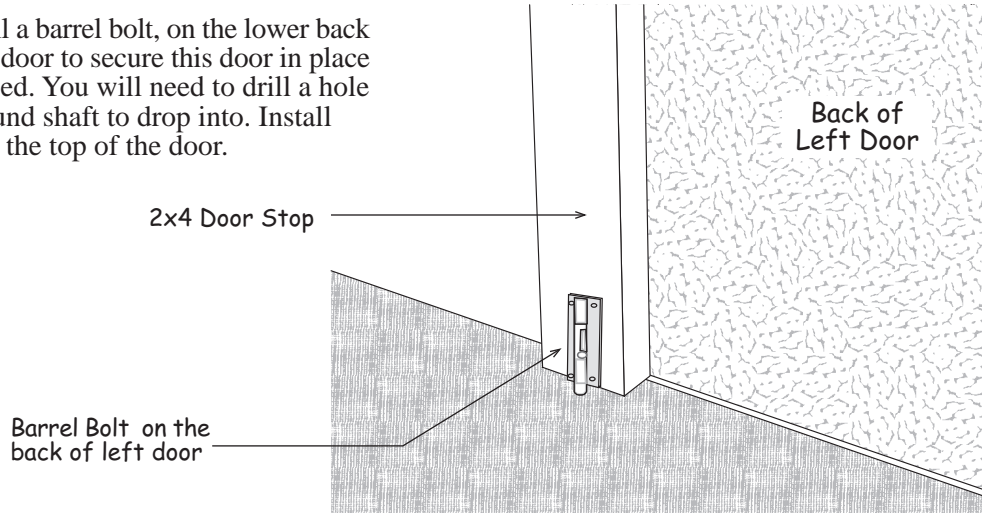

Step 14 Install Roofing — Not Supplied in Kit

1. Install metal roof edging perimeter of the roof area.
2. Install shingles according to the instructions on the wrapper. If you need more detailed instructions on installing shingles, there are good publications at book stores or newsstands.

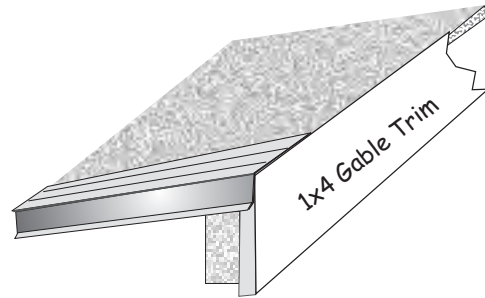

Building Tip: Install ridge vent in lieu of shingles caps. Ridge vent provides ideal ventilation, preventing heat and moisture from damaging your building or its contents.

Optional ridge vent provides ideal ventilation.

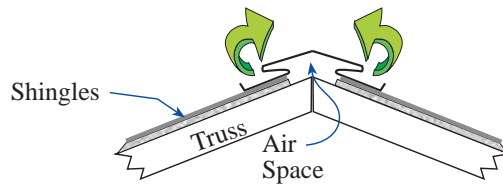

Danbury 8'x 12' Barn kit

Packing List

Qty.	Description	Size
	2x4 Framing	
4	Tie Plates (attached to pallet)	80 "
14	Truss Rafters	52 "
6	Plate Material	96 "
26	Wall Studs	72 "
4	Plate Material	68 1/2"
4	Plate Material	65 1/2"
4	Tie Plate Material	48 "
	2x3 Framing	
1	Door Header w/ siding	48 1/2"
2	Gable Studs	18 7/8"
	LP Exterior Siding	
4	Pcs. 48" x 79-1/4" Sidewall Siding	
2	Pcs. 45" x 79-1/4" Sidewall Siding	
2	Pc. 48" x 75-3/4" Back Wall Siding	
2	Pcs. 24" x 75-3/4" Front & Back Walls	
4	Pcs. Gable Siding	

Qty.	Description	Size
	White Pine Trim	
4	1x4 Gable Trim	57 3/4"
4	1x4 Corner Trim	78 3/8"
4	1x4 Corner Trim	75 3/4"
2	1x4 Door Side Trim	72 "
2	1x4 Lower Gable Trim	96 "
2	24" Wide Barn Doors	24" x 72"
	Hardware	
2	lb. 10d Sinkers	36 Hinge Screws
1	lb. 7d Sinkers	6 4" Hinges
1	lb. 8d Galv.	1 4" Door Hasp
1	lb. 6d Galv.	2 Barrel Bolts
1	lb. 6d Common	24 7/16" Plyclips
	7/16" Roof Sheathing	
6	8-1/2" x 48"	4 48" x 72"
	7/16" Wood Gussets	
10	8" x 12" Wood Gussets	

You will need to purchase. →

- 5 Bundle roof shingles with nails.
- 5 Pieces roof 'drip' edge.