



instant post holes

OZCO BUILDING PRODUCTS

Product & Packaging Specs

34" 4X4 Post Anchor (T4-850)

Item #: 30160

ITEM NO.	QTY.	PART NUMBER	DESCRIPTION
1	1	30160-11	Assembly, Base Anchor
2	1	30160-13	Base, 4x4 Post Anchor Wood

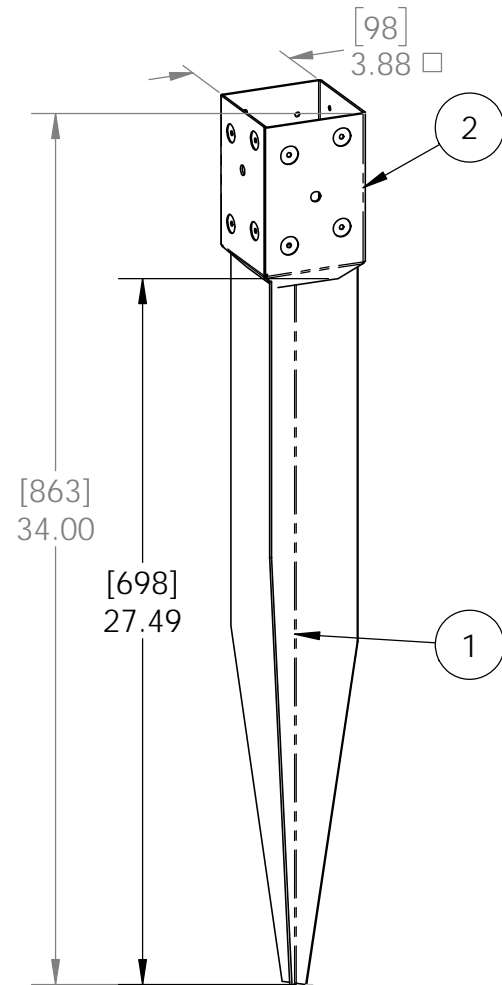
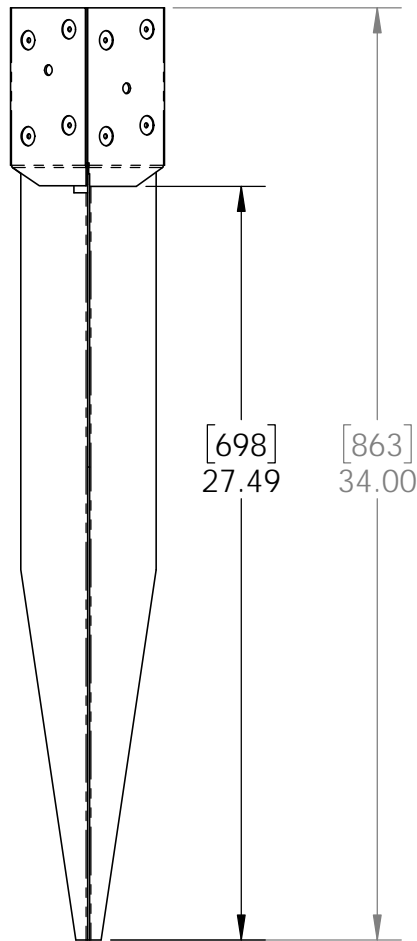
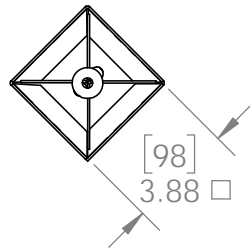
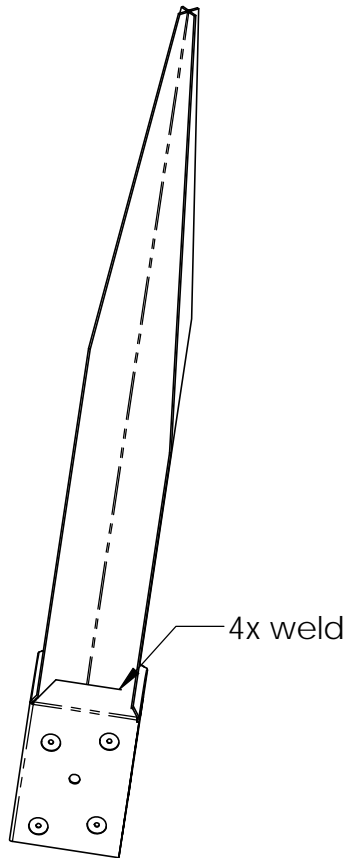

Weight: 7.24 LBS
 Scale: 1:7
 Last updated: 10/14/2016

30160-10



Product & Packaging Specs

34" 4X4 Post Anchor (T4-850)

Item #: 30160

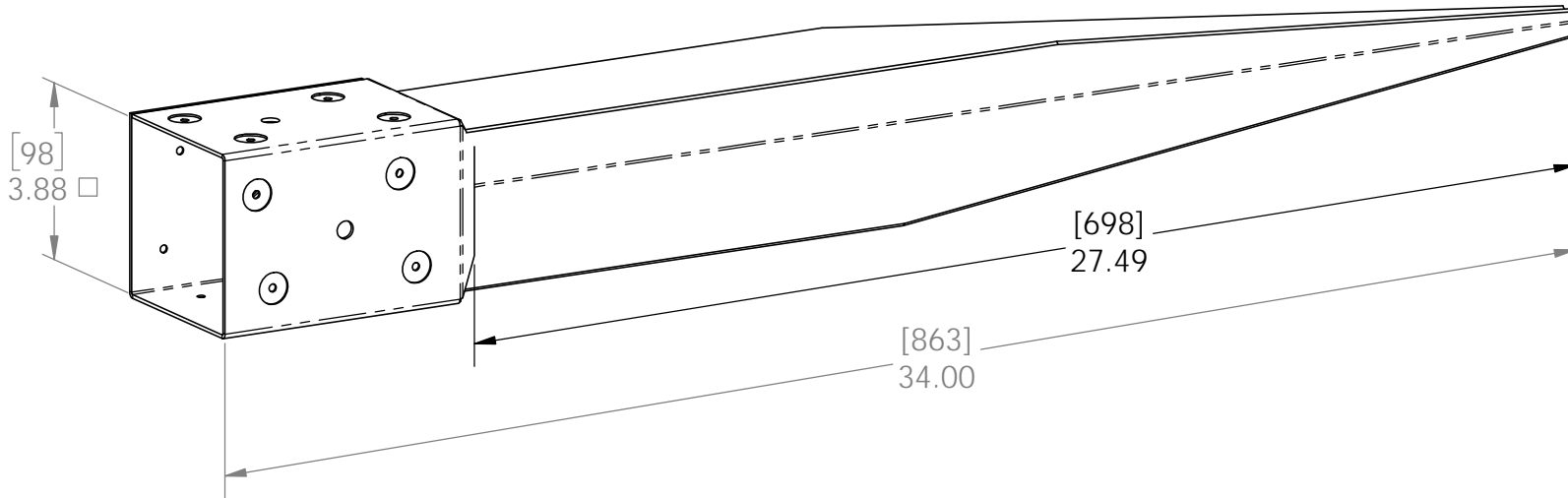

Weight: 7.24 LBS
Scale: 1:4
Last updated: 10/14/2016

30160-10

OZ-POST

instant post holes

OZCO BUILDING PRODUCTS

Product & Packaging Specs

34" 4X4 Post Anchor (T4-850)

Item #: 30160

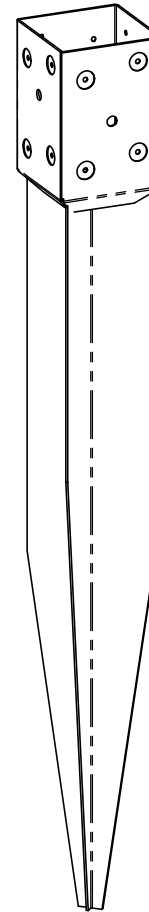
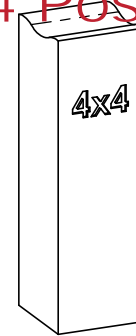
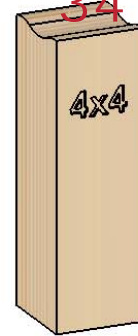
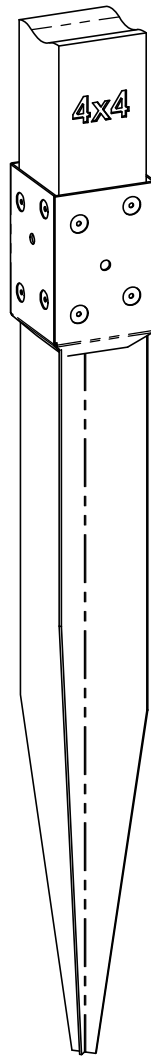
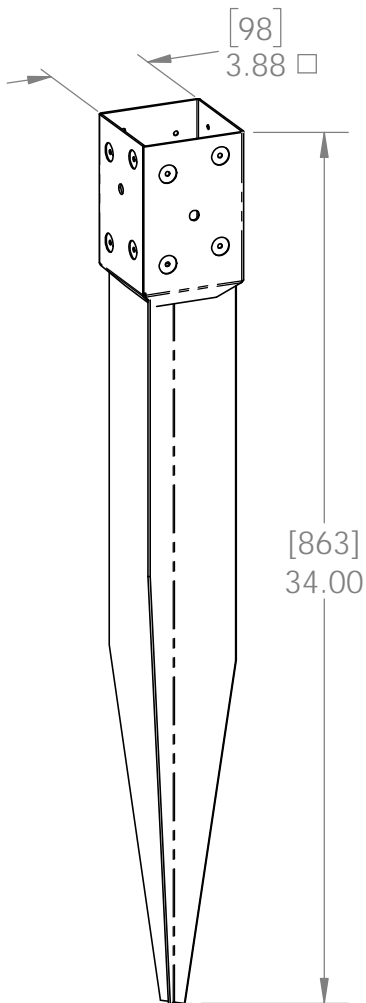

Weight: 7.24 LBS
Scale: 1:7
Last updated: 10/14/2016

30160-10

OZ-POST

instant post holes

OZCO BUILDING PRODUCTS

Product & Packaging Specs

34" 4X4 Post Anchor (T4-850)

Item #: Typical Installation

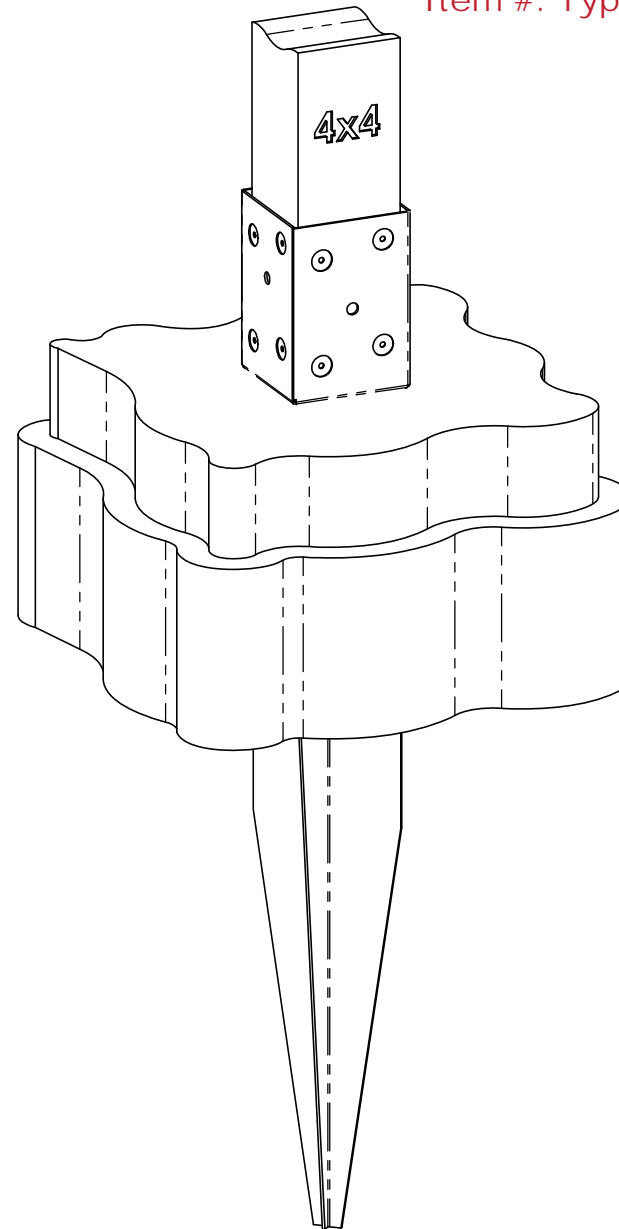
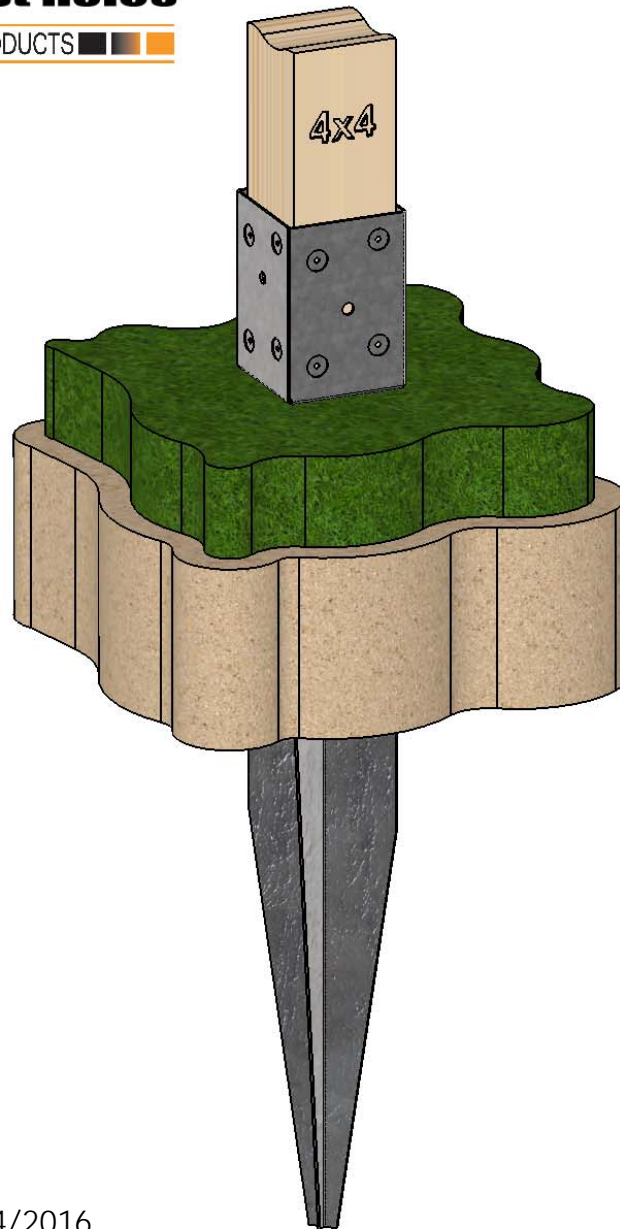

Weight: 7.24 LBS
Scale: 1:6
Last updated: 10/14/2016

30160-10

V2.00 - Installation Instructions, Specifications and Project Plans are effective 10/14/2016 . This information is updated periodically and should not be relied upon after 2 years from 10/14/2016 . Please visit OZCOBP.com to get current information. 4



instant post holes

OZCO BUILDING PRODUCTS ■■■

Product & Packaging Specs

34" 4X4 Post Anchor (T4-850)

Item #: 30160

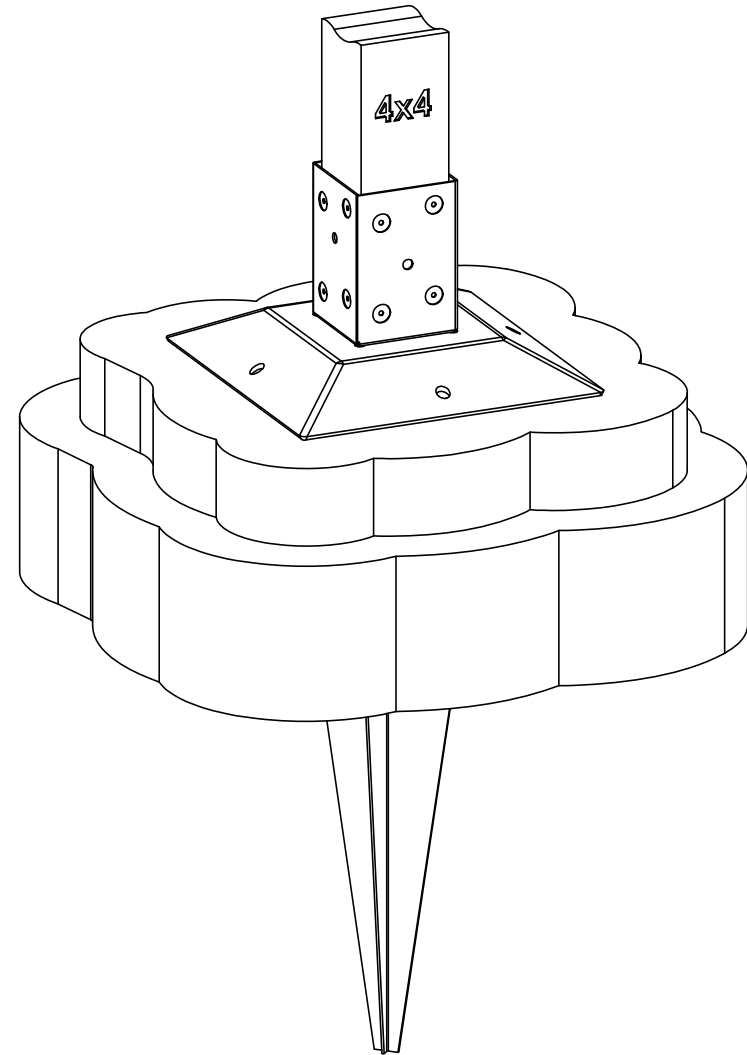
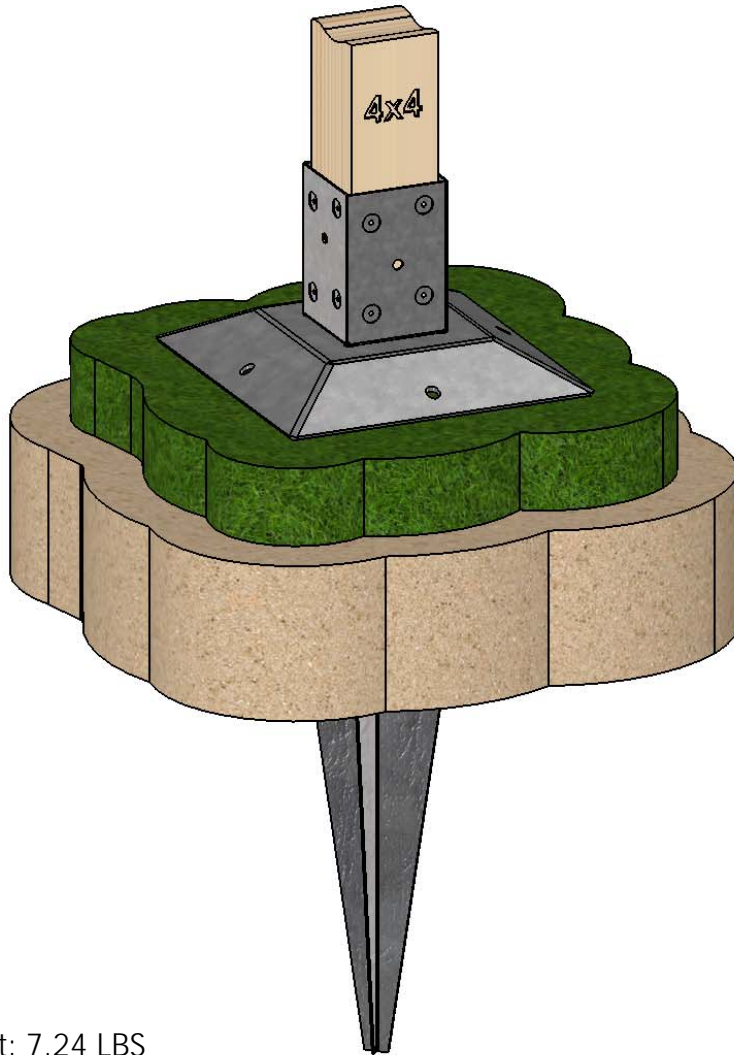

Weight: 7.24 LBS
Scale: 1:7
Last updated: 10/14/2016

30160-10

V2.00 - Installation Instructions, Specifications and Project Plans are effective 10/14/2016 . This information is updated periodically and should not be relied upon after 2 years from 10/14/2016 . Please visit OZCOBP.com to get current information.



Product & Packaging Specs

Case, 30160
Item #: Case, 30160

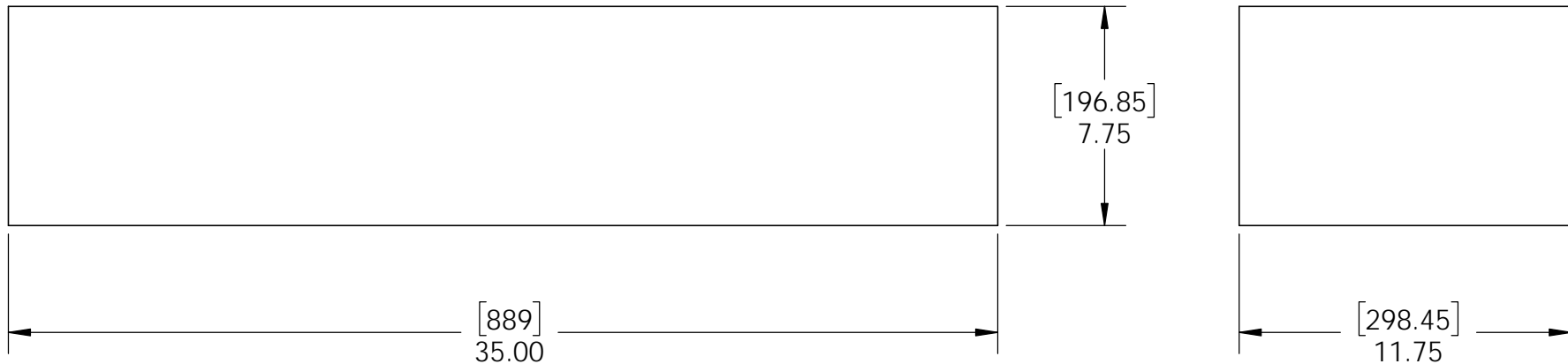
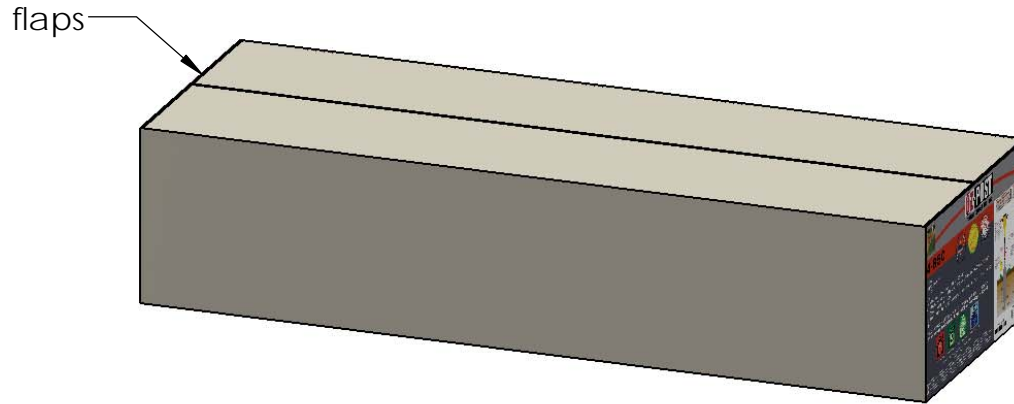

Material: Corrugated Paper
Finish: See Artwork
Weight: 0.69 LBS
Scale: 1:6
Last updated: 10/14/2016

30160-10



Product & Packaging Specs

30160 Packing
Item #: Case packing

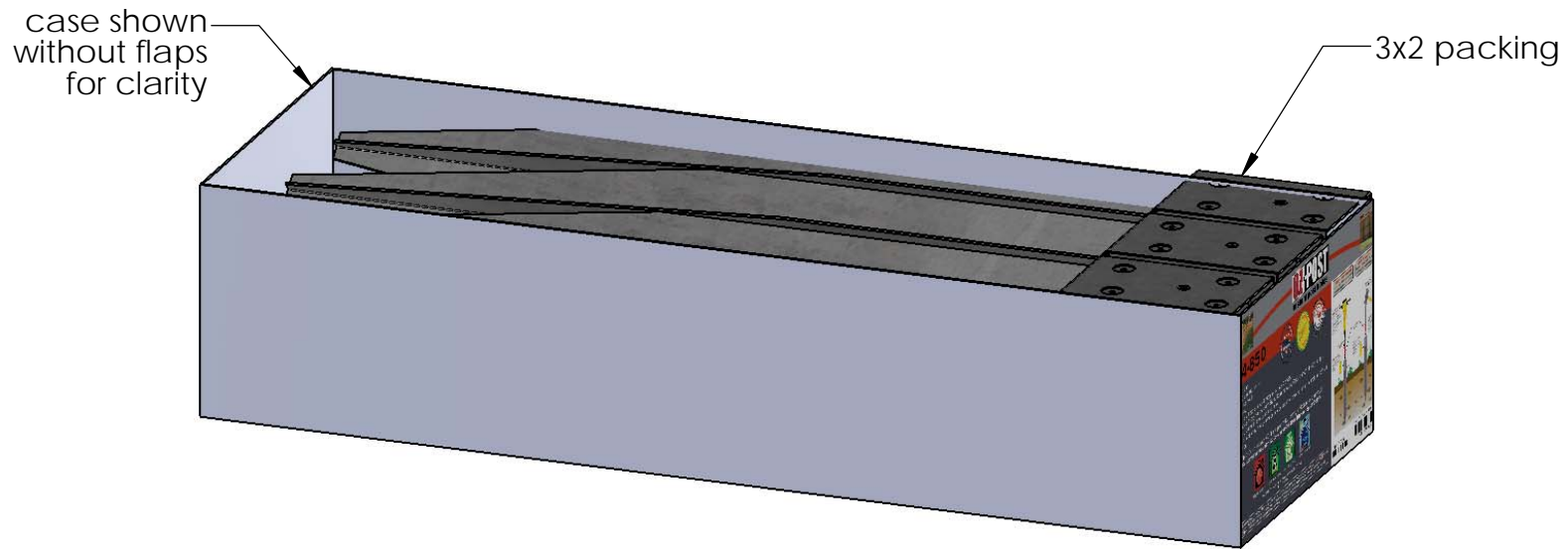

Weight: 43.93 LBS
Scale: 1:6
Last updated: 10/14/2016

30160-10



Product & Packaging Specs

30160 Packing
Item #: Pallet packing

Item #: **30160** | **T4-850**
T4-850 (3 1/2" Square) Wood
PALLET | **96 pcs**
SKU#: **30162** 
Weight: 776 lbs
LOT# _____ Priority# _____ 

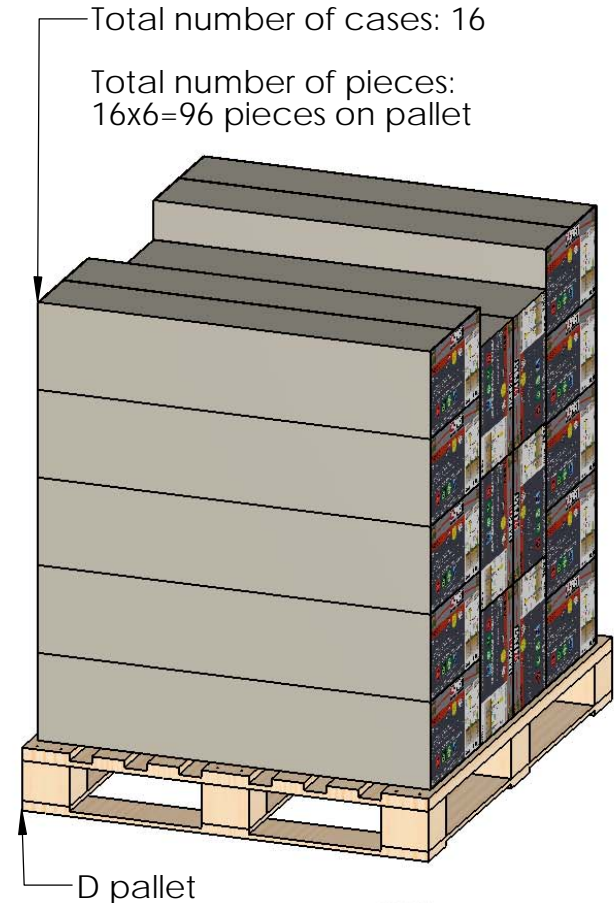
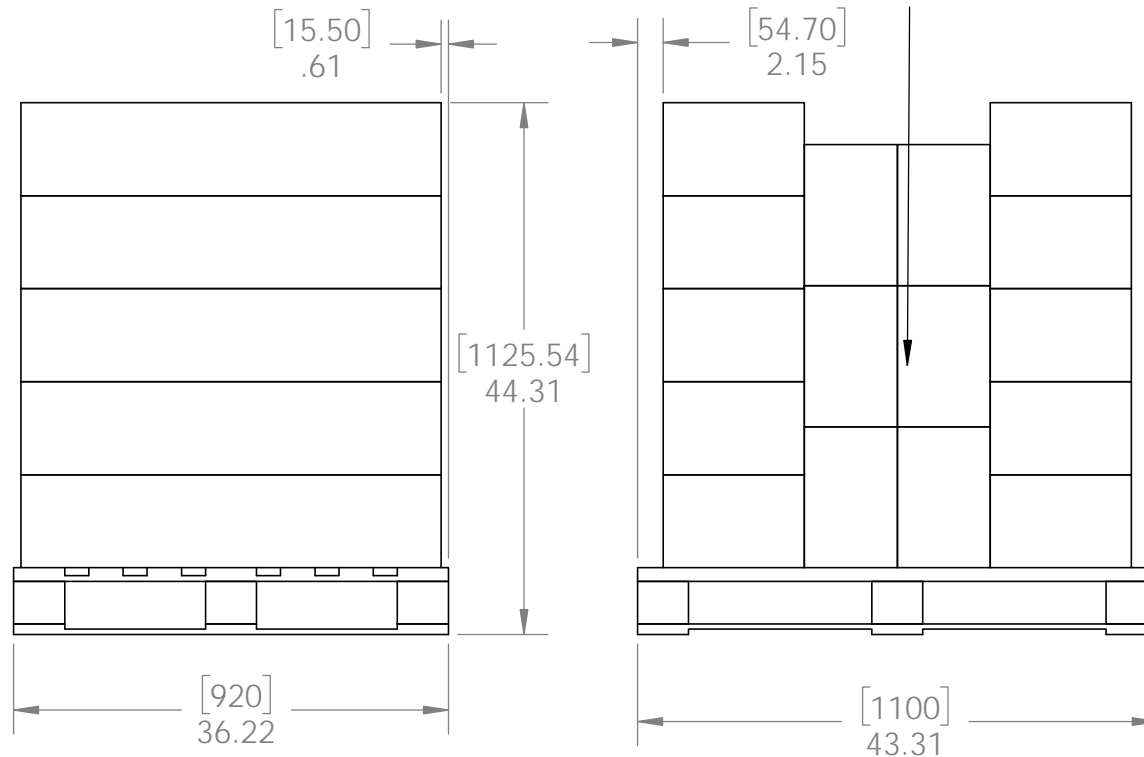

additional pallet packing instructions

- plywood on top layer
- strap to pallet
- clear wrap around boxes

Weight: 776 LBS
Scale: 1:16
Last updated: 10/14/2016

30160-10