

# OSF10 Fixture Mount Integral Luminaire Occupancy Sensor



OSF10 Front



OSF10 Back

## DESCRIPTION

Leviton's OSF10, Integral Occupancy Sensor, is designed to be mounted directly into a luminaire. The OSF10 offers a sensor and relay in one device. The wiring and housing of the sensor is installed adjacent to the ballast and hidden from view behind the reflector cover. Only the PIR detector dome lens and locking ring are visible on the exterior of the fixture.

## APPLICATIONS

Leviton's Integral Fixture Mount Occupancy Sensor is designed specifically for pre-wiring and installing inside of luminaire fixtures.

- Small offices
- Cubicles
- Task lighting
- Cabinet lighting
- Small bathroom lighting

## FEATURES AND BENEFITS

- Easy installation with longer 38" leads allows for easy connection to any ballast and eliminates the need to splice additional wiring
- Passive infrared detection technology for accurate sensing
- True Zero-Cross relay technology provides maximum contact life and compatibility with electronic ballasts
- Adjustable Time Delay located on sensor housing for easy access
- Aesthetically pleasing design
- Compact size for tight spaces
- 8' mounting heights for indoor use
- Internal fixture mount reduces number of devices on ceiling

## DIMENSIONS

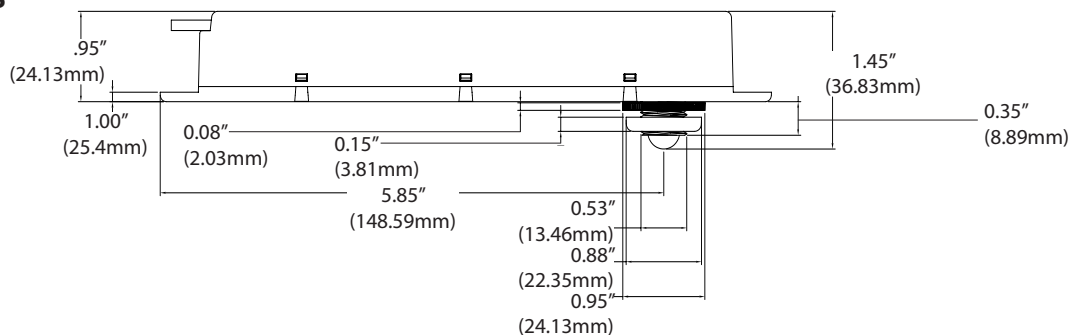

## OPERATION

The OSF10 utilizes passive infrared (PIR) technology with Auto-ON/Auto-OFF operation and an adjustable Time Delay to detect motion within its field of view. A small semiconductor heat detector resides behind a multi-zone optical lens, making the sensor sensitive to the heat emitted by occupants. This Fresnel lens establishes dozens of zones of detection. In order to initially trigger the sensor, the source of heat must move from one zone of detection to another. The OSF10 is most effective in sensing motion across its field-of-view.

Once the device senses motion, the sensor will automatically turn the lights ON. When motion is no longer detected, the sensor will conclude that the space is unoccupied. This will initiate the Delay Timer. If the delay timer expires and no motion is detected, the lights will turn OFF. If motion is detected, the delay timer will stop and the lights will remain ON.

## INSTALLATION

The OSF10 is designed to mount directly into a light fixture, with only the PIR lens being visible. The wiring and housing of the sensor is installed adjacent to the ballast, hidden from view behind the reflector's cover.

OSF10

**FEATURES**

- **Passive Infrared Technology (PIR):** The OSF10' uses Passive Infrared technology to detect motion.
- **Time Delay:** The time out occurs when motion is no longer detected by the sensor and the device counts a set amount of time before turning off the load. If the device sensor detects motion during this 'time delay' the count resets and the device initiates a new count. The Time Delay can be adjusted to 30 seconds, 10, 20, and 30 minutes respectively.

- **Zero-Crossing Circuitry:** Relay uses a zero-crossing circuitry to provide reliable, long-life operation.
- **LED:** A red LED blinks when motion is detected.
- **Fresnel Lens:** Detects small motion when mounted within 6' of occupants. When mounted at a height of 8', the coverage will be approximately 10' diameter but sensitivity may be diminished. The field-of-view below shows maximum coverage.

**SPECIFICATIONS**

<b>ELECTRICAL</b>	
<b>Input Voltage</b>	120-230-277
<b>Operational Frequency</b>	50/60Hz
<b>Wire Designation</b>	Line-Black, Load-Red, Neutral- White
<b>Load Rating</b>	Fluorescent Ballasts: 800VA @ 120VAC, 1200VA @ 277 VAC, Incandescent: 800W @ 120V, Motor: 1/6 HP Load @ 120V
<b>Time Delay</b>	30 Seconds, 10, 20 and 30 minutes
<b>ENVIRONMENTAL</b>	
<b>Operating Temperature Range</b>	32°F to 131°F (0° C to 55° C)
<b>Storage Temperature Range</b>	-50°F to 176°F (-10° C to 80° C)
<b>Relative Humidity</b>	20% to 90% non-condensing
<b>PHYSICAL</b>	
<b>Size</b>	7.50" (190.5mm)L x 0.90" (22.9mm)W x 1.00" x 1.00" (25.4mm)H
<b>Color</b>	White
<b>Lead Length</b>	38" (965.2mm)
<b>OTHER</b>	
<b>Listings</b>	Complies with FCC Regulations, NOM, CA Title 20/24 Compliant, UL Listed
<b>Warranty</b>	Limited Five-Year Warranty
<b>ORDERING INFORMATION</b>	
<b>OSF10-I0W</b>	120-277V Integral Luminaire Occupancy Sensor

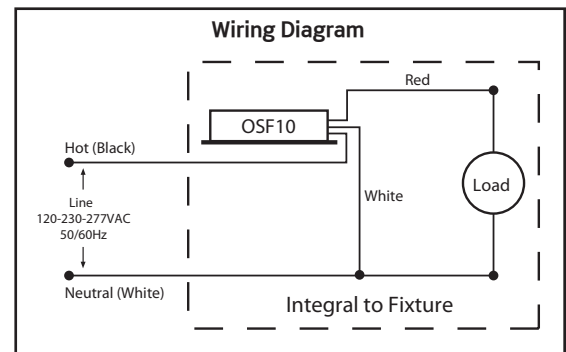
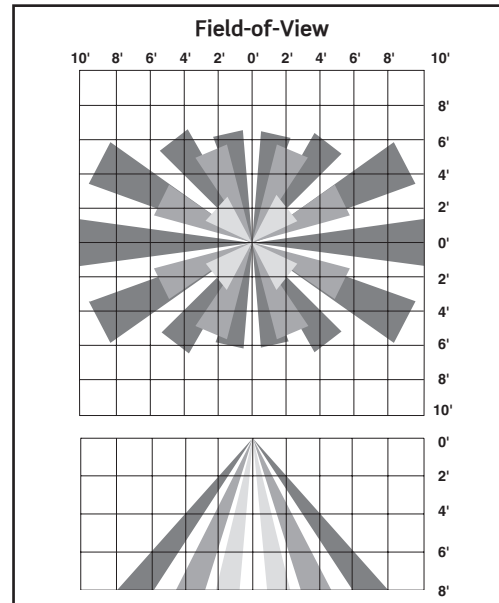

<b>LEVITON SPECIFICATION SUBMITTAL</b>	
JOB NAME:	CATALOG NUMBERS:
JOB NUMBER:	

**Leviton Manufacturing Co., Inc. Lighting & Energy Solutions**

20497 SW Teton Avenue, Tualatin, OR 97062  
 Telephone: 1-800-736-6682 • FAX: 503-404-5594 • Tech Line (6:00AM-4:00PM P.S.T. Monday-Friday): 1-800-959-6004

**Leviton Manufacturing of Canada, Ltd.**

165 Hymus Boulevard, Pointe Claire, Quebec H9R 1E9 • Telephone: 1-800-469-7890 • FAX: 1-800-563-1853

**Leviton S. de R.L. de C.V.**

Lago Tana 43, Mexico DF, Mexico CP 11290 • Tel. (+52) 55-5082-1040 • FAX: (+52) 5386-1797 • www.leviton.com.mx

Visit our Website at: [www.leviton.com/les](http://www.leviton.com/les)

© 2014 Leviton Manufacturing Co., Inc. All rights reserved. Subject to change without notice.