

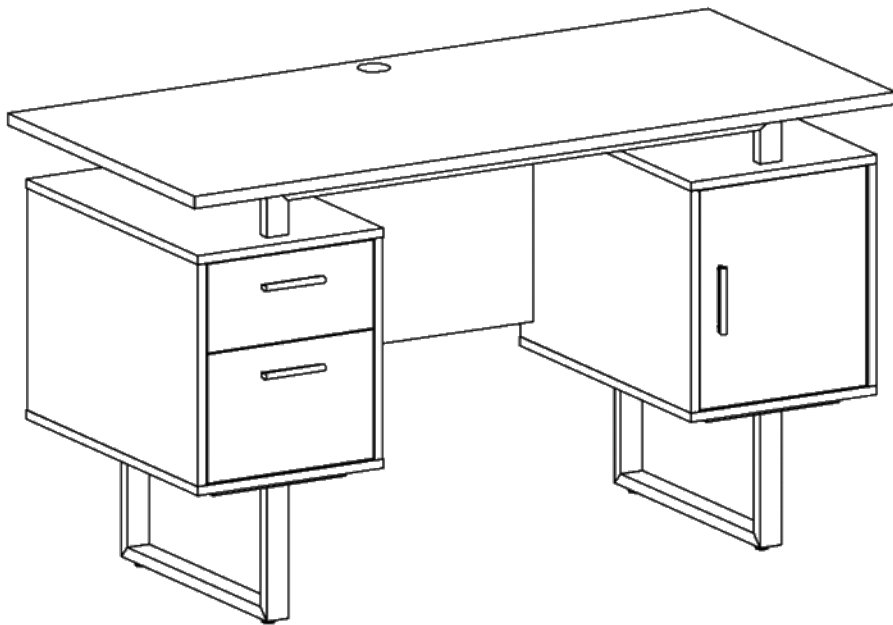

MODEL RTA-7002

ASSEMBLY INSTRUCTIONS

Thank you for purchasing our product.





- Please read carefully the assembly instructions before the installation.











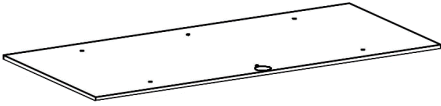

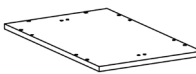
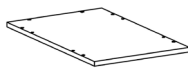
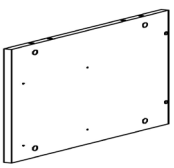
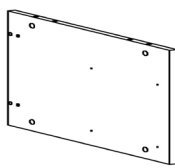
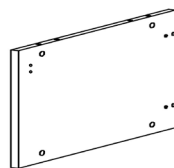
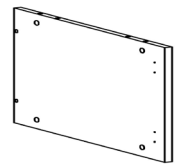
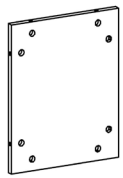
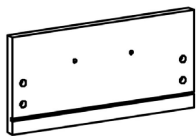
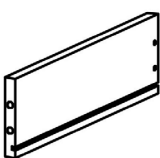
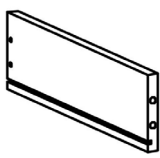

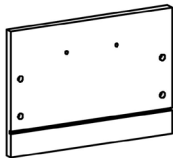
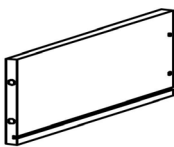

- Do not discard this manual or any of the packaging material until the unit has been completely assembled.

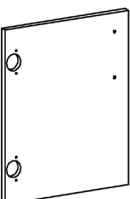
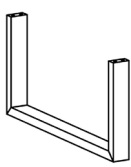



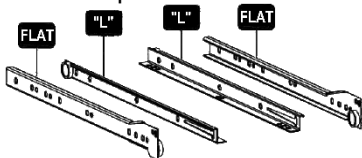
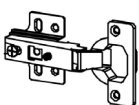





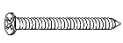
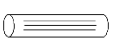

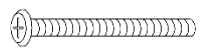
- Might require two people.

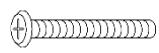
MAIN PARTS LIST

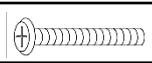
| | | | | |
|--|---|--|--|--|
| <p>1 x1</p> <p>Main panel</p>  | <p>2 x1</p> <p>Back panel</p>  | <p>3 x2</p> <p>Cabinet top panel</p>  | <p>4 x2</p> <p>Cabinet bottom panel</p>  | |
| <p>5 x1</p> <p>Left panel</p>  | <p>6 x1</p> <p>Middle-left panel</p>  | <p>7 x1</p> <p>Middle-right panel</p>  | <p>8 x1</p> <p>Right panel</p>  | <p>9 x2</p> <p>Cabinet back panel</p>  |
| <p>10 x1</p> <p>Small drawer front panel</p>  | <p>11 x1</p> <p>Small drawer left panel</p>  | <p>12 x1</p> <p>Small drawer right panel</p>  | <p>13 x1</p> <p>Small drawer back panel</p>  | <p>14 x1</p> <p>Large drawer front panel</p>  |
| <p>15 x1</p> <p>Large drawer left panel</p>  | <p>16 x1</p> <p>Large drawer right panel</p>  | <p>17 x1</p> <p>Large drawer back panel</p>  | <p>18 x2</p> <p>Drawer bottom panel</p>  | <p>19 x1</p> <p>Door</p>  |
| <p>20 x2</p> <p>Metal legs</p>  | <p>21 x2</p> <p>Long support tube for main panel</p>  | <p>22 x4</p> <p>Support tube for cabinet</p>  | <p>23 x1</p> <p>Grommet</p>  | |
| <p>24 x1</p> <p>Sliders, SET of 4 pcs: - 2 "flat" for inside the cabinets. - 2 "L" shape for the drawers.</p>  | <p>25 x2</p> <p>Hinges</p>  | <p>26 x3</p> <p>Handles</p>  | <p>27 x4</p> <p>Studs</p>  | |

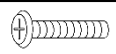
LIST OF HARDWARE, SCREWS AND FITTINGS

| PART | QTY | ITEM | | PART | QTY | ITEM | |
|------|---------|-----------------------|---|------|-----|-------------------|---|
| A | 40 sets | M6x35 Bolt + Cam lock |  | G | 8 | ST-3.5x40 |  |
| B | 16 | ∅8x30 |  | H | 6 | M4x22 |  |
| C | 4 | M6x50 |  | I | 12 | ST-3.5x14 |  |
| D | 6 | M6x40 |  | J | 18 | ST-3x14 |  |
| E | 16 | M6x35 |  | K | 1 | Bracket |  |
| F | 8 | M6x25 |  | L | 4 | Insert nut M6-∅10 |  |

NOTE: You will need for the assembly a Phillips screwdriver and mallet/hammer (not included).



MAIN PARTS LAYOUT (FOR REFERENCE):

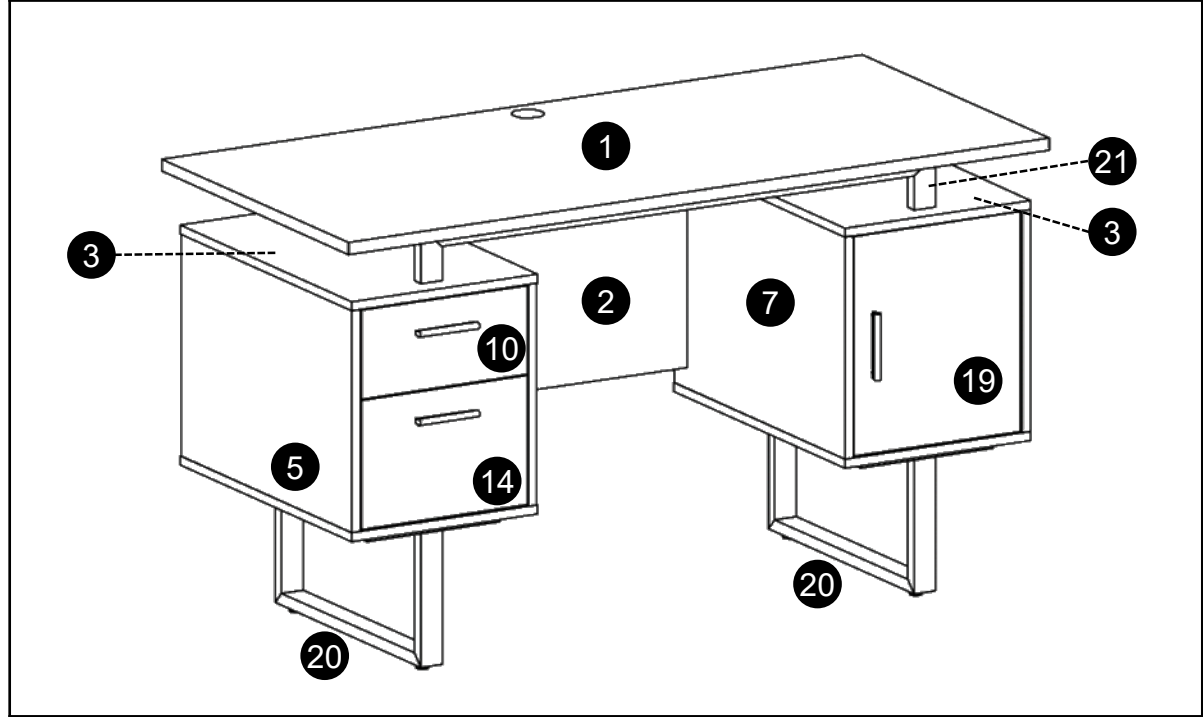

► This unit uses cam bolts and locks. The following explains how to use them. This is not an assembly step; it is a guide for when you are actually doing the assembly using this kind of hardware.

Cam Bolt



Cam Lock



1. Screw the bolt into the corresponding panel.

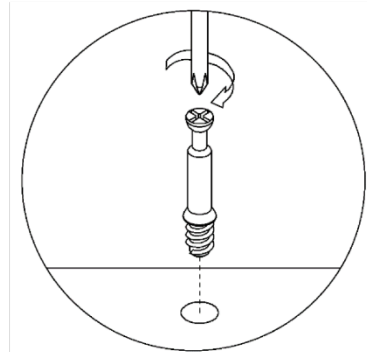
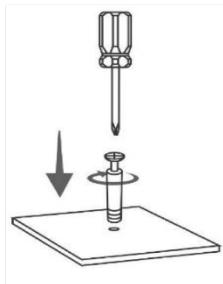

2. In the other panel, insert the cam lock and align it so it can properly receive the bolt, then join both panels. There might be a very small gap between the panels which is normal.

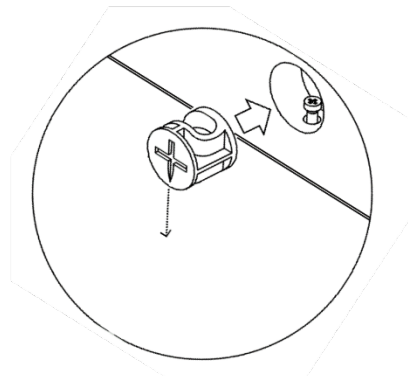
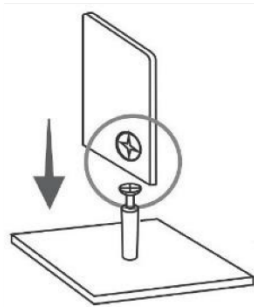

ALIGNMENT DIRECTION

3. Turn the cam lock clockwise to lock the parts together. If there was a small gap, it will also close.

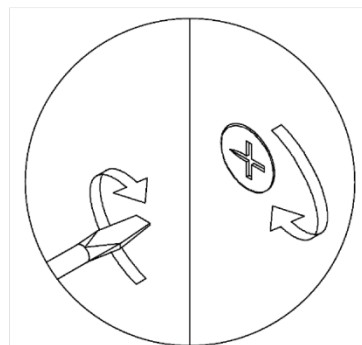
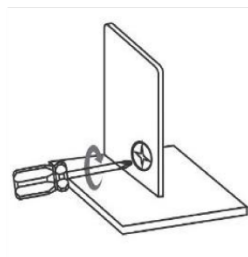

BEFORE YOU START THE ASSEMBLY, PLEASE READ THE FOLLOWING TIPS AND WARNINGS.

1 Do a quick inventory to make sure the package contains all the parts and hardware listed in the assembly instructions.



7 To avoid misalignments, always leave the screws loose and tighten them until all pieces are positioned correctly.

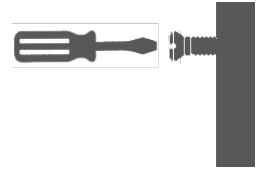

2 Missing, damaged and defective parts can be replaced at no cost to you. Please refer to the last pages on this manual.



8 Do not overtighten or force the screws as they might break, strip, damage the threads of the holes or get stuck inside the part.

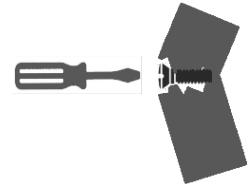

3 The replacement parts service is limited to the continental United States. If you reside in Hawaii, Puerto Rico, U.S. Dependencies or other countries, please contact the supplier from where the unit was purchased.



9 Sometimes the laminate might cover partially or entirely the hole on a panel. If there is no visible hole for the screw, pass and press the tip of your finger over the area where the hole should be located to feel the indentation, and once found, carefully pierce the laminate to reveal the hole underneath.



4 If during assembly you find an issue or need clarification, please contact our Customer Service for assistance. Please refer to the last pages on this manual.



5 On each step read the instructions and analyze the illustrations thoroughly before proceeding to do the assembly.



10 If the hole seems too small for the screw, first make sure you are using the correct size of screw and that it's been installed in the correct hole. If the hole still appears to be too small, carefully pierce the laminate to reveal the hole's actual size.

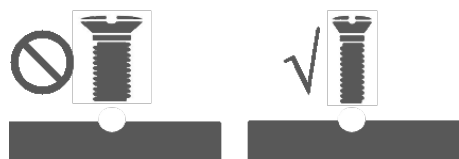

6 Make sure you understand which hardware will be used on each step. Using the wrong size of screw, bolt or pin might strip the threads or cause damage to the part in which it is being used.

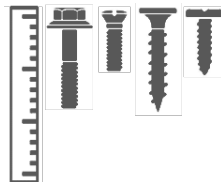

ASSEMBLY STEPS

STEP 1

Separate the sliders **24** according to their shape:

- The "L" sliders (for the drawers) will be used until step **16**, please set them aside.
- The "flat" sliders (for the cabinets) are the ones being used in step **2**.

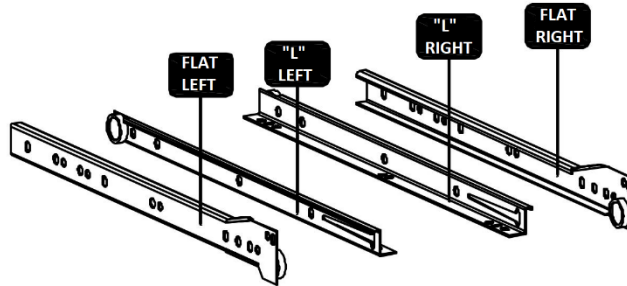

STEP 2

Hardware:

J



8 Pcs

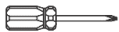

(NOT INCLUDED)



Scan QR Code to View this step

Assemble the flat sliders **24** to the panels **5** and **6** using screws **J** as shown. Note that the wheels face towards the front. Also pay attention to the correct hole for the screw.

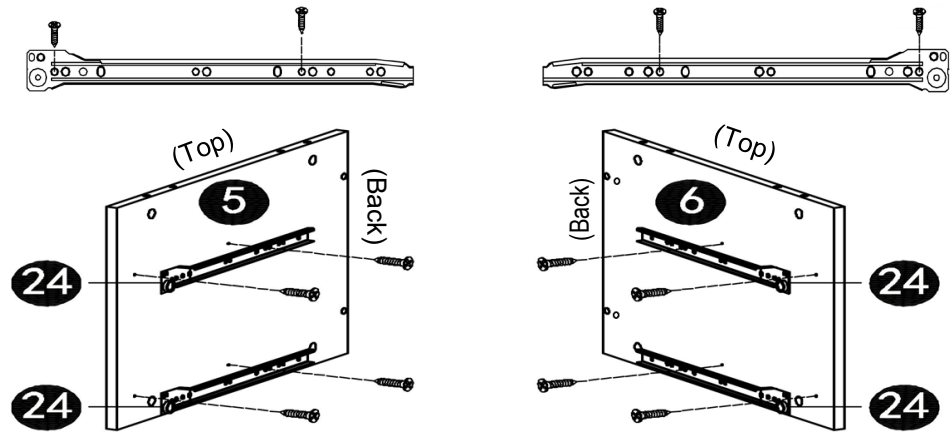

STEP 3

Hardware:

A



8 Pcs



(NOT INCLUDED)

Install the bolts **A** into panels **5**, **6**, **7** and **8** in the indicated holes.

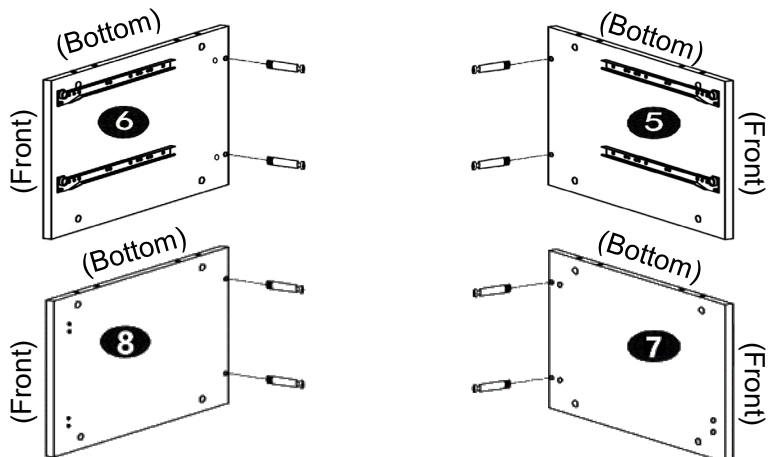

NOTE: For optimal assembly, work with all the panels upside-down oriented as shown.

STEP 4

Hardware:

A



Cam lock

8 Pcs

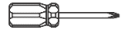

(NOT INCLUDED)

Install and align the cam locks **A** into the indicated holes on panels **9**, then assemble them to panels **5** and **6** for the drawers' cabinet, and to panels **7** and **8** for the storage cabinet as shown and as explained in page 5.

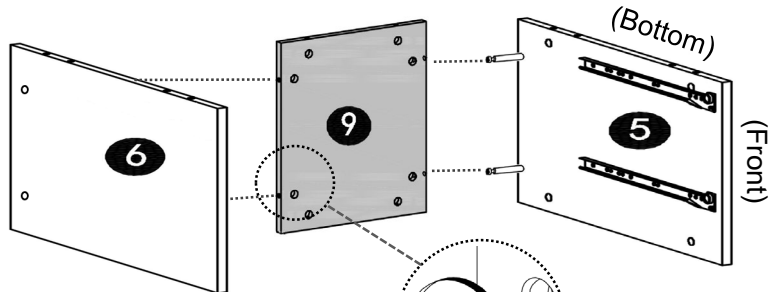
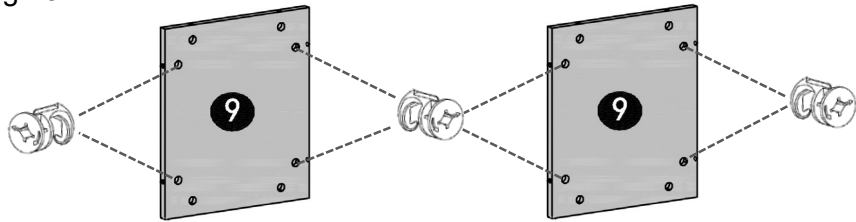

NOTE: For optimal assembly, work with all the panels upside-down oriented as shown.

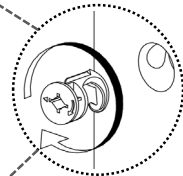

Don't forget to turn the cams afterwards to lock the panels.

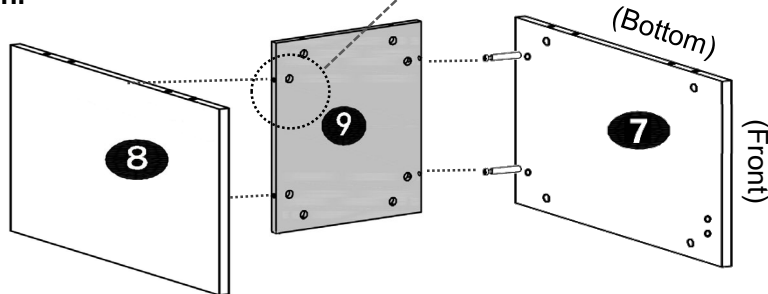

STEP 5

Hardware:

A



M6x35

24 Pcs

B



ø8x30

16 Pcs



(NOT INCLUDED)

Insert the bolts **A** and the wooden pins **B** into the corresponding holes on panels **3** (top panels) and **4** (bottom panels).

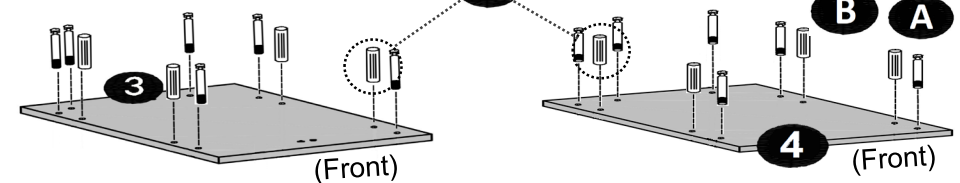
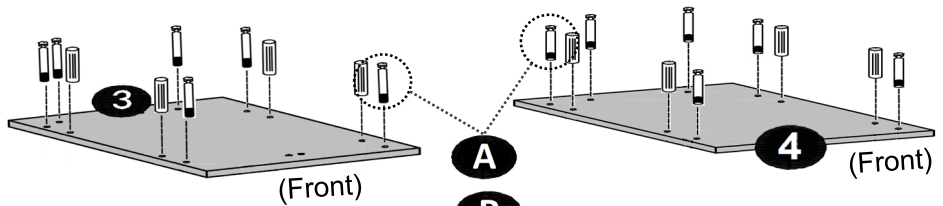

STEP 6

Hardware:

A



Cam lock

12 Pcs

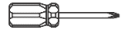

(NOT INCLUDED)

First insert and align the cam locks **A** into the corresponding holes on panels **5, 6, 7, 8** and **9**, then assemble the panels **4** to each cabinet as shown and as explained in page **5**.

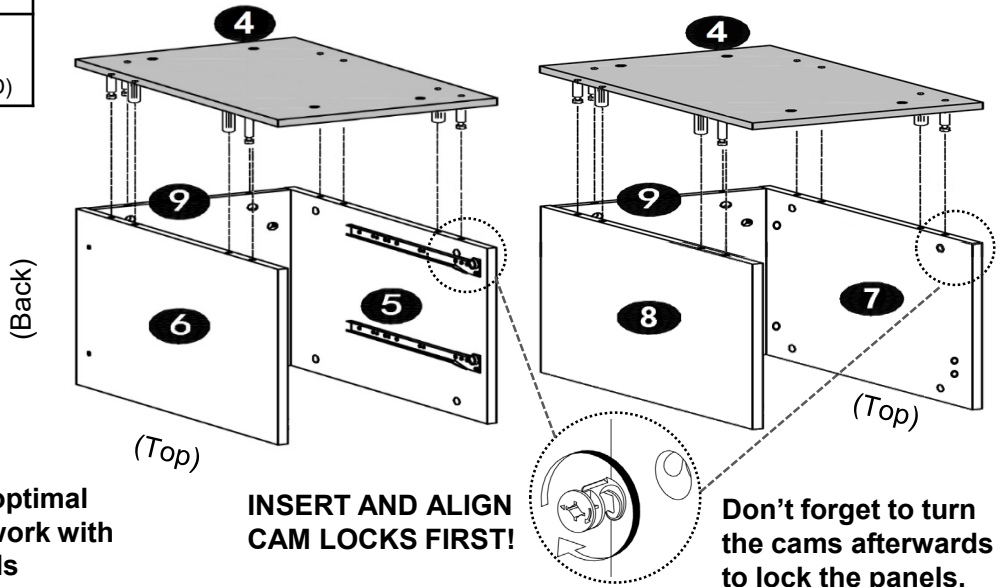

NOTE: For optimal assembly, work with all the panels upside-down oriented as shown.

INSERT AND ALIGN CAM LOCKS FIRST!

Don't forget to turn the cams afterwards to lock the panels.

STEP 7

Hardware:

E



M6x35

8 Pcs

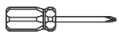

(NOT INCLUDED)

Assemble the support tubes **22** to the legs **20** using screws **E**, and insert the studs **27** on the bottom of the legs.

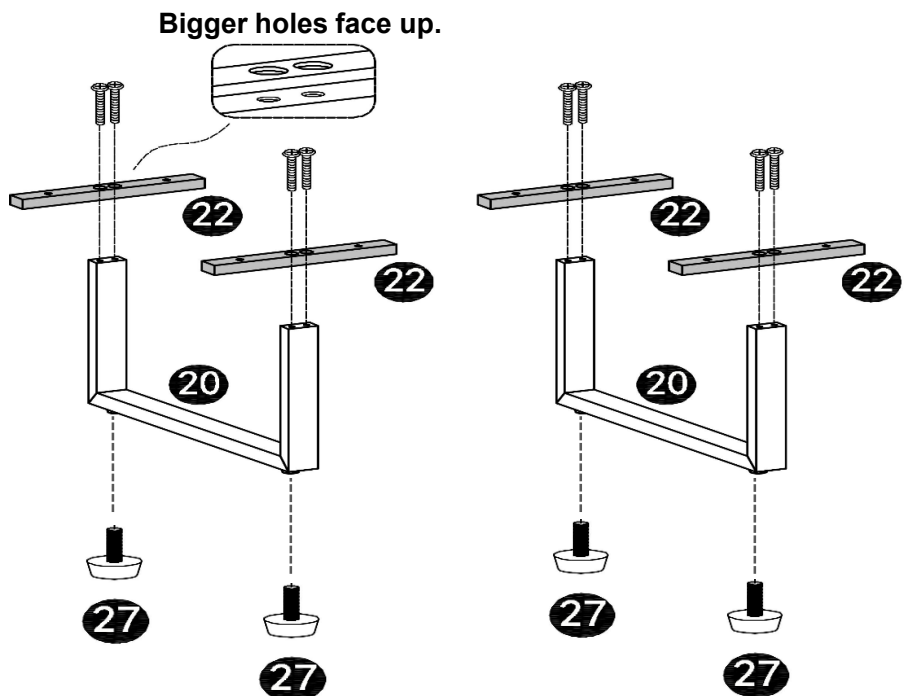

STEP 8

Hardware:

F



M6x25

8 Pcs



(NOT INCLUDED)

Assemble the bars **22** from each leg to each bottom panel **4** on both cabinets using screws **F** as shown.

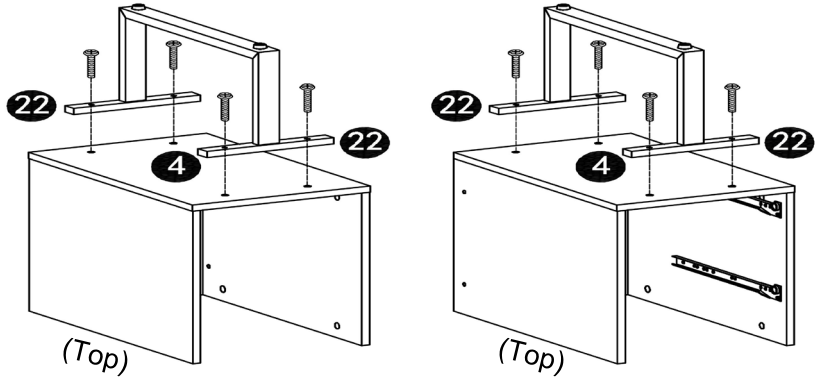

STEP 9

Hardware:

C



M6x50

4 Pcs

J



ST-3x14

2 Pcs

K



1 Pc

L



M6-ø10

4 Pcs

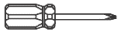

(NOT INCLUDED)



Scan QR Code to View this step

First insert the nuts **L** into the panel **2** and make sure they are aligned to receive the screws. Then, and with the help of another person, assemble both cabinets to panel **2** using screws **C**. Finally, assemble the metal bracket **K** to panel **7** using screws **J** as shown.
 Note: The bracket will function as a door stopper for panel **19**.

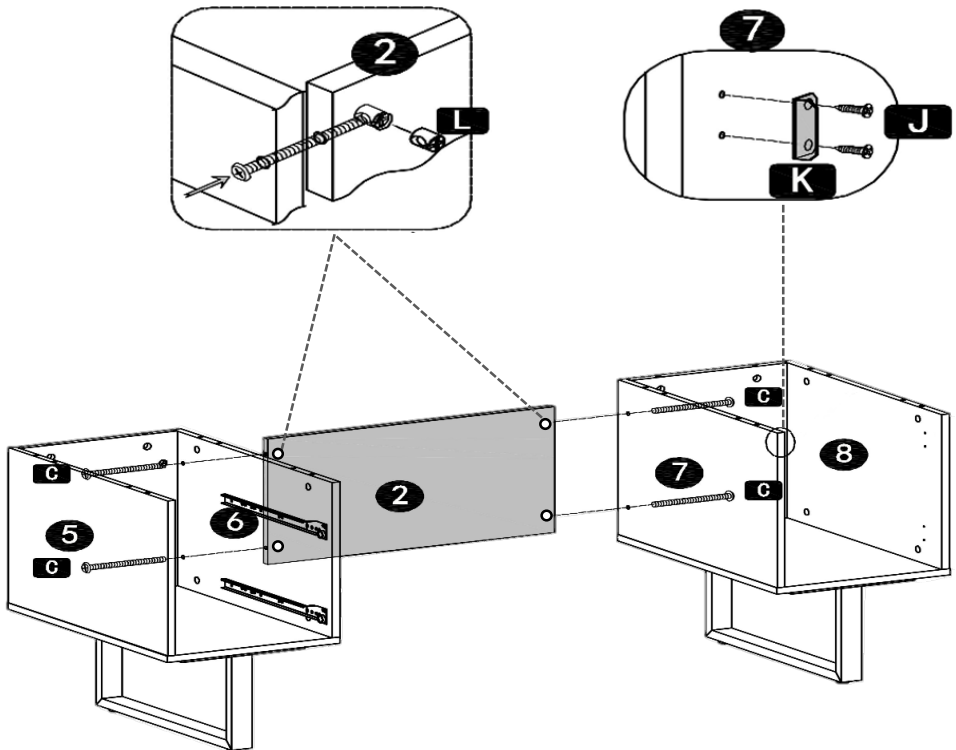

STEP 10

Hardware:

A  12 Pcs
Cam lock

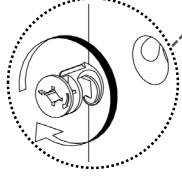

(NOT INCLUDED)

INSERT AND ALIGN CAM LOCKS FIRST!

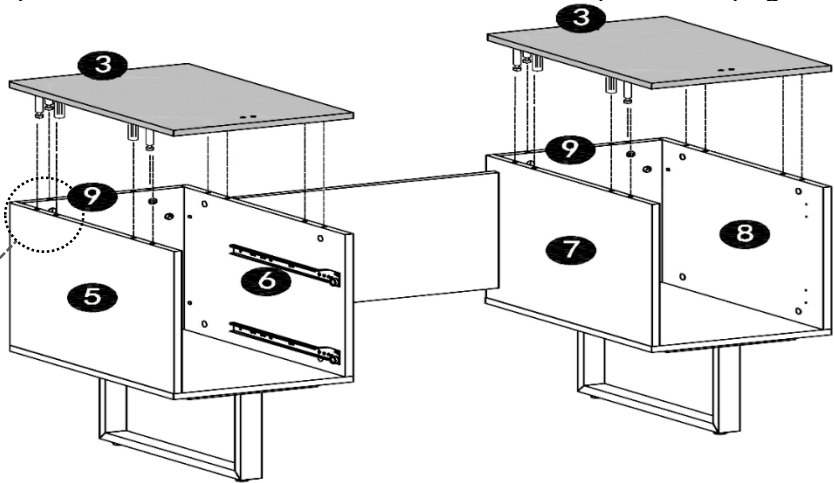

Don't forget to turn them afterwards to lock the panels.

First Insert the cam locks **A** into panels **5**, **6**, **7**, **8** and **9**, then assemble the top panels **3** to the structure as shown and as explained in page 5.



STEP 11

Hardware:

D  6 Pcs
M6x40

(NOT INCLUDED)

Carefully place the tabletop **1** upside-down over carpeting or a tablecloth to protect its finish, and assemble to it the long support tubes **21** using screws **D** as shown.

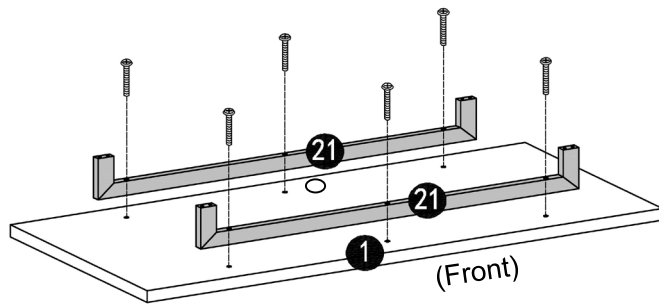

STEP 12

Hardware:

E  8 Pcs
M6x35

(NOT INCLUDED)



With the help of another person, place the tabletop over the structure and assemble the tubes **21** to the panels **3** using screws **E** from inside the cabinets as shown.

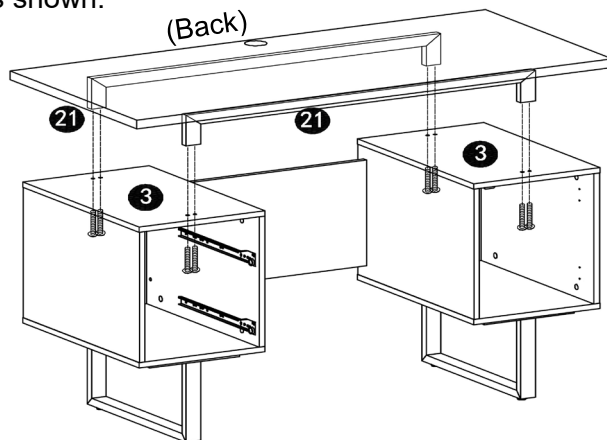

STEP 13

Hardware:

G



8 Pcs

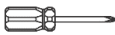

(NOT INCLUDED)

Using screws **G**, assemble the back panel **13** to panels **11** and **12** (for small drawer), and the panel **17** to panels **15** and **16** (for big drawer).

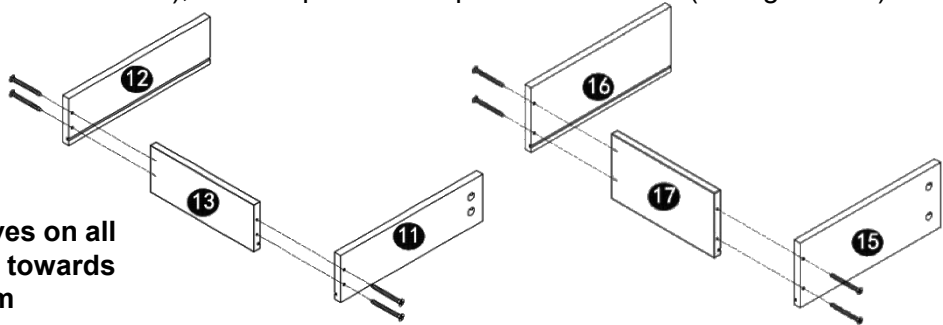

The grooves on all panels go towards the bottom

STEP 14

Slide the panels **18** through the grooves of all the panels assembled in step **13** for both drawers, as shown.

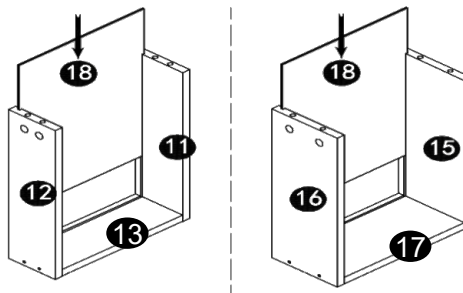

STEP 15

Hardware:

A



8 Sets

H



4 Pcs



(NOT INCLUDED)

First attach the bolts **A** to the panels **10** and **14**. Then install and align the cam locks **A** into panels **11**, **12**, **15** and **16**, and as explained in page **5**, assemble the front panels **10** and **14** to panels **11-12** and **14-15** respectively. Finally, install the handles **26** to the front panels using screws **H** as shown.

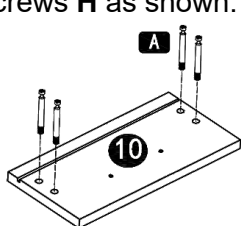

Don't forget to turn the cams afterwards to lock the panels.

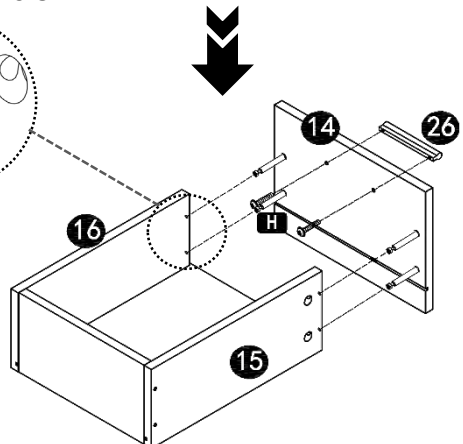
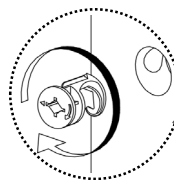
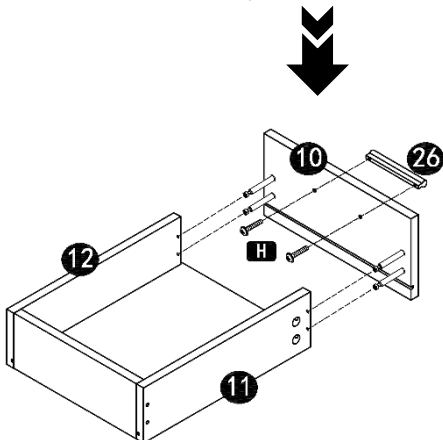
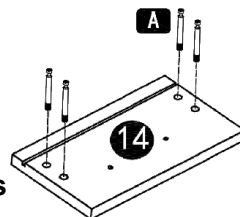

STEP 16

Hardware:

J

8
Pcs

(NOT INCLUDED)

Scan QR Code to
View this step

Assemble the “L” shape sliders **24** to the bottom of the drawers using screws **J**. Please note the orientation of the sliders: the rollers go towards the back, and the sliders should not protrude on the bottom, otherwise the drawers raise 3/4” and won’t fit in the unit.

ATTENTION: VERY IMPORTANT!

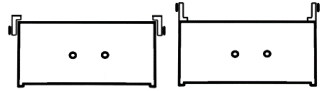

CORRECT INCORRECT

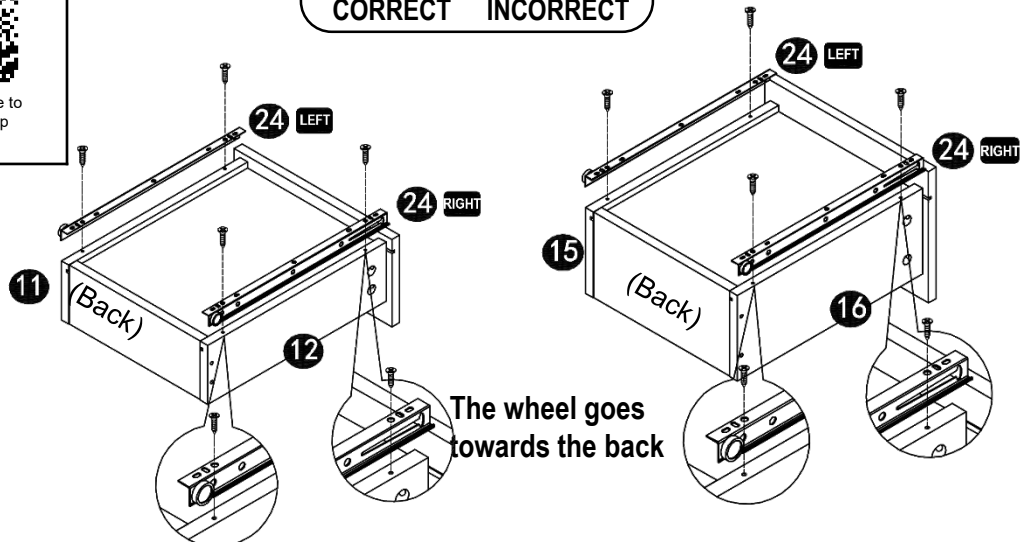

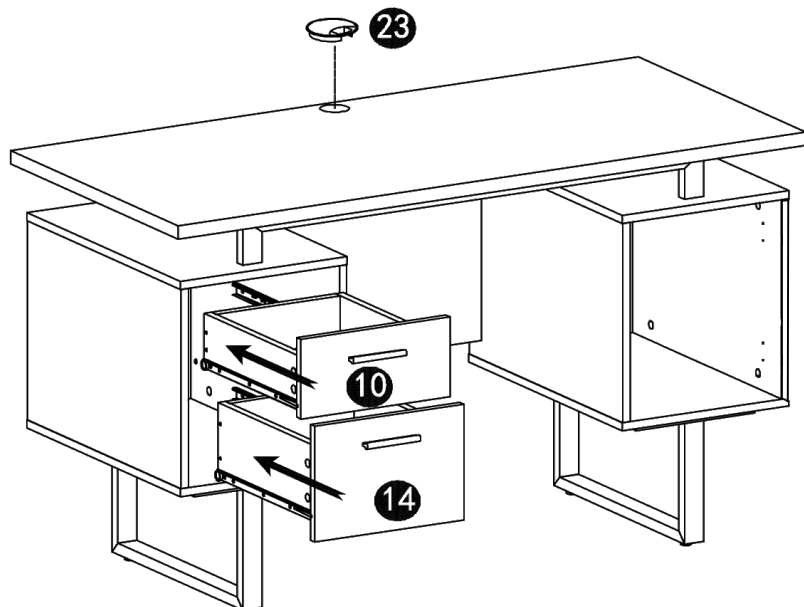

STEP 17

Insert the Grommet **23** into the hole of the tabletop **1**, then insert the drawers into the cabinet, the bottom drawer first, then the top drawer. The drawers might need to be inserted at an angle with their fronts facing down.



STEP 18

Hardware:

| | | |
|----------|---|-----|
| H |  | 2 |
| | M4x22 | Pcs |
| I |  | 4 |
| | ST-3.5x14 | Pcs |

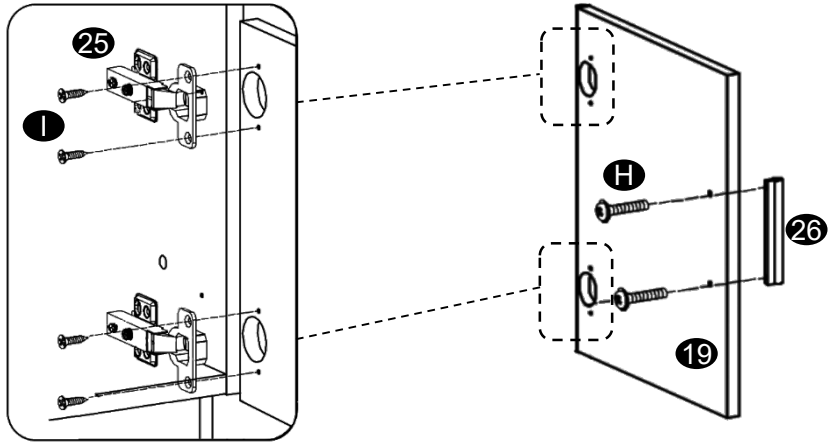

(NOT INCLUDED)

Assemble the handle **26** to the door **19** using screws **H**. Then assemble the hinges **25** using screws **I**.



STEP 19

Hardware:

| | | |
|----------|---|-----|
| I |  | 8 |
| | ST-3.5x14 | Pcs |

(NOT INCLUDED)

Assemble the hinges **25** from the door to panel **8** using 4 screws **I** on the OVAL holes only. Then fine-tune the hinges as instructed below, and when done, tighten the screws and fix the other 4 screws **I** on the round holes as shown.

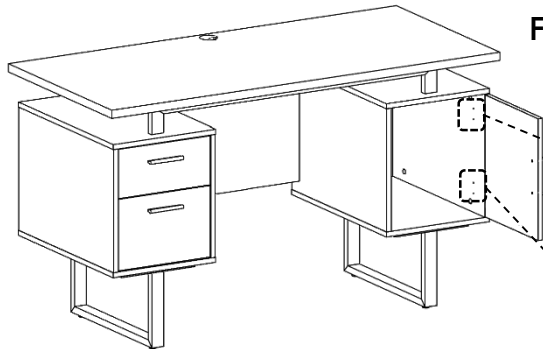

FIRST:

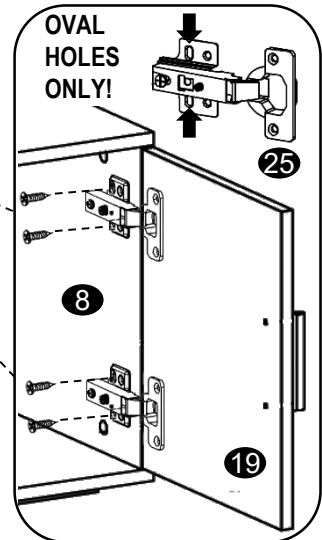

SECOND: ALIGN THE DOOR

A: This screw adjusts the depth.

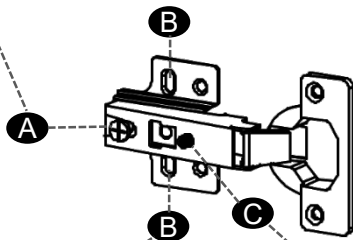

THIRD: SECURE

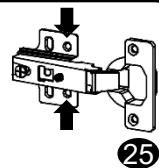

When the alignment is done, secure the hinges with screws on the round holes.

B: These screws adjust the height.

C: This screw adjust the alignment side-to-side.



ALL DONE!

Give yourself a nice pat on the back. You did a great job!

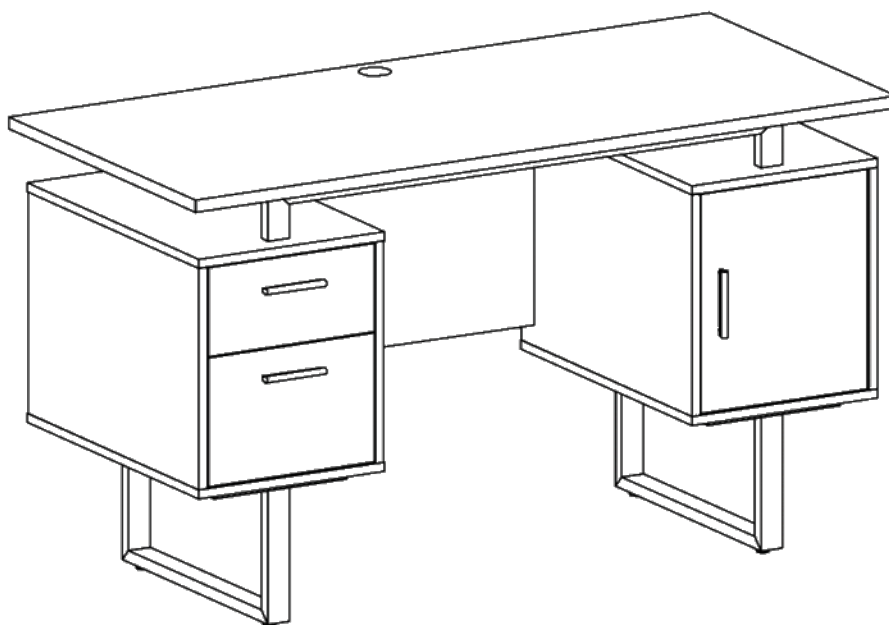

AFTER THE ASSEMBLY IS DONE, PLEASE READ CAREFULLY THE FOLLOWING CARE AND MAINTENANCE WARNINGS:

WEIGHT LIMITS

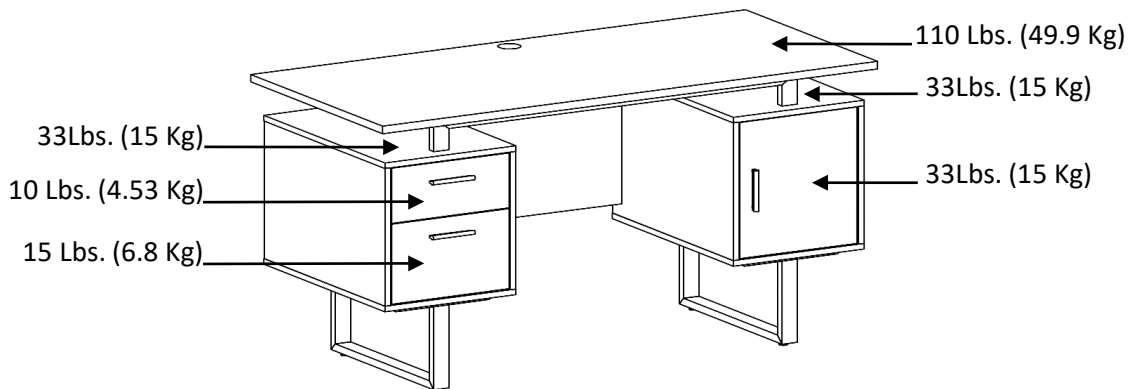

- Do not exceed the indicated weight limits.
- Do not expose the surfaces to direct sunlight or to extreme environmental conditions.
- Clean the surfaces preferable with a clean cloth damped in a solution of mild soap and water, then dry with a clean towel.
- Do not use solvents or abrasive materials to clean the unit.
- If you decide to use a cleaning agent, test first on an area hidden from view such as underneath the tabletop.
- Do not seat on the unit or lean against it.
- Do not allow small children to play under or over the unit.
- Do not allow small children to reach inside the drawers or storage without your supervision.
- Do not pull, push or drag the unit to move it for more than 1 feet. The unit must be lifted by at least 2 persons when moving in the same or adjacent rooms.
- Before moving the unit, make sure to secure or remove any object that is heavy or might fall off. Please note that lifting from the tabletop with too much weight on the product might lead to part damage/separation.
- When lifting the unit, use both hands and bend your knees, not your backs.
- When transporting the unit to places far away, protect and secure the unit to avoid damage in transit.
- Shall any part of the unit become defective during the warranty period, replacement parts might be available to you at no charge. Please refer to the last pages on this manual.
- The warranty does not extend to regular wear and tear, nor the manufacturer assumes liability for damages or consequences due to accidents, incorrect assembly, negligence, improper use, modifications, or not heeding the above warnings.

TECHNI MOBILI WARRANTY
DESKS/LAPTOP CARTS/FILE CABINETS: LIMITED 5-YEAR WARRANTY
TV Stand/Entertainment Center: 2 YEAR WARRANTY

RTA Products, LLC warrants to the Original Purchaser who acquired a new product from RTA Products or its authorized resellers that this product will be free from defects in its workmanship and materials, under normal use and service conditions, as described herein. "Defects" as used in this warranty, is defined as any imperfections that impair the use of the furniture or product. RTA Products LLC will replace any defective part, at its discretion, and without charge to the original purchaser other than the freight from the end consumer to RTA Products.

Replacement parts can only be supplied if parts are available. Items out of production may be unavailable. This warranty will be effective for the applicable time period beginning the date of purchase on your original sales receipt. RTA product's obligation under this warranty is limited to repairing or replacing products or parts as provided herein. This product has been designed for and is intended for office and home-office use only. This warranty is Original Purchaser's sole remedy for product defects, and this warranty does not extend to any product, or damage to any product, caused by or attributed to abuse or misuse, products used for commercial or rental purposes, use modifications of, or attachments to the product, and products or parts not used, maintained, or extended hereunder is in lieu of any and all other warranties, express or implied, including without limitations any implied warranty or merchantability or of fitness for a particular purpose. Please note, all desks made with PVC Laminate surface should not be exposed to direct sunlight, as it may damage the material. Damage of this nature is not covered under this warranty.

RTA Products will not be responsible for indirect, special, incidental or consequential damages. This warranty is limited to merchandise purchased in the Continental United States. Some States do not allow the exclusion or limitation of incidental or consequential damages, so the above limitations or exclusions may not apply to you. This warranty gives you specific legal rights. You may also have other rights that may vary from state to state.

RTA Products will advise you of the procedure to follow in making warranty claims. The following are the procedures for warranty claims:

- a. Call us Monday – Friday, from 9am-5pm (Eastern Time) at (866) 782-5520 to explain the defect and give your name, address and phone number. Please have ready the model number of our product, date and place of purchase. You can also write to us by e-mail to warranty@rtaproducts.com and include the same information.
- b. If we determine that replacement will remedy the situation, and in order to determine the extent or the cause of the defect, purchaser will need to send the part in question at purchaser's expense. Once we receive the part, we will examine it and determine whether the claim is valid (or not), and then proceed to send the replacement. We will ship the replacement at our expense.

FOR SEVERAL HELP OPTIONS INCLUDING REPLACEMENT PARTS ORDERS

VISIT: WWW.TECHNIMOBILI.COM



CLICK ON SUPPORT TAB



Scan QR Code to order replacement parts

OR EMAIL US: SUPPORT@RTAPRODUCTS.COM