



**Models 1500 & 1537G**

**OWNERS MANUAL**

**SOLID FUEL  
WARM AIR FURNACE**

\*FOR PARALLEL INSTALLATION WITH  
EXISTING FORCED AIR-GAS OR OIL  
FIRED FURNACE (U.S. ONLY)

\*FOR INSTALLATION AS A CENTRAL  
FURNACE

\*THE 1500 & 1537G HOTBLAST FUR-  
NACES HAS BEEN APPROVED FOR  
U.S. INSTALLATIONS ONLY.

\*CERTIFIED UNDER ANSI/UL 391 1983

**CAUTION:**  
READ ALL INSTRUCTIONS CARE-  
FULLY BEFORE STARTING THE  
INSTALLATION OR OPERATING  
THE FURNACE

**IMPROPER INSTALLATION MAY VOID  
YOUR WARRANTY**

**DO NOT USE THIS FURNACE  
IN A MOBILE HOME OR TRAILER**

**UNITED STATES STOVE COMPANY**

**227 Industrial Park Road**

**P.O.Box 151**

**South Pittsburg, TN 37380**

**(423) 837-2100**

**www.USSTOVE.com**



# CONGRATULATIONS!

You've purchased one of America's Finest Wood and Coal Burning Furnaces. By heating with wood and coal you're helping CONSERVE AMERICA'S ENERGY! Wood is our Renewable Energy Resource. Please do your part to preserve our wood supply. Plant at least one tree each year. Future generations will thank you.

**NOTE: YOUR UNIT MUST BE INSTALLED BY A QUALIFIED FURNACE INSTALLER.**

## TOOLS AND MATERIALS NEEDED

### TOOLS

Pencil  
6 Foot Folding Rule or Tape  
Tin Snips  
Drill, Hand or Electric  
Drill Bit- 1/8" Dia.  
(For Sheet Metal Screws)  
Screw Driver (Blade-Type)  
Gloves  
Sabre Saw  
5/16" Nut Driver or  
5/16" Socket w/Ratchet

### MATERIAL

6" Pipe, 6" Elbow, Collar and Thimble;  
as required (24 gauge min.)  
1/2" Sheet Metal Screws  
6" Inside diameter Listed Residential  
Type or Building Heating Appliance  
Chimney or existing masonry chimney  
Electrical Wiring  
6" Draft Regulator  
1/2" Conduit (Conduit Connectors)  
Furnace Cement (Manufacturer  
Recommends: Rutland Black-Code 78  
or Equivalent)  
Plenum and Duct work as required.

# Caution Labels

Your Furnace has the following labels. Read and Obey all labels.

**DANGER: RISK OF FIRE OR EXPLOSION.**

**DO NOT** burn garbage, gasoline, drain oil, or other flammable liquids.

**WARNING: FIRE HAZARD.**

**DO NOT** operate with fire draft exceeding .06 inches w.c.

**DO NOT** operate with fuel loading or ash removal doors open.

**DO NOT** store fuels, paints, thinners, flammable liquids, or other highly volatile substances in the furnace room.

**CAUTION: HOT SURFACES**

**Keep children away.**

**Do not touch during operation.**

---

## **CAUTION!**

---

INSPECT FLUE PIPES, FLUE PIPE JOINTS AND FLUE PIPE SEALS REGULARLY TO ENSURE THAT SMOKE AND FLUE GASES ARE NOT DRAWN INTO, AND CIRCULATED BY, THE AIR CIRCULATION SYSTEM.

---

---

## **CAUTION!**

---

CLEANOUT OF THE HEAT EXCHANGER, FLUE PIPE, CHIMNEY, AND DRAFT INDUCER (IF USED), IS ESPECIALLY IMPORTANT AT THE END OF THE HEATING SEASON TO MINIMIZE CORROSION DURING THE SUMMER MONTHS, CAUSED BY ACCUMULATED ASH.

---

**SAFETY NOTICE:** If this heater is not properly installed, a house fire may result. For your safety, follow the installation directions. Contact local building or fire officials about restrictions and installation inspection requirements in your area.

## Rules for safe installation and operation

Read these rules and the instructions carefully. Failure to follow them will cause a hazard that could result in death, serious bodily injury, and/or property damage.

1. Check your local codes. The installation must comply with their rulings.
2. Do not install this furnace in a mobile home or trailer.
3. Always connect this furnace to a chimney and vent to the outside. Never vent to another room or inside a building.
4. Do not connect this furnace to an aluminum Type B gas vent. This is not safe and is prohibited by the National Fire Protection Association Code. This furnace requires a masonry or Listed Factory Built Chimney for residential type or Building Heating Appliance Chimney. Use a 6" diameter chimney or larger, that is high enough to give a good draft. (See page 7)
5. Be sure that if a masonry chimney is used, it is safely constructed and in good repair. Have the chimney inspected by the Fire Department or an inspector.
6. Inspect chimney connector and chimney before and frequently during the heating season for any deposit of creosote or soot which must be removed (See Chimney Maintenance, page 15).
7. Provide air for combustion into the room where the furnace is located. If the intake is not in the same room, air must have free access to the room.
8. **CAST IRON PARTS MUST BE "SEASONED" TO AVOID CRACKING, BUILD ONLY SMALL FIRES ON FIRST USE.**
9. To prevent injury, do not allow anyone to use this furnace who is unfamiliar with the correct operation of the furnace.
10. For further information on using your furnace safely, obtain a copy of the National Fire Protection Association (NFPA) publication "Chimneys, Fireplaces and Solid Fuel Burning Appliances" NFPA 211. The address of the NFPA is Batterymarch Park, Quincy, MA 02269.
11. Keep the ashpit section free of excess ashes. Do not allow ashes to stack higher than the sides of the ash pan.
12. **DISPOSAL OF ASHES-** Place ashes in a metal container with a tight fitting lid. Keep the closed container on a noncombustible floor or on the ground, well away from all combustible materials. Keep the ashes in the closed container until all cinders have thoroughly cooled. The ashes may be buried in the ground or picked up by a refuse collector.
13. **CAUTION-** The special paints used on your furnace may give off some smoke while they are curing during first few fires., Build small fires at first. The metal used in construction of the furnace and duct work has a light coating of oil. This could give off smoke and/or odor from registers when furnace is used for the first time. This should disappear after a short period of time. Once this burn-off has occurred, it should not reoccur.
14. **CARING FOR PAINTED PARTS-** This furnace has a painted outside jacket, which is durable, but it will not stand rough handling or abuse. When installing your furnace, use care in handling. Clean with soap and warm water when furnace is not hot. **DO NOT** use any acids or scouring soap, as these wear and dull the finish. **DISCOLORATION WILL OCCUR IF THE FURNACE IS OVERHEATED. FOLLOW OPERATING INSTRUCTIONS CAREFULLY.**

Your Furnace is designed to be installed in a parallel air flow arrangement with a gas or oil-fired forced air upflow-type central furnace, or it may be installed as a central furnace.

# HOW THE FURNACE FUNCTIONS

Your HOTBLAST Furnace is designed to be a supplemental or central heating source for your home. This Solid Fuel Furnace may be installed in conjunction with a properly operating central furnace that is listed or certified in accordance with nationally recognized safety standards and equipped with the required controls and other safety features and which has been installed in accordance with appropriate standards of the National Fire Protection Association with installation clearances specified in the furnace nameplate marking. The installation must be accomplished by a qualified agency (one who is engaged in, and is responsible for, or is thoroughly familiar with the installation and operation of the gas, oil, and solid fuel burning heating appliances, who is experienced in such work, familiar with all the requirements of the authority having jurisdiction.) The installation shall be in strict accordance with the manufacturer's installation instructions furnished with the solid fuel furnace.

The chimney connector of the furnace is to be installed to provide clearances to combustible material not less than specified in the individual classifications and marked on the furnace. The chimney connector must be connected to a chimney suitable for use with residential type or building heating appliances which burn solid fuel.

The Furnace is designed to operate in either parallel or series air flow arrangement with the central furnace or as a central furnace.

**CENTRAL FURNACE INSTALLATION:** As a central furnace, the unit functions independently of any other system. The blower will come on when the plenum temperature reaches the setting on the blower control.

## **PARALLEL INSTALLATION:**

(See Optional Wiring Diagram, Page 13, Fig. 13) The design is such that when the blower comes on, the blower on the central system also comes on. The blower will only come on when the temperature in the plenum has reached the setting on the blower control. This is to insure that there is sufficient warm air in the system to make it efficient for the unit to operate. When the central system thermostat calls for heat, the central system will operate by the burner igniting and the blower coming on. It is possible that both systems will operate simultaneously. It is recommended that for the most efficient use of your HOTBLAST Furnace, that it be fired as much as possible in order to reduce the demand on your existing central heating system. This unit has an optional forced draft kit that operates from a wall thermostat. When the temperature falls below the setting on the wall thermostat, the forced draft will come on (U.S. Stove Option 11/DIKL)

The warm air supply outlet of the HOTBLAST Furnace shall not be connected to the cold air return of the central furnace, because the possibility exists of components of the central furnace overheating and causing the central furnace to operate other than is intended.

## **SERIES INSTALLATION:**

This type of installation uses only the blowers of the existing central furnace. The solid fuel fan/limit control must also control the functions of the existing furnace. All electrical power must come from a single branch circuit (See Fig. 14).

# DIMENSIONS OF FURNACE

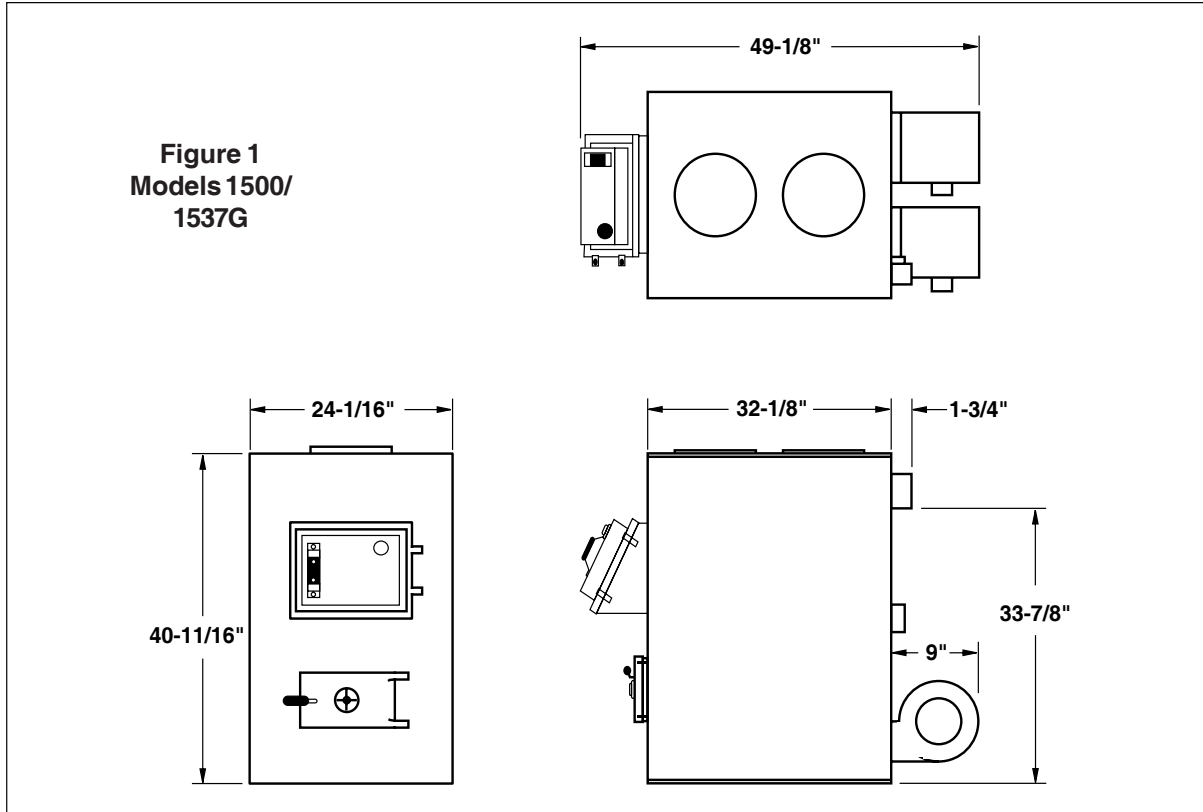

## CAUTION

GASES THAT ARE DRIVEN FROM FRESH COAL MUST BE BURNED OR THEY WILL ACCUMULATE AND EXPLODE. NEVER SMOTHER A FIRE WHEN ADDING FRESH COAL.

## CAUTION

NEVER USE GASOLINE, GASOLINE-TYPE LANTERN FUEL, KEROSENE, CHARCOAL LIGHTER FLUID, OR FLAMMABLE LIQUIDS TO START OR "FRESHEN UP" A FIRE IN THE FURNACE.

## CAUTION

DO NOT OPERATE WITH THE FEED AND/OR ASH DOOR OPEN. THIS FURNACE IS DESIGNED FOR THERMOSTATIC OPERATION. OPERATION WITH ANY OF THESE DOORS OPEN WILL OVERHEAT AND DAMAGE THE FURNACE.

## WARNING

NEVER STORE FLAMMABLE LIQUIDS, ESPECIALLY GASOLINE, IN THE VICINITY OF THE FURNACE.

## Locating the Furnace

1. The furnace should be located in the same room as the central system and as close as possible, but not closer than 9". There should be no wall between the furnace and the warm air outlet duct that is connected directly to the warm air outlet plenum of the central furnace. (See Fig. 2)
2. The unit will require installation with the following clearances:  
 Unit to sidewall.....12"(305mm)  
 Unit to backwall.....30"(760mm)  
 Chimney connector pipe to sidewall .....21"(530mm)  
 Chimney connector pipe to backwall .....18"(460mm)  
 Hot air ducts to combustibles .....6"(150mm)  
 (Refer to Fig. 2 & 3)

3. Place the furnace on a noncombustible floor.
4. Check figures 2 and 3. Be sure you have the clearances shown from the furnace and the connector pipe to combustible surfaces. If you have a solid brick or stone wall behind your furnace, you can place the furnace as close as you wish to the wall. If the wall is only faced with brick or stone, treat it as a combustible wall.

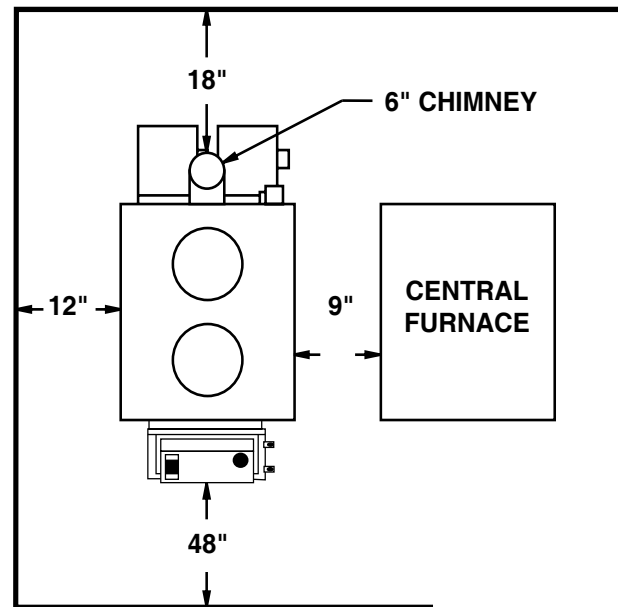

Figure 2

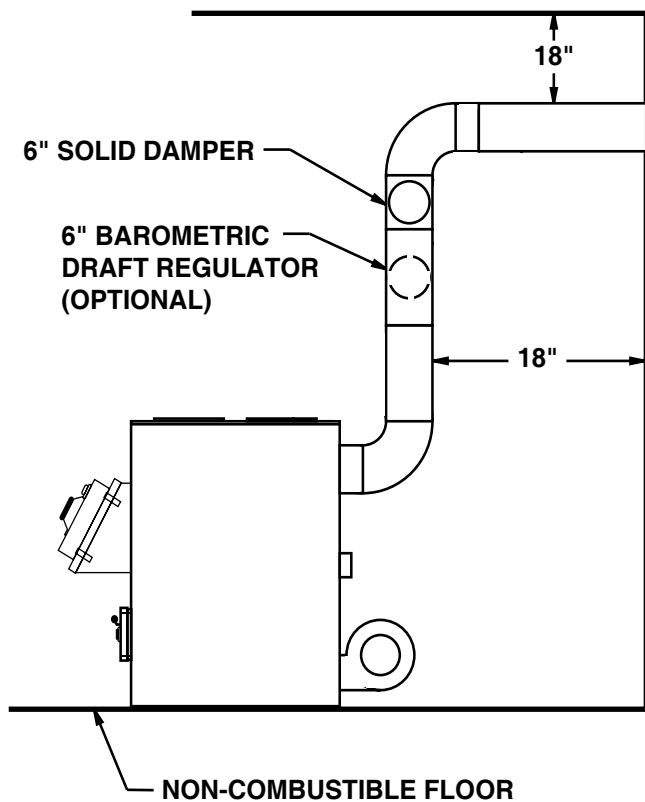

Figure 3

## Chimney Connection

### MASONRY CHIMNEY

Before using an existing masonry chimney, clean the chimney and inspect the flue liner to be sure it is safe to use. Make repairs before attaching the furnace. See page 4, item 5. Look at Fig. 4. The connector pipe and fittings you will need to connect directly to a masonry chimney are shown. The chimney connection should be as short as possible.

If the connector pipe must go through a combustible wall before entering the masonry chimney, consult a qualified mason or chimney dealer. The installation must conform to local fire codes, and N.F.P.A. 211.

**DO NOT CONNECT THIS FURNACE TO A CHIMNEY FLUE SERVING ANOTHER APPLIANCE.**

The chimney used for a furnace must not be used to ventilate the cellar or basement. If there is a cleanout opening at the base of the chimney, close it tightly.

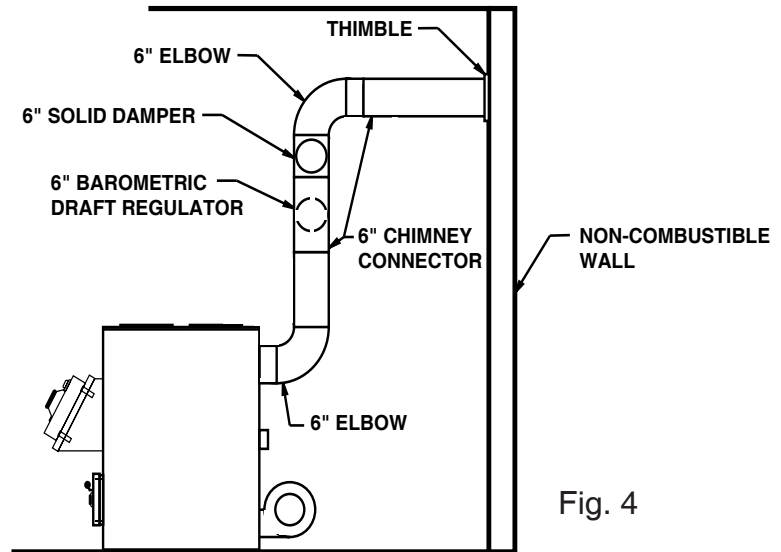

Fig. 4

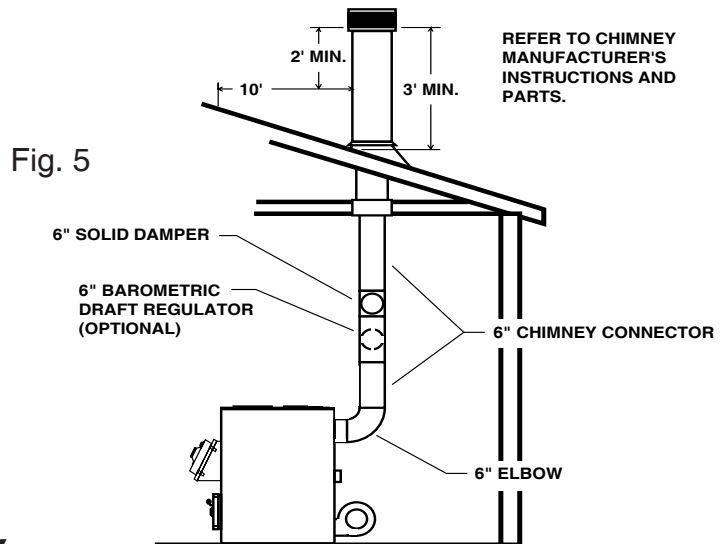

Fig. 5

### LISTED FACTORY BUILT CHIMNEY

Carefully follow chimney manufacturer's instructions. Use only a Listed Residential Type or Building Heating Appliance Chimney. If your chimney starts at the ceiling (Fig. 5), you will need enough 6" pipe to reach the ceiling.

The top of the chimney must be at least 3 feet above the roof and be at least 2 feet higher than any point of the roof within 10 feet (Fig. 5).



## Rules for Connector Pipe Installation

1. The crimped end of the chimney connector fits inside the furnace flue collar. Install additional chimney connectors and elbow with the **CRIMPED END TOWARD THE FURNACE**. This will allow any condensation in the flue to run back into the furnace. Use 6" dia. steel pipe and elbows for connection to chimney. Never use less than 24 gauge and although blued steel is satisfactory, high temp painted black is much more desirable.

2. Slope any horizontal pipe upward toward the chimney at least 1/4 inch for each foot of horizontal run.

3. You must have at least 18 inches of clearance between any horizontal piping and the ceiling. (See Fig. 3)

4. The chimney connector must not extend into the chimney flue. (See Fig. 6)

5. Seal each chimney connector pipe joint with furnace cement. Also seal the pipe at the chimney.

6. Use 3 sheet metal screws at each chimney pipe joint to make the piping rigid.

7. The chimney connector may include a section for a barometric draft regulator between the furnace and the chimney (Fig. 4,5, &7). The barometric draft regulator must be installed in the same room (same pressure zone) as the furnace.

8. Install the barometric draft regulator strictly in accordance with the instructions that are provided with the barometric draft regulator.

9. A solid damper must be used in the chimney connecting pipes between the flue collar and the chimney. When used in conjunction with a barometric draft regulator, the solid damper must be placed between the barometric and the chimney. (See Fig. 4,5,7)

### Adjusting the Barometric Draft Regulator

1. Drill a hole in the chimney connector within 18" of the flue collar below the barometric draft regulator just large enough for the tube of the manometer.

2. Build a fire after all chimney connections have been made.

3. Use a manometer to measure the draft in the flue.

4. Adjust the Barometric Draft Regulator to obtain a draft of 0.05 - 0.06" W.C. under stable fire conditions.

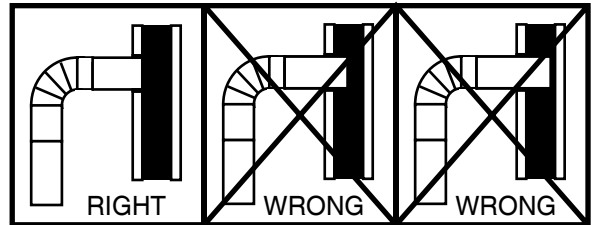

Fig. 6

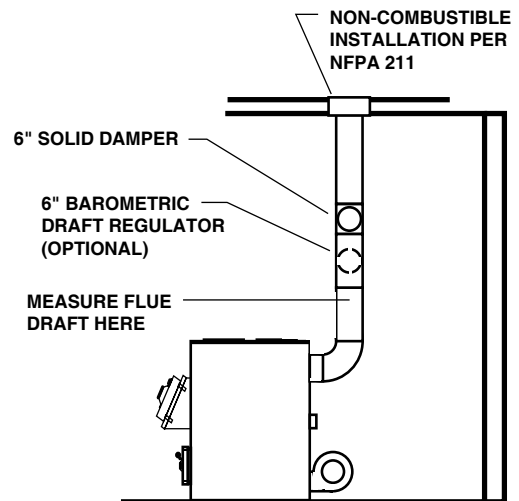

Fig. 7

## Assembly of Furnace

Your furnace requires the following items to be assembled or installed by the service person:

Feed Door Pull Handle  
 Feed Door Locking Handle  
 Blowers and Blower Controls  
 Electrical Connections

1. Remove all parts from inside the furnace and inspect for damage, including the firebrick as some breakage could occur during shipment.
2. Assemble the feed door pull handle as shown in Figure 8. Install thermostat assembly and cover (complete with handle) as illustrated in Figure 8.
3. Align thermostat control knob with flat on thermostat control shaft and press onto shaft. (See Fig. 8)
4. Attach feed door locking handle as in Figure 9 with screws and nuts provided. Note: Slotted holes are for adjustment of handle. Adjust handle until some pressure is required to lock feed door during firing sequence.
5. Install the thermodisc on rear of furnace cabinet with the two screws provided. Mount the conduit assembly from the junction box to the thermostat bracket. Crimp the two female terminals to each of the wire leads. Plug the wires to the thermodisc. *NOTE: It does not matter which of the two wires plugs to which terminal on the thermodisc.*
6. Remove blowers from cartons. Remove junction box cover. Attach clip nuts as in Figure 10. Install blower(s) and gasket(s) with 1/4"-20x3/4" bolts as shown.
7. Wire right side blower first (See wiring diagram, Fig. 11) and replace cover on junction box on blower.
8. Wire left blower same as above and replace cover.
9. Check operation of shaker grates with grate handle before operating furnace.

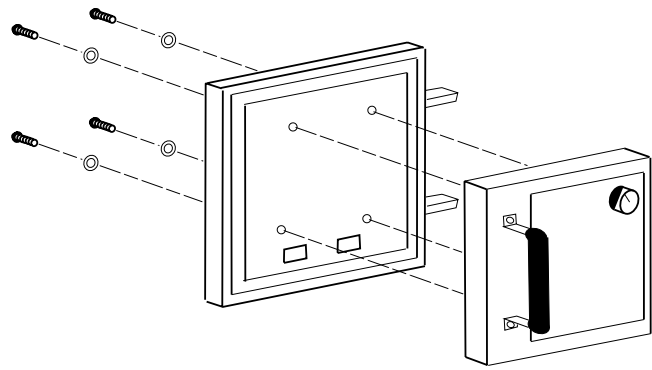

Fig. 8

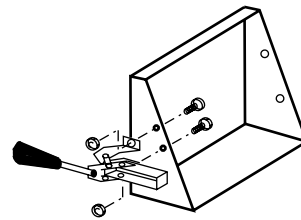

Fig. 9

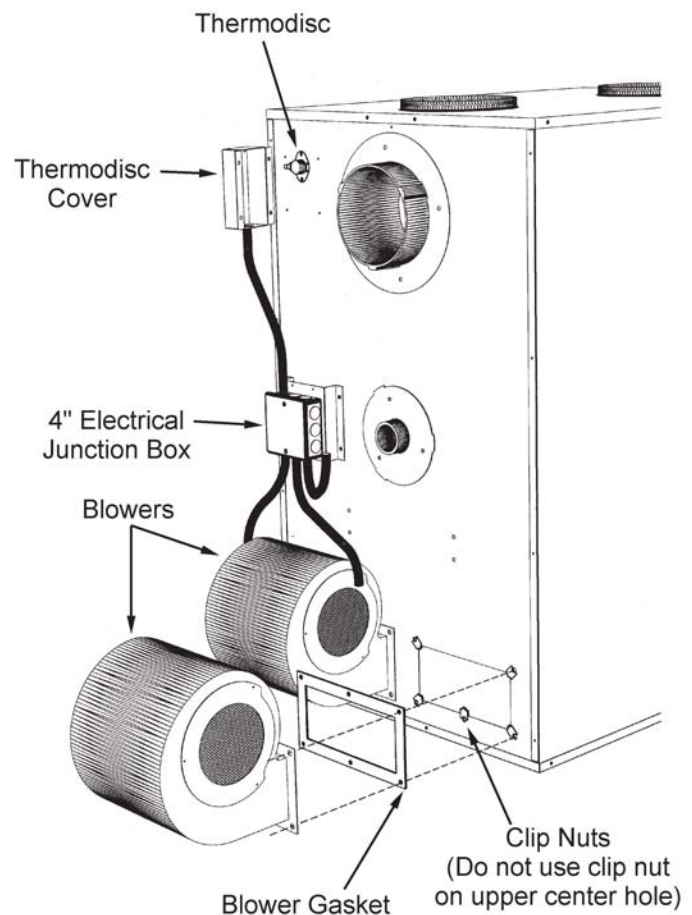

Fig. 10

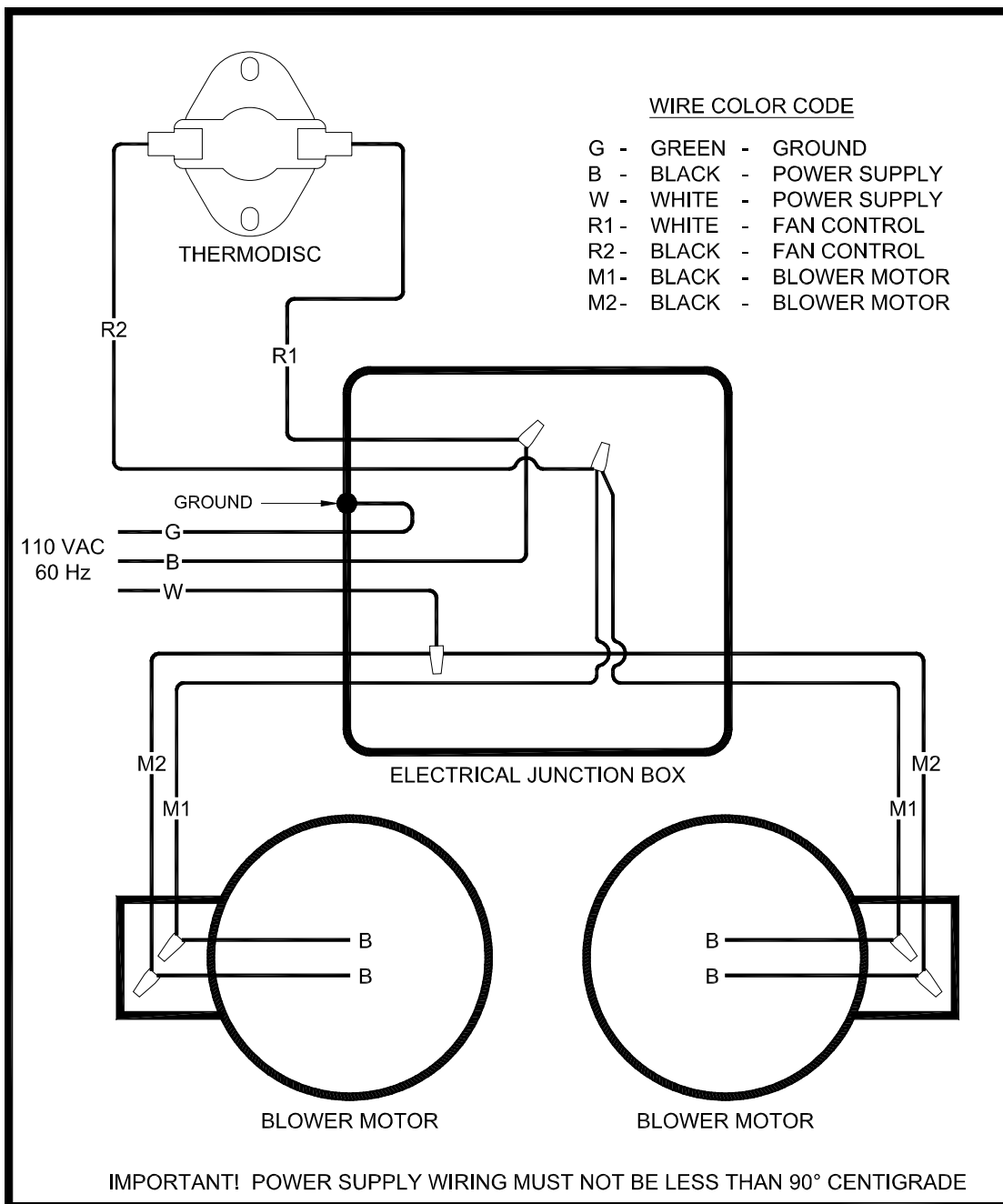

Fig. 11

**NOTE:**

Wire leads from the distribution blower are usually BOTH BLACK. Makes no difference which leads from the motors connects to the corresponding leads coming out of the conduit.

# Installation

**Please see all methods of Installation in Appendix at the rear of this booklet.**

This is a furnace, not a free standing stove. You must direct heated air from 8" outlets away from the furnace, or it will not function properly.

1. This installation must be done by a qualified heating equipment installer.
2. The installation is to be done in compliance with National Fire Protection Association installation standards: No. 89M, 90B, 211, 70 (National Electrical Code) and Uniform Mechanical Code 913, 6-4, in the states where applicable. (Their code offers connecting smoke pipe connectors into chimney with other fuel burning appliances.)
3. Rooms large in comparison with size of the appliance:
  - a) Wood or Coal Burning Furnace needs air for combustion and circulation to house.
  - b) Provision must be made to make up this air and not starve gas or oil furnace of combustion air.
  - c) Have "Authority Having Jurisdiction" determine that air is of adequate makeup. (Reference N.F.P.A. Nos. 30&54, Code for Installation of Gas & Oil Equipment).
4. Have "Authority Having Jurisdiction" is to inspect all chimneys and installations for adequate venting and for compliance with standard and local codes and regulations regarding installation of wood burning appliances.
5. Installation for Supplemental Heat Application to Existing Central System. (See Fig. 2 for typical installation.)
  - a) Place Wood or Coal Burning Furnace so that the chimney connector will be as short as practical and avoiding unnecessary sharp turns in the smoke pipe connector and the installation of devices that would create excessive resistance to the flow of flue gases.
  - b) Locate the Wood or Coal Burning Furnace as close as practical to the existing central hot air heating system, maintaining clearances as stated on the label on the fuel door.
  - c) Clearance from combustible materials must comply with those stated on the label on the fire door:  
Unit to combustible:  
Front: 48"  
Back: 30"  
Sides: 12"  
Plenum to Ceiling: 6"

Pipe to combustible:  
Sides: 21"  
Back: 18"

The installation must be made only on a noncombustible floor.

**d)** Install the smoke pipe connector to the chimney with 26-gauge pipe and elbows (to be purchased separately), maintaining the proper clearances for the specific model. Seal the smoke pipe in the chimney with furnace cement. (The chimney connector shall be securely supported, and joints fastened with sheet metal screws or rivets.)

**e)** Install 8" diameter heat pipe to plenum of the central hot air furnace. Use 26-gauge pipe and connectors (to be purchased separately). (See Fig. 15) If central air conditioning is installed in the plenum, install heat pipe above the air conditioning unit. Secure heat pipe connection with supports and sheet metal screws.

**f)** Connect electrical supply in the electrical junction box that is mounted on the back of the Furnace. See Wiring Diagram (Fig. 11). Remove the cover from electrical junction box and connect power supply wires to wires designated, using wire nuts. The power cord supplied may be used for installation, if permitted by local codes and regulations. If the power cord supplied cannot be used, the power supply wiring must be 90 degrees centigrade in a metal cable and should be completed by a qualified installer complying with NFPA Standard No. 70 and local codes.

## Power Failure Instructions

Operation after loss of power:

1. Remove filter if provided
2. Do not expect to keep home at normal temperatures.
3. Do not load fuel above bottom of feed door.

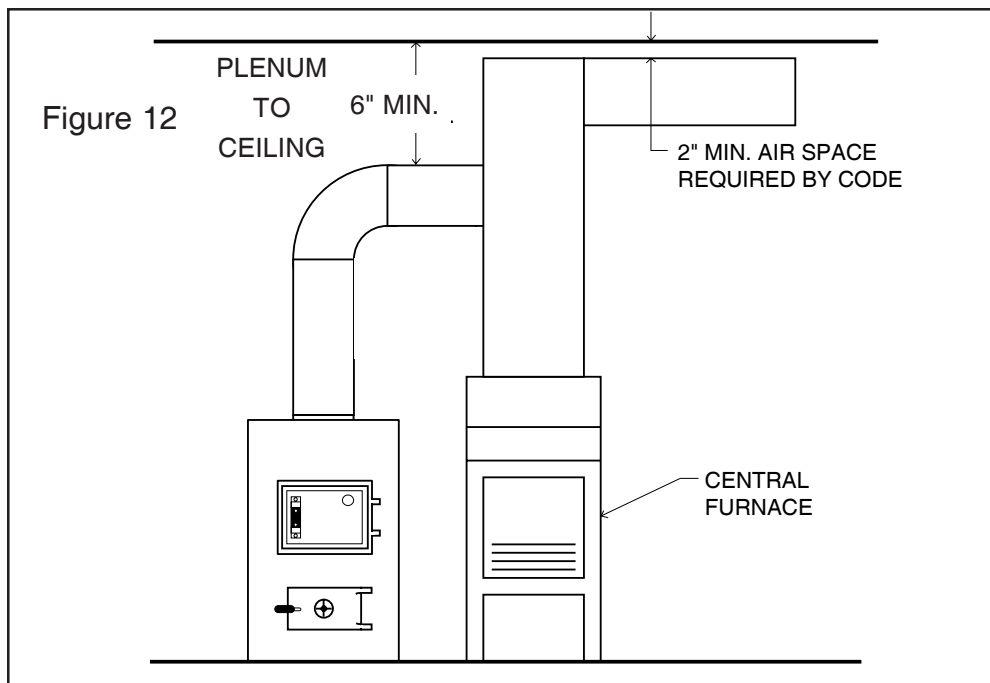

## Operating Instructions

### FUEL, Models 1500 & 1537G

Egg size (1-3/16" or larger) bituminous coal for residential furnaces, or any of the specially packed fireplace coals can be used. Coal with a low ash content (2% to 6%) is recommended.

Hardwood, 18" to 26" should be split and air dried (seasoned) for 6 months.

### LIGHTING

1. Set the thermostat on "HIGH" for maximum draft.
2. Open the feed door and place paper and kindling on the grate for starting the fire.
3. Light the fire and close the feed door.
4. Add wood or about 15 lbs. of coal (depending on which model) after fire is burning briskly. Set thermostat for desired temperature.
5. "MEDIUM" setting is normally satisfactory. Set higher or lower for your comfort.

### ADDING FUEL

When starting a fire, add small amounts of fuel instead of adding large quantities of fuel. This will give more complete combustion and less build-up of tars or soot in the chimney.

1. Set thermostat to HIGH before opening feed door.
2. Wood fire: Add wood to a convenient level.
3. Coal Fire:
  - a. Never smother the fire when adding coal (See Caution). Gas accumulation and a mild smoky explosion will occur. Add fresh kindling if the bed of coals has cooled.
  - b. Add up to 20 lbs. of coal per loading. Never add coal above the bottom of feed door opening.
  - c. Stir the coal and watch the fire. Be sure the new coal is burning briskly before you close the doors and turn the thermostat down.
  - d. Shake grates vigorously 1/2" left to right to spill ashes into the ash pan. Do this at least once every 12 hours of operation. Empty ash pan regularly. Do not allow ashes to build-up to grate as grate will warp and burnout, and you might spill the ashes when removing the pan. Dispose of hot ashes properly (See note 12 on page 4).
  - e. Rotation of the handle (5 o'clock to 7 o'clock) position will agitate coals and spill ashes into ash pan.
  - f. It is advisable for you to get familiar with the shaker grate operation before firing.

## Service Hints

Do not expect a furnace to draw. It is the chimney that creates the draft. Smoke spillage into the house or excessive build-up of water or creosote in the chimney are warnings that the chimney is not functioning properly. Correct the problem before using furnace. Possible causes are:

1. The connector pipe may be pushed into the chimney too far, stopping the draft (Fig. 6)
2. Do not connect two furnaces or a stove and furnace into the same chimney flue.
3. The chimney used for a furnace must not be used to ventilate the cellar or basement. If there is a cleanout opening at the base of the chimney, it must be closed tightly.
4. If the chimney is operating too cool, water will condense in the chimney and run back into the furnace. Creosote formation will be rapid and may block the chimney. Operate the furnace at a high enough fire to keep the chimney warm, preventing this condensation.
5. If the fire burns well, but sometimes smokes or burns slowly, it may be caused by the chimney top being lower than another part of the house or a nearby tree. The wind blowing over a house or a tree, falls on top of the chimney like water over a dam, beating down the smoke. The top of the chimney should be at least 3 feet above the roof and be at least 2 feet higher than any point of the roof within 10 feet (Fig. 5).
6. See page 24 for list of trouble shooting tips.

A draft reading of .05 to .06 w.c. is suggested for proper burning of this unit when using wood or bituminous coal as fuel. When using anthracite coal, this draft reading is a minimum reading.

## Chimney Maintenance

### Creosote and Soot - Formation and Need for Removal

When wood is burned slowly, it produces tar and other organic vapors, which combine with expelled moisture to form creosote. The creosote vapors condense in the relatively cool chimney flue of a slow-burning fire. As a result, creosote residue accumulates on the flue lining. When ignited, this creosote makes an extremely hot fire.

When coal is burned, the products of combustion combine with moisture to form a soot residue which accumulates on the flue lining. When ignited, this soot makes an extremely hot fire.

The chimney should be inspected at least twice monthly during the heating season to determine if a creosote or soot build up has occurred.

If creosote or soot has accumulated, it should be removed to reduce the risk of a chimney fire.

Chimney fires burn very hot. If the chimney catches fire, immediately call the fire department, then reduce the fire by closing the inlet air control. Pour a large quantity of coarse salt, baking soda or cool ashes on top of the fire in the firebox.

### **CAUTION**

**A chimney fire may cause ignition of wall studs or rafters which you thought were a safe distance from the chimney. If you have a chimney fire, have your chimney inspected by a qualified person before using again.**

# Model 1500 & 1537G Repair parts

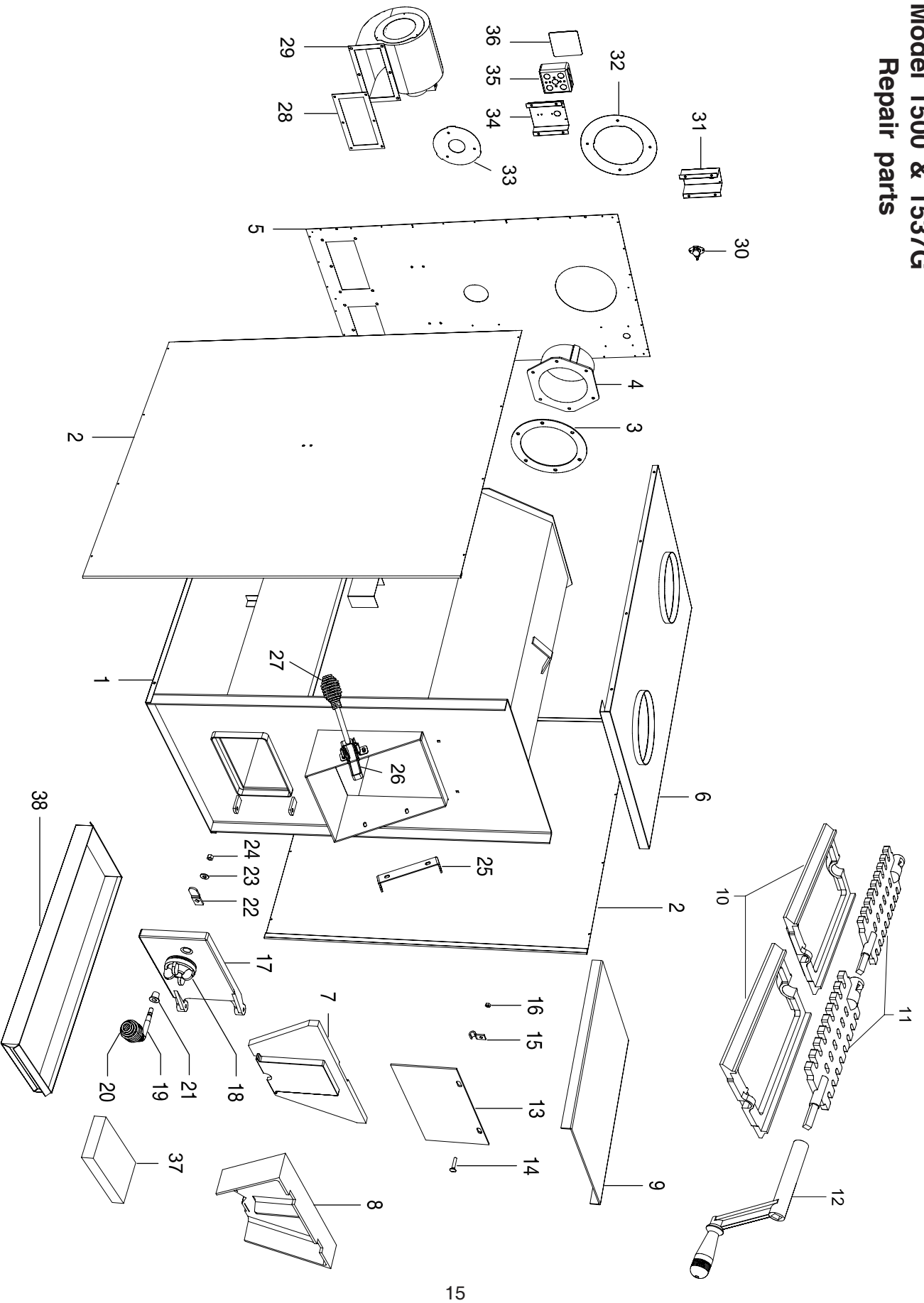

KEY	PART #	DESCRIPTION	QTY.
1	69509	Firebox Weldment	1
2	25467R	Cabinet Side (Left & Right) (Color - Red)	2
**	25467G	Cabinet Side (Left & Right) (Color - Green)	2
3	88032	Flue Collar Gasket	1
4	40246	Flue Collar	1
5	23459	Cabinet Back (Color - Red)	1
**	23459G	Cabinet Back (Color - Green)	1
6	25466R	Cabinet Top (Color - Red)	1
**	25466G	Cabinet Top (Color - Green)	1
7	40258	Rear Liner	1
8	40269	Front Liner	1
9	23398	Baffle	1
10	40256	Shaker Grate Frame	2
11	40257	Shaker Grate	2
12	40260	Shaker Handle	1
13	23800	Smoke Curtain	1
14	83445	1/4-20 x 1-1/4 Carriage Bolt	2
15	23787	Smoke Curtain Clip	2
16	83250	1/4-20 Kep Nut	2
17	68218	Ash Door Assembly (Includes Door and Gasket)	1
18	23859B	Draft Cap (Painted)	1
19	89354	Ash Door Handle	1
**	891098	Ash Door Handle	1
20**	89574	Spring Handle	1
21	*****	Handle Bushing (Included with Handle)	1
22	23445	Door Latch	1
23	83461	Handle Washer	1
24	83178	3/8-16 Jamb Nut	1
25	22662	Feed Door Hinge Bracket	1
26	89308	Feed Door Handle Assembly	1
**	891097	Feed Door Handle Assembly	1
27**	89574	Spring Handle	1
28	89319	Blower Gasket	2
29	80230	Blower Assembly	2
30**	80314	Thermodisc 60T12	1
N/S	80145	Limit Control	1
31	68234	Blower Thermostat Bracket	1
32	22761	Flue Collar Ring	1
33	22762	Forced Draft Ring	1
34	22140	Relay Box Bracket	1
35	80131	Junction Box (4 x 4)	1
36	80231	Junction Box Cover	1
37	89066	Firebrick (4-1/2W x 9L x 1-1/4H)	12
38	68228	Ash Pan Weldment	1
N/S	68231	Fan Control Cord Assembly	3

PARTS LIST - 1500/1537G

\*\* = PARTS USED ON 1537G ONLY - CABINET PARTS ARE GREEN IN COLOR  
 N/S = NOT SHOWN



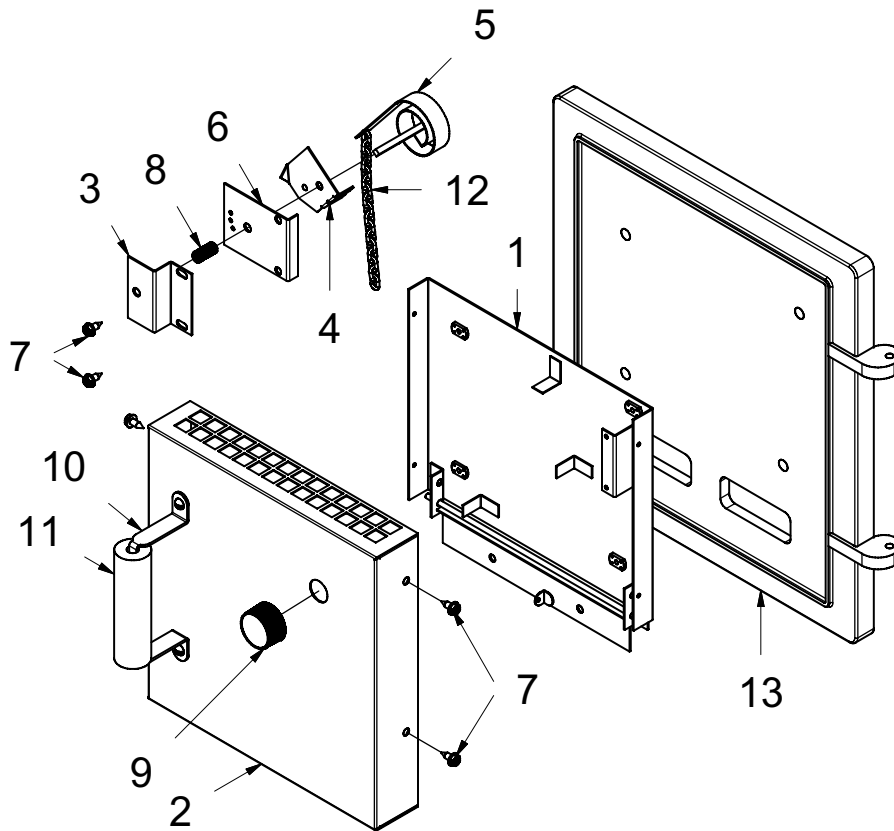

Thermostat Box Assembly	KEY	PART #	DESCRIPTION	QTY.
	-	68733	Thermostat Box Assembly (Color - Red)	-
	**	68733G	Thermostat Box Assembly (Color - Green)	-
	1	68722	Thermostat Panel Weldment	1
	2	68732	Thermostat Cover Weldment (Color - Red)	1
	**	68732G	Thermostat Cover Weldment (Color - Green)	1
	3	23429	Thermostat Step Plate	1
	4	23431	Friction Plate	1
	5	81903	Thermostat	1
	6	23427	Thermostat Mounting Bracket	1
	7	83172	#10 Sheet Metal Screw	6
	8	89041	Spring	1
9	89175	Thermostat Knob	1	
10	23425	Handle Bracket	2	
11	89520	Wooden Handle	1	
12	86318	Thermostat Chain	.542 FT	
13	68217	Feed Door Assembly (Includes Door and Gasket)	1	
N/S	83106S	Machine Screw, 10-24 x 1/2" SL HD Z	2	
N/S	83136	Washer, 9/32" I.D. - 5/8" O.D. - 1/16" THK.	1	
N/S	83816	Cotter Pin, 1/16" x 3/4"	1	

\*\* = PARTS USED ON 1537G - PARTS ARE GREEN IN COLOR  
 N/S = NOT SHOWN

## Central Installation

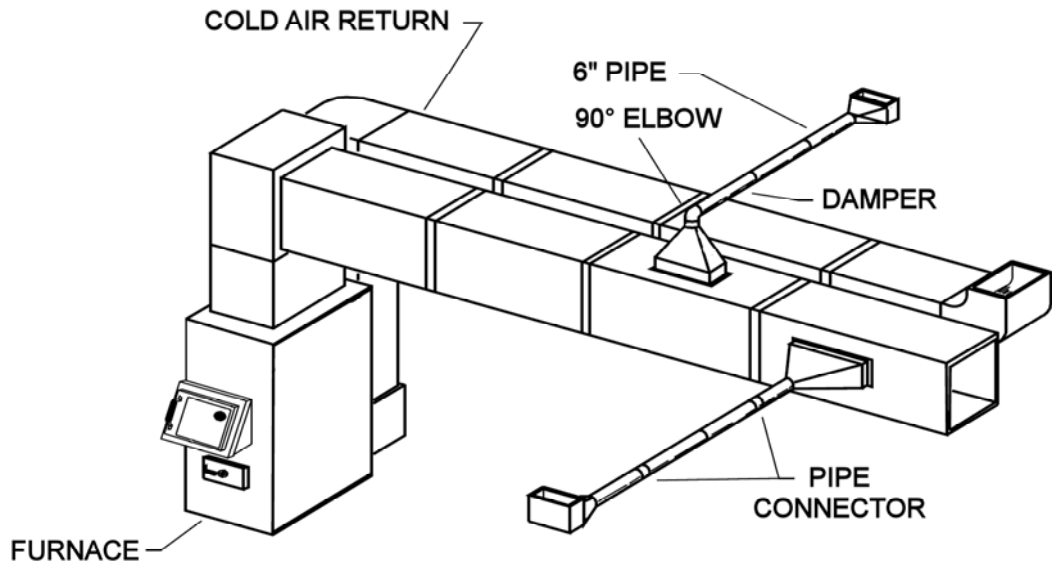

Fig. 15.1

## Add-On Installation

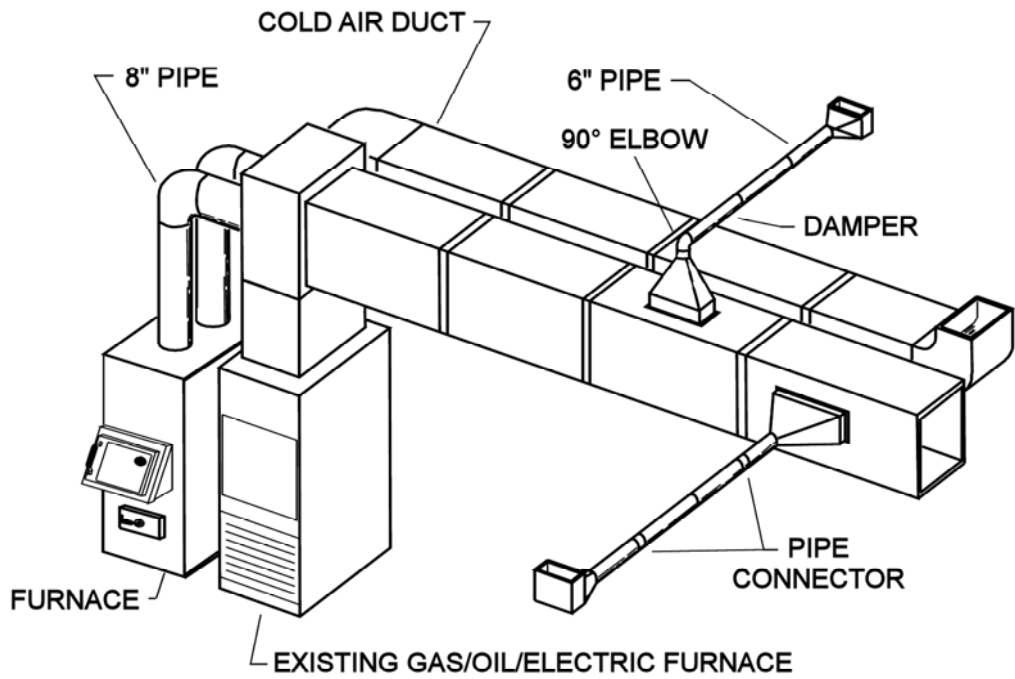
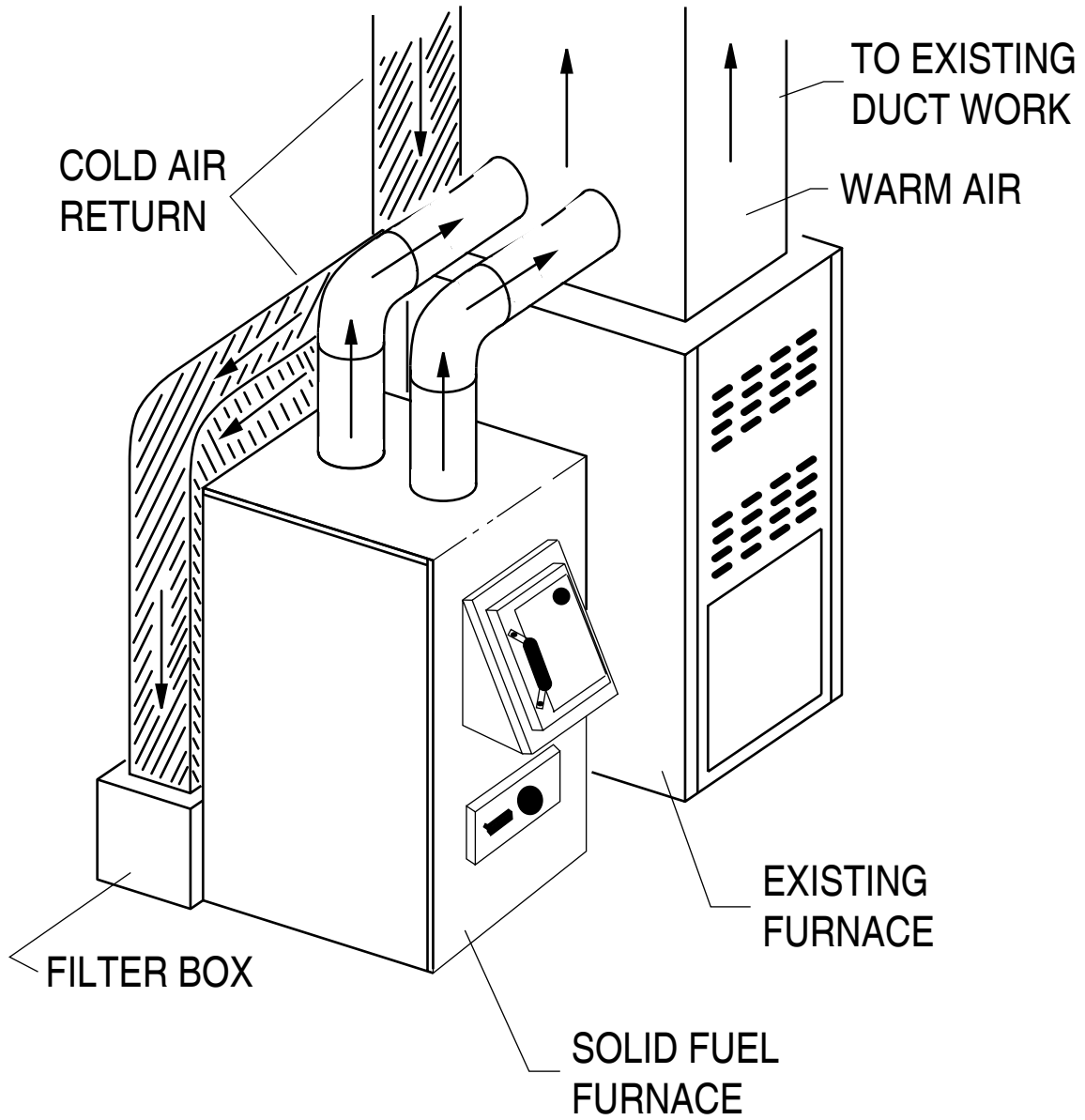

Fig. 15

# APPENDIX

## INSTALLATION A



## INSTALLATION B

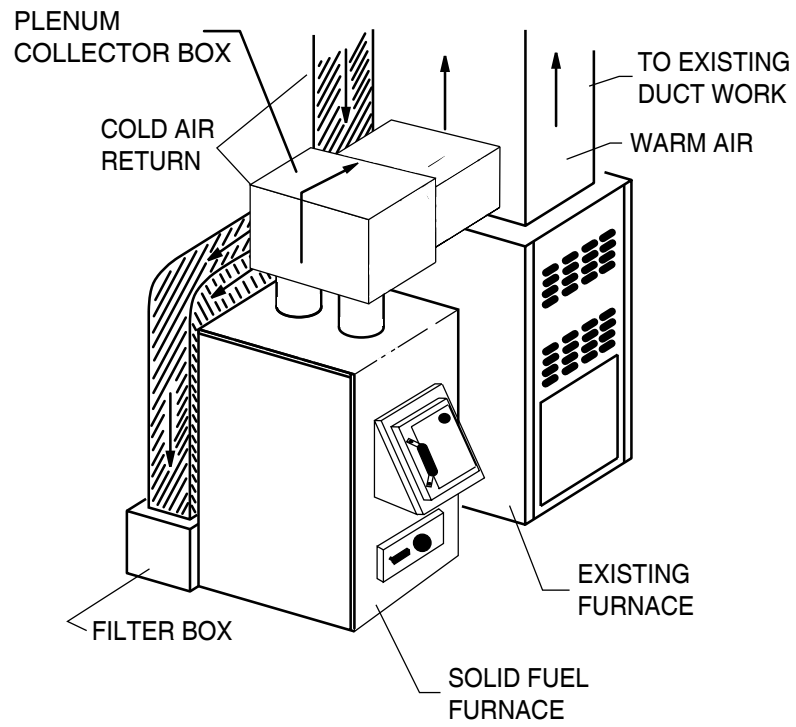

## INSTALLATION C

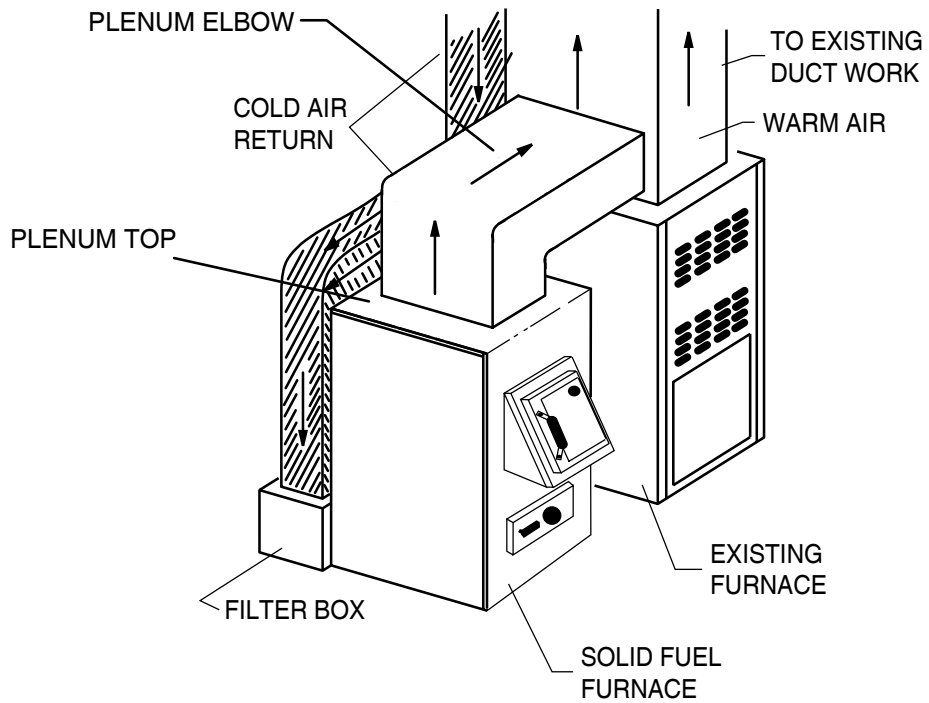

# INSTALLATION D

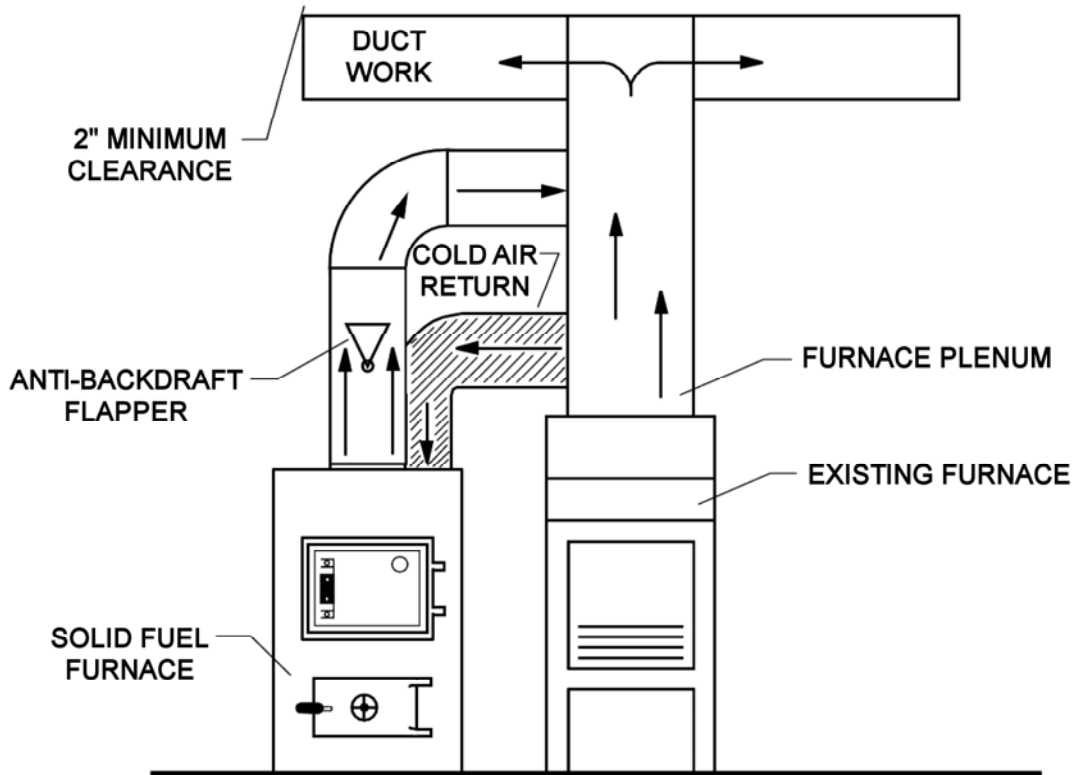

# INSTALLATION E

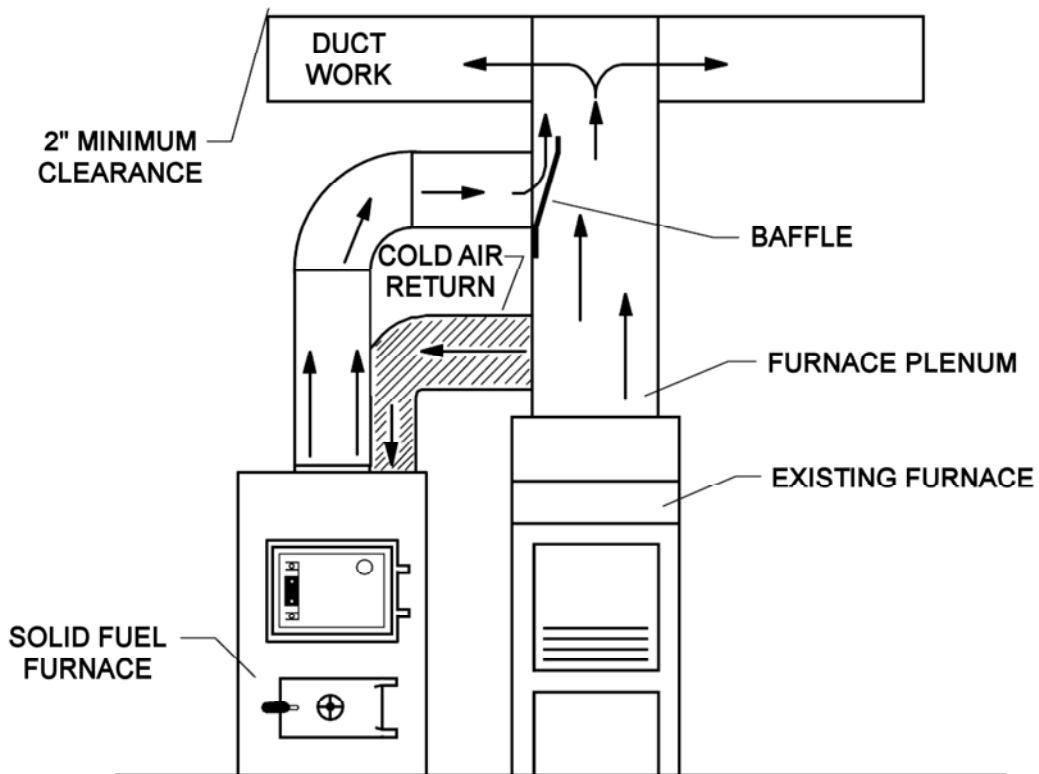

# INSTALLATION F

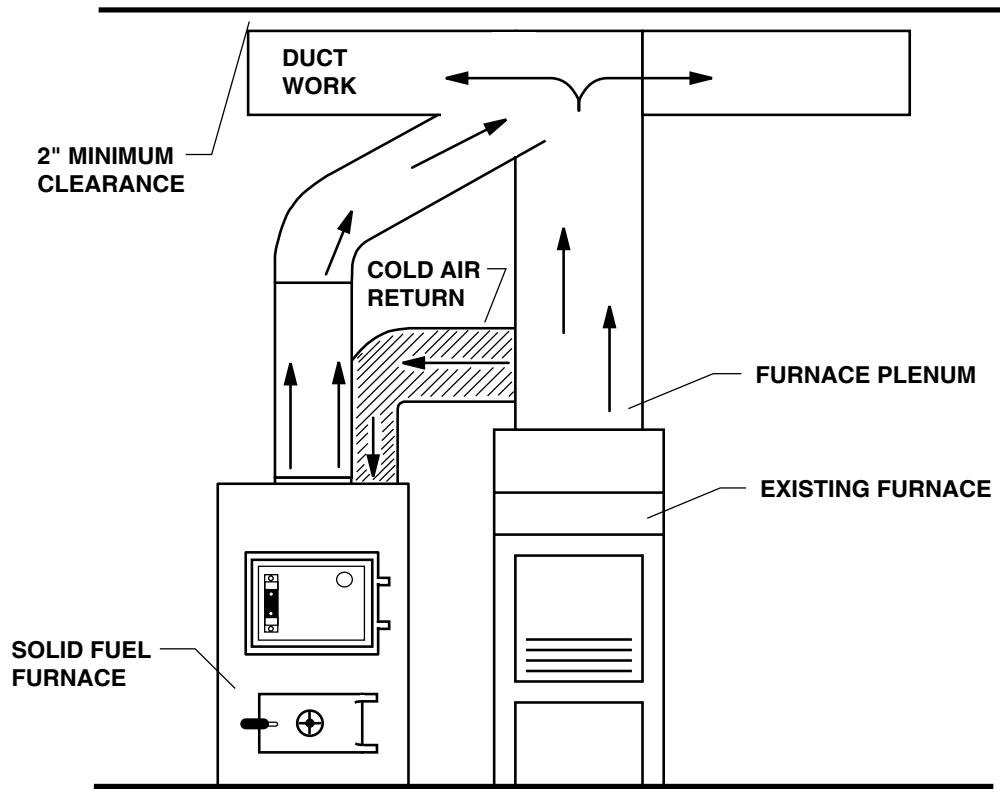

# INSTALLATION G

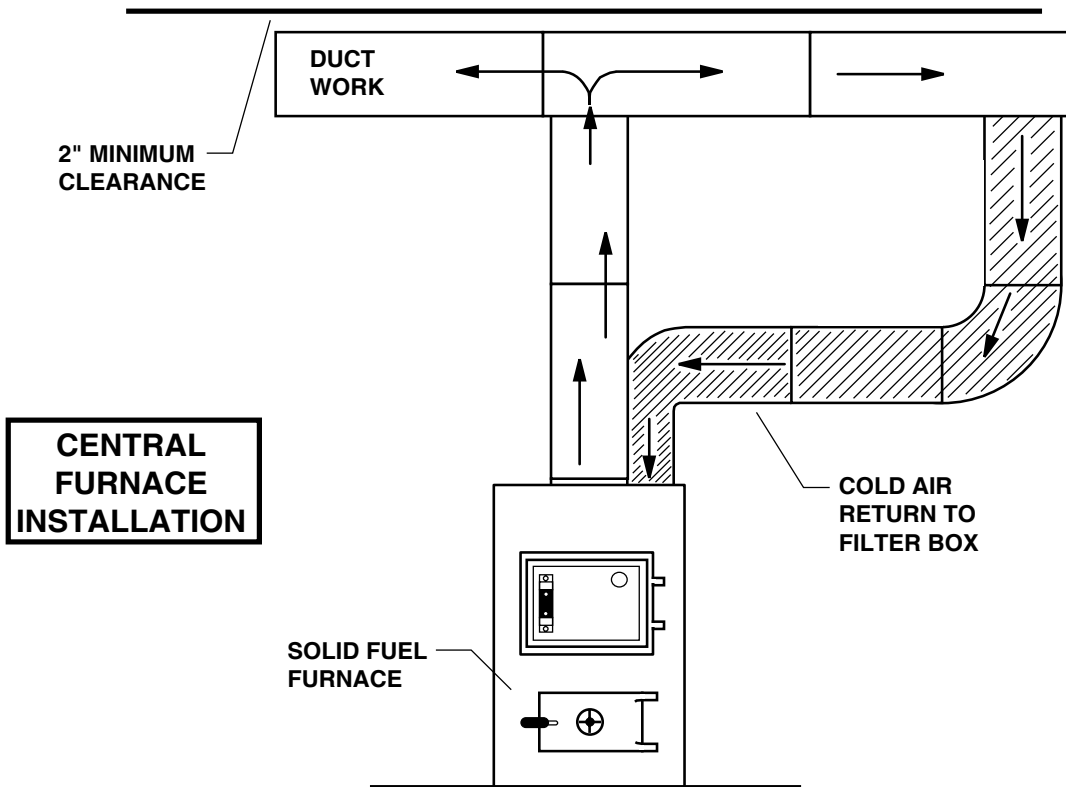

# INSTALLATION H

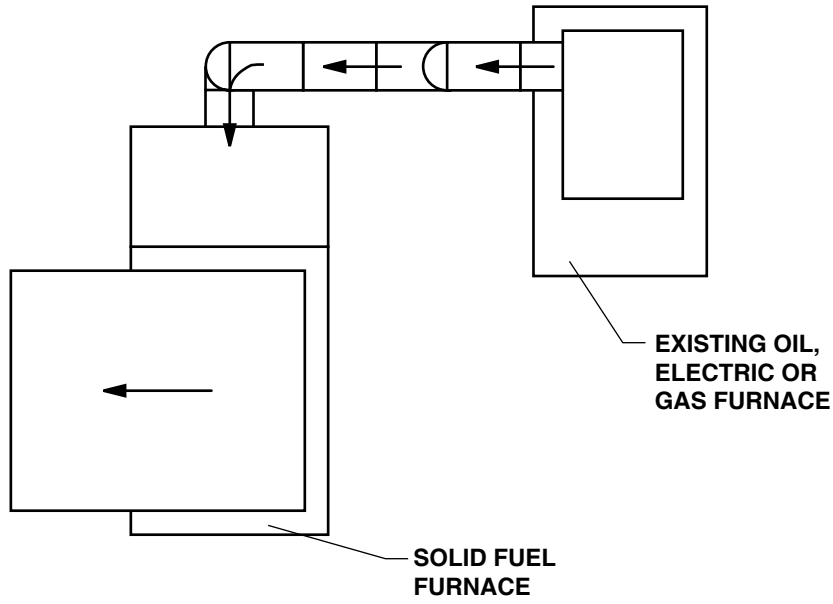

(TOP VIEW)

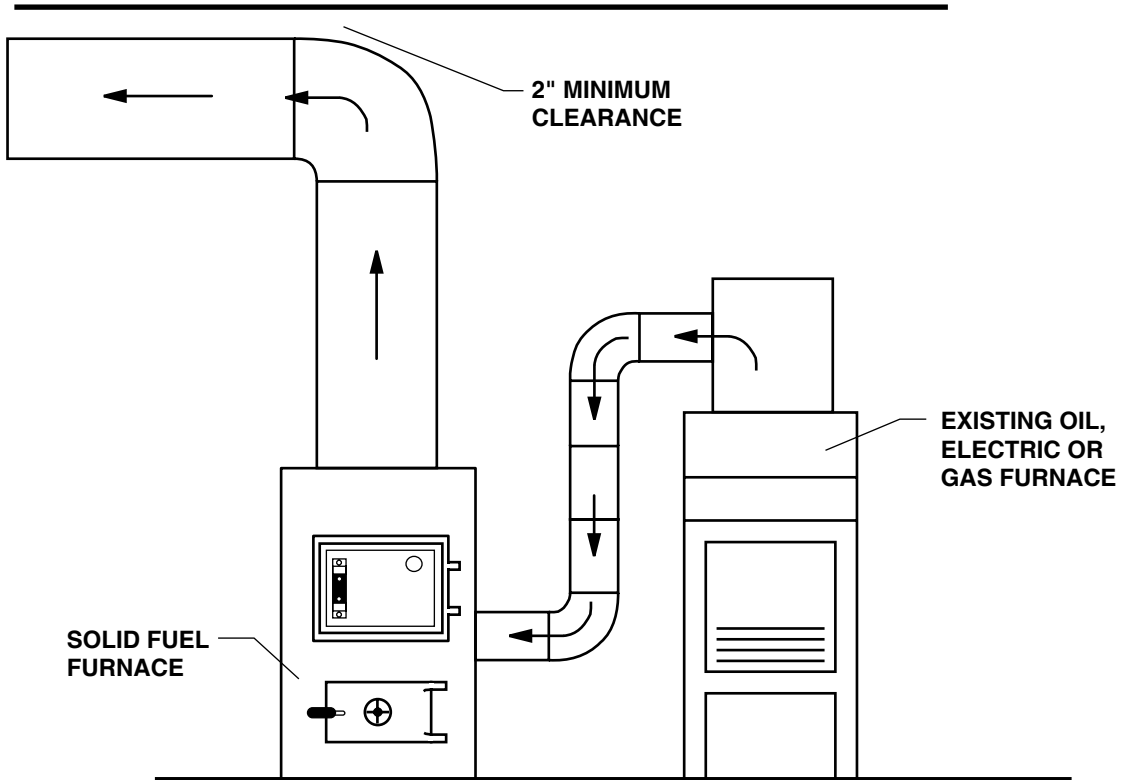

(FRONT VIEW)

## Trouble Shooting Tips for Warm Air Furnace

LIST OF PROBLEMS	POSSIBLE CAUSE	SOLUTIONS
1. Smoking when feed door is open.	<ul style="list-style-type: none"> <li>a) Insufficient Draft.</li> <li>b) Clogged chimney or chimney connector.</li> <li>c) Down draft in chimney.</li> </ul>	<ul style="list-style-type: none"> <li>a) Set Thermostat higher.</li> <li>b) Clean Chimney.</li> <li>c) Add raincap to chimney.</li> </ul>
2. Furnace does not heat.	<ul style="list-style-type: none"> <li>a) Wood not seasoned and dry.</li> <li>b) Insufficient flue draft.</li> </ul>	<ul style="list-style-type: none"> <li>a) Allow wood to season in a dry area for six months.</li> <li>b) Set flue draft.</li> </ul>
3. Blower Does not run.	<ul style="list-style-type: none"> <li>a) Improperly wired.</li> <li>b) Bad blower thermodisc.</li> <li>c) Bad relay.</li> <li>d) Bad blower motor</li> </ul>	<ul style="list-style-type: none"> <li>a) Wire unit properly.</li> <li>b) Replace blower thermodisc.</li> <li>c) Replace relay.</li> <li>d) Replace blower.</li> </ul>
4. No air from registers- fan running.	<ul style="list-style-type: none"> <li>a) Registers are closed.</li> <li>b) Duct work improperly installed.</li> <li>c) Improper wiring between central furnace and this unit.</li> </ul>	<ul style="list-style-type: none"> <li>a) Open registers.</li> <li>b) Correct duct work install.</li> <li>c) Wire unit properly.</li> </ul>
5. Air from Registers is not hot	Bad blower Thermodisc.	Replace blower Thermodisc.
6. Smoke and/or odor from registers when furnace is used for first time.	Oil from furnace and duct work.	The metal used in construction of the furnace and duct work has a light coating of oil. This should disappear after a short period of time. Once this burnoff has occurred, it should not reoccur.
7. Creosote build-up.	<ul style="list-style-type: none"> <li>a) Burning green wood (not seasoned or dry).</li> <li>b) Thermostat setting too low for type fuel.</li> </ul>	<ul style="list-style-type: none"> <li>a) Burn only seasoned wood.</li> <li>b) Set thermostat higher to attain higher flue temperatures. This will aid in preventing buildup of creosote.</li> </ul>
8. Flame spillage when feed door is open.	<ul style="list-style-type: none"> <li>a) Insufficient draft.</li> <li>b) Smothering fire when adding fresh fuel.</li> </ul>	<ul style="list-style-type: none"> <li>a) Set thermostat higher.</li> <li>b) Add fuel so as not to smother fire.</li> </ul>